



Designation: D7153 – 15<sup>ε1</sup>

IP 529/15

# Standard Test Method for Freezing Point of Aviation Fuels (Automatic Laser Method)<sup>1</sup>

This standard is issued under the fixed designation D7153; the number immediately following the designation indicates the year of original adoption or, in the case of revision, the year of last revision. A number in parentheses indicates the year of last reapproval. A superscript epsilon ( $\epsilon$ ) indicates an editorial change since the last revision or reapproval.

<sup>ε1</sup> NOTE—Figures 3, A1.3, and A1.5 were corrected editorially in March 2016.

## 1. Scope\*

1.1 This test method covers the determination of the temperature below which solid hydrocarbon crystals may form in aviation turbine fuels.

1.2 This test method is designed to cover the temperature range of  $-80\text{ }^{\circ}\text{C}$  to  $20\text{ }^{\circ}\text{C}$ ; however, the interlaboratory study mentioned in 12.4 has only demonstrated the test method with fuels having freezing points in the range of  $-60\text{ }^{\circ}\text{C}$  to  $-42\text{ }^{\circ}\text{C}$ .

1.3 The values stated in SI units are to be regarded as standard. No other units of measurement are included in this standard.

1.4 *This standard does not purport to address all of the safety concerns, if any, associated with its use. It is the responsibility of the user of this standard to establish appropriate safety and health practices and to determine the applicability of regulatory limitations prior to use.*

## 2. Referenced Documents

### 2.1 ASTM Standards:<sup>2</sup>

- D2386 Test Method for Freezing Point of Aviation Fuels
- D4057 Practice for Manual Sampling of Petroleum and Petroleum Products
- D4177 Practice for Automatic Sampling of Petroleum and Petroleum Products

### 2.2 Energy Institute Standard:

- IP 16 Determination Freezing Point of Aviation Fuels<sup>3</sup>

## 3. Terminology

### 3.1 Definitions:

<sup>1</sup> This test method is under the jurisdiction of ASTM Committee D02 on Petroleum Products, Liquid Fuels, and Lubricants and is the direct responsibility of Subcommittee D02.07 on Flow Properties.

Current edition approved April 1, 2015. Published April 2015. Originally approved in 2005. Last previous edition approved in 2010 as D7153 – 05 (2010). DOI: 10.1520/D7153-15E01.

<sup>2</sup> For referenced ASTM standards, visit the ASTM website, www.astm.org, or contact ASTM Customer Service at service@astm.org. For *Annual Book of ASTM Standards* volume information, refer to the standard's Document Summary page on the ASTM website.

<sup>3</sup> *Annual Book of IP Standards Methods*, Vol 1. Available from Energy Institute, 61 New Cavendish St., London, WIG 7AR, U.K.

3.1.1 *freezing point, n—in aviation fuels*, the fuel temperature at which solid hydrocarbon crystals, formed on cooling, disappear when the temperature of the fuel is allowed to rise under specified conditions of test.

### 3.2 Definitions of Terms Specific to This Standard:

3.2.1 *automatic laser method, n*—the procedures of automatically cooling a liquid aviation fuel specimen until solid hydrocarbon crystals appear, followed by controlled warming and recording of temperature at which hydrocarbon crystals completely redissolve into the liquid phase.

### 3.3 Symbols:

- $C_d$  = the specimen temperature at which the appearance of the first crystals are detected in the specimen by an optical crystal detector under specified conditions of test.
- $C_o$  = the specimen temperature at which the appearance of opacity in the specimen is detected by an optical opacity detector under specified conditions of test.
- $D_o$  = the specimen temperature at which the disappearance of opacity in the specimen is detected by an optical opacity detector under specified conditions of test.

## 4. Summary of Test Method

4.1 A specimen is cooled at a rate of  $10\text{ }^{\circ}\text{C}/\text{min} \pm 5\text{ }^{\circ}\text{C}/\text{min}$  while continuously being illuminated by a laser light source. The specimen is continuously monitored by optical crystal and opacity detectors for the first formation of solid hydrocarbon crystals. Once the hydrocarbon crystals are detected by both sets of optical detectors, the specimen is then warmed at a rate of  $3\text{ }^{\circ}\text{C}/\text{min} \pm 0.5\text{ }^{\circ}\text{C}/\text{min}$ . When initial opacity in the specimen disappears, the specimen is then warmed at a rate of  $12\text{ }^{\circ}\text{C}/\text{min} \pm 1\text{ }^{\circ}\text{C}/\text{min}$ . The specimen temperature at which the last hydrocarbon crystals return to the liquid phase, as detected by the crystal detector, is recorded as the freezing point.

4.2 In certain circumstances, as measured by the apparatus, the specimen is reheated to approximately  $10\text{ }^{\circ}\text{C}$ , then cooled at the rate in 4.1 until hydrocarbon crystals are detected by the crystal detector. The specimen is then warmed at a rate of

\*A Summary of Changes section appears at the end of this standard

12 °C/min  $\pm$  1 °C/min, until the last hydrocarbon crystals return to the liquid phase. The specimen temperature at which the last hydrocarbon crystals return to the liquid phase, as detected by the crystal detector, is recorded as the freezing point.

## 5. Significance and Use

5.1 The freezing point of an aviation fuel is the lowest temperature at which the fuel remains free of solid hydrocarbon crystals which, if present in the fuel system of the aircraft, can restrict the flow of fuel through filters. The temperature of the fuel in the aircraft tank normally decreases during flight depending on aircraft speed, altitude, and flight duration. The freezing point of the fuel shall always be lower than the minimum operational fuel temperature.

5.2 Petroleum blending operations require precise measurement of the freezing point.

5.3 This test method expresses results to the nearest 0.1 °C, and it eliminates most of the operator time and judgment required by Test Method [D2386](#).

5.4 When a specification requires Test Method [D2386](#), do not substitute this test method or any other test method.

## 6. Apparatus

6.1 *Automatic Apparatus*<sup>4</sup>—This apparatus consists of a microprocessor-controlled test cell that is capable of cooling and heating the specimen, dual optical detectors to monitor the appearance and disappearance of crystals and opacity, and recording the temperature of the specimen. A detailed description of the apparatus is provided in [Annex A1](#).

6.2 The apparatus shall be equipped with a specimen chamber, optical detectors, laser light source, digital display, cooling and heating systems, and a specimen temperature measuring device.

6.3 The temperature measuring device in the specimen chamber shall be capable of measuring the temperature of the specimen from  $-80$  °C to  $+20$  °C at a resolution of 0.1 °C and accuracy of 0.1 °C.

6.4 The apparatus shall be capable of cooling the specimen at a rate of 10 °C/min  $\pm$  5 °C/min, heating the specimen at rates of 3 °C/min  $\pm$  0.5 °C/min and 12 °C/min  $\pm$  1 °C/min over the temperature range of  $-80$  °C to  $+20$  °C.

NOTE 1—The apparatus described is covered by a patent. If you are aware of an alternative(s) to the patented item, please attach to your ballot return a description of the alternatives. All suggestions will be considered by the committee.

NOTE 2—The software version used in this apparatus is version V 5.3.

6.5 *Standard Syringe*, capable of injecting approximately 10 mL  $\pm$  2 mL of the specimen, with a tip or an adapter tip that

will fit the inlet of the test cell. A disposable 10 mL syringe with a Luer type cone connection has been found suitable.

6.6 *Waste Receiving Container*, capable of collecting the overflow when the specimen is injected into the test cell. A 400 mL standard glass beaker has been found suitable.

## 7. Sampling

7.1 Obtain a sample in accordance with Practice [D4057](#) or [D4177](#).

7.2 At least 30 mL of sample is required for each test.

## 8. Preparation of Apparatus

8.1 Install the apparatus for operation in accordance with the manufacturer's instructions.

8.2 Turn on the main power switch of the analyzer.

## 9. Calibration and Standardization

9.1 Ensure that all of the manufacturer's instructions for calibration of the mechanical and electronic systems and operation of the apparatus are followed.

9.2 To verify the performance of the apparatus, an aviation turbine fuel sample for which extensive data has been obtained by Test Method [D2386](#) may be used. Samples such as those used in the ASTM interlaboratory cross-check program would meet this criterion. Such verification materials can also be prepared from intra-company cross-checks.

9.3 At intervals of not more than 12 months, check the temperature measuring system against a temperature measuring device that has a current calibration certificate.

9.4 Verify the correct functioning of the apparatus in accordance with the manufacturer's instructions using a verification liquid (9.2) when first installed and thereafter at intervals not exceeding one month.

## 10. Procedure

10.1 Draw 10 mL  $\pm$  2 mL bubble-free portion of sample into a syringe. Connect the syringe to the inlet port ([Fig. 1](#)). Rinse the test cell by injecting 10 mL  $\pm$  2 mL of specimen into the test cell; the specimen excess will flow into the waste receiving container ([Fig. 2](#))

10.2 Rinse the test cell a second time by repeating [10.1](#).

10.3 Draw a 10 mL  $\pm$  2 mL bubble-free portion of sample into a syringe.

10.4 Connect the syringe to the inlet port ([Fig. 1](#)). Dispense the specimen into the test cell; the specimen excess will flow into the waste receiving container ([Fig. 2](#)). Leave the syringe connected to the sample inlet for the entire duration of the test.

10.5 Start the operation of the apparatus according the manufacturer's instructions. From this point through Section [11](#), the apparatus automatically controls the procedure.

10.5.1 Cool the specimen at a rate of 10 °C/min  $\pm$  5 °C/min while continuously illuminating with a polarized laser light source. Monitor the specimen continuously with two optical detectors, an opacity detector and a crystal detector ([Fig. 3](#)), for the first formation of solid hydrocarbon crystals.

<sup>4</sup> The sole source of supply of the apparatus known to the committee at this time is ISL model FZP 5G2s series Freezing Point Analyzer, available from PAC - ISL, BP 70285 - VERSON, 14653 CARPIQUET Cedex, France. If you are aware of alternative suppliers, please provide this information to ASTM International Headquarters. Your comments will receive careful consideration at a meeting of the responsible technical committee,<sup>1</sup> which you may attend.

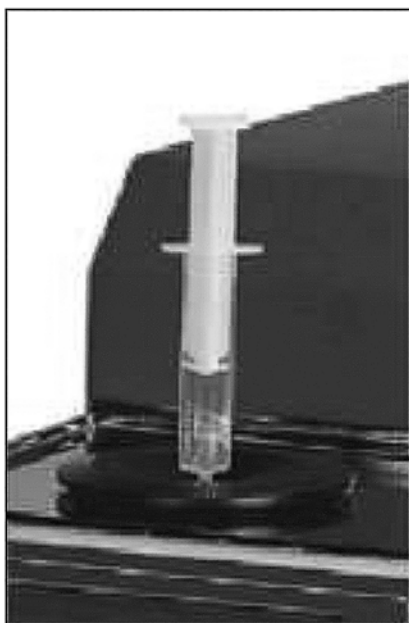

FIG. 1 Syringe Inserted in Inlet Port



FIG. 2 Waste Container

10.5.2 Once the appearance of the first crystals (*Cd*) is detected on the crystal detector and opacity (*Co*) is detected on the opacity detector, warm the specimen at a rate of 3 °C/min ± 0.5 °C/min until the disappearance of the opacity (*Do*) is detected on the opacity detector. At that point, warm the specimen at a rate of 12 °C/min ± 1 °C/min while it is still monitored by the crystal detector. When the disappearance of the last crystals is detected on the crystal detector, record the specimen temperature at which the last hydrocarbon crystals return to the liquid phase. Refer to A1.2.12 and Fig. A1.5 for detection curve examples.

10.5.3 Compare this recorded temperature with the temperature at which the first crystals were detected (*Cd*). When the recorded temperature is warmer than the (*Cd*) temperature, it is recorded as the freezing point.

NOTE 3—In most cases, 10.5.3 is considered the termination of the test. (See 10.5.4.)

10.5.4 In certain circumstances, as measured by the apparatus, perform a second test cycle as follows in 10.6.

NOTE 4—This circumstance may indicate the presence of contamination of the specimen with material other than aviation fuel and the stated precisions may not apply.

#### 10.6 Second Test Cycle:

10.6.1 The original specimen is warmed up to approximately 10 °C and then cooled at a rate of 10 °C/min ± 5 °C/min while continuously being illuminated by a polarized laser light source. Monitor the specimen continuously with the optical crystal detector (Fig. 3) for the first formation of solid hydrocarbon crystals.

10.6.2 Once the appearance of the first crystals (*Cd*) are detected on the crystal detector, continue to cool the specimen an additional 5 °C and then discontinue the cooling.

10.6.3 Warm the specimen a rate of 12 °C/min ± 1 °C/min while it is still monitored by the crystal detector. When the disappearance of the last crystals is detected on the crystal detector, record the specimen temperature at which the last hydrocarbon crystals return to the liquid phase as the freezing point.

NOTE 5—When condition described in 10.5.4 is encountered, this indicates that the sample may be contaminated. In that case, in order to minimize the test duration, only the 12 °C ± 1 °C warming rate is used.

10.7 Once the freezing point is recorded, the test cell is warmed up to ambient temperature. Fig. A1.5 gives two examples of the testing process: one with a neat jet fuel, and one with a contaminated jet fuel.

10.8 The freezing point value will be automatically rounded to the nearest 0.1 °C and displayed by the apparatus.

10.9 Disconnect the injection syringe from the sample inlet. The cleaning of the test cell will be carried out during the performance of the next test.

## 11. Report

11.1 Report the temperature recorded in 10.8 as the freezing point, determined by Test Method D7153.

## 12. Precision and Bias

12.1 *Precision*—The precision of this test method as determined by the statistical examination of the interlaboratory<sup>5</sup> test results is as follows:

12.1.1 *Repeatability*—The difference between two test results obtained by the same operator with the same apparatus under constant operating conditions on identical test material would, in the long run, in the normal and correct operation of this test method, exceed 0.6 °C only in one case in twenty.

<sup>5</sup> Supporting data (the results of the 2003 Interlaboratory Cooperative Test Program) have been filed at ASTM International Headquarters and may be obtained by requesting Research Report RR:D02-1572.

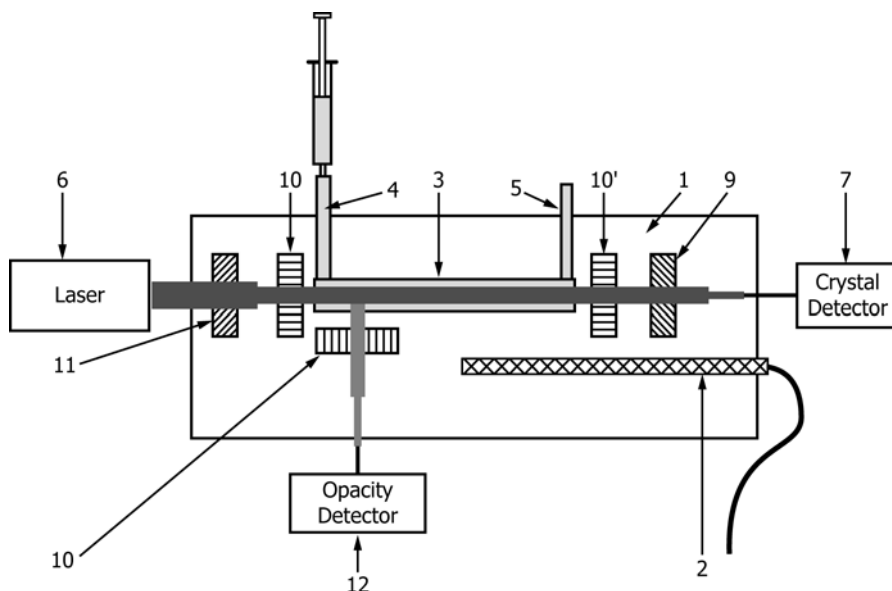

where:

- 1 = Specimen chamber
- 2 = Temperature probe
- 3 = Specimen test cell
- 4 & 5 = Specimen inlet and outlet
- 6 = Laser
- 7 = Crystal detector (see solid line curve in Fig. A1.5)
- 9 & 11 = Polarization filters
- 10 = Windows
- 12 = Opacity detector (see dotted line curve in Fig. A1.5)

FIG. 3 Principle of Detection

12.1.2 *Reproducibility*—The difference between two single and independent results obtained by different operators working in different laboratories on identical test material would, in the long run, in the normal and correct operation of this test method, exceed 0.9 °C only in one case in twenty.

12.2 *Bias*—Because there are no liquid hydrocarbon mixtures of known freezing point, which simulate aviation fuels, bias cannot be established.

12.3 *Relative Bias*—The results for all the samples from the interlaboratory program<sup>5</sup> were examined for biases relative to Test Method D2386 and IP 16. A systemic bias was observed and is quantified with the following equation:

$$D2386 \text{ and IP } 16 = X - 0.347 \quad (1)$$

where:

- D2386 and IP 16 = mean of the result tested by D2386 and IP 16.
- X = mean of the result tested by this test method (D7153).

12.3.1 As example: For a D2386 and IP 16 result of -60 °C, the result from this test method is -59.65 °C, or 0.347 °C warmer than the D2386 and IP 16 result.

12.3.2 However, the relative bias is within the reproducibility of both test methods.

12.3.3 The cross method reproducibility (Rxy), identified in the research report,<sup>5</sup> between this test method and Test Method D2386 is 1.9. (See research report<sup>5</sup> for further information on relative bias and the methods used to derive them.)

12.4 The precision statements were derived from a 2003 interlaboratory cooperative test program.<sup>5</sup> Participants analyzed 13 samples sets comprised of various aviation fuels over the temperature range of -42 °C to -60 °C. Thirteen laboratories participated with the automatic laser method and fifteen with the manual D2386 or IP 16 test methods. The precision statistics were compiled and calculated based on the 0.1 °C resolution offered by the automatic laser method. Information on the types of samples and their respective average freezing point is contained in the research report available at ASTM Headquarters.<sup>5</sup>

### 13. Keywords

13.1 aviation turbine fuels; freezing point; wax crystals



**ANNEX**
**(Mandatory Information)**
**A1. APPARATUS DETAILS**

A1.1 *General*—The microprocessor controlled test apparatus is described in A1.2 and illustrated in Fig. A1.1.

A1.2 Test apparatus shall consist of sample inlet tubing, optical detectors, laser light source, specimen chamber, temperature sensor, cooling system, and heater system arranged in a configuration as shown in Fig. A1.1.

A1.2.1 *Test Cell*, comprised of sample inlet tubing, optical detectors, laser light source, specimen chamber, temperature sensor, cooling device, and heater arranged in a configuration as shown in Fig. A1.2.

A1.2.2 *Specimen Chamber*, comprised of an aluminum block bored with a hole of  $3.7 \text{ mm} \pm 0.1 \text{ mm}$  on a length of  $22 \text{ mm} \pm 2 \text{ mm}$ . The minimum external dimensions of the aluminum block will be 66 mm by 42 mm by 16 mm. See Fig. A1.2.

A1.2.3 *Temperature Sensor*, capable of reading to  $0.1 \text{ }^\circ\text{C}$  over the range  $+20 \text{ }^\circ\text{C}$  to  $-80 \text{ }^\circ\text{C}$  with a maximum error of  $0.1 \text{ }^\circ\text{C}$ . The sensor shall be calibrated at intervals of not more than 12 months, and the calibration certificate shall include corrections of at least the temperatures of  $+20 \text{ }^\circ\text{C}$ ,  $-40 \text{ }^\circ\text{C}$ , and  $-80 \text{ }^\circ\text{C}$ . The sensor shall be permanently embedded into the bottom of the specimen chamber and located in a position to measure accurately the specimen temperature.

A1.2.4 *Cooling System*, an integral cooling system, capable of controlling the specimen temperature within the range of anticipated test temperatures with a  $0.1 \text{ }^\circ\text{C}$  accuracy.

A1.2.5 *Heating System*, coupled to the specimen chamber capable of controlling the specimen temperature within the range of anticipated test temperatures with a  $0.1 \text{ }^\circ\text{C}$  accuracy.

A1.2.6 *Optical Detection System*—An electronic optical system for monitoring the specimen for the appearance/disappearance of hydrocarbon crystals. The wavelength of the laser light source shall be  $650 \text{ nm} \pm 20 \text{ nm}$  with a 3 mW power. The system shall be composed of a light transmitter and two light receivers, the crystal detector and the opacity detector. Two filters to polarize the light shall be positioned at each extremity of 3.7 mm bore of the specimen chamber described in A1.2.2. The opacity receiver shall be located at  $6 \text{ mm} + 0.5 \text{ mm}$  from the extremity of the bore of the specimen chamber, on the emitter side with a  $90^\circ$  angle. The window of the opacity detector shall be tangent with the 3.7 mm bore.

NOTE A1.1—When the specimen is a homogeneous liquid, the crystal and the opacity detector do not receive any light. The signals received on the crystal detector and the opacity detector are transmitted to a microprocessor system and analyzed. When hydrocarbon crystals appear in the specimen, the light beam is scattered and signal are received on both detectors. A typical configuration is shown in Fig. A1.2.

A1.2.7 *Apparatus Exterior Interface*—The exact layout may vary; however, the following displays and push buttons are recommended. A typical apparatus (see Fig. A1.3) is shown as an example.

A1.2.8 *Display*, gives an update of the specimen temperature during the measurement and with different menus provides information on the status of the apparatus. It shall display an appropriate message when the apparatus is idle and no fault is found. At the end of a test, the result is displayed. It shall be possible to display the scattered light level received by the optical detectors. This information may be used by service personnel for troubleshooting purposes. It displays a diagnostic message if a fault is detected in any of the major components of the apparatus. Detailed explanation of the diagnostic messages is available in the manufacturer's service manual.

A1.2.9 *Menu Buttons*, allow the operator to access to the different menus like the change of the temperature from Celsius to Fahrenheit and vice versa; noting that the Celsius scale is regarded as the standard.

A1.2.10 *Run Button*, allows the operator to start the measurement sequence once the specimen is put inside the test.

A1.2.11 *Stop Button*, allows the operator to stop the measurement sequence. Upon pressing this button, the apparatus will immediately stop the measurement sequence and warm the specimen to ambient temperature.

A1.2.12 *Testing Process Charts*, only possible with an output device. An example of possible signal curves is shown on Fig. A1.5. The specimen temperature profile shown is not available for the operator, it is given in Fig. A1.5 for a better understanding of the specimen cooling profiles. Each fuel and each contamination will produce different detection curves. However, when the same type of sample is tested, the detection and opacity signals remain identical. This allows the operator to determine the fingerprint of the sample and detect any product modification by comparing the signal curves. The peaks observed on the curve named "Detection Signal" corresponds to the modification of the polarization of the light going through the test specimen. This polarization modification is created by the presence of crystals within the test specimen. The curves named "Neat Jet Fuel" give an example of a sample without contamination. The peaks observed on the detection signal curve show the appearance of the first crystal and the melting of the last crystal. Several peaks may be observed with a contaminated sample. This corresponds to the crystallization of the contaminant followed by the one of the jet fuel. In that particular case, during the warming phase, the melting of the jet fuel crystals and the melting of the contaminant crystals are observed at different temperatures. This demonstrates the presence of a contaminant.

NOTE A1.2—A full description, installation, setup instructions, and maintenance instructions are contained within the manufacturer's manual supplied with each instrument.

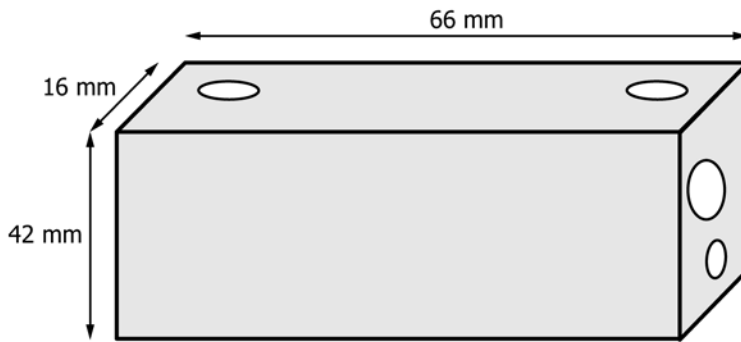
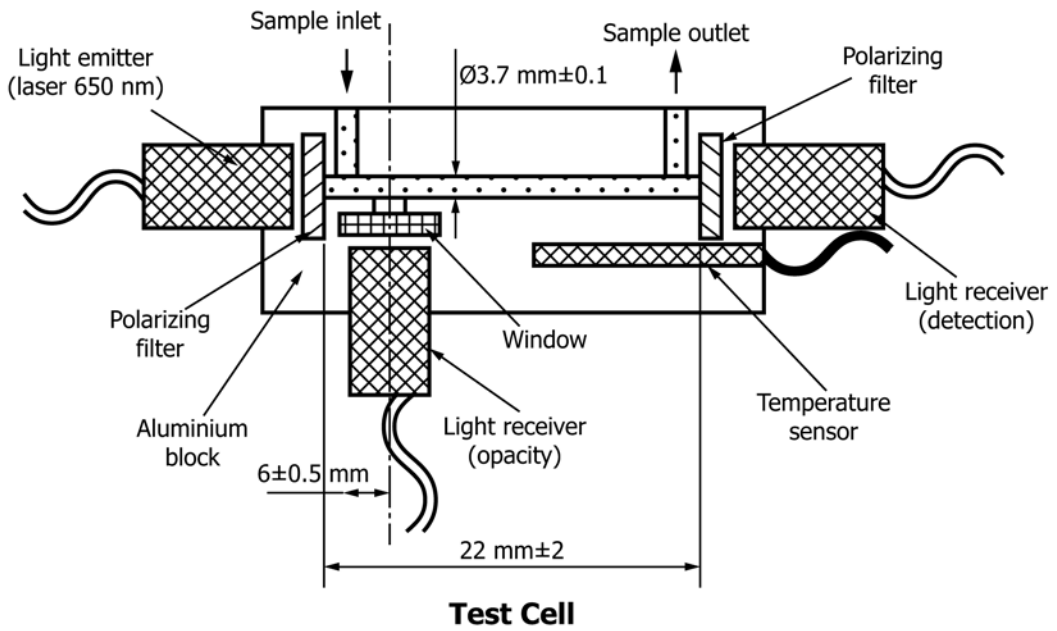

**Minimum dimensions of the aluminum block**

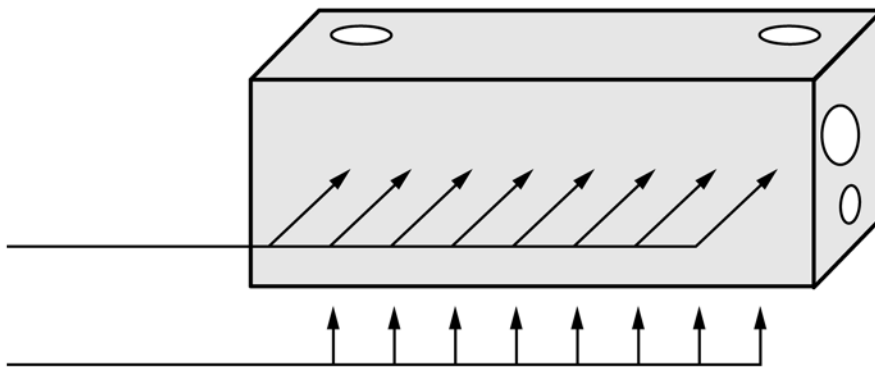

**Cooling and heating are applied on the sides of the cell**

FIG. A1.1 Test Cell

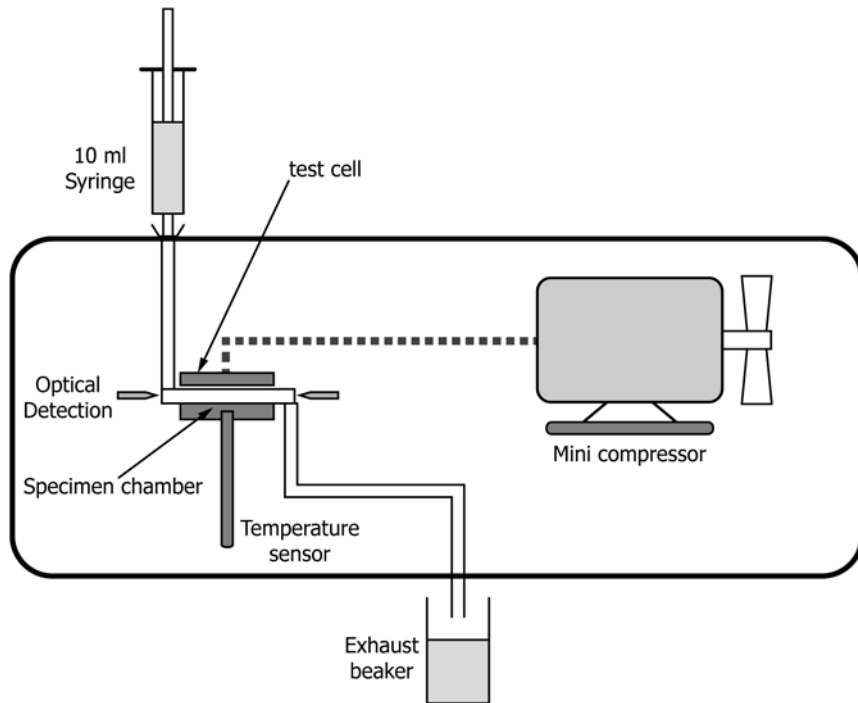

FIG. A1.2 Principle of the Apparatus

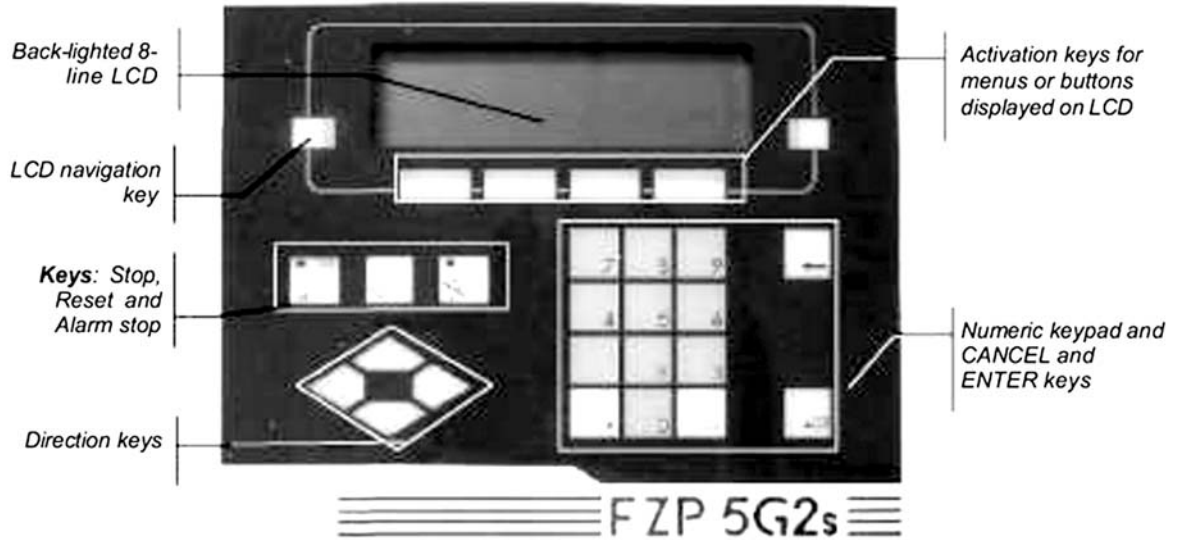

FIG. A1.3 Apparatus Exterior Interface



FIG. A1.4 Automatic Freezing Point Apparatus



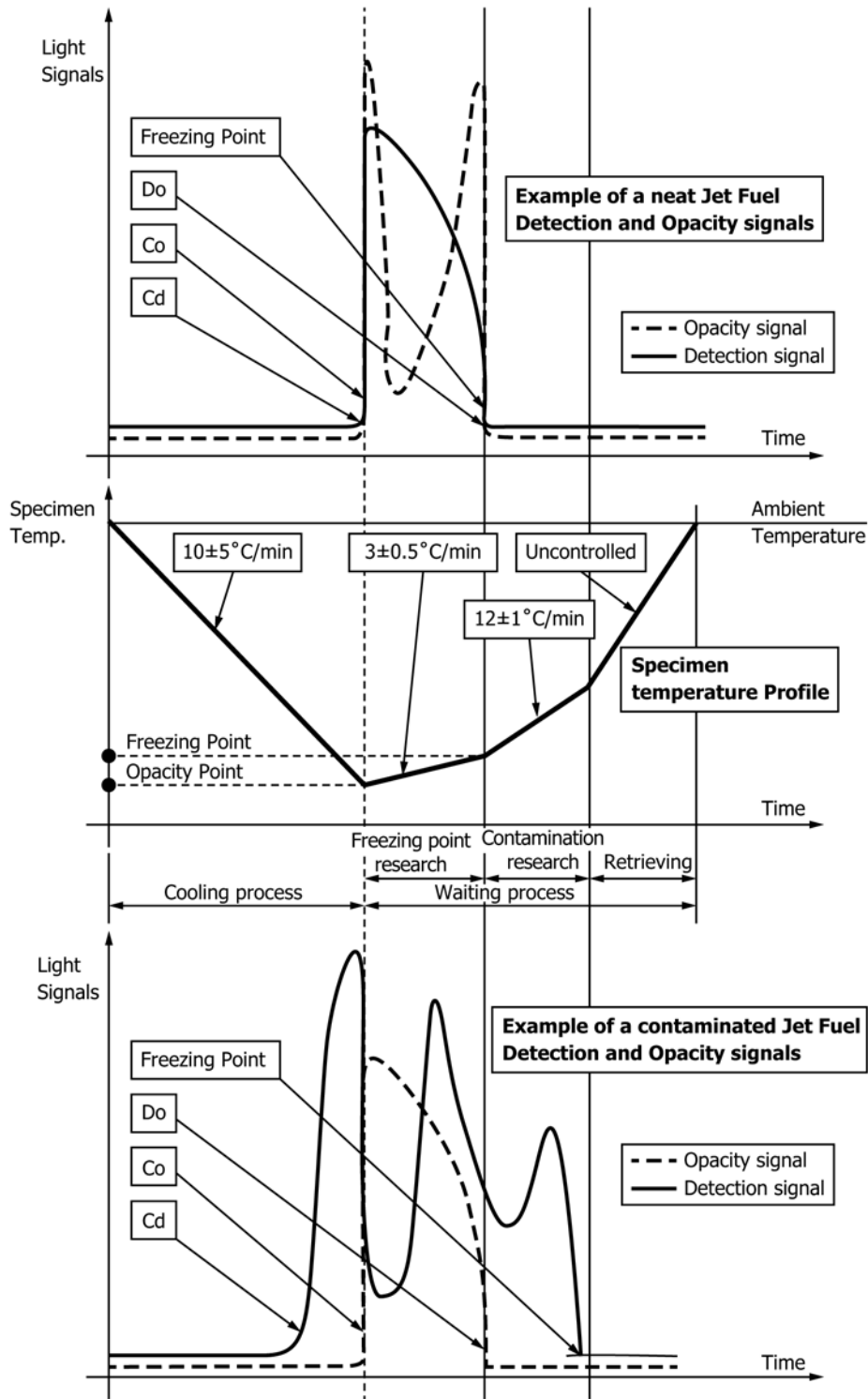

FIG. A1.5 Testing Process Chart

**SUMMARY OF CHANGES**

Subcommittee D02.07 has identified the location of selected changes to this standard since the last issue (D7153 – 05 (2010)) that may impact the use of this standard. (Approved April 1, 2015.)

(1) Updated IP designation.

(2) Added new subsections **9.3** and **9.4**.

*ASTM International takes no position respecting the validity of any patent rights asserted in connection with any item mentioned in this standard. Users of this standard are expressly advised that determination of the validity of any such patent rights, and the risk of infringement of such rights, are entirely their own responsibility.*

*This standard is subject to revision at any time by the responsible technical committee and must be reviewed every five years and if not revised, either reapproved or withdrawn. Your comments are invited either for revision of this standard or for additional standards and should be addressed to ASTM International Headquarters. Your comments will receive careful consideration at a meeting of the responsible technical committee, which you may attend. If you feel that your comments have not received a fair hearing you should make your views known to the ASTM Committee on Standards, at the address shown below.*

*This standard is copyrighted by ASTM International, 100 Barr Harbor Drive, PO Box C700, West Conshohocken, PA 19428-2959, United States. Individual reprints (single or multiple copies) of this standard may be obtained by contacting ASTM at the above address or at 610-832-9585 (phone), 610-832-9555 (fax), or [service@astm.org](mailto:service@astm.org) (e-mail); or through the ASTM website ([www.astm.org](http://www.astm.org)). Permission rights to photocopy the standard may also be secured from the Copyright Clearance Center, 222 Rosewood Drive, Danvers, MA 01923, Tel: (978) 646-2600; <http://www.copyright.com/>*