



# Standard Test Method for Compressive Residual Strength Properties of Damaged Polymer Matrix Composite Plates<sup>1</sup>

This standard is issued under the fixed designation D7137/D7137M; the number immediately following the designation indicates the year of original adoption or, in the case of revision, the year of last revision. A number in parentheses indicates the year of last reappraisal. A superscript epsilon ( $\epsilon$ ) indicates an editorial change since the last revision or reappraisal.

## 1. Scope

1.1 This test method covers compression residual strength properties of multidirectional polymer matrix composite laminated plates, which have been subjected to quasi-static indentation per Test Method [D6264/D6264M](#) or drop-weight impact per Test Method [D7136/D7136M](#) prior to application of compressive force. The composite material forms are limited to continuous-fiber reinforced polymer matrix composites with multidirectional fiber orientations, and which are both symmetric and balanced with respect to the test direction. The range of acceptable test laminates and thicknesses is defined in [8.2](#).

NOTE 1—When used to determine the residual strength of drop-weight impacted plates, this test method is commonly referred to as the Compression After Impact, or CAI, method.

1.2 The method utilizes a flat, rectangular composite plate, previously subjected to a damaging event, which is tested under compressive loading using a stabilization fixture.

NOTE 2—The damage tolerance properties obtained are particular to the type, geometry and location of damage inflicted upon the plate.

1.3 The properties generated by this test method are highly dependent upon several factors, which include specimen geometry, layup, damage type, damage size, damage location, and boundary conditions. Thus, results are generally not scalable to other configurations, and are particular to the combination of geometric and physical conditions tested.

1.4 This test method can be used to test undamaged polymer matrix composite plates, but historically such tests have demonstrated a relatively high incidence of undesirable failure modes (such as end crushing). Test Method [D6641/D6641M](#) is recommended for obtaining compressive properties of undamaged polymer matrix composites.

1.5 The values stated in either SI units or inch-pound units are to be regarded separately as standard. The values stated in each system may not be exact equivalents; therefore, each

system shall be used independently of the other. Combining values from the two systems may result in non-conformance with the standard.

1.5.1 Within the text the inch-pound units are shown in brackets.

1.6 *This standard does not purport to address all of the safety concerns, if any, associated with its use. It is the responsibility of the user of this standard to establish appropriate safety and health practices and determine the applicability of regulatory limitations prior to use.*

## 2. Referenced Documents

### 2.1 ASTM Standards:<sup>2</sup>

- [D792 Test Methods for Density and Specific Gravity \(Relative Density\) of Plastics by Displacement](#)
- [D883 Terminology Relating to Plastics](#)
- [D3171 Test Methods for Constituent Content of Composite Materials](#)
- [D3878 Terminology for Composite Materials](#)
- [D5229/D5229M Test Method for Moisture Absorption Properties and Equilibrium Conditioning of Polymer Matrix Composite Materials](#)
- [D5687/D5687M Guide for Preparation of Flat Composite Panels with Processing Guidelines for Specimen Preparation](#)
- [D6264/D6264M Test Method for Measuring the Damage Resistance of a Fiber-Reinforced Polymer-Matrix Composite to a Concentrated Quasi-Static Indentation Force](#)
- [D6641/D6641M Test Method for Compressive Properties of Polymer Matrix Composite Materials Using a Combined Loading Compression \(CLC\) Test Fixture](#)
- [D7136/D7136M Test Method for Measuring the Damage Resistance of a Fiber-Reinforced Polymer Matrix Composite to a Drop-Weight Impact Event](#)
- [E4 Practices for Force Verification of Testing Machines](#)
- [E6 Terminology Relating to Methods of Mechanical Testing](#)
- [E122 Practice for Calculating Sample Size to Estimate, With](#)

<sup>1</sup> This test method is under the jurisdiction of ASTM Committee [D30](#) on Composite Materials and is the direct responsibility of Subcommittee [D30.05](#) on Structural Test Methods.

Current edition approved April 1, 2012. Published May 2012. Originally approved in 2005. Last previous edition approved in 2007 as [D7137/D7137M-07](#). DOI: 10.1520/D7137\_D7137M-12.

<sup>2</sup> For referenced ASTM standards, visit the ASTM website, [www.astm.org](http://www.astm.org), or contact ASTM Customer Service at [service@astm.org](mailto:service@astm.org). For *Annual Book of ASTM Standards* volume information, refer to the standard's Document Summary page on the ASTM website.

Specified Precision, the Average for a Characteristic of a Lot or Process

**E177** Practice for Use of the Terms Precision and Bias in ASTM Test Methods

**E456** Terminology Relating to Quality and Statistics

**E1309** Guide for Identification of Fiber-Reinforced Polymer-Matrix Composite Materials in Databases

**E1434** Guide for Recording Mechanical Test Data of Fiber-Reinforced Composite Materials in Databases

2.2 *Military Standards:*

**NASA Reference Publication 1092** Standard Tests for Toughened Resin Composites, Revised Edition, July 1983<sup>3</sup>

### 3. Terminology

3.1 *Definitions*—Terminology **D3878** defines terms relating to composite materials. Terminology **D883** defines terms relating to plastics. Terminology **E6** defines terms relating to mechanical testing. Terminology **E456** and Practice **E177** define terms relating to statistics. In the event of a conflict between terms, Terminology **D3878** shall have precedence over the other standards.

3.2 *Definitions of Terms Specific to This Standard:*

3.2.1 If the term represents a physical quantity, its analytical dimensions are stated immediately following the term (or letter symbol) in fundamental dimension form, using the following ASTM standard symbology for fundamental dimensions, shown within square brackets:  $[M]$  for mass,  $[L]$  for length,  $[T]$  for time,  $[\theta]$  for thermodynamic temperature, and  $[nd]$  for non-dimensional quantities. Use of these symbols is restricted to analytical dimensions when used with square brackets, as the symbols may have other definitions when used without the brackets.

<sup>3</sup> Available from National Aeronautics and Space Administration (NASA)-Langley Research Center, Hampton, VA 23681-2199.

3.2.2 *nominal value, n*—a value, existing in name only, assigned to a measurable property for the purpose of convenient designation. Tolerances may be applied to a nominal value to define an acceptable range for the property.

3.2.3 *principal material coordinate system, n*—a coordinate system with axes that are normal to the planes of symmetry inherent to a material.

3.2.3.1 *Discussion*—Common usage, at least for Cartesian axes ( $123$ ,  $xyz$ , and so forth), generally assigns the coordinate system axes to the normal directions of planes of symmetry in order that the highest property value in a normal direction (for elastic properties, the axis of greatest stiffness) would be  $1$  or  $x$ , and the lowest (if applicable) would be  $3$  or  $z$ . Anisotropic materials do not have a principal material coordinate system due to the total lack of symmetry, while, for isotropic materials, any coordinate system is a principal material coordinate system. In laminated composites, the principal material coordinate system has meaning only with respect to an individual orthotropic lamina. The related term for laminated composites is “reference coordinate system.”

3.2.4 *reference coordinate system, n*—a coordinate system for laminated composites used to define ply orientations. One of the reference coordinate system axes (normally the Cartesian  $x$ -axis) is designated the reference axis, assigned a position, and the ply principal axis of each ply in the laminate is referenced relative to the reference axis to define the ply orientation for that ply.

3.2.5 *specialty orthotropic, adj*—a description of an orthotropic material as viewed in its principal material coordinate system. In laminated composites, a specialty orthotropic laminate is a balanced and symmetric laminate of the  $[0_i/90_j]_{ns}$  family as viewed from the reference coordinate system, such that the membrane-bending coupling terms of the laminate constitutive relation are zero.

3.3 *Symbols:*

$A$  = cross-sectional area of a specimen

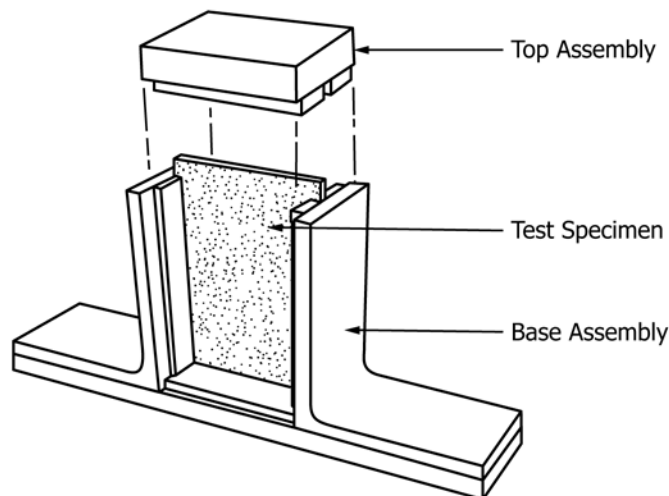

**FIG. 1 Schematic of Compressive Residual Strength Support Fixture with Specimen in Place**

$CV$  = coefficient of variation statistic of a sample population for a given property (in percent)

$D$  = damage diameter

$E^{CAI}$  = effective compressive modulus in the test direction

$F^{CAI}$  = ultimate compressive residual strength in the test direction

$h$  = specimen thickness

$l$  = specimen length

$n$  = number of specimens per sample population

$N$  = number of plies in laminate under test

$P_{max}$  = maximum force carried by test specimen prior to failure

$S_{n-1}$  = standard deviation statistic of a sample population for a given property

$w$  = specimen width

$x_i$  = test result for an individual specimen from the sample population for a given property

$\bar{x}$  = mean or average (estimate of mean) of a sample population for a given property

#### 4. Summary of Test Method

4.1 A uniaxial compression test is performed using a balanced, symmetric laminated plate, which has been damaged and inspected prior to the application of compressive force. The damage state is imparted through out-of-plane loading caused by quasi-static indentation or drop-weight impact.

4.1.1 *Quasi-Static Indentation*—The rectangular plate is damaged due to application of an out-of-plane static indentation force in accordance with Test Method **D6264/D6264M**.

4.1.2 *Drop-Weight Impact*—The rectangular plate is damaged due to application of an out-of-plane drop-weight impact in accordance with Test Method **D7136/D7136M**.

4.2 The damaged plate is installed in a multi-piece support fixture, that has been aligned to minimize loading eccentricities and induced specimen bending. The specimen/fixture assembly is placed between flat platens and end-loaded under compressive force until failure. Applied force, crosshead displacement, and strain data are recorded while loading.

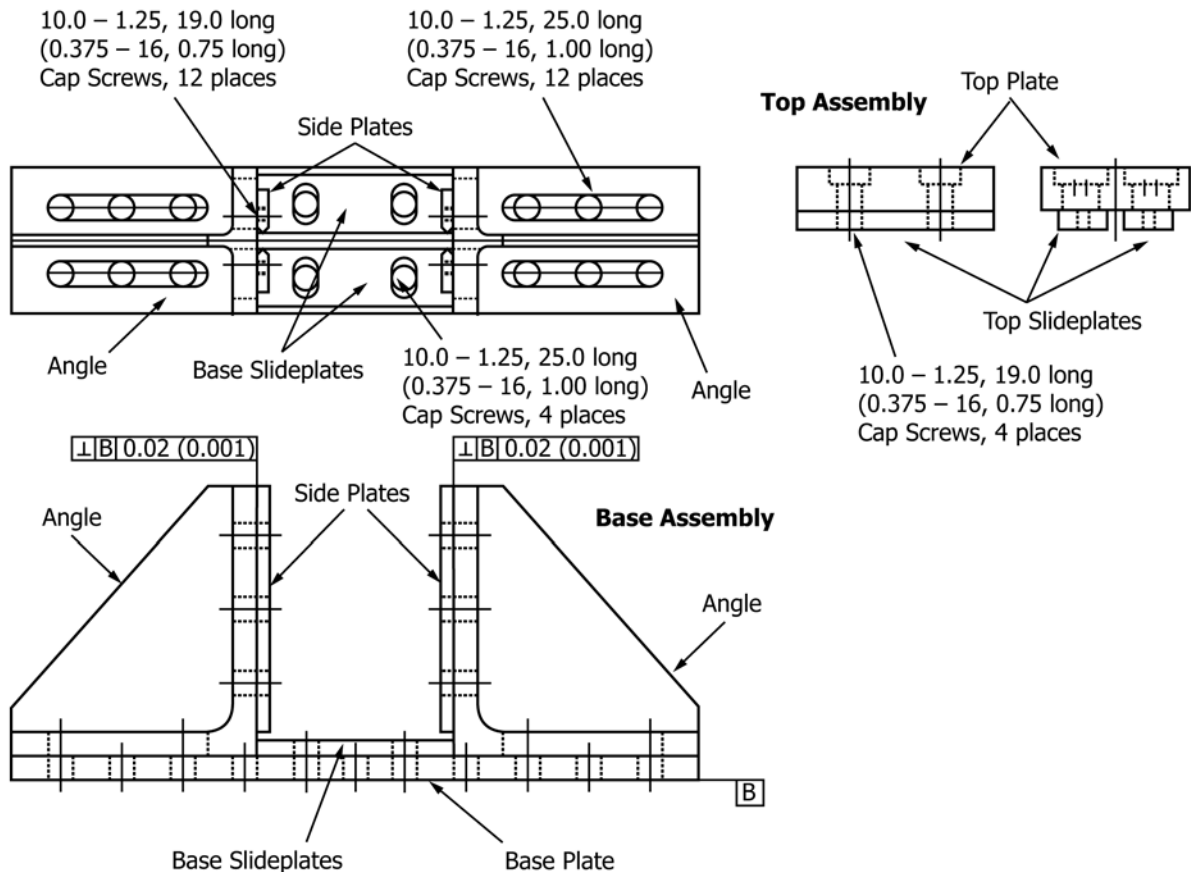

#### Notes

- 1) All dimensions in millimeters (inches) unless otherwise specified.
- 2) Dimensional tolerances are linear  $\pm 0.5$  mm ( $\pm 0.02$  in.), angular  $\pm 0.5$  degrees.
- 3) Break all edges.
- 4) Gussets on angles are optional but recommended.

FIG. 2 Support Fixture Assembly

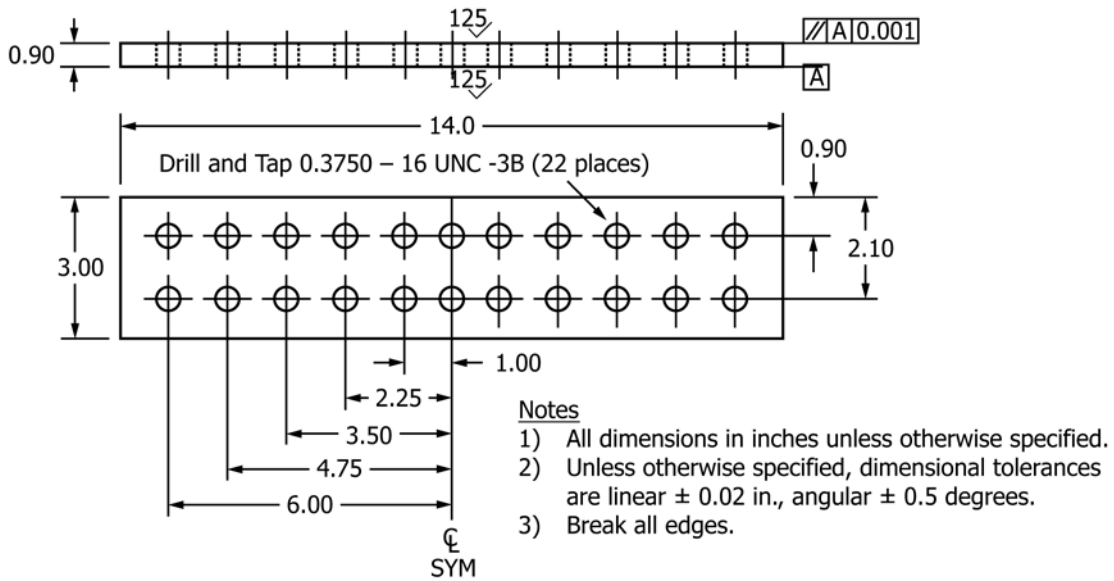

FIG. 3 Support Fixture Base Plate (Inch-Pound Version)

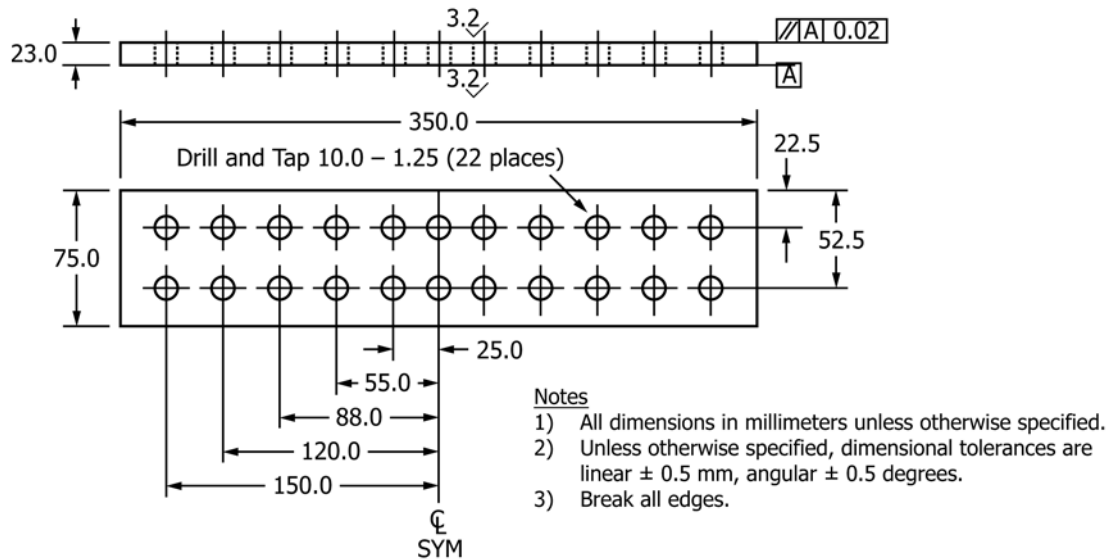

FIG. 4 Support Fixture Base Plate (SI Version)

4.3 Preferred failure modes pass through the damage in the test specimen. However, acceptable failures may initiate away from the damage site, in instances when the damage produces a relatively low stress concentration or if the extent of damage is small, or both. Unacceptable failure modes are those related to load introduction by the support fixture, local edge support conditions, and specimen instability (unless the specimen is dimensionally representative of a particular structural application).

## 5. Significance and Use

5.1 Susceptibility to damage from concentrated out-of-plane forces is one of the major design concerns of many structures made of advanced composite laminates. Knowledge of the

damage resistance and damage tolerance properties of a laminated composite plate is useful for product development and material selection.

5.2 The residual strength data obtained using this test method is most commonly used in material specifications and research and development activities. The data are not intended for use in establishing design allowables, as the results are specific to the geometry and physical conditions tested and are generally not scalable to other configurations. Its usefulness in establishing quality assurance requirements is also limited, due to the inherent variability of induced damage, as well as the dependency of damage tolerance response upon the pre-existent damage state.

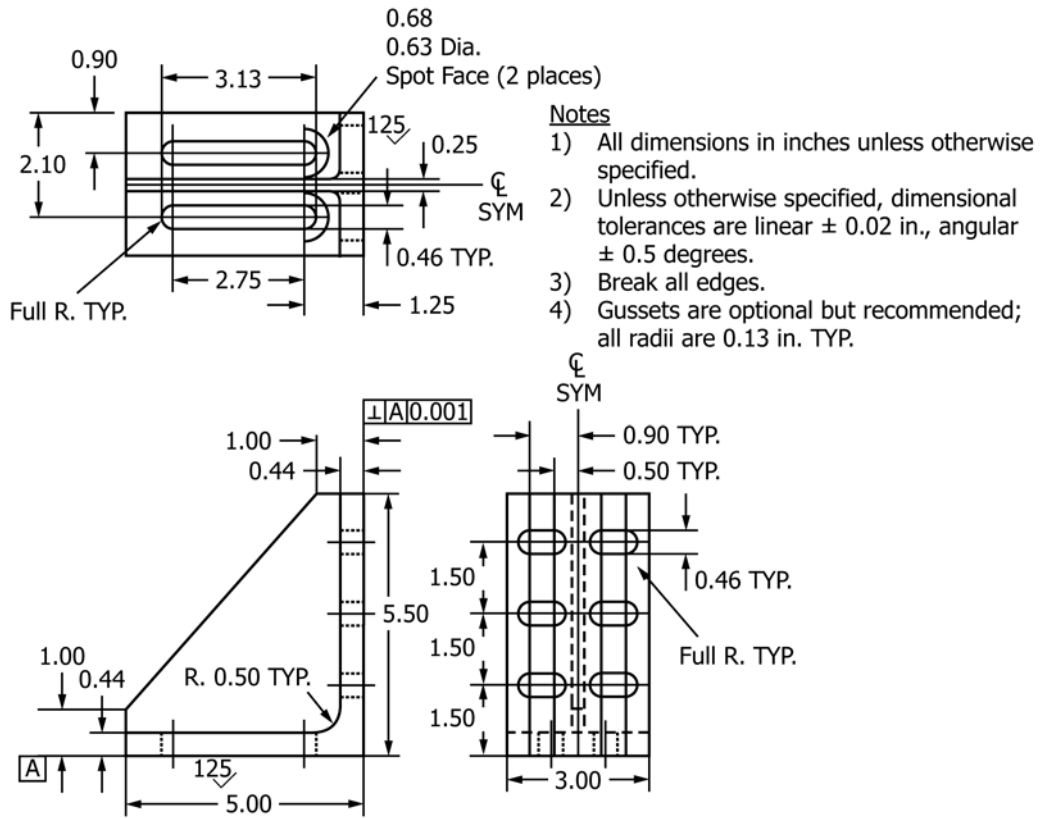

FIG. 5 Support Fixture Angles (Inch-Pound Version)

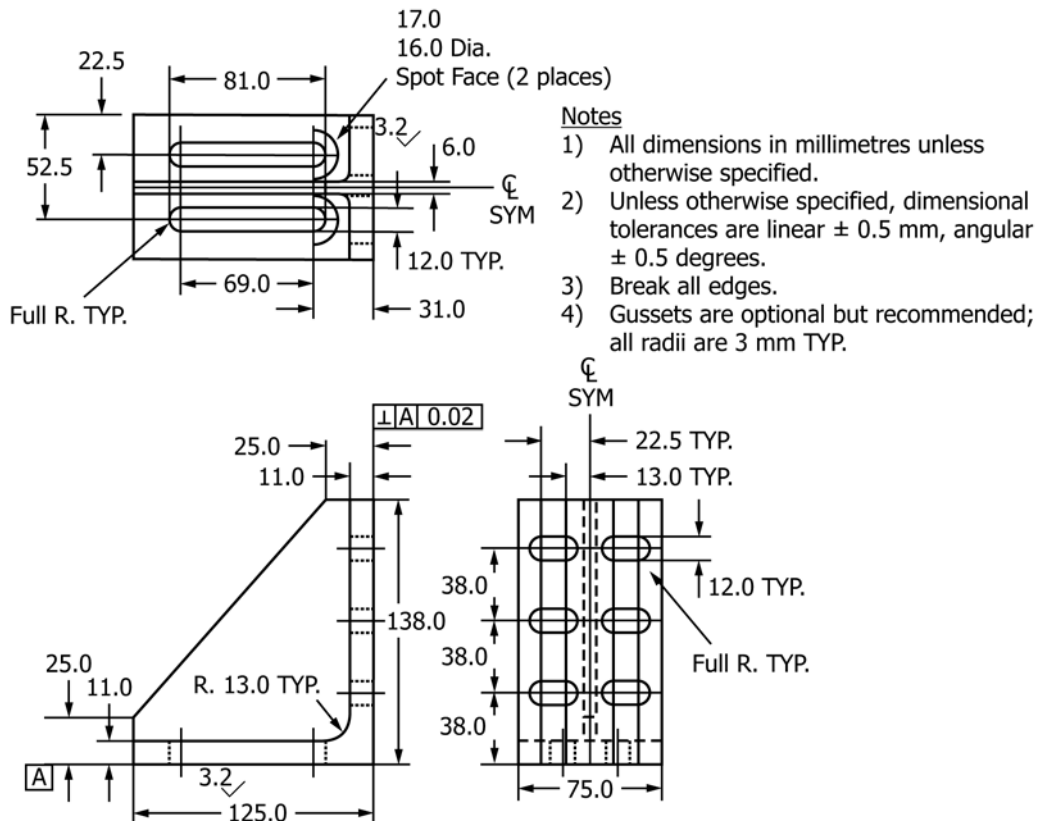
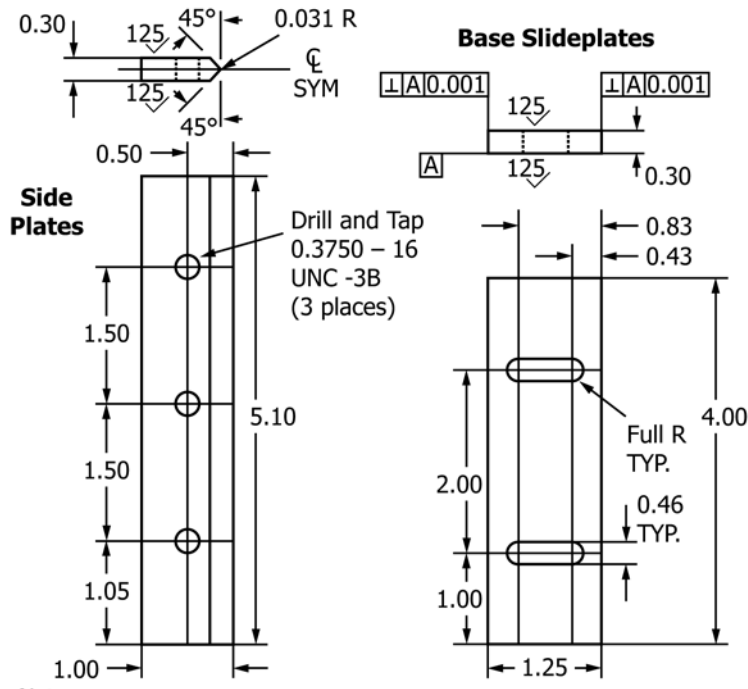

FIG. 6 Support Fixture Angles (SI Version)



**Notes**

- 1) All dimensions in inches unless otherwise specified.
- 2) Dimensional tolerances are linear  $\pm 0.02$  in., angular  $\pm 0.5$  degrees.
- 3) Break all edges.

FIG. 7 Support Fixture Side Plates and Base Slideplates (Inch-Pound Version)

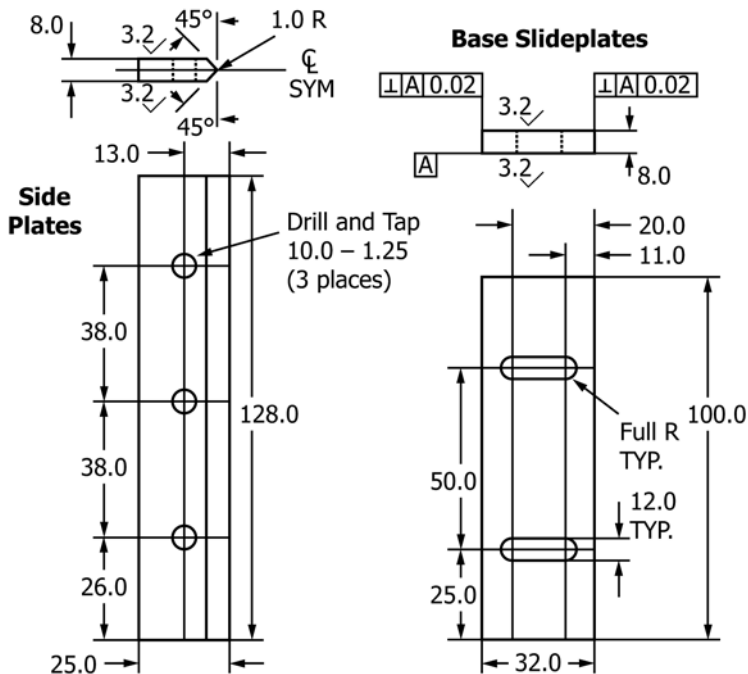

**Notes**

- 1) All dimensions in millimeters unless otherwise specified.
- 2) Dimensional tolerances are linear  $\pm 0.5$  mm, angular  $\pm 0.5$  degrees.
- 3) Break all edges.

FIG. 8 Support Fixture Side Plates and Base Slideplates (SI Version)

5.3 The properties obtained using this test method can provide guidance in regard to the anticipated damage tolerance

capability of composite structures of similar material, thickness, stacking sequence, and so forth. However, it must be

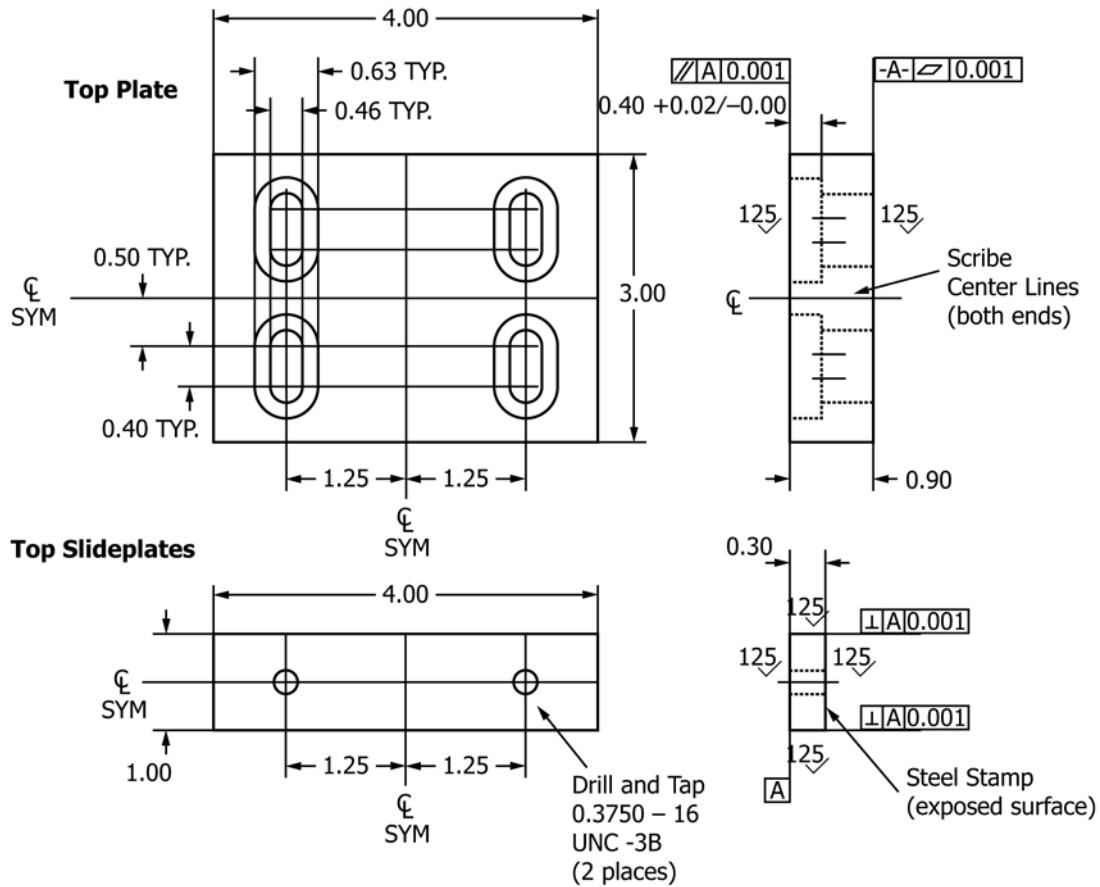

**Notes**

- 1) All dimensions in inches unless otherwise specified.
- 2) Unless otherwise specified, dimensional tolerances are linear  $\pm 0.02$  in., angular  $\pm 0.5$  degrees.
- 3) Break all edges.

**FIG. 9 Support Fixture Top Plate and Top Slideplates (Inch-Pound Version)**

understood that the damage tolerance of a composite structure is highly dependent upon several factors including geometry, stiffness, support conditions, and so forth. Significant differences in the relationships between the existent damage state and the residual compressive strength can result due to differences in these parameters. For example, residual strength and stiffness properties obtained using this test method would more likely reflect the damage tolerance characteristics of an un-stiffened monolithic skin or web than that of a skin attached to substructure which resists out-of-plane deformation. Similarly, test specimen properties would be expected to be similar to those of a panel with equivalent length and width dimensions, in comparison to those of a panel significantly larger than the test specimen.

5.4 The reporting section requires items that tend to influence residual compressive strength to be reported; these include the following: material, methods of material fabrication, accuracy of lay-up orientation, laminate stacking sequence and overall thickness, specimen geometry, specimen preparation, specimen conditioning, environment of testing, void content, volume percent reinforcement, type, size and location of damage (including method of non-destructive

inspection), specimen/fixture alignment and gripping, time at temperature, and speed of testing.

5.5 Properties that result from the residual strength assessment include the following: compressive residual strength  $F^{CAI}$ , compressive force as a function of crosshead displacement, and surface strains as functions of crosshead displacement.

**6. Interferences**

6.1 The response of a damaged specimen is dependent upon many factors, such as laminate thickness, ply thickness, stacking sequence, environment, damage type, damage geometry, damage location, and loading/support conditions. Consequently, comparisons cannot be made between materials unless identical test configurations, test conditions, and laminate configurations are used. Therefore, all deviations from the standard test configuration shall be reported in the results. Specific structural configurations and boundary conditions must be considered when applying the data generated using this test method to design applications.

6.2 *Material and Specimen Preparation*—Poor material fabrication practices, lack of control of fiber alignment, and

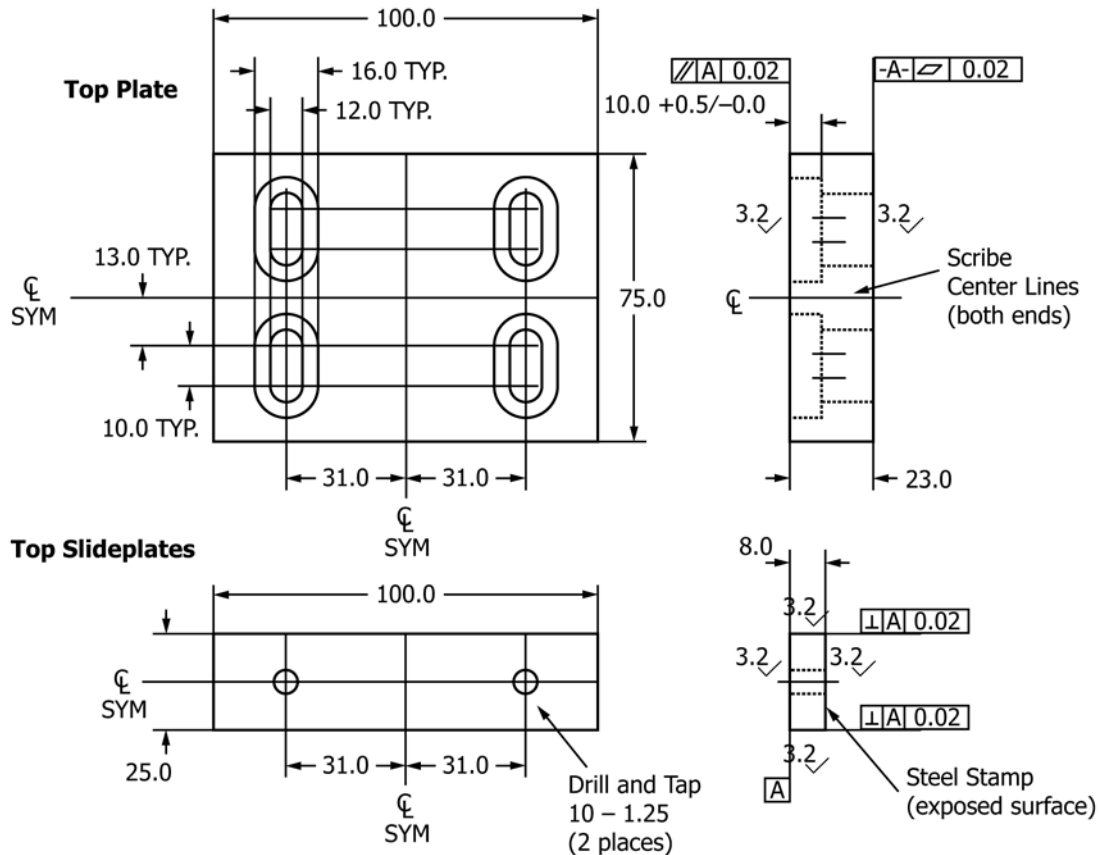

**Notes**

- 1) All dimensions in millimeters unless otherwise specified.
- 2) Unless otherwise specified, dimensional tolerances are linear  $\pm 0.5$  mm, angular  $\pm 0.5$  degrees.
- 3) Break all edges.

**FIG. 10 Support Fixture Top Plate and Top Slideplates (SI Version)**

damage induced by improper specimen machining are known causes of high material data scatter in composites in general. Important aspects of plate specimen preparation that contribute to data scatter include thickness variation, out-of-plane curvature, surface roughness, and failure to meet the dimensional and squareness tolerances (parallelism and perpendicularity) specified in 8.2.2.

6.3 *Damage Type*—Variations in the composite failure modes produced during the damaging event can contribute to strength, stiffness and strain data scatter.

6.4 *Damage Geometry and Location*—The size, shape, and location of damage (both within the plane of the plate and through-the-thickness) can affect the deformation and strength behavior of the specimens significantly. Edge effects, boundary constraints, and the damaged stress/strain field can interact if the damage size becomes too large relative to the length and width dimensions of the plate. It is recommended that the damage size be limited to half the unsupported specimen width (42 mm [1.7 in.]) to minimize interaction between damage and edge-related stress/strain fields; as the specimen has a small

length-to-width aspect ratio of 1.5, its stress/strain distribution is particularly sensitive to disturbances caused by impact or indentation damage.<sup>4</sup>

NOTE 3—To investigate the effects of larger damage sizes upon composite laminate compressive residual strength, it is recommended to examine alternative specimen and fixture designs, such as NASA 1092, which are larger and can accommodate larger damage areas without significant interaction from edge support conditions.

6.5 *Test Fixture Characteristics*—The configuration of the panel edge-constraint structure can have a significant effect on test results. In the standard test fixture, the top and bottom supports provide no clamp-up, but provide some restraint to local out-of-plane rotation due to the fixture geometry. The side supports are knife edges, which provide no rotational restraint. Edge supports must be co-planar. Results are affected by the geometry of the various slide plates local to the specimen. Results are also affected by the presence of gaps between the

<sup>4</sup> Eastland, C., Coxon, B., Avery, W., and Flynn, B., "Effects of Aspect Ratio on Test Results from Compression-Loaded Composite Coupons," *Proceedings of ICCM X*, Whistler, BC, Vol IV, A. Poursartip and K. Street, eds., Woodhead Publishing, Ltd., 1995.



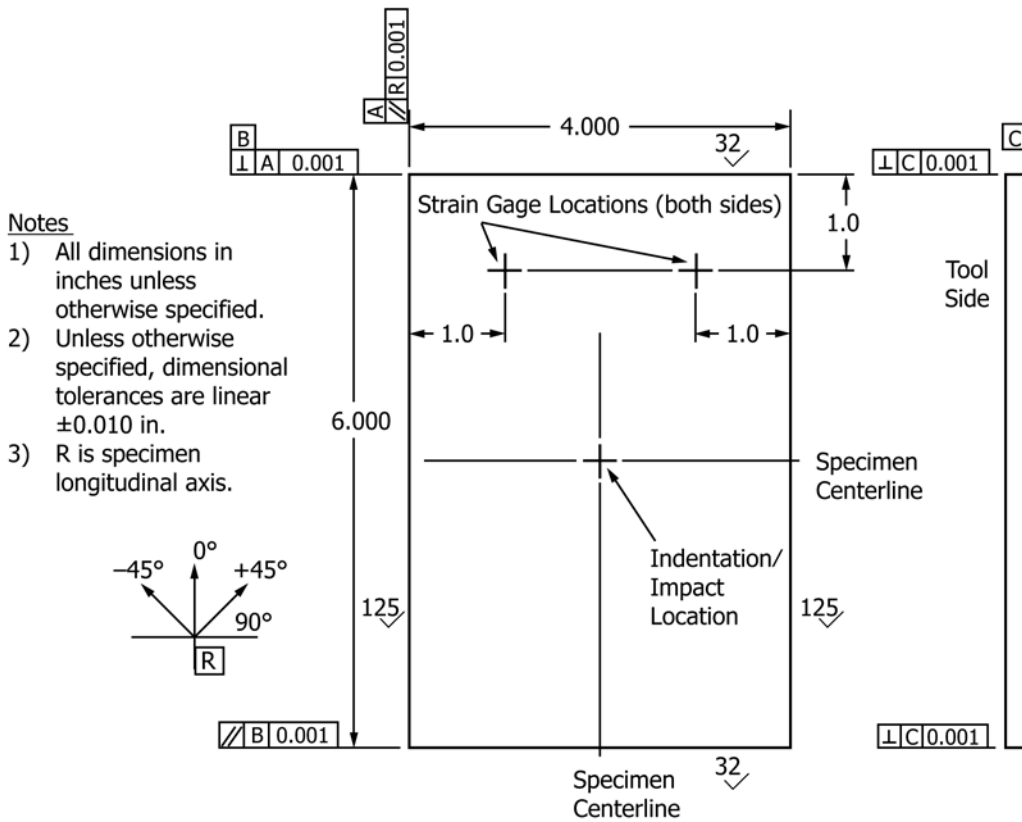

FIG. 11 Compressive Residual Strength Test Specimen (Inch-Pound Version)

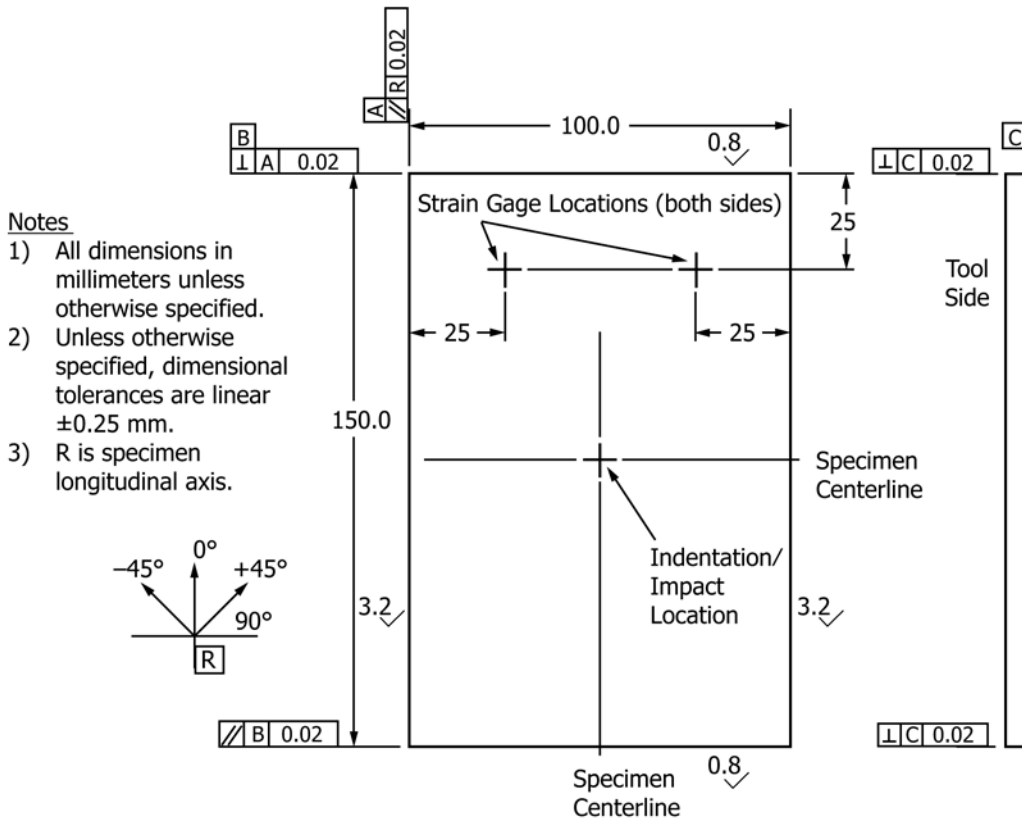
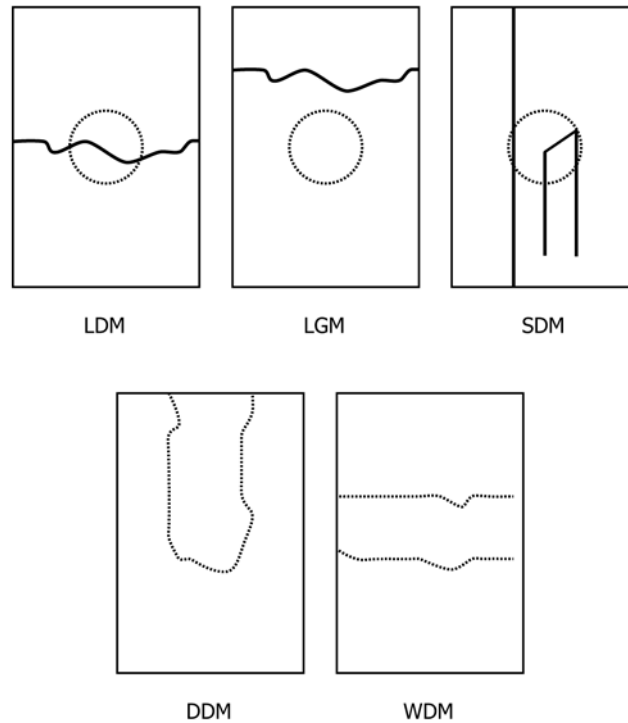

FIG. 12 Compression Residual Strength Test Specimen (SI Version)



**FIG. 13 Commonly Observed Acceptable Compressive Residual Strength Failure Modes**

slide plates and the specimen, which can reduce the effective edge support and can result in concentrated load introduction conditions at the top and bottom specimen surfaces. Additionally, results may be affected by variations in torque applied to the slide plate fasteners; loose fasteners may also reduce the effective edge support.

**6.6 System Alignment**—Errors can result if the test fixture is not centered with respect to the loading axis of the test machine, and shimmed to apply an essentially uniaxial displacement to the loaded end of the specimen.

**6.7 Material Orthotropy**—The degree of laminate orthotropy strongly affects the failure mode and measured compressive residual strength. Valid strength results should only be reported when appropriate failure modes are observed, in accordance with 11.15.

**6.8 Non-Destructive Inspection**—Non-destructive inspection (NDI) results are affected by the particular method utilized, the inherent variability of the NDI method, the experience of the operator, and so forth.

**6.9 Panel Instability**—Accurate detection of instability or incipient instability may not be possible. The nature of the damage can have a significant effect upon local flexural rigidity, which may complicate the failure mode, limiting the data only to the unique configuration tested.

## 7. Apparatus

**7.1 Micrometers**—The micrometer(s) shall use a 4 to 6 mm [0.16 to 0.25 in.] nominal diameter ball-interface on irregular surfaces such as the bag-side of a laminate, and a flat anvil interface on machined edges or very smooth tooling surfaces.

The accuracy of the instrument(s) shall be suitable for reading to within 1 % of the sample width and thickness. For typical specimen geometries, an instrument with an accuracy of  $\pm 0.0025$  mm [ $\pm 0.0001$  in.] or better is desirable for thickness measurement, while an instrument with an accuracy of  $\pm 0.025$  mm [ $\pm 0.001$  in.] or better is desirable for width and damage dimension measurement.

**7.2 Support Fixture**—The compressive test fixture, shown in Figs. 1 and 2, utilizes adjustable retention plates to support the specimen edges and inhibit buckling when the specimen is end-loaded. The fixture consists of one base plate, two base slideplates, two angles, four side plates, one top plate, and two top slideplates. Alternate fixtures with angles integrated into the base plate are permissible. The side supports are knife edges, which provide no restraint to local out-of-plane rotation. The top and bottom supports provide no clamp-up, but provide some rotational restraint due to the fixture geometry (the slide plates have a squared geometry and overlap the specimen by 8 mm [0.30 in.]). The fixture is adjustable to accommodate small variations in specimen length, width and thickness. The top plate and slide plates, which are not directly attached to the lower portion of the fixture, slip over the top edge of the test specimen. The side plates are sufficiently short to ensure that a gap between the side rails and the top plate is maintained during the test.

**7.2.1 Support Fixture Details**—Detailed drawings for manufacturing the support fixture that satisfy the requirements of this test method are contained in Figs. 3-10. Other fixtures that meet the requirements of this section may be used (for example, Wyoming Test Fixtures, Inc. Model CU-CI, Boeing BSS-7260 Type II, Airbus AITM 1.0010, SACMA SRM

2R-94).<sup>5</sup> The fixture shall be constructed of sufficient stiffness and precision as to satisfy the loading uniformity requirements of this test method. The following general notes apply to these figures:

7.2.1.1 Machine surfaces to a 3.2 [125] surface finish unless otherwise specified.

7.2.1.2 Break all edges.

7.2.1.3 The test fixture shall be made of steel. It may be made of low carbon steel for ambient temperature testing. For non-ambient environmental conditions, the recommended fixture material is a nonheat-treated ferritic or precipitation hardened stainless steel (heat treatment for improved durability is acceptable but not required).

NOTE 4—Experience has shown that fixtures may be damaged due to handling in use, thus periodic re-inspection of the fixture dimensions and tolerances is important.

7.3 *Testing Machine*—The testing machine shall be in conformance with Practices E4, and shall satisfy the following requirements:

7.3.1 *Testing Machine Configuration*—The testing machine shall have both an essentially stationary head and a movable head. A short loading train and flat end-loading platens shall be used.

7.3.2 *Flat Platens*—The test machine shall be mounted with well-aligned, fixed (as opposed to spherical seat) flat platens. The platen surfaces shall be parallel within 0.025 mm [0.001 in.] across the test fixture top plate length of 100 mm [4.0 in.]. If the platens are not sufficiently hardened, or simply to protect the platen surfaces, a hardened plate (with parallel surfaces) can be inserted between each end of the fixture and the corresponding platen. The lower platen should be marked to help center the test fixture between the platens.

7.3.3 *Drive Mechanism*—The testing machine drive mechanism shall be capable of imparting to the movable head a controlled velocity with respect to the stationary head. The velocity of the movable head shall be capable of being regulated as specified in 11.5.

7.3.4 *Force Indicator*—The testing machine force-sensing device shall be capable of indicating the total force being carried by the test specimen. This device shall be essentially free from inertia-lag at the specified rate of testing and shall indicate the force with an accuracy over the force range(s) of interest of within  $\pm 1$  % of the indicated value.

7.3.5 *Crosshead Displacement Indicator*—The testing machine shall be capable of monitoring and recording the crosshead displacement (stroke) with a precision of at least  $\pm 1$  %. If machine compliance is significant, it is acceptable to measure the displacement of the movable head using a LVDT or similar device with  $\pm 1$  % precision on displacement.

7.4 *Conditioning Chamber*—When conditioning materials at non-laboratory environments, a temperature-/vapor-level controlled environmental conditioning chamber is required that shall be capable of maintaining the required temperature to within  $\pm 3^\circ\text{C}$  [ $\pm 5^\circ\text{F}$ ] and the required relative humidity level

to within  $\pm 3$  %. Chamber conditions shall be monitored either on an automated continuous basis or on a manual basis at regular intervals.

7.5 *Environmental Test Chamber*—An environmental test chamber is required for test environments other than ambient testing laboratory conditions. This chamber shall be capable of maintaining the test specimen and fixture at the required test environment during the mechanical test. The test temperature shall be maintained within  $\pm 3^\circ\text{C}$  [ $\pm 5^\circ\text{F}$ ] of the required temperature, and the relative humidity level shall be maintained to within  $\pm 3$  % of the required humidity level.

7.6 *Strain-Indicating Device*—Strain measurement of the specimens is recommended, but not required. If strain measurement is performed, the longitudinal strain should be measured simultaneously at four locations (two locations on opposite faces of the specimen as shown in Figs. 11 and 12) to aid in ensuring application of pure compressive loading and to detect bending or buckling, or both, if any. The same type of strain transducer shall be used for all strain measurements on any single specimen. The gages, surface preparation, and bonding agents should be chosen to provide for optimal performance on the subject material for the prescribed test environment. Attachment of the strain-indicating device to the specimen shall not cause damage to the specimen surface.

NOTE 5—Although the compression test may be performed without the use of strain-indicating devices, lack of instrumentation for the damaged specimens makes the detection of undesirable panel instability much more difficult. For this reason, strain measurement of the test specimens during compressive loading is recommended.

NOTE 6—Moisture proofing of the strain gage installations on the specimen needs to be done very carefully with multiple layers of protective coatings (such as microfinned wax, high temperature Teflon tape, adhesively-bonded aluminum foil, and room temperature curing vulcanizing (RTV) compound) before subjecting them to moisture conditioning inside the environmental conditioning chamber.<sup>6</sup> Foil strain gages, protected simply with RTV compound, are likely to become corroded and unfit for hot-wet testing after approximately 100 days of moisture conditioning.

7.7 *Data Acquisition Equipment*—Equipment capable of recording force, crosshead displacement, and strain data is required.

7.8 *Alignment Plate*—If individual test specimens are not instrumented for strain measurement, an instrumented alignment plate shall be used to align the support fixture. The alignment plate should be equivalent to the test specimens in terms of material, layout, and geometry, shall be un-damaged, and shall be instrumented as described in 7.6. Alternatively, an instrumented metallic plate, equivalent in thickness to the test specimens to within  $\pm 0.25$  mm [ $\pm 0.010$  in.], may be used in support fixture alignment.

## 8. Sampling and Test Specimens

8.1 *Sampling*—Test at least five specimens per test condition unless valid results can be gained through the use of fewer specimens, as in the case of a designed experiment. For

<sup>5</sup> If you are aware of alternative suppliers, please provide this information to ASTM International Headquarters. Your comments will receive careful consideration at a meeting of the responsible technical committee,<sup>1</sup> which you may attend.

<sup>6</sup> Vijayaraju, K., Mangalgi, P. D., and Parida B. K., "Hot-Wet Compression Testing of Impact Damaged Composite Laminates," *Proceedings of the Ninth International Conference on Fracture (ICF-9)*, Sydney, Australia, 1997, pp. 909-916.

statistically significant data the procedures outlined in Practice E122 should be consulted. The method of sampling shall be reported.

### 8.2 Geometry:

**8.2.1 Stacking Sequence**—For comparison screening of the compressive residual strength of different materials, the standard specimen thickness shall be 4.0 to 6.0 mm [0.16 to 0.24 in.] with a target thickness of 5.0 mm [0.20 in.] and the laminate defined as follows:

**8.2.1.1 Unidirectional Tape**—Laminate construction shall consist of the appropriate number of unidirectional plies to achieve a total cured thickness nearest to 5.0 mm [0.20 in.] with a stacking sequence of  $[45/0/-45/90]_{NS}$  where N is a whole number. If the “nearest” thickness is less than 4.0 mm [0.16 in.], the next value of N shall be used (N+1). Recommended layups for various nominal cured ply thicknesses are provided in Table 1. The laminated plate layup is to be defined such that the 0° fiber orientation is aligned with the lengthwise (long) dimension.

**8.2.1.2 Woven Fabric**—Laminate construction shall consist of the appropriate number of fabric plies to achieve a total cured thickness nearest to 5.0 mm [0.20 in.] with a stacking sequence of  $[(+45/-45)/(0/90)]_{NS}$  where N is a whole number. If the “nearest” thickness is less than 4.0 mm [0.16 in.], the next value of N shall be used (N+1). The designations (+45/-45) and (0/90) represent a single layer of woven fabric with the warp and weft fibers oriented at the specified angles. Fabric laminates containing satin-type weaves shall have symmetric warp surfaces, unless otherwise specified and noted in the report. Recommended layups for various nominal cured ply thicknesses are provided in Table 2. The laminated plate layup is to be defined such that the 0° fiber orientation is aligned with the lengthwise (long) dimension.

**8.2.1.3 Alternative Stacking Sequences**—Laminates fabricated using other layups have been tested with acceptable failure modes using this test method. Such laminates must have multidirectional fiber orientations (fibers oriented in a minimum of three directions for tape laminates, and a minimum of two ply orientations for fabric laminates) that are both symmetric and balanced with respect to the test direction. Tests conducted using alternative stacking sequences must be designated as such, with the stacking sequence recorded and reported with any test results.

NOTE 7—Typically a  $[45_i/0_j/-45_j/90_k]_{ms}$  tape or  $[45_i/0_j]_{ms}$  fabric laminate should be selected such that a minimum of 5 % of the fibers lay in each of the four principal orientations. This laminate design has been found to yield the highest likelihood of acceptable compressive residual

**TABLE 2 Recommended Layups for Various Nominal Cured Ply Thicknesses, Woven Fabric**

Nominal Cured Ply Thickness		Ply Count	Layup
Minimum, mm [in.]	Maximum, mm [in.]		
0.085 [0.0033]	0.10 [0.004]	48	$[(45/-45)/(0/90)]_{12S}$
0.10 [0.004]	0.13 [0.005]	40	$[(45/-45)/(0/90)]_{10S}$
0.13 [0.005]	0.15 [0.006]	32	$[(45/-45)/(0/90)]_{8S}$
0.15 [0.006]	0.18 [0.007]	28	$[(45/-45)/(0/90)]_{7S}$
0.18 [0.007]	0.20 [0.008]	24	$[(45/-45)/(0/90)]_{6S}$
0.20 [0.008]	0.25 [0.010]	20	$[(45/-45)/(0/90)]_{5S}$
0.25 [0.010]	0.36 [0.014]	16	$[(45/-45)/(0/90)]_{4S}$
0.36 [0.014]	0.50 [0.020]	12	$[(45/-45)/(0/90)]_{3S}$
0.50 [0.020]	1.00 [0.040]	8	$[(45/-45)/(0/90)]_{2S}$
1.00 [0.040]	1.50 [0.060]	4	$[(45/-45)/(0/90)]_S$

strength failure modes, and has produced indentation/impact damage states which can be well characterized using the procedures described in this test method and in Test Method D7136/D7136M. Laminates with fewer fiber/ply directions can exhibit complex damage geometries which are much more difficult to characterize.

**8.2.2 Specimen Configuration**—The geometry of the plate specimen is shown in Figs. 11 and 12.

**8.3 Specimen Preparation**—Guide D5687/D5687M provides recommended specimen preparation practices and should be followed where practical.

**8.3.1 Panel Fabrication**—Control of fiber alignment is critical. Improper fiber alignment will reduce the measured properties. The panel must be flat and of uniform thickness to assure even loading. Erratic fiber alignment will also increase the coefficient of variation. Report the panel fabrication method. Specimens shall be of uniform cross-section over the entire surface and shall not have a thickness taper greater than 0.08 mm [0.003 in.] in any direction across the length and width of the specimen. The coefficient of variation for thickness measurements taken in 11.2.3 should be less than 2 %.

**8.3.2 Machining Methods**—Specimen preparation is extremely important for this specimen. Take precautions when cutting specimens from large panels to avoid notches, undercuts, rough or uneven surfaces, or delaminations due to inappropriate machining methods. Obtain final dimensions by water-lubricated precision sawing, milling, or grinding. The use of diamond-tipped tooling (as well as water-jet cutting) has been found to be extremely effective for many material systems. Edges should be flat and parallel within the specified tolerances. Machining tolerances and surface finish requirements are as noted in Figs. 11 and 12. Record and report the specimen cutting methods.

**8.3.3 Labeling**—Label the plate specimens so that they will be distinct from each other and traceable back to the raw material, and will neither influence the test nor be affected by it.

## 9. Calibration

9.1 The accuracy of all measuring equipment shall have certified calibrations that are current at the time of use of the equipment.

## 10. Conditioning

10.1 The recommended pre-test condition is effective moisture equilibrium at a specific relative humidity as established

**TABLE 1 Recommended Layups for Various Nominal Cured Ply Thicknesses, Unidirectional Tape**

Nominal Cured Ply Thickness		Ply Count	Layup
Minimum, mm [in.]	Maximum, mm [in.]		
0.085 [0.0033]	0.10 [0.004]	48	$[45/0/-45/90]_{6S}$
0.10 [0.004]	0.13 [0.005]	40	$[45/0/-45/90]_{5S}$
0.13 [0.005]	0.18 [0.007]	32	$[45/0/-45/90]_{4S}$
0.18 [0.007]	0.25 [0.010]	24	$[45/0/-45/90]_{3S}$
0.25 [0.010]	0.50 [0.020]	16	$[45/0/-45/90]_{2S}$
0.50 [0.020]	0.75 [0.030]	8	$[45/0/-45/90]_S$

by Test Method **D5229/D5229M**; however, if the test requestor does not explicitly specify a pre-test conditioning environment, no conditioning is required and the test specimens may be tested as prepared.

10.2 The pre-test specimen conditioning process, to include specified environmental exposure levels and resulting moisture content, shall be reported with the test data.

NOTE 8—The term moisture, as used in Test Method **D5229/D5229M**, includes not only the vapor of a liquid and its condensate, but the liquid itself in large quantities, as for immersion.

10.3 If not explicit conditioning process is performed the specimen conditioning process shall be reported as “unconditioned” and the moisture content as “unknown”.

## 11. Procedure

### 11.1 *Parameters to be Specified Prior to Test:*

11.1.1 The specimen sampling method, specimen type and geometry, and conditioning travelers (if required).

11.1.2 The compressive properties and data reporting format desired.

NOTE 9—Determine specific material property, accuracy, and data reporting requirements prior to test for proper selection of instrumentation and data recording equipment. Estimate the specimen strength and strain response to aid in transducer selection, calibration of equipment, and determination of equipment settings.

11.1.3 The environmental conditioning test parameters.

11.1.4 Method of imparting damage to the specimen (static indentation or drop-weight impact) and associated parameters.

11.1.5 Strain gage requirements and related calculations.

11.1.6 If performed, sampling method, plate specimen geometry, and test parameters used to determine density and reinforcement volume.

### 11.2 *General Instructions:*

11.2.1 Report any deviations from this test method, whether intentional or inadvertent.

11.2.2 If specific gravity, density, reinforcement volume, or void volume are to be reported, then obtain these samples from the same panels being tested. Specific gravity and density may be evaluated by means of Test Method **D792**. Volume percent of the constituents may be evaluated by one of the procedures of Test Methods **D3171**.

11.2.3 Following final specimen machining, but before all testing, measure the specimen width,  $w$ , and length,  $l$ , at two locations in the vicinity of the location to be damaged. The thickness of the specimen shall be measured at four locations near the damage location, and recorded as the average of the four measurements. The accuracy of all measurements shall be within 1 % of the dimension. Record the dimensions to three significant figures in units of millimetres [inches].

### 11.3 *Damage Infliction:*

11.3.1 *Quasi-Static Indentation*—If the specimen is to be damaged through application of a quasi-static indentation force, impart damage in accordance with Test Method **D6264/D6264M**.

11.3.2 *Drop-Weight Impact*—If the specimen is to be damaged through an out-of-plane drop-weight impact, impart damage in accordance with Test Method **D7136/D7136M**.

11.4 Condition the specimens as required. Store the specimens in the conditioned environment until test time, if the test environment is different than the conditioning environment.

NOTE 10—Damage infliction prior to conditioning will likely cause different results than conditioning prior to damage infliction. For example, damage infliction prior to moisture conditioning will likely decrease damage resistance; as a plate specimen is more likely to be more flexurally rigid prior to conditioning, it is more likely to absorb the impact or indentation energy through damage formation. Also, moisture absorption will be locally accelerated in the region of the damage site if the specimen is conditioned after damage is inflicted.

11.5 *Speed of Testing*—Set the speed of testing so as to produce failure within 1 to 10 min. If the ultimate strength of the material cannot be reasonably estimated, initial trials should be conducted using standard speeds until the ultimate strength of the material and the compliance of the system are known, and speed of testing can be adjusted. The suggested standard crosshead displacement rate is 1.25 mm/min [0.05 in./min].

11.6 *Test Environment*—If possible, test the specimen under the same fluid exposure level used for conditioning. However, cases such as elevated temperature testing of a moist specimen place unrealistic requirements on the capabilities of common testing machine environmental chambers. In such cases the mechanical test environment may need to be modified, for example, by testing at elevated temperature with no fluid exposure control. Testing shall be completed within a specified time limit to failure (typically 10 to 30 min) after withdrawal from the conditioning chamber. Record any modifications to the test environment.

NOTE 11—When testing a conditioned specimen at elevated temperature with no fluid exposure control, the percentage moisture loss of the specimen prior to test completion may be estimated by placing a conditioned traveler coupon of known weight within the test chamber at the same time the specimen is placed in the chamber. Upon completion of the test, the traveler coupon is removed from the chamber, weighed and the percentage weight calculated and reported.

### 11.7 *Specimen/Alignment Plate Installation:*

11.7.1 If individual specimens are not instrumented for strain measurement, perform 11.7.2 through 11.11 using the instrumented alignment plate, in lieu of a test specimen, prior to testing each sample of like specimens.

11.7.2 Check the fixtures for conformity to the enclosed figures. Adjust the position of the angles such that 0.8 to 1.5 mm [0.03 to 0.06 in.] clearance will be present between each angle and the edge of the test specimen. Torque the fixture screws attaching the angles to the base plate to approximately 7 N·m [60 in.-lbf].

11.7.3 Install the test specimen into the compression residual strength fixture such that the machined ends of the specimen are flush with the ends of the fixture halves. This should result in the damaged location being centered within the fixture. Support the specimen using the side plates attached to the angles and the slideplates attached to the base plate. Align the specimen by adjusting the side and slide plates, making sure that the specimen is held perpendicular to the base plate of the test fixture. Hand tighten the screws of the side and slide plates to ensure lateral support for the specimen. Put the top plate on top of the specimen. Hand tighten the screws on the slide plates on the top plate to support the specimen securely.

11.7.4 Check for gaps between the specimen and side/slide plates using a feeler gage, and adjust the side/slide plates or shim as necessary to ensure the gaps are less than 0.05 mm [0.002 in.].

11.8 *Fixture Insertion*—Place the fixture in between the flat platens of the testing machine, taking care to align the vertical axis of the fixture with the test direction. Center the fixture using the markings described in 7.3.2.

11.9 *Strain Gage Preparation*—Attach strain gage lead wires to the data acquisition apparatus. To determine the effective compression modulus, the laminate stress must be measured at two specified strain levels, typically 1000 and 3000 microstrain (see 13.2). If bending of the specimen is occurring at any strain level, the strains measured on the opposite faces of the specimen (on the back-to-back strain gages) will not be equal. The average of the two back-to-back strain values is the desired strain since the amount of bending does not affect the average strain. However, the percent bending must be kept to less than 10 %.

11.10 *Preloading*—Apply 450 N [100 lbf] compressive force to the specimen/fixture assembly, in order to ensure all loading surfaces are in contact and to align the platens if necessary. Reduce the compressive force to 150 N [35 lbf], and re-zero and balance all instrumentation.

11.11 *Alignment Loading:*

11.11.1 Torque the fixture screws attaching the side and slide plates to approximately 7 N·m [60 in.-lbf].

11.11.2 Apply compressive force to the specimen at the specified rate while recording data, until approximately 10 % of the anticipated ultimate force is achieved. Reduce the compressive force to 150 N [35 lbf] at an equivalent unloading rate and check strain gage output for proper alignment.

11.11.3 Review the recorded strain gage data for evidence of specimen bending. A difference in the stress-strain or force-strain slope from opposite faces of the specimen indicates bending in the specimen. Determine percent bending at the maximum applied force for each of the back-to-back gage locations using Eq 1:

$$B_y = \text{Percent Bending} = \frac{\epsilon_1 - \epsilon_2}{\epsilon_1 + \epsilon_2} \cdot 100 \quad (1)$$

where:

$\epsilon_1$  = indicated strain from gage on one face, and

$\epsilon_2$  = indicated strain from gage on opposite face.

The sign of the calculated percent bending indicates the direction in which the bending is occurring. This information is useful in determining if the bending is being introduced by a systematic error in the test specimen, testing apparatus, or test procedure, rather than by random effects from test to test.

11.11.4 Rapid divergence of the strain readings on the opposite faces of the specimen, or rapid increase in percent bending, is indicative of the onset of panel instability. If either of these conditions is found to exist in the strain gage data, or if percent bending at the maximum applied force exceeds 10 %, examine the fixture, specimen and load platens for conditions which may promote specimen bending, such as the presence of gaps, loose fasteners or platen misalignment.

Loosen the fixture screws and adjust the side and slide plates (as in 11.7) and the platens (as in 11.10) as necessary to minimize bending of the specimen at the specified low magnitude of compressive force. Repeat 11.11.1 through 11.11.3 to ensure that the specimen does not buckle or undergo excessive bending prior to final loading.

11.12 *Alignment Plate Removal/Specimen Installation*—If individual specimens are not instrumented for strain measurement, remove the compressive force from the support fixture, and move the upper platen a sufficient distance away from the support fixture such that the top plate may be accessed. Remove strain gage lead wires from the data acquisition apparatus. Loosen the fixture screws attaching the side and slide plates, and remove the alignment plate from the support fixture. Install the test specimen into the support fixture as described in 11.7.3. Preload the specimen as described in 11.10. Torque the fixture screws attaching the side and slide plates to approximately 7 N·m [60 in.-lbf].

NOTE 12—The test fixture does not need to be re-aligned after each test, when testing a sample of like specimens.

11.13 *Loading*—Apply the compressive force to the specimen at the specified rate while recording data. The specimen is loaded until a force maximum is reached and force has dropped off about 30 % from the maximum. Unless specimen rupture is specifically desired, the test is terminated so as to prevent masking of the true failure mode by large-scale distortion, in order to provide a more representative failure mode assessment, and to prevent support fixture damage.

11.14 *Data Recording*—Record force versus crosshead displacement and force versus strain (if performed) continuously, or at frequent regular intervals; for this test method, a sampling rate of 2 to 3 data recordings per second, and a target minimum of 100 data points per test are recommended. If a compliance change or initial ply failures are noted, record the force, displacement (and strain if available), and mode of damage at such points. If the specimen is to be failed, record the maximum force, the failure force, and the crosshead displacement at, or as near as possible to, the moment of rupture.

NOTE 13—Other valuable data that can be useful in understanding testing anomalies and gripping or specimen slipping problems includes force versus strain data, percent edgewise bending and force versus time data.

11.15 *Failure Modes*—Record the mode, area, and location of failure for each specimen. Three-place failure mode descriptors, summarized in Table 3, shall be used. This notation uses the first place to describe failure type, the second to describe failure area, and the last to describe failure location. Fig. 13 illustrates commonly observed acceptable failure modes. All of the failure modes in the “First Character” column of Table 3 are acceptable, with the exception of end-crushing, edge-restrained delamination growth (for which delamination(s) grow prior to final failure and additional force-carrying capability results from edge restraint) or panel instability (unless the specimen is dimensionally representative of a particular structural application). Edge-restrained delamination growth and panel instability failures cannot be determined by

**TABLE 3 Three-Place Failure Mode Codes**

First Character		Second Character		Third Character	
Failure Type	Code	Failure Area	Code	Failure Location	Code
Angled	A	At end/edge	A	Bottom	B
Brooming	B	at/through Damage	D	Left	L
end-Crushing	C	Gage, away from damage	G	Middle	M
Delamination growth to edge at final failure, lengthwise	D	Multiple areas	M	Right	R
through-thickness	H	Various	V	Top	T
panel Instability	I	Unknown	U	Various	V
Kink bands	K			Unknown	U
Lateral	L				
Multimode	M(xyz)				
delamination growth to edge prior to final failure, Restrained by edge	R				
long, Splitting	S				
delamination growth to edge at final failure, Widthwise	W				
explosive	X				
Other	O				

visual inspection of the specimen during or after test; they must be determined through inspection of the stress-strain or force-strain curves.

NOTE 14—Techniques such as shadow moiré can be beneficial to the visual detection of panel instability and edge-restrained delamination growth. The specimen should be monitored on both sides when using such techniques.

NOTE 15—Gage failures (away from the induced damage) are considered acceptable, but may not provide a true measurement of the residual strength of the specimen for the induced damage state. A gage failure may indicate that the panel is not sensitive to the induced damage, such that it fails at a compressive stress near the panel's undamaged strength. Alternatively, a gage failure may indicate that undetected damage or a flaw was in the vicinity of the failure, such that the measured failure stress is lower than the panel's undamaged strength as well as its failure stress for the detected damage.

## 12. Validation

12.1 Values for ultimate properties shall not be calculated for any specimen that breaks at some obvious flaw, unless such flaw constitutes a variable being studied. Retests shall be performed for any specimen on which values are not calculated.

12.2 Minor end crushing before final failure in the gage section sometimes occurs. If this end crushing arrests, and a valid gage section failure ultimately is achieved, end crushing does not necessarily invalidate the test.

12.3 The onset of panel instability or excessive bending invalidates the test. For the test results to be considered valid, percent bending shall be less than 10 % as determined by Eq 1. Determine percent bending at the midpoint of the strain range used for effective chord modulus calculations (see 13.2). The same requirement shall be met at the failure strain for the strength and strain-to-failure data to be considered valid. If possible, a plot of percent bending versus average strain should be recorded to aid in the determination of failure mode.

12.4 A significant fraction of failures in a sample population occurring away from the damage location shall be cause to re-examine the means of force introduction into the material. Factors considered should include the fixture alignment, gaps between side/slide plates and specimen, slide plate fastener torque, specimen thickness taper, and uneven machining of specimen ends.

## 13. Calculation

13.1 *Ultimate Strength*—Calculate the ultimate compressive residual strength using Eq 2 and report the results to three significant figures.

$$F^{CAI} = P_{max}/A \quad (2)$$

where:

$F^{CAI}$  = ultimate compressive residual strength, MPa [psi],  
 $P_{max}$  = maximum force prior to failure, N [lbf], and  
 $A$  = cross-sectional area =  $h \cdot w$ , mm<sup>2</sup> [in.<sup>2</sup>].

13.2 *Effective Modulus*—Calculate the effective compressive modulus using Eq 3 and report the results to three significant figures. The applied force at 1000 and 3000 microstrain is to be based upon the average strain for all four strain gages.

$$E^{CAI} = (P_{3000} - P_{1000})/((\epsilon_{3000} - \epsilon_{1000}) \cdot A) \quad (3)$$

where:

$E^{CAI}$  = effective compressive modulus, MPa [psi],  
 $P_{3000}$  = applied force corresponding to  $\epsilon_{3000}$ , N [lbf],  
 $P_{1000}$  = applied force corresponding to  $\epsilon_{1000}$ , N [lbf],  
 $\epsilon_{3000}$  = recorded strain value closest to 3000 microstrain, and  
 $\epsilon_{1000}$  = recorded strain value closest to 1000 microstrain.

13.3 *Statistics*—For each series of tests calculate the average value, standard deviation, and coefficient of variation (in percent) for ultimate compressive residual strength:

$$\bar{x} = \left( \sum_{i=1}^n x_i \right) / n \quad (4)$$

$$S_{n-1} = \sqrt{\left( \sum_{i=1}^n x_i^2 - n \bar{x}^2 \right) / (n - 1)} \quad (5)$$

$$CV = 100 \times S_{n-1} / \bar{x} \quad (6)$$

where:

$\bar{x}$  = sample mean (average),  
 $S_{n-1}$  = sample standard deviation,  
 $CV$  = sample coefficient of variation, %,  
 $n$  = number of specimens, and  
 $x_i$  = measured or derived property.

## 14. Report

14.1 Report the following information, or references pointing to other documentation containing this information, to the maximum extent applicable (reporting of items beyond the control of a given testing laboratory, such as might occur with material details or panel fabrication parameters, shall be the responsibility of the requestor):

NOTE 16—Guides E1309 and E1434 contain data reporting recommendations for composite materials and composite materials mechanical testing.

14.1.1 The revision level or date of issue of this test method.

14.1.2 The name(s) of the test operator(s).

14.1.3 Any variations to this test method, anomalies noticed during testing, or equipment problems occurring during testing.

14.1.4 Identification of all the materials constituent to the plate specimen tested, including for each: material specification, material type, manufacturer's material designation, manufacturer's batch or lot number, source (if not from manufacturer), date of certification, expiration of certification, filament diameter, tow or yarn filament count and twist, sizing, form or weave, fiber areal weight, matrix type, matrix content, and volatiles content.

14.1.5 Description of the fabrication steps used to prepare the parent laminate including: fabrication start date, fabrication end date, process specification, cure cycle, consolidation method, and a description of the equipment used.

14.1.6 Ply orientation and stacking sequence of the laminate, relative to the longitudinal (long) dimension.

14.1.7 If requested, report density, volume percent reinforcement, and void content test methods, specimen sampling method and geometries, test parameters, and test results.

14.1.8 Method of preparing the test specimen, including specimen labeling scheme and method, specimen geometry, sampling method, and specimen cutting method.

14.1.9 Calibration dates and methods for all measurements and test equipment.

14.1.10 Type of test machine, alignment results, and data acquisition sampling rate and equipment type.

14.1.11 Measured length, width and thickness for each specimen (prior to and after damage and conditioning, if appropriate).

14.1.12 Weight of specimen.

14.1.13 Conditioning parameters, results, and sequence (conditioning prior to damage infliction, or vice versa).

14.1.14 Relative humidity and temperature of the testing laboratory.

14.1.15 Environment of the test machine environmental chamber (if used) and soak time at test environment.

14.1.16 Number of specimens tested.

14.1.17 Method of damage infliction (static indentation or drop-weight impact).

14.1.18 For specimens damaged through static indentation, all appropriate parameters in accordance with Test Method D6264/D6264M.

14.1.19 For specimens damaged through drop-weight impact, all appropriate parameters in accordance with Test Method D7136/D7136M.

14.1.20 Method of support fixture alignment (individual specimen instrumentation, or use of an alignment plate).

14.1.21 Speed of compressive residual strength testing.

14.1.22 Individual ultimate compressive residual strengths and average value, standard deviation, and coefficient of variation (in percent) for the population.

14.1.23 Individual effective modulus and average value, standard deviation, and coefficient of variation (in percent) for the population if strain measurement of specimens is performed.

14.1.24 Force versus crosshead displacement data for each specimen so evaluated.

14.1.25 Strain gage type, stress-strain curves, tabulated stress versus strain data, or percent bending versus force or head displacement, or any combination thereof for each specimen so evaluated.

14.1.26 Failure mode and location of failure for each specimen.

## 15. Precision and Bias

15.1 *Precision*—The data required for the development of a precision statement is not available for this test method. Committee D30 is currently planning a round-robin test series for this test method in order to determine precision.

15.2 *Bias*—Bias cannot be determined for this test method as no acceptable reference standard exists.

## 16. Keywords

16.1 composite materials; compression after impact; compression testing; compressive residual strength; damage tolerance

*ASTM International takes no position respecting the validity of any patent rights asserted in connection with any item mentioned in this standard. Users of this standard are expressly advised that determination of the validity of any such patent rights, and the risk of infringement of such rights, are entirely their own responsibility.*

*This standard is subject to revision at any time by the responsible technical committee and must be reviewed every five years and if not revised, either reapproved or withdrawn. Your comments are invited either for revision of this standard or for additional standards and should be addressed to ASTM International Headquarters. Your comments will receive careful consideration at a meeting of the responsible technical committee, which you may attend. If you feel that your comments have not received a fair hearing you should make your views known to the ASTM Committee on Standards, at the address shown below.*

*This standard is copyrighted by ASTM International, 100 Barr Harbor Drive, PO Box C700, West Conshohocken, PA 19428-2959, United States. Individual reprints (single or multiple copies) of this standard may be obtained by contacting ASTM at the above address or at 610-832-9585 (phone), 610-832-9555 (fax), or service@astm.org (e-mail); or through the ASTM website (www.astm.org). Permission rights to photocopy the standard may also be secured from the Copyright Clearance Center, 222 Rosewood Drive, Danvers, MA 01923, Tel: (978) 646-2600; http://www.copyright.com/*