



# Standard Test Method for Rapid Determination of Corrosiveness to Copper from Petroleum Products Using a Disposable Copper Foil Strip<sup>1</sup>

This standard is issued under the fixed designation D7095; the number immediately following the designation indicates the year of original adoption or, in the case of revision, the year of last revision. A number in parentheses indicates the year of last reapproval. A superscript epsilon ( $\epsilon$ ) indicates an editorial change since the last revision or reapproval.

## INTRODUCTION

This test method is similar in nature to the Test Method **D130** test method, but involves three major differences. Firstly, a single-use copper foil strip is used in place of the Test Method **D130** multi-use copper strip. Secondly, a different polishing technique is used in preparing the copper foil strip, which uses a commercially available scouring-pad in place of the initial and final polishing techniques described in Test Method **D130**. Thirdly, this test method involves a shorter analysis time of 45 minutes for all product types as compared to the Test Method **D130** method requirements, which are longer; for example, two or three hours.

## 1. Scope

1.1 This test method covers the determination of the corrosiveness to copper of aviation gasoline, aviation turbine fuel, automotive gasoline, natural gasoline, or other hydrocarbons having a vapor pressure no greater than 124 kPa (18 psi), cleaners (for example, Stoddard solvent), kerosine, diesel fuel, distillate fuel oil, lubricating oil, and other petroleum products.

1.2 The values stated in SI units are to be regarded as the standard. The values in parentheses are provided for information only.

1.3 *This standard does not purport to address all of the safety concerns, if any, associated with its use. It is the responsibility of the user of this standard to establish appropriate safety and health practices and determine the applicability of regulatory limitations prior to use.* For specific warning statements, see **6.1**, **10.1.1**, and **Annex A2**.

## 2. Referenced Documents

2.1 *ASTM Standards:*<sup>2</sup>

**B152/B152M Specification for Copper Sheet, Strip, Plate, and Rolled Bar**

**D130 Test Method for Corrosiveness to Copper from Petro-**

**leum Products by Copper Strip Test**

**D396 Specification for Fuel Oils**

**D975 Specification for Diesel Fuel Oils**

**D1655 Specification for Aviation Turbine Fuels**

**D1838 Test Method for Copper Strip Corrosion by Liquefied Petroleum (LP) Gases**

**D4057 Practice for Manual Sampling of Petroleum and Petroleum Products**

**D4177 Practice for Automatic Sampling of Petroleum and Petroleum Products**

**D6615 Specification for Jet B Wide-Cut Aviation Turbine Fuel**

**E1 Specification for ASTM Liquid-in-Glass Thermometers**

2.2 *ASTM Adjuncts:*

**ASTM Copper Strip Corrosion Standard<sup>3</sup>**

## 3. Summary of Test Method

3.1 A polished copper foil strip is immersed in a specific volume of the sample being tested and heated under conditions of temperature and time that are specific to the class of material being tested. At the end of the heating period, the copper foil strip is removed, washed, and the color and tarnish level assessed against the ASTM Copper Strip Corrosion Standard.

## 4. Significance and Use

4.1 Crude petroleum contains sulfur compounds, most of which are removed during refining. However, of the sulfur compounds remaining in the petroleum product, some can have

<sup>1</sup> This test method is under the jurisdiction of ASTM Committee **D02** on Petroleum Products, Liquid Fuels, and Lubricants and is the direct responsibility of Subcommittee **D02.05** on Properties of Fuels, Petroleum Coke and Carbon Material.

Current edition approved May 1, 2014. Published July 2014. Originally approved in 2004. Last previous edition approved in 2009 as D7095 - 04 (2009). DOI: 10.1520/D7095-04R14.

<sup>2</sup> For referenced ASTM standards, visit the ASTM website, [www.astm.org](http://www.astm.org), or contact ASTM Customer Service at [service@astm.org](mailto:service@astm.org). For *Annual Book of ASTM Standards* volume information, refer to the standard's Document Summary page on the ASTM website.

<sup>3</sup> Available from ASTM International Headquarters. Request Adjunct No. **ADJD0130**. Names of suppliers in the United Kingdom can be obtained from Energy Institute, 61 New Cavendish St., London, W1M 8AR, United Kingdom. One Master Standard is held at Energy Institute for reference.

a corroding action on various metals, including copper, and this corrosivity is not necessarily related to the total sulfur content. The effect can vary according to the chemical types of sulfur compounds present. This copper foil strip corrosion test is designed to assess the relative degree of corrosivity of a petroleum product towards copper and copper-containing alloys using a shorter test duration than that specified in Test Method D130.

4.2 Some sulfur species may become corrosive to copper only at higher temperatures. Thus, higher test temperatures, particularly 100°C (212°F), may be used to test some products by the pressure vessel procedure.

### 5. Apparatus

5.1 *Copper Foil Strip Corrosion Test Pressure Vessel*, constructed from stainless steel according to the dimensions given in Fig. 1. The vessel shall be capable of withstanding a test pressure of 700 kPa gage (100 psi). Alternative designs for the vessel's cap and synthetic rubber gasket may be used provided that the internal dimensions of the vessel are the same as those shown in Fig. 1. The internal dimensions of the pressure vessel are such that a nominal 25 by 150 mm (1 by 6 in.) test tube can be placed inside the pressure vessel.

5.2 *Test Tubes*, of borosilicate glass with nominal dimensions of 25 by 150 mm (1 by 6 in.). The internal dimensions shall be checked as acceptable by use of a copper foil strip (see 6.3). When 30 mL of liquid is added to the test tube with the copper foil strip in it, a minimum of 5 mm of liquid shall be above the top surface of the copper foil strip.

#### 5.3 Test Baths:

5.3.1 *General*—All test baths, whether liquid or solid block, shall be capable of maintaining the test temperature to within ± 1°C (2°F) of the required test temperature, for the entire duration of the test.

5.3.2 *Bath(s) Used for Submerging Pressure Vessel(s)*—Bath(s) shall be deep enough to submerge one or more pressure vessels (see 5.1) completely during the test. It shall be fitted with suitable supports to hold each pressure vessel in a vertical position when submerged.

5.3.3 *Bath(s) Used for Test Tubes*—Bath(s) shall be fitted with suitable supports to hold each test tube (see 5.2) in a vertical position to a depth of about 100 mm (4 in.) as measured from the bottom of the test tube to the bath surface. As a liquid bath medium, water and oil have been found satisfactory and controllable at the specified test temperature and duration required by the test procedure. Solid block baths shall meet the test temperature control, test duration, and immersion conditions required by the test procedure, and shall be checked for temperature measurement (heat transfer) for each product class by running tests on tubes filled with 30 mL of product plus a copper foil strip of the given nominal dimensions, plus a temperature sensor.

5.4 *Temperature Sensing and Monitoring Device (TSMD)*, capable of sensing and monitoring the desired test temperature in the bath to within an accuracy of ± 1°C (2°F) or better. The ASTM 12C (12F) (see Specification E1) or IP64C (64F) total immersion thermometer has been found suitable for use in the

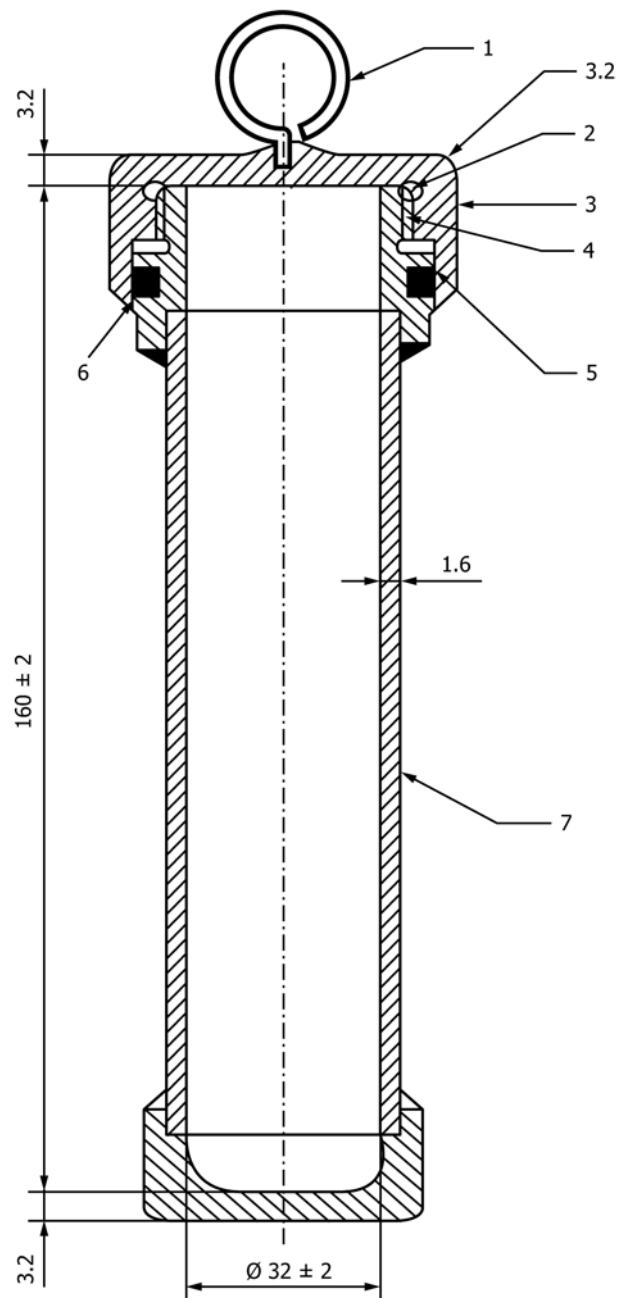

NOTE 1—Material: stainless steel; welded construction; maximum test gage pressure: 700 kPa

NOTE 2—Key:

- 1 Lifting eye
- 2 Wide groove for pressure relief
- 3 Knurled cap
- 4 Twelve threads per inch NF thread or equivalent
- 5 Camber inside cap to protect "O" ring when closing pressure vessel
- 6 Synthetic rubber "O" ring without free sulfur
- 7 Seamless tube

NOTE 3—Dimensions in millimetres.

NOTE 4—All dimensions without tolerance limits are nominal values.

FIG. 1 Pressure Vessel for the Copper Foil Strip Corrosion Test

test. If used, no more than 10 mm (0.4 in.) of the mercury should extend above the surface of the bath at the test temperature.

5.5 *Timing Device*, electronic or manual, capable of accurately measuring the test duration within the allowable tolerance.

5.6 *Forceps*, with either stainless steel or polytetrafluoroethylene (PTFE) tips, have been found suitable for use in handling the copper foil strips.

#### 5.7 *Optional Equipment:*

5.7.1 *Polishing Vise*, for holding the copper foil strip firmly without marring the edges while polishing. Any convenient type of holder (see X1.2) may be used, provided that the copper foil strip is held tightly and that the surface of the copper foil strip being polished is supported above the surface of the holder.

5.7.2 *Viewing Tubes*, flat glass test tubes, are convenient for protecting corroded copper foil strips for close inspection or storage (see X1.1 for the description of a flat-glass viewing tube). The viewing tube shall be of such dimensions as to allow the introduction of a copper foil strip (see 6.3) and made of glass free of striae or similar defects.

## 6. Reagents and Materials

6.1 *Wash Solvent*—Any volatile, less than 5 mg/kg sulfur hydrocarbon solvent may be used, provided that it shows no tarnish at all when tested for 3 h at 50°C (122°F). 2,2,4-trimethylpentane (isooctane) of minimum 99.75 % purity is the referee solvent and should be used in case of dispute. (**Warning**—Extremely flammable; see A2.1).

6.2 *Surface Preparation / Polishing Materials*—Scouring-pad made of polyester material that is free of detergents or spongy material, containing aluminum oxide as a scouring-aid. 3M Scotch Brite 86 (3M No. 05509),<sup>4,5</sup> approximately 400-grit, green-colored, heavy-duty, hand-pad, has been found suitable for use. Other commercially available 400-grit pads may be used, provided those are also made of polyester material, free of detergents or spongy material, containing aluminum oxide as a scouring-aid.

NOTE 1—3M Scotch Brite 86 pads are generally available in the form of 229 by 152 by 9.5 mm (9 by 6 by 3/8 in.) thick pads. For ease of handling and polishing, it is recommended that the pads be cut so that the dimensions of the scouring-pads are about 114 by 38 by 9.5 mm (4-1/2 by 1-1/2 by 3/8 in.).

6.3 *Copper Foil Strips*—Use copper foil strips approximately 12.5 mm (1/2 in.) wide, and 0.526 to 0.541 mm (0.0207 to 0.0213 in.) thick. Cut, straight and smooth, using a sharp tin-snip or any other metal-cutting device<sup>5,6</sup> approximately 75 mm (3 in.) long strips, from a 30.5 m (100 ft) roll of soft-temper, commercial grade Alloy 110, composed of 99.9 % copper, meeting Specification B152/B152M specifications.<sup>5,7</sup> Discard copper foil strip after each single use.

<sup>4</sup> The sole source of supply of the apparatus, Cat. No. 19-047-249, known to the committee at this time is Fisher Scientific Co., USA (www.fishersci.com).

<sup>5</sup> If you are aware of alternative suppliers, please provide this information to ASTM International Headquarters. Your comments will receive careful consideration at a meeting of the responsible technical committee,<sup>1</sup> which you may attend.

<sup>6</sup> The sole source of supply of the heavy-duty 6 in. shear, Part No. 82818, known to the committee at this time is Micro-mark, 340 Snyder Ave., Berkeley Heights, NJ 07922-1595, USA.

<sup>7</sup> The sole source of supply of the apparatus, Part No. 9053K21, known to the committee at this time is McMaster-Carr Supply Company, P.O. Box 4355, Chicago, IL 60680-4355, USA.

6.4 *Ashless Filter Paper or Disposable Gloves or Forceps (with either Stainless Steel or Polytetrafluoroethylene (PTFE)) Tips*, for use in protecting the copper foil strip from coming in contact with the individual during handling or polishing, or both.

## 7. Corrosion Standards

7.1 *ASTM Copper Strip Corrosion Standards*<sup>3</sup> consist of reproductions in color of typical test strips representing increasing degrees of tarnish and corrosion, the reproductions being encased for protection in plastic and made up in the form of a plaque.

7.1.1 Keep the plastic-encased ASTM Copper Strip Corrosion Standards protected from light to avoid the possibility of fading. Inspect for fading by comparing two different plaques, one of which has been carefully protected from light (for example, new plaque). Observe both sets in diffused daylight (or equivalent) first from a point directly above and then from an angle of 45°. If any evidence of fading is observed, particularly at the left-hand end of the plaque, it is suggested that the one that is the more faded with respect to the other be discarded.

7.1.1.1 Alternatively, place a suitably sized opaque strip (for example, 20 mm (3/4 in.) black electrical tape) across the top of the colored portion of the plaque when initially purchased. At intervals remove the opaque strip and observe. When there is any evidence of fading of the exposed portion, the standards shall be replaced.

7.1.1.2 These plaques are full-color reproductions of typical strips. They have been printed on aluminum sheets by a four-color process and are encased in plastic for protection. Directions for their use are given on the reverse side of each plaque.

7.1.2 If the surface of the plastic cover shows excessive scratching, it is suggested that the plaque be replaced.

## 8. Samples

8.1 In accordance with Practice D4057 or Practice D4177, or both, it is particularly important that all types of fuel samples that pass a low-tarnish strip classification, be collected in clean, dark glass bottles, plastic bottles, or other suitable containers that will not affect the corrosive properties of the fuel. Avoid the use of tin-plate containers for collection of samples, since experience has shown that they can contribute to the corrosiveness of the sample.

8.2 Fill the containers as completely as possible and close them immediately after taking the sample. Adequate headspace in the container is necessary to provide room for possible thermal expansion during transport. It is recommended that volatile samples be filled between 70 and 80 % of the container's capacity. Exercise care during sampling to protect the samples from exposure to direct sunlight or even diffused daylight. Carry out the test as soon as possible after receipt in the laboratory and immediately after opening the container.

8.3 If suspended water (that is, haze) is observed in the sample, dry by filtering a sufficient volume of sample through a medium rapid qualitative filter, into the prescribed clean, dry

test tube. Carry out this operation in a darkened room or under a light-protected shield.

8.3.1 Contact of the copper foil strip with water before, during, or after completion of the test run will cause staining, making it difficult to evaluate the copper foil strips.

## 9. Preparation of Test Strips

9.1 *Surface Preparation*—To prevent possible surface contamination during preparation, do not allow fingers to come in contact with the copper foil strip. Wear disposable gloves or hold the strip in the fingers protected with ashless filter paper.

9.1.1 Using a new/unused portion of a small strip of the 400-grit scouring-pad (see **Note 1**) first polish the ends, then the sides of the copper foil strip giving gentle, unidirectional strokes. Next, gently and unidirectionally, scour the long axis of the copper foil strip, carrying the stroke beyond the end of the strip before reversing the direction, until both surfaces demonstrate uniform asperities (roughness). Do not polish in a circular motion.

9.1.2 Alternatively, clamp the copper foil strip in a vise to facilitate uniform polishing.

9.1.3 Wash the copper foil strip with wash-solvent (see **6.1**), until it is free from metal dust and other foreign matter. Immediately immerse the prepared copper foil strip in either the test sample, or store it in the wash-solvent for future use.

## 10. Procedure

### 10.1 General:

10.1.1 There are a variety of test conditions, which are broadly specific to given classes of product, but within certain classes, more than one set of test conditions of time or temperature, or both, may apply. In general, aviation gasoline shall be tested in a pressure vessel at 100°C (212°F) and other high vapor pressure fuels, like natural gasoline or winter-grade gasoline at 40°C (104°F). Other liquid products shall be tested in a test tube at 50°C (122°F), 100°C (212°F) or even higher temperatures. The temperature conditions (but not the time durations) given are commonly used and are quoted in the ASTM specifications for these products tested by Test Method **D130** where such specifications exist. These are, however, guidelines only. In this procedure, test durations are defined as  $45 \pm 1$  min. Other conditions can also be used as and when required by specifications or by agreement between parties. The test conditions of time and temperature shall be recorded as part of the result (see **12.1**). (**Warning**—Some products, particularly natural gasoline, may have a much higher vapor pressure than would normally be characteristic of automotive or aviation gasolines. For this reason, extreme caution must be exercised to ensure that the pressure vessel used in this test method and containing natural gasoline or other products of high vapor pressure, is not placed in the 100°C (212°F) bath. Samples having vapor pressures in excess of 124 kPa (18 psi) may develop sufficient pressures at 100°C (212°F) to rupture the pressure vessel. For any sample having a vapor pressure above 124 kPa (18 psi), use Test Method **D1838**.)

10.2 *Pressure Vessel Procedure (PVP)*—For use with aviation gasoline, aviation turbine fuel, samples with initial boiling points (IBP) at or below test temperature, and highly volatile

samples, such as those with vapor pressures > 80 kPa at 37.8°C (100°F) (see **10.3.1.2**).

10.2.1 For aviation gasoline and aviation turbine fuel, place 30 mL of sample, completely clear and free of any suspended or entrained water (see **8.3**) into a clean and dry 25 by 150 mm (1 by 6 in.) test tube. Within 1 min after completing the surface preparation (polishing), slide the copper foil strip into the sample tube. Place the sample tube into the pressure vessel (see **Fig. 1**) and screw the lid on tightly. Note the time at which the assembly is placed in the bath. If more than one sample is to be analyzed, immerse each pressure vessel in the bath at  $100 \pm 1^\circ\text{C}$  ( $212 \pm 2^\circ\text{F}$ ), and note the time at which each specimen is placed in the bath. After  $45 \pm 1$  min in the bath, withdraw the pressure vessel and immerse it for a few minutes in cool water (tap water). Open the pressure vessel, withdraw the test tube and examine the copper foil strip as described in **10.4**. Discard the copper foil strip after use.

10.2.2 For natural gasoline, samples with initial boiling points (IBP) at or below test temperature, and highly volatile samples, such as those (for example, winter-grade gasoline) with vapor pressures > 80 kPa at 37.8°C (100°F), carry out the test exactly as described in **10.2.1**, but at 40°C (104°F) and for  $45 \pm 1$  min. Discard the copper foil strip after use. (See warning statement in **1.1**.)

10.3 *Test Tube Procedure (TTP)*—For use with samples with IBP above test temperature (for example, for use with most liquid or middle distillate products).

10.3.1 For diesel fuel, fuel oil, automotive gasoline, place 30 mL of sample, completely clear and free of any suspended or entrained water (see **8.3**) into a clean, dry 25 by 150 mm (1 by 6 in.) test tube, and, within 1 min after completing the surface preparation (polishing), slide the copper foil strip into the sample tube. Stopper the tube with a vented-cork having about 45 mm (1-3/4 in.) length of a 4 mm (1/8 in.) inside diameter (and about 6 mm (1/4 in. outside diameter)) plastic or glass tubing passing through it. For gasoline samples, place a plastic-cap with a pin-hole in it, over the plastic or glass tubing to reduce evaporation. Place the tube in a bath maintained at  $50 \pm 1^\circ\text{C}$  ( $122 \pm 2^\circ\text{F}$ ), and note the time at which the tube is placed in the bath. Protect the contents of the test tube from strong light during the test. If more than one sample is to be analyzed, immerse each test tube in the bath, and note the time at which each specimen is placed in the bath. After  $45 \pm 1$  min in the bath, withdraw the test tube and examine the copper foil strip as described in **10.4**. Discard the copper foil strip after use.

10.3.1.1 For tests on fuel oil and diesel fuel, using specifications other than Specifications **D396** and **D975**, a temperature of 100°C (212°F) for  $45 \pm 1$  min may be used as an alternative set of conditions.

10.3.1.2 Some automotive gasolines with vapor pressure above 80 kPa at 37.8°C (100°F) have exhibited evaporation losses in excess of 10 % of their volume. If such evaporation losses are apparent, it is recommended that the pressure vessel procedure (see **10.2**) be used.

10.3.2 For cleaners (for example, Stoddard solvent) and kerosine, carry out the test exactly as described in **10.3.1** but at  $100 \pm 1^\circ\text{C}$  ( $212 \pm 2^\circ\text{F}$ ). Discard the copper foil strip after use.



10.3.3 For lubricating oil, carry out the test exactly as described in 10.3.1, but the tests may be carried out for varying times and at elevated temperatures other than 100°C (212°F). For the sake of uniformity, it is suggested that even increments of 5°C (10°F), beginning with 150°C (302°F), be used. Discard the copper foil strip after use.

#### 10.4 Strip Examination:

10.4.1 Empty the contents of the test tube into a suitably-sized receiver. If a glass receiver is used, such as a 150 mL tall-form beaker, let the copper foil strip slide in gently so as to avoid breaking the glass. Immediately withdraw the copper foil strip with forceps and immerse in wash solvent. Withdraw the copper foil strip at once, dry and inspect for evidence of tarnishing or corrosion by comparison with the Copper Strip Corrosion Standards. Drying of the copper foil strip may be done by blotting with filter paper, air drying, or by other suitable means. Hold both the test copper foil strip and the standard strip plaque in such a manner that light reflected from them at an angle of approximately 45° will be observed.

10.4.2 In handling the test copper foil strip during the inspection and comparison, the danger of marking or staining can be avoided if it is inserted in a flat glass tube (see X1.1), which can be stoppered with absorbent cotton.

## 11. Interpretation of Results

11.1 Interpret the corrosiveness of the sample in accordance with one of the classifications of the ASTM Copper Strip Corrosion Standard as listed in Table 1.

**TABLE 1 Copper Foil Strip Classifications**

Classification	Designation	Description <sup>A</sup>
Freshly polished strip	...	<i>B</i>
1	slight tarnish	a. light orange, almost the same as freshly polished strip b. dark orange
2	moderate tarnish	a. claret red b. lavender c. multi-colored with lavender blue or silver, or both, overlaid on claret red d. silvery e. brassy or gold
3	dark tarnish	a. magenta overcast on brassy strip b. multicolored with red and green showing (peacock) but no gray
4	corrosion	a. transparent black, dark gray or brown with peacock green barely showing b. graphite or lusterless black c. glossy or jet black

<sup>A</sup> The ASTM Copper Strip Corrosion Standard is a colored reproduction of strips characteristic of these descriptions.

<sup>B</sup> The freshly polished strip is included in the series only as an indication of the appearance of a properly polished strip before a test run; it is not possible to duplicate this appearance after a test, even with a completely non-corrosive sample.

11.1.1 When a test strip is in the obvious transition state between that indicated by any two adjacent standard strips, rate the sample by the more tarnished standard strip. Should a strip appear to have a darker orange color than Standard Strip 1b, consider the observed strip as still belonging in Classification 1; however, if any evidence of red color is observed, the observed strip belongs in Classification 2.

11.1.2 A claret red strip in Classification 2 can be mistaken for a magenta overcast on a brassy strip in Classification 3 if the brassy underlay of the latter is completely masked by a magenta overtone. To distinguish, immerse the strip in wash solvent; the former will appear as a dark orange strip while the latter will not change.

11.1.3 To distinguish multi-colored strips in Classifications 2 and 3, place a test strip in a 25 by 150 mm (1 by 6 in.) test tube and bring to a temperature of 340 ± 30°C (644 ± 54°F) in 4 to 6 min with the tube lying on a hot plate. Adjust to temperature by observing a high distillation thermometer inserted into a second test tube. If the strip belongs to Classification 2, it will assume the color of a silver and then a gold strip. If in Classification 3, it will take on the appearance of a transparent black, and so forth, as described in Classification 4a.

11.1.4 Repeat the test if blemishes due to fingerprints are observed, or due to spots from any particles or water droplets that may have touched the test strip during the test.

11.1.5 Repeat the test also if the sharp edges along the flat faces of the strip appear to be in a classification higher than the greater portion of the strip; in this case, it is likely that the edges were burnished during preparation (polishing).

## 12. Report

12.1 Report the corrosiveness of the sample in accordance with one of the classifications listed in Table 1, as derived after comparison with the Copper Strip Corrosion Standards. State the test method (TM) designation, the test procedure followed (pressure vessel procedure (PVP) or test tube procedure (TTP)), duration of the test, and the test temperature in the following format:

Corrosion, copper foil strip, Classification Zp by TM, PVP or TTP,  
Xm at Y°C

where:

Xm = test duration, min,

Y = test temperature, °C,

Z = classification category (that is, 1, 2, 3, or 4), and

p = classification description for the corresponding Z (for example, a, b, c, d or e).

## 13. Precision and Bias

13.1 In the case of pass/fail data, no generally accepted method for determining precision or bias is currently available.

13.2 *Relative Bias*<sup>8</sup>—During the development of this test method, a comparison study was performed between this method and Test Method D130. The comparison study involved six laboratories that analyzed a variety of sample types

<sup>8</sup> Supporting data (the comparison study) have been filed at ASTM International Headquarters and may be obtained by requesting Research Report RR:D02-1562.

available in their laboratory. A total of 46 samples, covering the copper corrosion standard rating range from 1a to 3b (see **Table 1**), were evaluated. Sample types evaluated in the study include naphtha, gasoline, low and high sulfur diesel, JP-5, aviation turbine fuel, No. 2 fuel oil, gas oil, and hexane (solvent). Copper corrosion standard ratings determined by both methods matched exactly in all cases, with the exception of one sample,

where the Test Method **D130** analysis resulted in a rating of 1b as compared to 1a by this test method.

#### **14. Keywords**

14.1 automotive gasoline; aviation gasoline; aviation turbine fuel; copper corrosion; copper foil strip; corrosiveness to copper; natural gasoline

## **ANNEXES**

### **(Mandatory Information)**

#### **A1. COPPER QUALITY**

##### **A1.1 Copper Quality**

A1.1.1 Soft-temper, commercial-grade Alloy 110, composed of 99.9 % copper. Meets Specification **B152/B152M** specifications.

#### **A2. WARNING STATEMENTS**

##### **A2.1 Isooctane**

A2.1 Harmful if inhaled. Vapors may cause flash fire.

Keep away from heat, sparks, and open flame.

Keep container closed.

Use with adequate ventilation.

Avoid buildup of vapors and eliminate all sources of ignition, especially non-explosion-proof electrical apparatus and heaters.

Avoid prolonged breathing of vapor or spray mist.

Avoid prolonged or repeated skin contact.

**A2.2 Aviation Turbine Fuel** (Jet A or A-1 see Specification **D1655**, or Jet B, see Specification **D6615**)

A2.2 Keep away from heat, sparks, and open flames.

Keep container closed.

Use with adequate ventilation.

Avoid breathing vapor or spray mist.

Avoid prolonged or repeated contact with skin.

##### **A2.3 Gasoline (Leaded or Unleaded)**

A2.3 Keep away from heat, sparks, and open flame.

Keep container closed.

Use with adequate ventilation.

Avoid build-up of vapors and eliminate all sources of ignition, especially non-explosion-proof electrical apparatus and heaters.

Avoid prolonged breathing of vapor or spray mist.

Avoid prolonged or repeated skin contact.

##### **A2.4 Kerosine**

A2.4 Keep away from heat, sparks, and open flame.

Keep container closed.

Use with adequate ventilation.

Avoid prolonged breathing of vapor or spray mist.

Avoid prolonged or repeated skin contact.

##### **A2.5 Stoddard Solvent**

A2.5 Keep away from heat, sparks, and open flame.

Keep container closed.

Use with adequate ventilation.

Avoid prolonged breathing of vapor or spray mist.

Avoid prolonged or repeated skin contact.

APPENDIX

(Nonmandatory Information)

X1. OPTIONAL USEFUL EQUIPMENT

X1.1 Viewing Tube

X1.1.1 A useful flat glass test tube for holding tarnished copper foil strips for inspection or for storage for later inspection is illustrated and dimensioned in Fig. X1.1.

X1.2 Strip Vise

X1.2.1 A useful and convenient vise for holding up to four copper foil strips during final polishing is illustrated and dimensioned in Fig. X1.2.

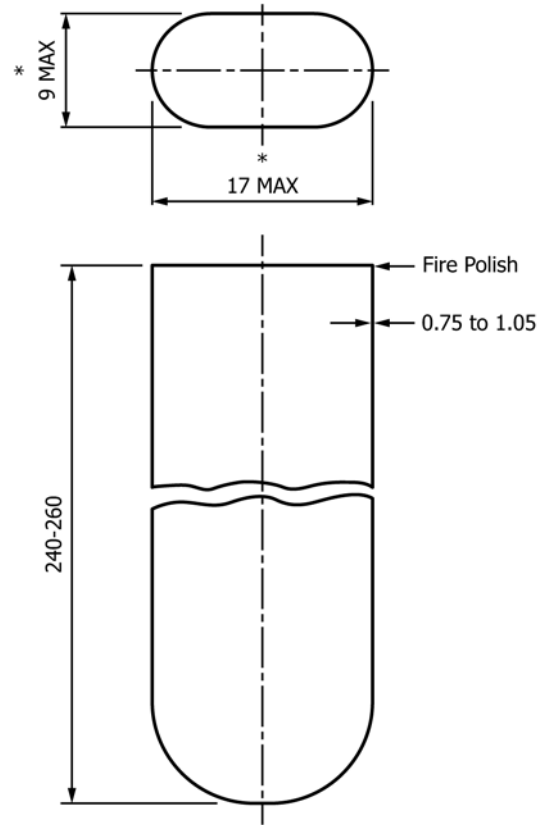

NOTE 1—Dimensions are in millimetres.

NOTE 2—The dimensions are the minimum dimensions that shall allow the introduction of a copper foil strip 75 mm (3 in.) long by 12.5 mm (½ in.) wide by 0.541 mm (0.0213 in.) thick.

NOTE 3—The tube shall be free of striae or similar defects.

FIG. X1.1 Flat Glass Viewing Test Tube

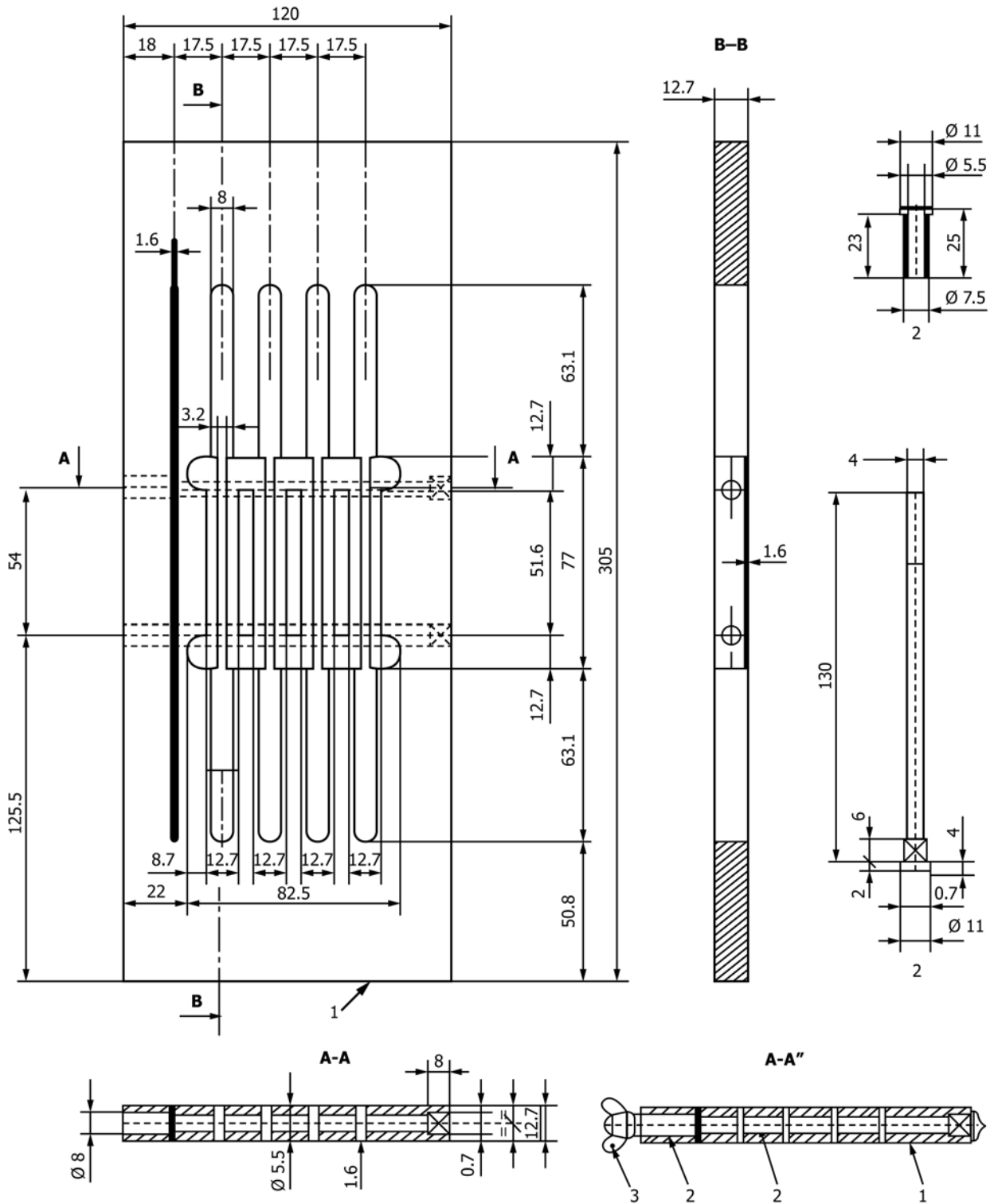

NOTE 1—Key:

1 Material: Plastic

2 Material: Brass

3 Wing nut

4  $\text{\O} 5$  mm metric thread or equivalent

NOTE 2—Dimensions are in millimetres.

FIG. X1.2 Multistrip Vise



*ASTM International takes no position respecting the validity of any patent rights asserted in connection with any item mentioned in this standard. Users of this standard are expressly advised that determination of the validity of any such patent rights, and the risk of infringement of such rights, are entirely their own responsibility.*

*This standard is subject to revision at any time by the responsible technical committee and must be reviewed every five years and if not revised, either reapproved or withdrawn. Your comments are invited either for revision of this standard or for additional standards and should be addressed to ASTM International Headquarters. Your comments will receive careful consideration at a meeting of the responsible technical committee, which you may attend. If you feel that your comments have not received a fair hearing you should make your views known to the ASTM Committee on Standards, at the address shown below.*

*This standard is copyrighted by ASTM International, 100 Barr Harbor Drive, PO Box C700, West Conshohocken, PA 19428-2959, United States. Individual reprints (single or multiple copies) of this standard may be obtained by contacting ASTM at the above address or at 610-832-9585 (phone), 610-832-9555 (fax), or [service@astm.org](mailto:service@astm.org) (e-mail); or through the ASTM website ([www.astm.org](http://www.astm.org)). Permission rights to photocopy the standard may also be secured from the Copyright Clearance Center, 222 Rosewood Drive, Danvers, MA 01923, Tel: (978) 646-2600; <http://www.copyright.com/>*