



Standard Test Methods for Laboratory Compaction Characteristics of Soil Using Standard Effort (12 400 ft-lbf/ft³ (600 kN-m/m³))¹

This standard is issued under the fixed designation D698; the number immediately following the designation indicates the year of original adoption or, in the case of revision, the year of last revision. A number in parentheses indicates the year of last reapproval. A superscript epsilon (ϵ) indicates an editorial change since the last revision or reapproval.

This standard has been approved for use by agencies of the U.S. Department of Defense.

^{ε1} NOTE—Editorial corrections made throughout in January 2014.

^{ε2} NOTE—Editorially corrected variable for [Eq A1.2](#) in July 2015.

1. Scope*

1.1 These test methods cover laboratory compaction methods used to determine the relationship between molding water content and dry unit weight of soils (compaction curve) compacted in a 4 or 6-in. (101.6 or 152.4-mm) diameter mold with a 5.50-lbf (24.5-N) rammer dropped from a height of 12.0 in. (305 mm) producing a compactive effort of 12 400 ft-lbf/ft³ (600 kN-m/m³).

NOTE 1—The equipment and procedures are similar as those proposed by R. R. Proctor (*Engineering News Record*—September 7, 1933) with this one major exception: his rammer blows were applied as “12 inch firm strokes” instead of free fall, producing variable compactive effort depending on the operator, but probably in the range 15 000 to 25 000 ft-lbf/ft³ (700 to 1200 kN-m/m³). The standard effort test (see [3.1.4](#)) is sometimes referred to as the Proctor Test.

1.1.1 Soils and soil-aggregate mixtures are to be regarded as natural occurring fine- or coarse-grained soils, or composites or mixtures of natural soils, or mixtures of natural and processed soils or aggregates such as gravel or crushed rock. Hereafter referred to as either soil or material.

1.2 These test methods apply only to soils (materials) that have 30 % or less by mass of particles retained on the $\frac{3}{4}$ -in. (19.0-mm) sieve and have not been previously compacted in the laboratory; that is, do not reuse compacted soil.

1.2.1 For relationships between unit weights and molding water contents of soils with 30 % or less by mass of material retained on the $\frac{3}{4}$ -in. (19.0-mm) sieve to unit weights and molding water contents of the fraction passing $\frac{3}{4}$ -in. (19.0-mm) sieve, see Practice [D4718](#).

1.3 Three alternative methods are provided. The method used shall be as indicated in the specification for the material

being tested. If no method is specified, the choice should be based on the material gradation.

1.3.1 *Method A:*

1.3.1.1 *Mold*—4-in. (101.6-mm) diameter.

1.3.1.2 *Material*—Passing No. 4 (4.75-mm) sieve.

1.3.1.3 *Layers*—Three.

1.3.1.4 *Blows per Layer*—25.

1.3.1.5 *Usage*—May be used if 25 % or less (see [1.4](#)) by mass of the material is retained on the No. 4 (4.75-mm) sieve.

1.3.1.6 *Other Usage*—If this gradation requirement cannot be met, then Method C may be used.

1.3.2 *Method B:*

1.3.2.1 *Mold*—4-in. (101.6-mm) diameter.

1.3.2.2 *Material*—Passing $\frac{3}{8}$ -in. (9.5-mm) sieve.

1.3.2.3 *Layers*—Three.

1.3.2.4 *Blows per Layer*—25.

1.3.2.5 *Usage*—May be used if 25 % or less (see [1.4](#)) by mass of the material is retained on the $\frac{3}{8}$ -in. (9.5-mm) sieve.

1.3.2.6 *Other Usage*—If this gradation requirement cannot be met, then Method C may be used.

1.3.3 *Method C:*

1.3.3.1 *Mold*—6-in. (152.4-mm) diameter.

1.3.3.2 *Material*—Passing $\frac{3}{4}$ -in. (19.0-mm) sieve.

1.3.3.3 *Layers*—Three.

1.3.3.4 *Blows per Layer*—56.

1.3.3.5 *Usage*—May be used if 30 % or less (see [1.4](#)) by mass of the material is retained on the $\frac{3}{4}$ -in. (19.0-mm) sieve.

1.3.4 The 6-in. (152.4-mm) diameter mold shall not be used with Method A or B.

NOTE 2—Results have been found to vary slightly when a material is tested at the same compactive effort in different size molds, with the smaller mold size typically yielding larger values of density/unit weight ([1](#), pp. 21+).²

1.4 If the test specimen contains more than 5 % by mass of oversize fraction (coarse fraction) and the material will not be

¹ These Test Methods are under the jurisdiction of ASTM Committee D18 on Soil and Rock and are the direct responsibility of Subcommittee D18.03 on Texture, Plasticity and Density Characteristics of Soils.

Current edition approved May 1, 2012. Published June 2012. Originally approved in 1942. Last previous edition approved in 2000 as D698 – 07^{ε1}. DOI: 10.1520/D0698-12E01.

² The boldface numbers in parentheses refer to the list of references at the end of this standard.

*A Summary of Changes section appears at the end of this standard

included in the test, corrections must be made to the unit mass and molding water content of the specimen or to the appropriate field-in-place density test specimen using Practice [D4718](#).

1.5 This test method will generally produce a well-defined maximum dry unit weight for non-free draining soils. If this test method is used for free-draining soils the maximum unit weight may not be well defined, and can be less than obtained using Test Methods [D4253](#).

1.6 All observed and calculated values shall conform to the guidelines for significant digits and rounding established in Practice [D6026](#), unless superseded by this standard.

1.6.1 For purposes of comparing measured or calculated value(s) with specified limits, the measured or calculated value(s) shall be rounded to the nearest decimal or significant digits in the specified limits.

1.6.2 The procedures used to specify how data are collected/recorded or calculated, in this standard are regarded as the industry standard. In addition, they are representative of the significant digits that generally should be retained. The procedures used do not consider material variation, purpose for obtaining the data, special purpose studies, or any considerations for the user's objectives; and it is common practice to increase or reduce significant digits of reported data to be commensurate with these considerations. It is beyond the scope of this standard to consider significant digits used in analytical methods for engineering design.

1.7 The values in inch-pound units are to be regarded as the standard. The values stated in SI units are provided for information only, except for units of mass. The units for mass are given in SI units only, g or kg.

1.7.1 It is common practice in the engineering profession to concurrently use pounds to represent both a unit of mass (lbm) and a force (lbf). This implicitly combines two separate systems of units; that is, the absolute system and the gravitational system. It is scientifically undesirable to combine the use of two separate sets of inch-pound units within a single standard. This standard has been written using the gravitational system of units when dealing with the inch-pound system. In this system, the pound (lbf) represents a unit of force (weight). However, the use of balances or scales recording pounds of mass (lbm) or the recording of density in lbm/ft³ shall not be regarded as a nonconformance with this standard.

1.8 *This standard does not purport to address all of the safety concerns, if any, associated with its use. It is the responsibility of the user of this standard to establish appropriate safety and health practices and determine the applicability of regulatory limitations prior to use.*

2. Referenced Documents

2.1 ASTM Standards:³

[C127 Test Method for Relative Density \(Specific Gravity\) and Absorption of Coarse Aggregate](#)

[C136 Test Method for Sieve Analysis of Fine and Coarse Aggregates](#)
[D653 Terminology Relating to Soil, Rock, and Contained Fluids](#)
[D854 Test Methods for Specific Gravity of Soil Solids by Water Pycnometer](#)
[D2168 Practices for Calibration of Laboratory Mechanical-Rammer Soil Compactors](#)
[D2216 Test Methods for Laboratory Determination of Water \(Moisture\) Content of Soil and Rock by Mass](#)
[D2487 Practice for Classification of Soils for Engineering Purposes \(Unified Soil Classification System\)](#)
[D2488 Practice for Description and Identification of Soils \(Visual-Manual Procedure\)](#)
[D3740 Practice for Minimum Requirements for Agencies Engaged in Testing and/or Inspection of Soil and Rock as Used in Engineering Design and Construction](#)
[D4253 Test Methods for Maximum Index Density and Unit Weight of Soils Using a Vibratory Table](#)
[D4718 Practice for Correction of Unit Weight and Water Content for Soils Containing Oversize Particles](#)
[D4753 Guide for Evaluating, Selecting, and Specifying Balances and Standard Masses for Use in Soil, Rock, and Construction Materials Testing](#)
[D4914 Test Methods for Density and Unit Weight of Soil and Rock in Place by the Sand Replacement Method in a Test Pit](#)
[D5030 Test Method for Density of Soil and Rock in Place by the Water Replacement Method in a Test Pit](#)
[D6026 Practice for Using Significant Digits in Geotechnical Data](#)
[D6913 Test Methods for Particle-Size Distribution \(Gradation\) of Soils Using Sieve Analysis](#)
[E11 Specification for Woven Wire Test Sieve Cloth and Test Sieves](#)
[E177 Practice for Use of the Terms Precision and Bias in ASTM Test Methods](#)
[E691 Practice for Conducting an Interlaboratory Study to Determine the Precision of a Test Method](#)
[IEEE/ASTM SI 10 Standard for Use of the International System of Units \(SI\): the Modern Metric System](#)

3. Terminology

3.1 Definitions:

3.1.1 See Terminology [D653](#) for general definitions.

3.1.2 *molding water content, n*—the adjusted water content of a soil (material) that will be compacted/reconstituted.

3.1.3 *standard effort*—in compaction testing, the term for the 12 400 ft-lbf/ft³ (600 kN-m/m³) compactive effort applied by the equipment and methods of this test.

3.1.4 *standard maximum dry unit weight, $\gamma_{d,max}$ in lbf/ft³ (kN/m³)*—in compaction testing, the maximum value defined by the compaction curve for a compaction test using standard effort.

3.1.5 *standard optimum water content, w_{opt} in %*—in compaction testing, the molding water content at which a soil can be compacted to the maximum dry unit weight using standard compactive effort.

³ For referenced ASTM standards, visit the ASTM website, www.astm.org, or contact ASTM Customer Service at service@astm.org. For *Annual Book of ASTM Standards* volume information, refer to the standard's Document Summary page on the ASTM website.

3.2 Definitions of Terms Specific to This Standard:

3.2.1 *oversize fraction (coarse fraction), P_C in %*—the portion of total specimen not used in performing the compaction test; it may be the portion of total specimen retained on the No. 4 (4.75-mm) sieve in Method A, $\frac{3}{8}$ -in. (9.5-mm) sieve in Method B, or $\frac{3}{4}$ -in. (19.0-mm) sieve in Method C.

3.2.2 *test fraction (finer fraction), P_F in %*—the portion of the total specimen used in performing the compaction test; it is the fraction passing the No. 4 (4.75-mm) sieve in Method A, passing the $\frac{3}{8}$ -in. (9.5-mm) sieve in Method B, or passing the $\frac{3}{4}$ -in. (19.0-mm) sieve in Method C.

4. Summary of Test Method

4.1 A soil at a selected molding water content is placed in three layers into a mold of given dimensions, with each layer compacted by 25 or 56 blows of a 5.50-lbf (24.47-N) rammer dropped from a distance of 12.00 in. (304.8 mm), subjecting the soil to a total compactive effort of about 12 400 ft-lbf/ft³ (600 kN-m/m³). The resulting dry unit weight is determined. The procedure is repeated for a sufficient number of molding water contents to establish a relationship between the dry unit weight and the molding water content for the soil. This data, when plotted, represents a curvilinear relationship known as the compaction curve. The values of optimum water content and standard maximum dry unit weight are determined from the compaction curve.

5. Significance and Use

5.1 Soil placed as engineering fill (embankments, foundation pads, road bases) is compacted to a dense state to obtain satisfactory engineering properties such as, shear strength, compressibility, or permeability. In addition, foundation soils are often compacted to improve their engineering properties. Laboratory compaction tests provide the basis for determining the percent compaction and molding water content needed to achieve the required engineering properties, and for controlling construction to assure that the required compaction and water contents are achieved.

5.2 During design of an engineered fill, shear, consolidation, permeability, or other tests require preparation of test specimens by compacting at some molding water content to some unit weight. It is common practice to first determine the optimum water content (w_{opt}) and maximum dry unit weight ($\gamma_{d,max}$) by means of a compaction test. Test specimens are compacted at a selected molding water content (w), either wet or dry of optimum (w_{opt}) or at optimum (w_{opt}), and at a selected dry unit weight related to a percentage of maximum dry unit weight ($\gamma_{d,max}$). The selection of molding water content (w), either wet or dry of optimum (w_{opt}) or at optimum (w_{opt}) and the dry unit weight ($\gamma_{d,max}$) may be based on past experience, or a range of values may be investigated to determine the necessary percent of compaction.

5.3 Experience indicates that the methods outlined in 5.2 or the construction control aspects discussed in 5.1 are extremely difficult to implement or yield erroneous results when dealing with certain soils. 5.3.1 – 5.3.3 describe typical problem soils, the problems encountered when dealing with such soils and possible solutions for these problems.

5.3.1 *Oversize Fraction*—Soils containing more than 30 % oversize fraction (material retained on the $\frac{3}{4}$ -in. (19-mm) sieve) are a problem. For such soils, there is no ASTM test method to control their compaction and very few laboratories are equipped to determine the laboratory maximum unit weight (density) of such soils (USDI Bureau of Reclamation, Denver, CO and U.S. Army Corps of Engineers, Vicksburg, MS). Although Test Methods D4914 and D5030 determine the “field” dry unit weight of such soils, they are difficult and expensive to perform.

5.3.1.1 One method to design and control the compaction of such soils is to use a test fill to determine the required degree of compaction and the method to obtain that compaction, followed by use of a method specification to control the compaction. Components of a method specification typically contain the type and size of compaction equipment to be used, the lift thickness, acceptable range in molding water content, and the number of passes.

NOTE 3—Success in executing the compaction control of an earthwork project, especially when a method specification is used, is highly dependent upon the quality and experience of the contractor and inspector.

5.3.1.2 Another method is to apply the use of density correction factors developed by the USDI Bureau of Reclamation (2, 3) and U.S. Corps of Engineers (4). These correction factors may be applied for soils containing up to about 50 to 70 % oversize fraction. Each agency uses a different term for these density correction factors. The USDI Bureau of Reclamation uses D ratio (or D -VALUE), while the U.S. Corps of Engineers uses Density Interference Coefficient (I_c).

5.3.1.3 The use of the replacement technique (Test Method D698–78, Method D), in which the oversize fraction is replaced with a finer fraction, is inappropriate to determine the maximum dry unit weight, $\gamma_{d,max}$, of soils containing oversize fractions (4).

5.3.2 *Degradation*—Soils containing particles that degrade during compaction are a problem, especially when more degradation occurs during laboratory compaction than field compaction, as is typical. Degradation typically occurs during the compaction of a granular-residual soil or aggregate. When degradation occurs, the maximum dry-unit weight increases (1, p. 73) so that the laboratory maximum value is not representative of field conditions. Often, in these cases, the maximum dry unit weight is impossible to achieve in the field.

5.3.2.1 Again, for soils subject to degradation, the use of test fills and method specifications may help. Use of replacement techniques is not correct.

5.3.3 *Gap Graded*—Gap-graded soils (soils containing many large particles with limited small particles) are a problem because the compacted soil will have larger voids than usual. To handle these large voids, standard test methods (laboratory or field) typically have to be modified using engineering judgement.

NOTE 4—The quality of the result produced by this standard is dependent on the competence of the personnel performing it, and the suitability of the equipment and facilities used. Agencies that meet the criteria of Practice D3740 are generally considered capable of competent and objective testing/sampling/inspection, and the like. Users of this standard are cautioned that compliance with Practice D3740 does not in itself assure reliable results. Reliable results depend on many factors;

Practice D3740 provides a means of evaluating some of those factors.

6. Apparatus

6.1 *Mold Assembly*—The molds shall be cylindrical in shape, made of rigid metal and be within the capacity and dimensions indicated in 6.1.1 or 6.1.2 and Figs. 1 and 2. See also Table 1. The walls of the mold may be solid, split, or tapered. The “split” type may consist of two half-round sections, or a section of pipe split along one element, which can be securely locked together to form a cylinder meeting the requirements of this section. The “tapered” type shall have an internal diameter taper that is uniform and not more than 0.200 in./ft (16.7 mm/m) of mold height. Each mold shall have a base plate and an extension collar assembly, both made of rigid metal and constructed so they can be securely attached and easily detached from the mold. The extension collar assembly shall have a height extending above the top of the mold of at least 2.0 in. (51 mm) which may include an upper section that flares out to form a funnel, provided there is at least a 0.75 in. (19 mm) straight cylindrical section beneath it. The extension collar shall align with the inside of the mold. The bottom of the base plate and bottom of the centrally recessed area that accepts the cylindrical mold shall be planar within ±0.005 in. (±0.1 mm).

6.1.1 *Mold, 4 in.*—A mold having a 4.000 ± 0.016 -in. (101.6 ± 0.4 -mm) average inside diameter, a height of 4.584 ± 0.018 in. (116.4 ± 0.5 mm) and a volume of 0.0333 ± 0.0005 ft³ (943.0 ± 14 cm³). A mold assembly having the minimum required features is shown in Fig. 1.

6.1.2 *Mold, 6 in.*—A mold having a 6.000 ± 0.026 -in. (152.4 ± 0.7 -mm) average inside diameter, a height of 4.584 ± 0.018 in. (116.4 ± 0.5 mm), and a volume of 0.0750 ± 0.0009 ft³ (2124 ± 25 cm³). A mold assembly having the minimum required features is shown in Fig. 2.

6.2 *Rammer*—A rammer, either manually operated as described further in 6.2.1 or mechanically operated as described in 6.2.2. The rammer shall fall freely through a distance of 12.00 ± 0.05 in. (304.8 ± 1 mm) from the surface of the specimen. The weight of the rammer shall be 5.50 ± 0.02 lbf (24.47 ± 0.09 N, or mass of 2.495 ± 0.009 kg), except that the weight of the mechanical rammers may be adjusted as described in Practices D2168; see Note 5. The striking face of the rammer shall be planar and circular, except as noted in 6.2.2.1,

As an option to the full length stud, a 2 1/2" x 3/8" stud may be used. Then as an alternative construction, the collar may be held down with a slotted bracket attached to the collar and a pin in the mold.

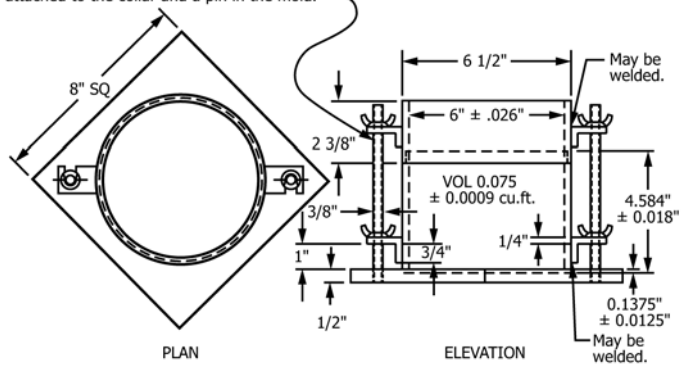

FIG. 2 6.0-in. Cylindrical Mold

TABLE 1 Metric Equivalents for Figs. 1 and 2

in.	mm
0.016	0.41
0.026	0.66
0.032	0.81
0.028	0.71
1/2	12.70
2 1/2	63.50
2 5/8	66.70
4	101.60
4 1/2	114.30
4.584	116.43
4 3/4	120.60
6	152.40
6 1/2	165.10
6 5/8	168.30
6 3/4	171.40
8 1/4	209.60
ft ³	cm ³
1/50 (0.0333)	943
0.0005	14
(0.0750)	2,124
0.0011	31

with a diameter when new of 2.000 ± 0.005 in. (50.80 ± 0.13 mm). The rammer shall be replaced if the striking face becomes worn or bellied to the extent that the diameter exceeds 2.000 ± 0.01 in. (50.80 ± 0.25 mm).

NOTE 5—It is a common and acceptable practice to determine the weight of the rammer using either a kilogram or pound balance and assume 1 lbf is equivalent to 0.4536 kg, 1 lbf is equivalent to 1 lbm, or 1 N is equivalent to 0.2248 lbf or 0.1020 kg.

6.2.1 *Manual Rammer*—The rammer shall be equipped with a guide sleeve that has sufficient clearance that the free fall of the rammer shaft and head is not restricted. The guide sleeve shall have at least four vent holes at each end (eight holes total) located with centers $3/4 \pm 1/16$ in. (19 ± 2 mm) from each end and spaced 90 degrees apart. The minimum diameter of the vent holes shall be $3/8$ in. (9.5 mm). Additional holes or slots may be incorporated in the guide sleeve.

6.2.2 *Mechanical Rammer-Circular Face*—The rammer shall operate mechanically in such a manner as to provide uniform and complete coverage of the specimen surface. There shall be 0.10 ± 0.03 -in. (2.5 ± 0.8 -mm) clearance between the rammer and the inside surface of the mold at its smallest

As an option to the full length stud, a 2 1/2" x 3/8" stud may be used. Then as an alternative construction, the collar may be held down with a slotted bracket attached to the collar and a pin in the mold.

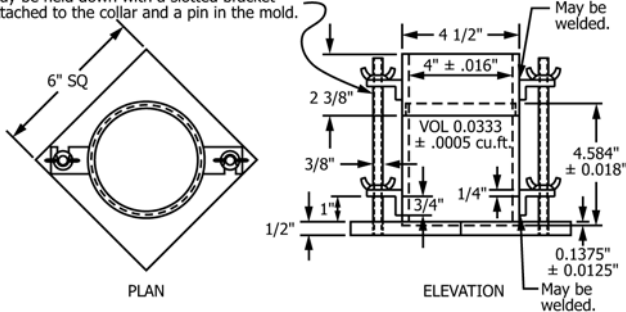

FIG. 1 4.0-in. Cylindrical Mold

diameter. The mechanical rammer shall meet the standardization/calibration requirements of Practices D2168. The mechanical rammer shall be equipped with a positive mechanical means to support the rammer when not in operation.

6.2.2.1 *Mechanical Rammer-Sector Face*—The sector face can be used with the 6-in. (152.4-mm) mold, as an alternative to the circular face mechanical rammer described in 6.2.2. The striking face shall have the shape of a sector of a circle of radius equal to 2.90 ± 0.02 in. (73.7 ± 0.5 mm) and an area about the same as the circular face, see 6.2. The rammer shall operate in such a manner that the vertex of the sector is positioned at the center of the specimen and follow the compaction pattern given in Fig. 3b.

6.3 *Sample Extruder (optional)*—A jack, with frame or other device adapted for the purpose of extruding compacted specimens from the mold.

6.4 *Balance*—A Class GP5 balance meeting the requirements of Guide D4753 for a balance of 1-g readability. If the water content of the compacted specimens is determined using a representative portion of the specimen, rather than the whole specimen, and if the representative portion is less than 1000 g, a Class GP2 balance having a 0.1-g readability is needed in order to comply with Test Methods D2216 requirements for determining water content to 0.1 %.

NOTE 6—Use of a balance having an equivalent capacity and a readability of 0.002 lbm as an alternative to a class GP5 balance should not be regarded as nonconformance to this standard.

6.5 *Drying Oven*—Thermostatically controlled oven, capable of maintaining a uniform temperature of $230 \pm 9^\circ\text{F}$ ($110 \pm 5^\circ\text{C}$) throughout the drying chamber. These requirements typically require the use of a forced-draft type oven. Preferably the oven should be vented outside the building.

6.6 *Straightedge*—A stiff metal straightedge of any convenient length but not less than 10 in. (250 mm). The total length of the straightedge shall be machined straight to a tolerance of ± 0.005 in. (± 0.1 mm). The scraping edge shall be beveled if it is thicker than $\frac{1}{8}$ in. (3 mm).

6.7 *Sieves*— $\frac{3}{4}$ in. (19.0 mm), $\frac{3}{8}$ in. (9.5 mm), and No. 4 (4.75 mm), conforming to the requirements of Specification E11.

6.8 *Mixing Tools*—Miscellaneous tools such as mixing pan, spoon, trowel, spatula, spraying device (to add water evenly),

and (preferably, but optional) suitable mechanical device for thoroughly mixing the subspecimen of soil with increments of water.

7. Standardization/Calibration

7.1 Perform standardizations before initial use, after repairs or other occurrences that might affect the test results, at intervals not exceeding 1,000 test specimens, or annually, whichever occurs first, for the following apparatus:

7.1.1 *Balance*—Evaluate in accordance with Guide D4753.

7.1.2 *Molds*—Determine the volume as described in Annex A1.

7.1.3 *Manual Rammer*—Verify the free fall distance, rammer weight, and rammer face are in accordance with 6.2. Verify the guide sleeve requirements are in accordance with 6.2.1.

7.1.4 *Mechanical Rammer*—Verify and adjust if necessary that the mechanical rammer is in accordance with Practices D2168. In addition, the clearance between the rammer and the inside surface of the mold shall be verified in accordance with 6.2.2.

8. Test Specimen

8.1 The minimum specimen (test fraction) mass for Methods A and B is about 16 kg, and for Method C is about 29 kg of dry soil. Therefore, the field sample should have a moist mass of at least 23 kg and 45 kg, respectively. Greater masses would be required if the oversize fraction is large (see 10.2 or 10.3) or an additional molding water content is taken during compaction of each point (see 10.4.2.1).

8.2 If gradation data is not available, estimate the percentage of material (by mass) retained on the No. 4 (4.75-mm), $\frac{3}{8}$ -in. (9.5-mm), or $\frac{3}{4}$ -in. (19.0-mm) sieve as appropriate for selecting Method A, B, or C, respectively. If it appears the percentage retained of interest is close to the allowable value for a given Method (A, B, or C), then either:

8.2.1 Select a Method that allows a higher percentage retained (B or C).

8.2.2 Using the Method of interest, process the specimen in accordance with 10.2 or 10.3, this determines the percentage retained for that method. If acceptable, proceed, if not go to the next Method (B or C).

8.2.3 Determine percentage retained values by using a representative portion from the total sample, and performing a simplified or complete gradation analysis using the sieve(s) of

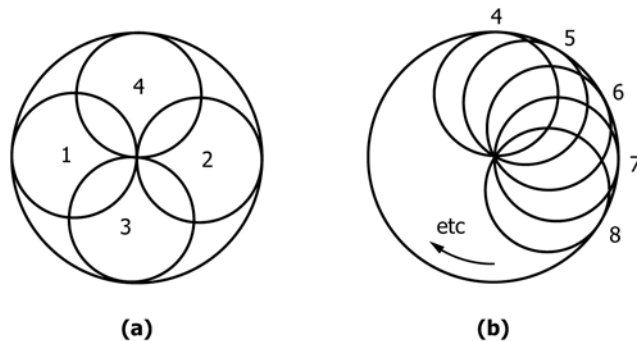

FIG. 3 Rammer Pattern for Compaction in 4 in. (101.6 mm) Mold

interest and Test Methods **D6913** or **C136**. It is only necessary to calculate the retained percentage(s) for the sieve or sieves for which information is desired.

9. Preparation of Apparatus

9.1 Select the proper compaction mold(s), collar, and base plate in accordance with the Method (A, B, or C) being used. Check that its volume is known and determined with or without base plate, free of nicks or dents, and will fit together properly.

NOTE 7—Mass requirements are given in **10.4**.

9.2 Check that the manual or mechanical rammer assembly is in good working condition and that parts are not loose or worn. Make any necessary adjustments or repairs. If adjustments or repairs are made, the rammer must be re-standardized.

10. Procedure

10.1 Soils:

10.1.1 Do not reuse soil that has been previously compacted in the laboratory. The reuse of previously compacted soil yields a significantly greater maximum dry unit weight (**1**, p. 31).

10.1.2 When using this test method for soils containing hydrated halloysite, or in which past experience indicates that results will be altered by air-drying, use the moist preparation method (see **10.2**). In referee testing, each laboratory has to use the same method of preparation, either moist (preferred) or air-dried.

10.1.3 Prepare the soil specimens for testing in accordance with **10.2** (preferred) or with **10.3**.

10.2 *Moist Preparation Method (preferred)*—Without previously drying the sample/specimen, process it over a No. 4 (4.75-mm), $\frac{3}{8}$ -in. (9.5-mm), or $\frac{3}{4}$ -in. (19.0-mm) sieve, depending on the Method (A, B, or C) being used or required as covered in **8.2**. For additional processing details, see Test Methods **D6913**. Determine and record the mass of both the retained and passing portions (oversize fraction and test fraction, respectively) to the nearest g. Oven dry the oversize fraction and determine and record its dry mass to the nearest g. If it appears more than 0.5 % of the total dry mass of the specimen is adhering to the oversize fraction, wash that fraction. Then determine and record its oven dry mass to the nearest g. Determine and record the water content of the processed soil (test fraction). Using that water content, determine and record the oven dry mass of the test fraction to the nearest g. Based on these oven dry masses, the percent oversize fraction, P_C , and test fraction, P_F , shall be determined and recorded, unless a gradation analysis has already been performed, see Section **11** on Calculations.

10.2.1 From the test fraction, select and prepare at least four (preferably five) subspecimens having molding water contents such that they bracket the estimated optimum water content. A subspecimen having a molding water content close to optimum should be prepared first by trial additions or removals of water and mixing (see **Note 8**). Select molding water contents for the rest of the subspecimens to provide at least two subspecimens wet and two subspecimens dry of optimum, and molding water contents varying by about 2 %. At least two molding water contents are necessary on the wet and dry side of optimum to define the dry-unit-weight compaction curve (see **10.5**). Some

soils with very high optimum water content or a relatively flat compaction curve may require larger molding water content increments to obtain a well-defined maximum dry unit weight. Molding water content increments should not exceed about 4 %.

NOTE 8—With practice it is usually possible to visually judge a point near optimum water content. Typically, cohesive soils at the optimum water content can be squeezed into a lump that sticks together when hand pressure is released, but will break cleanly into two sections when “bent.” They tend to crumble at molding water contents dry of optimum; while, they tend to stick together in a sticky cohesive mass wet of optimum. The optimum water content is typically slightly less than the plastic limit. While for cohesionless soils, the optimum water content is typically close to zero or at the point where bleeding occurs.

10.2.2 Thoroughly mix the test fraction, then using a scoop select representative soil for each subspecimen (compaction point). Select about 2.3 kg when using Method A or B, or about 5.9 kg for Method C. Test Methods **D6913** section on Specimen and Annex A2 gives additional details on obtaining representative soil using this procedure and why it is the preferred method. To obtain the subspecimen’s molding water contents selected in **10.2.1**, add or remove the required amounts of water as follows. To add water, spray it into the soil during mixing; to remove water, allow the soil to dry in air at ambient temperature or in a drying apparatus such that the temperature of the sample does not exceed 140°F (60°C). Mix the soil frequently during drying to facilitate an even water content distribution. Thoroughly mix each subspecimen to facilitate even distribution of water throughout and then place in a separate covered container to stand (cure) in accordance with **Table 2** prior to compaction. For selecting a standing time, the soil may be classified using Practice **D2487**, Practice **D2488**, or data on other samples from the same material source. For referee testing, classification shall be by Practice **D2487**.

10.3 *Dry Preparation Method*—If the sample/specimen is too damp to be friable, reduce the water content by air drying until the material is friable. Drying may be in air or by the use of drying apparatus such that the temperature of the sample does not exceed 140°F (60°C). Thoroughly break up the aggregations in such a manner as to avoid breaking individual particles. Process the material over the appropriate sieve: No. 4 (4.75-mm), $\frac{3}{8}$ -in. (9.5-mm), or $\frac{3}{4}$ -in. (19.0-mm). When preparing the material by passing over the $\frac{3}{4}$ -in. sieve for compaction in the 6-in. mold, break up aggregations sufficiently to at least pass the $\frac{3}{8}$ -in. sieve in order to facilitate the distribution of water throughout the soil in later mixing. Determine and record the water content of the test fraction and all masses covered in **10.2**, as applicable to determine the percent oversize fraction, P_C , and test fraction, P_F .

10.3.1 From the test fraction, select and prepare at least four (preferably five) subspecimens in accordance with **10.2.1** and

TABLE 2 Required Standing Times of Moisturized Specimens

Classification	Minimum Standing Time, h
GW, GP, SW, SP	No Requirement
GM, SM	3
All other soils	16

10.2.2, except for the following: Use either a mechanical splitting or quartering process to obtain the subspecimens. As stated in Test Methods D6913, both of these processes will yield non-uniform subspecimens compared to the moist procedure. Typically, only the addition of water to each subspecimen will be required.

10.4 *Compaction*—After standing (curing), if required, each subspecimen (compaction point) shall be compacted as follows:

10.4.1 Determine and record the mass of the mold or mold and base plate, see 10.4.7.

10.4.2 Assemble and secure the mold and collar to the base plate. Check the alignment of the inner wall of the mold and mold extension collar. Adjust if necessary. The mold shall rest, without wobbling/rocking on a uniform rigid foundation, such as provided by a cylinder or cube of concrete with a weight or mass of not less than 200-lbf or 91-kg, respectively. Secure the base plate to the rigid foundation. The method of attachment to the rigid foundation shall allow easy removal of the assembled mold, collar and base plate after compaction is completed.

10.4.2.1 During compaction, it is advantageous but not required to determine the water content of each subspecimen. This provides a check on the molding water content determined for each compaction point and the magnitude of bleeding, see 10.4.9. However, more soil will have to be selected for each subspecimen than stated in 10.2.2.

10.4.3 Compact the soil in three layers. After compaction, each layer should be approximately equal in thickness and extend into the collar. Prior to compaction, place the loose soil into the mold and spread into a layer of uniform thickness. Lightly tamp the soil prior to compaction until it is not in a fluffy or loose state, using either the manual rammer or a 2±-in. (50±-mm) diameter cylinder. Following compaction of each of the first two layers, any soil that has not been

compacted; such as adjacent to the mold walls or extends above the compacted surface (up the mold walls) shall be trimmed. The trimmed soil shall be discarded. A knife or other suitable device may be used. The total amount of soil used shall be such that the third compacted layer slightly extends into the collar, but does not extend more than approximately ¼-in. (6-mm) above the top of the mold. If the third layer does extend above this limit, then the compaction point shall be discarded. In addition, the compaction point shall be discarded when the last blow on the rammer for the third layer results in the bottom of the rammer extending below the top of the compaction mold; unless the soil is pliable enough, that this surface can easily be forced above the top of the compaction mold during trimming (see Note 9).

10.4.4 Compact each layer with 25 blows for the 4-in. (101.6-mm) mold or with 56 blows for the 6-in. (152.4-mm) mold. The manual rammer shall be used for referee testing.

10.4.5 In operating the manual rammer, take care to avoid lifting the guide sleeve during the rammer upstroke. Hold the guide sleeve steady and within 5° of vertical. Apply the blows at a uniform rate of about 25 blows/min and in such a manner as to provide complete, uniform coverage of the specimen surface. When using a 4-in. (101.6-mm) mold and manual rammer, follow the blow pattern given in Fig. 3a and Fig. 3b; while for a mechanical rammer, follow the pattern in Fig. 3b. When using a 6-in. (152.4-mm) mold and manual rammer, follow the blow pattern given in Fig. 4 up to the 9th blow, then systematically around the mold (Fig. 3b) and in the middle. When using a 6-in. (152.4-mm) mold and a mechanical rammer equipped with a sector face, the mechanical rammer shall be designed to follow the compaction pattern given in Fig. 3b. When using a 6-in. (152.4-mm) mold and a mechanical rammer equipped with a circular face, the mechanical rammer shall be designed to distribute the blows uniformly over the

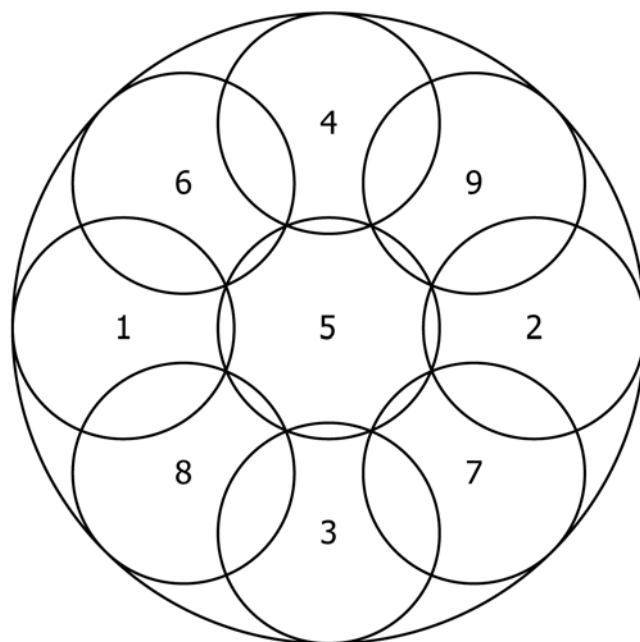

FIG. 4 Rammer Pattern for Compaction in 6 in. (152.4 mm) Mold

surface of the specimen. If the surface of the compacted soil becomes highly uneven (see [Note 9](#)), then adjust the pattern to follow the logic given in [Fig. 3a](#) or [Fig. 4](#). This will most likely void the use of a mechanical rammer for such compaction points.

NOTE 9—When compacting specimens wetter than optimum water content, uneven compacted surfaces can occur and operator judgement is required as to the average height of the specimen and rammer pattern during compaction.

10.4.6 Following compaction of the last layer, remove the collar and base plate (except as noted in [10.4.7](#)) from the mold. A knife may be used to trim the soil adjacent to the collar to loosen the soil from the collar before removal to avoid disrupting the soil below the top of the mold. In addition, to prevent/reduce soil sticking to the collar or base plate, rotate them before removal.

10.4.7 Carefully trim the compacted specimen even with the top of the mold by means of the straightedge scraped across the top of the mold to form a plane surface even with the top of the mold. Initial trimming of the specimen above the top of the mold with a knife may prevent the soil from tearing below the top of the mold. Fill any holes in the top surface with unused or trimmed soil from the specimen, press in with the fingers, and again scrape the straightedge across the top of the mold. If gravel size particles are encountered, trim around them or remove them, whichever is the easiest and reduces the disturbance of the compacted soil. The estimated volume of particles above the surface of the compacted soil and holes in that surface shall be equal, fill in remaining holes as mentioned above. Repeat the appropriate preceding operations on the bottom of the specimen when the mold volume was determined without the base plate. For very wet or dry soils, soil or water may be lost if the base plate is removed. For these situations, leave the base plate attached to the mold. When the base plate is left attached, the volume of the mold must be calibrated with the base plate attached to the mold rather than a plastic or glass plate as noted in [Annex A1, A1.4](#).

10.4.8 Determine and record the mass of the specimen and mold to the nearest g. When the base plate is left attached, determine and record the mass of the specimen, mold and base plate to the nearest g.

10.4.9 Remove the material from the mold. Obtain a specimen for molding water content by using either the whole specimen (preferred method) or a representative portion. When the entire specimen is used, break it up to facilitate drying. Otherwise, obtain a representative portion of the three layers, removing enough material from the specimen to report the water content to 0.1 %. The mass of the representative portion of soil shall conform to the requirements of Table 1, Method B, of Test Methods [D2216](#). Determine the molding water content in accordance with Test Methods [D2216](#).

10.5 Following compaction of the last specimen, compare the wet unit weights to ensure that a desired pattern of obtaining data on each side of the optimum water content will be attained for the dry-unit-weight compaction curve. Plotting the wet unit weight and molding water content of each compacted specimen can be an aid in making the above evaluation. If the desired pattern is not obtained, additional

compacted specimens will be required. Generally, for experienced plotters of compaction curves, one compaction point wet of the optimum water content is adequate to define the maximum wet unit weight, see [11.2](#).

11. Calculations and Plotting (Compaction Curve)

11.1 *Fraction Percentages*—If gradation data from Test Methods [D6913](#) is not available, calculate the dry mass of the test fraction, percentage of oversize fraction and test fraction as covered below and using the data from [10.2](#) or [10.3](#):

11.1.1 *Test Fraction*—Determine the dry mass of the test fraction as follows:

$$M_{d,tf} = \frac{M_{m,tf}}{1 + \frac{w_{tf}}{100}} \quad (1)$$

where:

- $M_{d,tf}$ = dry mass of test fraction, nearest g or 0.001 kg,
- $M_{m,tf}$ = moist mass of test fraction, nearest g or 0.001 kg, and
- w_{tf} = water content of test fraction, nearest 0.1 %.

11.1.2 *Oversize Fraction Percentage*—Determine the oversize (coarse) fraction percentage as follows:

$$P_C = \frac{M_{d,of}}{M_{d,of} + M_{d,tf}} \quad (2)$$

where:

- P_C = percentage of oversize (coarse) fraction, nearest %, and
- $M_{d,of}$ = dry mass of oversize fraction, nearest g or 0.001 kg,

11.1.3 *Test Fraction Percentage*—Determine the test (finer) fraction percentage as follows:

$$P_F = 100 - P_C \quad (3)$$

where:

- P_F = percentage of test (finer) fraction, nearest %.

11.2 *Density and Unit Weight*—Calculate the molding water content, moist density, dry density, and dry unit weight of each compacted specimen as explained below.

11.2.1 *Molding Water Content, w*—Calculate in accordance with Test Methods [D2216](#) to nearest 0.1 %.

11.2.2 *Density and Unit Weights*—Calculate the moist (total) density ([Eq 4](#)), the dry density ([Eq 5](#)), and then the dry unit weight ([Eq 6](#)) as follows:

11.2.2.1 *Moist Density:*

$$\rho_m = K \times \frac{(M_t - M_{md})}{V} \quad (4)$$

where:

- ρ_m = moist density of compacted subspecimen (compaction point), four significant digits, g/cm³ or kg/m³,
- M_t = mass of moist soil in mold and mold, nearest g,
- M_{md} = mass of compaction mold, nearest g,
- V = volume of compaction mold, cm³ or m³ (see [Annex A1](#)), and

K = conversion constant, depending on density units and volume units.
 Use 1 for g/cm^3 and volume in cm^3 .
 Use 1000 for g/cm^3 and volume in m^3 .
 Use 0.001 for kg/cm^3 and volume in m^3 .
 Use 1000 for kg/m^3 and volume in cm^3 .

11.2.2.2 Dry Density:

$$\rho_d = \frac{\rho_m}{1 + \frac{w}{100}} \quad (5)$$

where:

ρ_d = dry density of compaction point, four significant digits, g/cm^3 or kg/m^3 , and
 w = molding water content of compaction point, nearest 0.1 %.

11.2.2.3 Dry Unit Weight:

$$\gamma_d = K_1 \times \rho_d \text{ in lbf/ft}^3 \quad (6)$$

or

$$\gamma_d = K_2 \times \rho_d \text{ in kN/m}^3 \quad (7)$$

where:

γ_d = dry unit weight of compacted specimen, four significant digits, in lbf/ft^3 or kN/m^3 ,
 K_1 = conversion constant, depending on density units,
 Use 62.428 for density in g/cm^3 , or
 Use 0.062428 for density in kg/m^3 ,
 K_2 = conversion constant, depending on density units,
 Use 9.8066 for density in g/cm^3 , or
 Use 0.0098066 for density in kg/m^3 .

11.3 *Compaction Curve*—Plot the dry unit weight and molding water content values, the saturation curve (see 11.3.2), and draw the compaction curve as a smooth curve through the points (see example, Fig. 5). For each point on the compaction curve, calculate, record, and plot dry unit weight to the nearest 0.1 lbf/ft^3 (0.02 kN/m^3) and molding water content to the nearest 0.1 %. From the compaction curve, determine the compaction results: optimum water content, to nearest 0.1 % and maximum dry unit weight, to the nearest 0.1 lbf/ft^3 (0.02 kN/m^3). If more than 5 % by mass of oversize material was removed from the sample/specimen, calculate the corrected optimum water content and maximum dry unit weight of the total material using Practice D4718. This correction may be made to the appropriate field in-place density test specimen rather than to the laboratory compaction results.

11.3.1 In these plots, the scale sensitivities should remain the same, that is the change in molding water content or dry unit weight per division is constant between plots. Typically, the change in dry unit weight per division is twice that of molding water content's (2 lbf/ft^3 to 1 % w per major division). Therefore, any change in the shape of the compaction curve is a result of testing different material, not the plotting scale. However, a one to one ratio should be used for soils that have a relatively flat compaction curve (see 10.2.1), such as highly plastic soils or relatively free draining ones up to the point of bleeding.

COMPACTION TEST

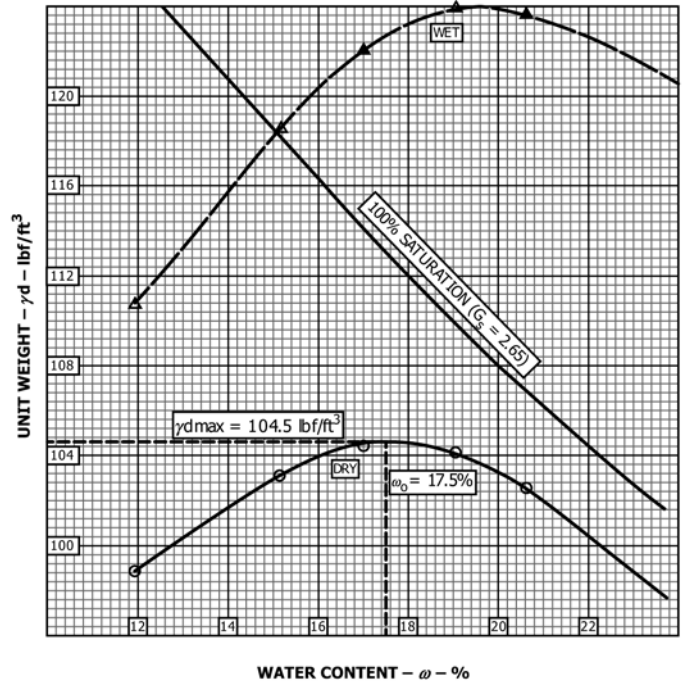

FIG. 5 Example Compaction Curve Plotting

11.3.1.1 The shape of the compaction curve on the wet side on optimum should typically follow that of the saturation curve. The shape of the compaction curve on the dry side of optimum may be relatively flat or up and down when testing some soils, such as relatively free draining ones or plastic soils prepared using the moist procedure and having molding water contents close to or less than the shrinkage limit.

11.3.2 Plot the 100 % saturation curve, based on either an estimated or a measured specific gravity. Values of water content for the condition of 100 % saturation can be calculated as explained in 11.4 (see example, Fig. 5).

NOTE 10—The 100 % saturation curve is an aid in drawing the compaction curve. For soils containing more than about 10 % fines and molding water contents well above optimum, the two curves generally become roughly parallel with the wet side of the compaction curve between 92 to 95 % saturation. Theoretically, the compaction curve cannot plot to the right of the 100 % saturation curve. If it does, there is an error in specific gravity, in measurements, in calculations, in testing, or in plotting. The 100 % saturation curve is sometimes referred to as the zero air voids curve or the complete saturation curve.

11.4 *Saturation Points*—To calculate points for plotting the 100 % saturation curve or zero air voids curve, select values of dry unit weight, calculate corresponding values of water content corresponding to the condition of 100 % saturation as follows:

$$w_{sat} = \frac{(\gamma_w)(G_s) - \gamma_d}{(\gamma_d)(G_s)} \times 100 \quad (8)$$

where:

w_{sat} = water content for complete saturation, nearest 0.1 %,
 γ_w = unit weight of water, 62.32 lbf/ft^3 (9.789 kN/m^3) at 20°C,

γ_d = dry unit weight of soil, lbf/ft³ (kN/m³), three significant digits, and
 G_s = specific gravity of soil (estimated or measured), to nearest 0.01 value, see 11.4.1.

11.4.1 Specific gravity may be estimated for the test fraction based on test data from other soils having the same soil classification and source or experience. Otherwise, a specific gravity test (Test Methods C127 or D854, or both) is necessary.

12. Report: Data Sheet(s)/Form(s)

12.1 The methodology used to specify how data are recorded on the test data sheet(s)/form(s), as described below, is covered in 1.6.

12.2 The data sheet(s)/form(s) shall contain as a minimum the following information:

- 12.2.1 Method used (A, B, or C).
- 12.2.2 Preparation method used (moist or dry).
- 12.2.3 As received water content if determined, nearest 1 %.
- 12.2.4 Standard optimum water content, Std- w_{opt} to nearest 0.1 %.
- 12.2.5 Standard maximum dry unit weight, Std- $\gamma_{d,max}$ nearest 0.1 lbf/ft³ or 0.02 kN/m³.
- 12.2.6 Type of rammer (manual or mechanical).
- 12.2.7 Soil sieve data when applicable for selection of Method (A, B, or C) used.
- 12.2.8 Description of sample used in test (as a minimum, color and group name and symbol), by Practice D2488, or classification by Practice D2487.
- 12.2.9 Specific gravity and method of determination, nearest 0.01 value.
- 12.2.10 Identification of sample used in test; for example, project number/name, location, depth, and the like.
- 12.2.11 Compaction curve plot showing compaction points used to establish compaction curve, and 100 % saturation curve, value or point of maximum dry unit weight and optimum water content.
- 12.2.12 Percentages for the fractions retained (P_C) and passing (P_F) the sieve used in Method A, B, or C, nearest 1 %. In addition, if compaction data (Std- w_{opt} and Std- $\gamma_{d,max}$) are corrected for the oversize fraction, include that data.

13. Precision and Bias

13.1 *Precision*—Criteria for judging the acceptability of test results obtained by these test methods on a range of soil types are given in Tables 3 and 4. These estimates of precision are based on the results of the interlaboratory program conducted by the ASTM Reference Soils and Testing Program.⁴ In this program, Method A and the Dry Preparation Method were used. In addition, some laboratories performed three replicate tests per soil type (triplicate test laboratory), while other laboratories performed a single test per soil type (single test laboratory). A description of the soils tested is given in 13.1.4. The precision estimates vary with soil type, and may vary with methods used (Method A, B, or C, or wet/dry preparation

TABLE 3 Summary of Test Results from Triplicate Test Laboratories (Standard Effort Compaction)

(1) Number of Triplicate Test Labs			(2) Test Value ^A (Units)	(3) Average Value ^B	(4) Standard Deviation ^C	(5) Acceptable Range of Two Results ^{D,E}
<i>Soil Type:</i>						
CH	CL	ML	CH CL ML	CH CL ML	CH CL ML	CH CL ML
<i>Single-Operator Results (Within-Laboratory Repeatability):</i>						
11	12	11	$\gamma_{d,max}$ (pcf)	97.2 109.2 106.3	0.5 0.4 0.5	1.3 1.2 1.3
11	12	11	w_{opt} (%)	22.8 16.6 17.1	0.2 0.3 0.3	0.7 0.9 0.9
<i>Multilaboratory Results (Between-Laboratory Reproducibility):</i>						
11	12	11	$\gamma_{d,max}$ (pcf)	97.2 109.2 106.3	1.4 0.8 0.6	3.9 2.3 1.6
11	12	11	w_{opt} (%)	22.8 16.6 17.1	0.7 0.5 0.5	1.8 1.5 1.3

^A $\gamma_{d,max}$ (pcf) = standard maximum dry unit weight in lbf/ft³ and w_{opt} (%) = standard optimum water in percent.

^B The number of significant digits and decimal places presented are representative of the input data. In accordance with Practice D6026, the standard deviation and acceptable range of results can not have more decimal places than the input data.

^C Standard deviation is calculated in accordance with Practice E691 and is referred to as the 1 s limit.

^D Acceptable range of two results is referred to as the d2s limit. It is calculated as $1.960 \sqrt{2} \cdot 1s$, as defined by Practice E177. The difference between two properly conducted tests should not exceed this limit. The number of significant digits/decimal places presented is equal to that prescribed by this standard or Practice D6026. In addition, the value presented can have the same number of decimal places as the standard deviation, even if that result has more significant digits than the standard deviation.

^E Both values of $\gamma_{d,max}$ and w_{opt} have to fall within values given for the selected soil type.

TABLE 4 Summary of Single Test Results from Each Laboratories (Standard Effort Compaction)^A

(1) Number of Test Laboratories			(2) Test Value (Units)	(3) Average Value	(4) Standard Deviation	(5) Acceptable Range of Two Results
<i>Soil Type:</i>						
CH	CL	ML	CH CL ML	CH CL ML	CH CL ML	CH CL ML
<i>Multilaboratory Results (Between-Laboratory Reproducibility):</i>						
26	26	25	$\gamma_{d,max}$ (pcf)	97.3 109.2 106.2	1.6 1.1 1.0	4.5 3.0 2.9
			w_{opt} (%)	22.6 16.4 16.7	0.9 0.7 1.0	2.4 1.8 2.9

^A See footnotes in Table 3.

method). Judgement is required when applying these estimates to another soil, method, or preparation method.

13.1.1 The data in Table 3 are based on three replicate tests performed by each triplicate test laboratory on each soil type. The single operator and multilaboratory standard deviation show in Table 3, Column 4 were obtained in accordance with Practice E691, which recommends each testing laboratory perform a minimum of three replicate tests. Results of two properly conducted tests performed by the same operator on the same material, using the same equipment, and in the shortest practical period of time should not differ by more than the single-operator d2s shown in Table 3, Column 5. For definition of d2s, see footnote D in Table 1. Results of two properly conducted tests performed by different operators and on different days should not differ by more than the multilaboratory d2s limits shown in Table 3, Column 5.

13.1.2 In the ASTM Reference Soils and Testing Program, many of the laboratories performed only a single test on each

⁴ Supporting data have been filed at ASTM International Headquarters and may be obtained by requesting Research Report RR:D18-1008. Contact ASTM Customer Service at service@astm.org.

soil type. This is common practice in the design and construction industry. The data for each soil type in **Table 4** are based upon the first test result from the triplicate test laboratories and the single test results from the other laboratories. Results of two properly conducted tests performed by two different laboratories with different operators using different equipment and on different days should not vary by more than the d_{2s} limits shown in **Table 4**, Column 5. The results in **Tables 3 and 4** are dissimilar because the data sets are different.

13.1.3 **Table 3** presents a rigorous interpretation of triplicate test data in accordance with Practice **E691** from pre-qualified laboratories. **Table 4** is derived from test data that represents common practice.

13.1.4 *Soil Types*—Based on the multilaboratory test results the soils used in the program are described below in accordance with Practice **D2487**. In addition, the local names of the soils are given.

CH	Fat clay, CH, 99 % fines, LL=60, PI=39, grayish brown, soil had been air dried and pulverized. Local name—Vicksburg Buckshot Clay
CL	Lean clay, CL, 89 % fines, LL=33, PI=13, gray, soil had been air dried and pulverized. Local name—Annapolis Clay
ML	Silt, ML, 99 % fines, LL=27, PI=4, light brown, soil had been air dried and pulverized. Local name—Vicksburg Silt

13.2 *Bias*—There is no accepted reference values for this test method, therefore, bias cannot be determined.

14. Keywords

14.1 compaction characteristics; density; impact compaction; laboratory tests ; moisture-density curves; proctor test; soil; soil compaction; standard effort

ANNEX

(Mandatory Information)

A1. VOLUME OF COMPACTION MOLD

A1.1 Scope

A1.1.1 This annex describes the procedure for determining the volume of a compaction mold.

A1.1.2 The volume is determined by two methods, a water-filled and linear-measurement method.

A1.1.3 The water filling method for the 4-in. (106.5-mm) mold, when using a balance readable to nearest g, does not yield four significant figures for its volume, just three. Based on Practice **D6026**, this limits the density/unit weight determinations previously presented from four to three significant figures. To prevent this limitation, the water filling method has been adjusted from that presented in early versions of this test method.

A1.2 Apparatus

A1.2.1 In addition to the apparatus listed in Section **6** the following items are required:

A1.2.1.1 *Vernier or Dial Caliper*, having a measuring range of at least 0 to 6 in. (0 to 150 mm) and readable to at least 0.001 in. (0.02 mm).

A1.2.1.2 *Inside Micrometer (optional)*, having a measuring range of at least 2 to 12 in. (50 to 300 mm) and readable to at least 0.001 in. (0.02 mm).

A1.2.1.3 *Depth Micrometer (optional)*, having a measuring range of at least 0 to 6 in. (0 to 150 mm) and readable to at least 0.001 in. (0.02 mm).

A1.2.1.4 *Plastic or Glass Plates*—Two plastic or glass plates about 8 in. square by ¼ in. thick (200 by 200 by 6 mm).

A1.2.1.5 *Thermometer or Other Thermometric Device*, having graduation increments of 0.1°C.

A1.2.1.6 *Stopcock Grease*, or similar sealant.

A1.2.1.7 *Miscellaneous Equipment*—Bulb syringe, towels, etc.

A1.3 Precautions

A1.3.1 Perform this method in an area isolated from drafts or extreme temperature fluctuations.

A1.4 Procedure

A1.4.1 *Water-Filling Method:*

A1.4.1.1 Lightly grease the bottom of the compaction mold and place it on one of the plastic or glass plates. Lightly grease the top of the mold. Be careful not to get grease on the inside of the mold. If it is necessary to use the base plate, as noted in **10.4.7**, place the greased mold onto the base plate and secure with the locking studs.

A1.4.1.2 Determine the mass of the greased mold and both plastic or glass plates to the nearest 1 g and record, M_{mp} . When the base plate is being used in lieu of the bottom plastic or glass plate, determine the mass of the mold, base plate and a single plastic or glass plate to be used on top of the mold to the nearest 1 g and record.

A1.4.1.3 Place the mold and the bottom plastic or glass plate on a firm, level surface and fill the mold with water to slightly above its rim.

A1.4.1.4 Slide the second plate over the top surface of the mold so that the mold remains completely filled with water and air bubbles are not entrapped. Add or remove water as necessary with a bulb syringe.

A1.4.1.5 Completely dry any excess water from the outside of the mold and plates.

A1.4.1.6 Determine the mass of the mold, plates and water and record to the nearest 1 g, $M_{mp,w}$.

A1.4.1.7 Determine the temperature of the water in the mold to the nearest 0.1°C and record. Determine and record the density of water from the table given in Test Methods **D854** or as follows:

$$\rho_{w,c} = 1.00034038 - (7.77 \times 10^{-6}) \times T - (4.95 \times 10^{-6}) \times T^2 \quad (\text{A1.1})$$

where:

$\rho_{w,c}$ = density of water, nearest 0.00001 g/cm³, and
 T = calibration test temperature, nearest 0.1°C.

A1.4.1.8 Calculate the mass of water in the mold by subtracting the mass determined in **A1.4.1.2** from the mass determined in **A1.4.1.6**.

A1.4.1.9 Calculate the volume of water by dividing the mass of water by the density of water. Record this volume to the nearest 0.1 cm³ for the 4-in. (101.6-mm) mold or nearest 1 cm³ for the 6-in. (152.4-mm) mold. To determine the volume of the mold in m³, multiply the volume in cm³ by 1 × 10⁻⁶. Record this volume, as prescribed.

A1.4.1.10 If the filling method is being used to determine the mold's volume and checked by linear measurement method, repeat this volume determination (**A1.4.1.3 – A1.4.1.9**) and determine and record the average value, V_w as prescribed.

A1.4.2 Linear Measurement Method:

A1.4.2.1 Using either the vernier caliper or the inside micrometer (preferable), measure the inside diameter (ID) of the mold 6 times at the top of the mold and 6 times at the bottom of the mold, spacing each of the six top and bottom measurements equally around the ID of the mold. Record the values to the nearest 0.001-in. (0.02-mm). Determine and record the average ID to the nearest 0.001-in. (0.02-mm), d_{avg} . Verify that this ID is within specified tolerances, 4.000 ± 0.016 in. (101.6 ± 0.4 mm), if not discard the mold.

A1.4.2.2 Using the vernier caliper or depth micrometer (preferably), measure the inside height of the mold attached to the base plate. In these measurements, make three or more measurements equally spaced around the ID of the mold, and preferably one in the center of the mold, but not required (used the straightedge to facilitate the later measurement and correct measurement for thickness of straightedge). Record these values to the nearest 0.001-in. (0.02-mm). Determine and

record the average of these height measurements to the nearest 0.001 in. (0.02 mm), h_{avg} . Verify that this height is within specified tolerances, 4.584 ± 0.018 in. (116.4 ± 0.5 mm), if not discard the mold.

A1.4.2.3 Calculate the volume of the mold to four significant digits in cm³ as follows:

$$V_{lm} = K_3 \frac{\pi \times h_{avg} \times (d_{avg})^2}{4} \quad (\text{A1.2})$$

where:

V_{lm} = volume of mold by linear measurements, to four significant digits, cm³,

K_3 = constant to convert measurements made in inch (in.) or mm,

Use 16.387 for measurements in inches.

Use 10⁻³ for measurements in mm.

π = 3.14159,

h_{avg} = average height, in. (mm), and

d_{avg} = average of the top and bottom diameters, in. (mm).

A1.4.2.4 If the volume in m³ is required, then multiply the above value by 10⁻⁶.

A1.5 Comparison of Results and Standardized Volume of Mold

A1.5.1 The volume obtained by either method should be within the volume tolerance requirements of **6.1.1** and **6.1.2**, using either or cm³ to ft³. To convert cm³ to ft³, divide cm³ by 28 317, record to the nearest 0.0001 ft³.

A1.5.2 The difference between the two methods should not exceed 0.5 % of the nominal volume of the mold, cm³ to ft³.

A1.5.3 Repeat the determination of volume, which is most suspect or both if these criteria are not met.

A1.5.4 Failure to obtain satisfactory agreement, between these methods, even after several trials is an indication the mold is badly deformed and should be replaced.

A1.5.5 Use the volume of the mold determined using the water-filling or linear method, or average of both methods as the standardized volume for calculating the moist density (see **11.4**). This value (V) in cm³ or m³ shall have four significant digits. The use of a volume in ft³, along with masses in lbm shall not be regarded as a nonconformance with this standard.

REFERENCES

- (1) Johnson, A. W., and Sallberg, J. R., *Factors Influencing Compaction Test Results*, Highway Research Board, Bulletin 318, Publication 967, National Academy of Sciences-National Research Council, Washington, DC, 1962.
- (2) *Earth Manual*, United States Bureau of Reclamation, Part 1, Third Edition, 1998, pp. 255–260.
- (3) *Earth Manual*, United States Bureau of Reclamation, Part 2, Third Edition, 1990, USBR 5515.
- (4) Torrey, V. H., and Donaghe, R. T., “Compaction Control of Earth-Rock Mixtures: A New Approach,” *Geotechnical Testing Journal*, GTJODJ, Vol 17, No. 3, September 1994, pp. 371–386.

SUMMARY OF CHANGES

Committee D18 has identified the location of selected changes to this standard since the last issue (D698–07^{e1}) that may impact the use of this standard. (Approved May 1, 2012.)

- (1) Revised 6.2.2.1 and 10.4.5.

ASTM International takes no position respecting the validity of any patent rights asserted in connection with any item mentioned in this standard. Users of this standard are expressly advised that determination of the validity of any such patent rights, and the risk of infringement of such rights, are entirely their own responsibility.

This standard is subject to revision at any time by the responsible technical committee and must be reviewed every five years and if not revised, either reapproved or withdrawn. Your comments are invited either for revision of this standard or for additional standards and should be addressed to ASTM International Headquarters. Your comments will receive careful consideration at a meeting of the responsible technical committee, which you may attend. If you feel that your comments have not received a fair hearing you should make your views known to the ASTM Committee on Standards, at the address shown below.

This standard is copyrighted by ASTM International, 100 Barr Harbor Drive, PO Box C700, West Conshohocken, PA 19428-2959, United States. Individual reprints (single or multiple copies) of this standard may be obtained by contacting ASTM at the above address or at 610-832-9585 (phone), 610-832-9555 (fax), or service@astm.org (e-mail); or through the ASTM website (www.astm.org). Permission rights to photocopy the standard may also be secured from the Copyright Clearance Center, 222 Rosewood Drive, Danvers, MA 01923, Tel: (978) 646-2600; <http://www.copyright.com/>