



Standard Practice for Measuring Sifting Segregation Tendencies of Bulk Solids¹

This standard is issued under the fixed designation D6940; the number immediately following the designation indicates the year of original adoption or, in the case of revision, the year of last revision. A number in parentheses indicates the year of last reappraisal. A superscript epsilon (ϵ) indicates an editorial change since the last revision or reappraisal.

1. Scope*

1.1 This practice covers an apparatus and procedure for simulating the segregation tendencies of bulk solids by means of the sifting mechanism.

1.2 Temperature- and humidity-sensitive bulk solids may need to be tested at different temperatures and moisture contents, as would happen in an industrial environment.

1.3 The maximum particle size should be limited to 3 mm, to reduce the likelihood of binding the slide gate.

1.4 This standard is not applicable to all bulk solids and segregation mechanisms: while sifting is a common segregation mechanism experienced by many bulk solids, other segregation mechanisms not evaluated by this standard might induce segregation in practice. Practice D6941 covers another common mechanism: fluidization.

1.5 The extent to which segregation will occur in an industrial situation is not only a function of the bulk solid and its tendency to segregate, but also the handling equipment (for example, bin design), process (for example, transfer rates), and environment.

1.6 The values stated in SI units are to be regarded as standard. No other units of measurement are included in this standard.

1.7 *This standard does not purport to address all of the safety concerns, if any, associated with its use. It is the responsibility of the user of this standard to establish appropriate safety and health practices and determine the applicability of regulatory limitations prior to use.*

2. Referenced Documents

2.1 ASTM Standards:²

D653 Terminology Relating to Soil, Rock, and Contained Fluids

¹ This practice is under the jurisdiction of ASTM Committee D18 on Soil and Rock and is the direct responsibility of Subcommittee D18.24 on Characterization and Handling of Powders and Bulk Solids.

Current edition approved July 1, 2010. Published August 2010. Originally approved in 2003. Last previous edition approved in 2004 as D6940-04. DOI: 10.1520/D6940-10.

² For referenced ASTM standards, visit the ASTM website, www.astm.org, or contact ASTM Customer Service at service@astm.org. For Annual Book of ASTM Standards volume information, refer to the standard's Document Summary page on the ASTM website.

D2216 Test Methods for Laboratory Determination of Water (Moisture) Content of Soil and Rock by Mass
D3740 Practice for Minimum Requirements for Agencies Engaged in Testing and/or Inspection of Soil and Rock as Used in Engineering Design and Construction
D6941 Practice for Measuring Fluidization Segregation Tendencies of Powders

3. Terminology

3.1 Definitions:

3.1.1 For common definitions of terms in this standard, refer to Terminology D653.

3.1.2 *funnel flow pattern, n*—a flow sequence in a bin or hopper characterized by having some bulk solids moving through stagnant bulk solids. In general, there is no flow along the hopper walls.

3.1.3 *segregation, n*—a process through which blended or uniform powders or bulk solids become non-uniform, with regions of varying composition, for example, particle size.

3.1.4 *sifting segregation, n*—a mechanism in which finer particles preferentially percolate into a zone within the bulk solid.

3.2 Definitions of Terms Specific to This Standard:

3.2.1 *collection cup, n*—a collection cup holds a specimen of bulk solid once it is discharged from the apparatus.

3.2.2 *inner hopper, n*—the inner hopper is transparent. It has a steep inner conical section designed to sit within the outer hopper.

3.2.3 *outer hopper, n*—the outer hopper consists of a shallow transparent hopper designed to provide funnel flow for most bulk solids. It has an attached slide gate/guide cylinder and support legs.

3.2.4 *representative sample, n*—a quantity of the bulk solid to be tested that is representative of that solid in an industrial application being studied. Parameters of interest that may affect whether or not a sample is representative include, but are not limited to: moisture, particle size distribution, raw material variation, method of production, aging, chemical composition.

4. Summary of Practice

4.1 A representative sample of a bulk solid is placed in the upper hopper of the apparatus.

*A Summary of Changes section appears at the end of this standard

4.2 The bulk solid is discharged to form a pile within the lower hopper, allowing segregation to take place.

4.3 The segregated material is discharged in a funnel flow pattern intended to recover zones of segregated material in a known sequence. Specimens are collected from the discharge stream.

4.4 The specimens are then available to be tested for differences relevant to the application, for example, particle size or chemical assay.

5. Significance and Use

5.1 Sifting segregation can cause horizontal segregation (for example, center-to-periphery) within bins used to hold and transport bulk solids. This can affect final product quality in industrial applications.

5.2 By measuring a bulk solid's segregation tendency, one can compare results to other bulk solids with known history, or determine if the given bulk solid may have a tendency to segregate in a given process.

5.3 Sifting, which is a process by which smaller particles move through a matrix of larger ones, is a common method of segregation. Four conditions must exist for sifting to occur:

5.3.1 *A Difference in Particle Size between the Individual Components*—This ratio can be as low as 1.3 to 1. In general, the larger the ratio of particle sizes, the greater the tendency for particles to segregate by sifting.

5.3.2 *A Sufficiently Large Mean Particle Size*—Sifting segregation can occur with a mean particle size in the 50 μm range and can become a dominant segregation mechanism if the mean particle size is above 100 μm .

5.3.3 *Sufficiently Free Flowing Material*—This allows the smaller particles to sift through the matrix of larger particles. With cohesive materials, the fine particles are bound to one another and do not enter the voids among the coarse particles.

5.3.4 *Interparticle Motion*—This can be caused during formation of a pile, by vibration, or by a velocity gradient across the flowing material.

5.4 All four of these conditions must exist for sifting segregation to occur. If any one of these conditions does not exist, the material will not segregate by this mechanism.

NOTE 1—The quality of the result produced by this practice is dependent on the competence of the personnel performing it, and the suitability of the equipment and facilities used. Agencies that meet the criteria of Practice D3740 are generally considered capable of competent and objective testing/sampling/inspection/etc. Users of this practice are cautioned that compliance with Practice D3740 does not in itself assure reliable results. Reliable results depend on many factors; Practice D3740 provides a means of evaluating some of those factors.

Practice D3740 was developed for agencies engaged in the testing and/or inspection of soil and rock. As such it is not totally applicable to agencies performing this practice. However, users of this practice should recognize that the framework of Practice D3740 is appropriate for evaluating the quality of an agency performing this practice. Currently there is no known qualifying national authority that inspects agencies that perform this practice.

6. Apparatus

6.1 The apparatus is shown in Fig. 1, and all critical dimensions are specified in Fig. 2. The apparatus consists of the following:

6.2 An upper hopper assembly consisting of an inner hopper seated within an outer hopper. This outer hopper provides support for the inner hopper, and has a slide gate to start/stop material flow. The outer hopper also has support legs, which mate to the lower hopper assembly.

NOTE 2—Although only the inner hopper is used to contain the bulk solid being tested, placing this hopper inside the outer hopper provides a means to locate and support it, as well as a means to fill and empty the hopper (by using the slide gate). In addition, this outer hopper can be used for alternate test procedures that involve recycling material to and from a hopper of similar type. In this case a second inner hopper is also required.

6.3 A lower hopper assembly consisting of a second outer hopper. This outer hopper provides support for the upper hopper assembly, has a slide gate to start/stop material flow, and a guide cylinder for dispensing material into collecting cups. The outer hopper also has support legs to support the entire segregation tester.

6.4 A collecting cup with a minimum capacity of 55 mL, to collect specimens as they discharge from the lower hopper. The collecting cups must fit within the apparatus.

7. Procedure

7.1 Clean the apparatus and allow all parts to dry.

7.2 With inner hopper removed, place one outer hopper on top of the other. Make sure that the centerlines of the two hoppers are aligned.

7.3 Place the inner hopper into the upper outer hopper.

7.4 Close the slide gates on both outer hoppers.

7.5 Place the apparatus on a table or bench that is free from vibration, in a suitable laboratory environment to approximate the industrial environment. Ensure that the apparatus is level.

7.6 Obtain a representative, one-liter sample of the bulk solid to be tested. The maximum particle size should be limited to 3 mm, to reduce the likelihood of binding the slide gate.

7.7 Carefully spoon or scoop the bulk solid into the upper inner hopper. Free fall of material into the hopper should be minimized.

7.8 Open the upper slide gate to the full open position, allowing the entire sample to fall into the lower hopper.

7.9 Cohesive materials may not readily flow through this apparatus. For moderately cohesive materials that flow poorly through this apparatus, some light tapping on the hopper may be required to maintain flow. Extremely cohesive materials, which do not flow with light tapping, should not be tested to avoid damage to the apparatus (further, extremely cohesive materials generally do not readily segregate).

7.10 When the upper inner hopper is empty, close the upper hopper slide gate, remove the upper hopper assembly and set it aside.

7.11 With the lower hopper slide gate still closed, place a collecting cup over the open end of the guide cylinder so that the bottom of the cup is in contact with the bottom of the guide cylinder.

NOTE 3—The bottom of the guide cylinder must remain in contact with the base of the cup.

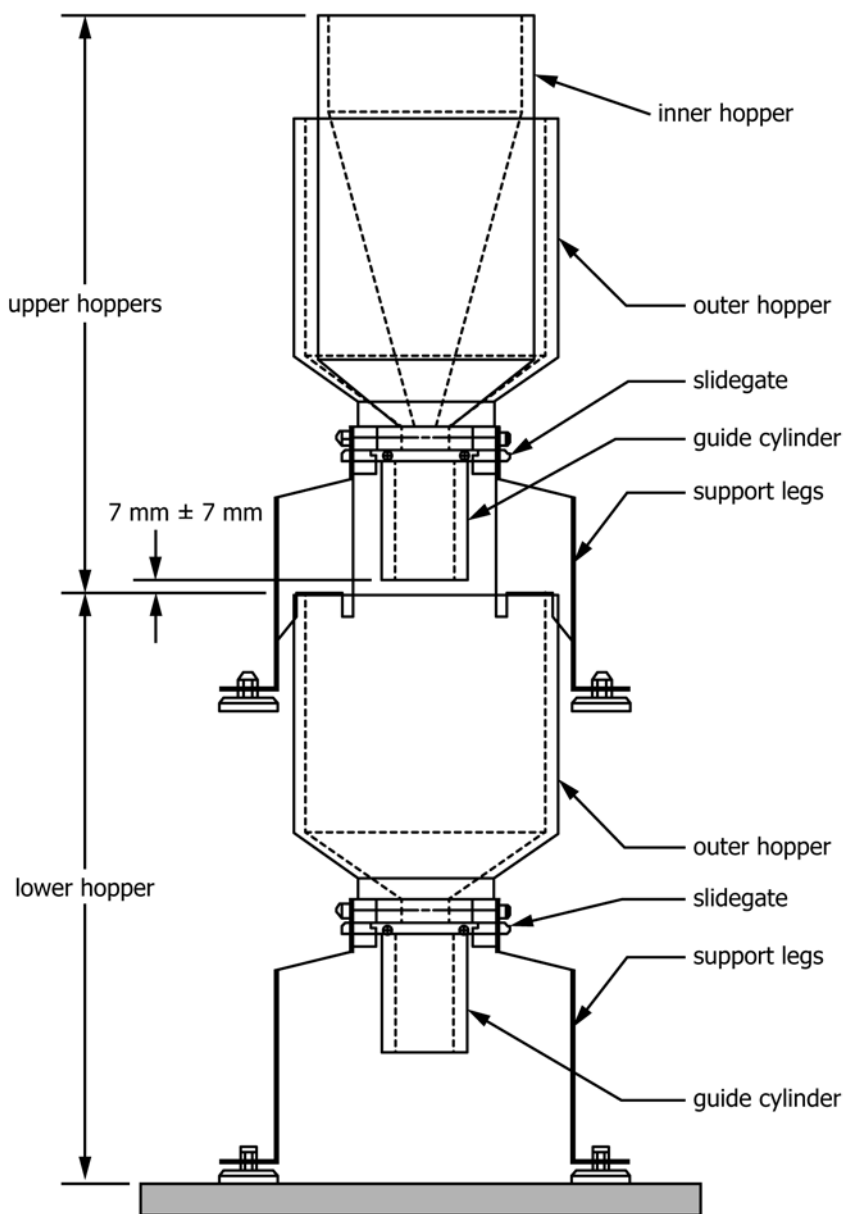

FIG. 1 Apparatus

7.12 With the cup and guide cylinder together, open the lower hopper slide gate and allow the guide cylinder to fill.

NOTE 4—Do not lower the cup at this time. Doing so will result in material spillage and will void this practice.

7.13 When the guide cylinder is full, close the lower hopper slide gate completely, and then lower the collecting cup.

7.14 Discharge from the lower outer hopper will be in a funnel flow pattern for most bulk solids. An exception might occur for free flowing, low friction materials such as beads or glass spheres. If the material is sliding along the walls during discharge (“mass flow”), then the test results will not be valid; in this case, roughen the hopper surface (for example, attach sandpaper) and begin the procedure again.

7.15 Discharge the specimen in the collecting cup into a properly identified specimen jar.

7.16 Repeat 7.11 – 7.15 until the lower hopper is empty. Approximately 19 specimens will be obtained.

8. Analysis of Specimens

8.1 If needed, use appropriate splitting methods to reduce the size of the specimens in each of the specimen jars to a suitable size for analysis. Use proper subdivision techniques, such as the use of a rotary riffler.

NOTE 5—Collecting sub-specimens from the specimen jars by scooping or thieving may be prone to errors. Analysis of multiple specimens from a single location yields further confidence in the results.

8.2 Analyze the specimens or sub-specimens with respect to the parameters of interest: particle size, particle shape, chemical assay, bulk density, color, solubility, or any other differences that may affect the suitability of the bulk solid.

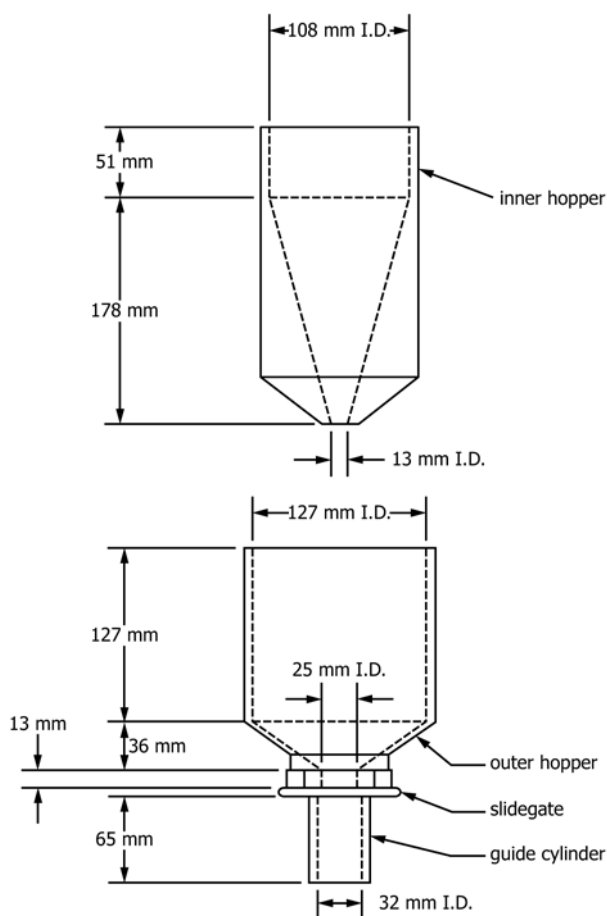

FIG. 2 Dimensions of Apparatus

8.3 The trend from the beginning to the end of discharge is an indication of segregation potential. Normally, if sifting segregation has occurred upon filling, fines discharge initially, with increasing coarse to the end.

NOTE 6—In some cases, the very last specimen may also be high in fines, for a variety of reasons. For example, if the initial zone of fines exceeds the diameter of the outlet, not all fines will discharge at the beginning, and may discharge at the very end. Another reason for fines at the end is due to sifting of the material from the moving flow channel into the stagnant zone during discharge; this layer often discharges at the very end. (To investigate this later scenario, scoop material directly into the lower outer hopper in a way to maintain a good blend in the hopper, then continue from 7.11. If the last specimen is fine, segregation within the flow channel is occurring.)

8.4 The difference between the first and last specimens can be used as an indicator of segregation potential when a single-valued result is needed for comparison of different specimens.

NOTE 7—Generally the last collection cup will not be as full as the other cups. If the last cup of material is less than half the volume of the other cups, then the reported difference should be the difference between the first and last full cups (that is, next to last cup).

8.5 Segregation test results for a new bulk solid should be compared to prior tests on other bulk solids, whose segregation properties are well known and understood.

9. Report

9.1 Record as a minimum the following general information:

- 9.1.1 Requesting agency or client or identifying number or both for job or project,
- 9.1.2 Technician, and
- 9.1.3 Date test was run.

9.2 Record as a minimum the following test data:

- 9.2.1 Generic name of sample,
- 9.2.2 Chemical name of sample, if known,
- 9.2.3 Sample moisture (water) content, if determined. Record value to nearest 0.1 %. Indicate method used to determine moisture if not Test Method D2216,
- 9.2.4 Temperature and relative humidity of room where tests performed,
- 9.2.5 Number of specimen jars collected,
- 9.2.6 Number of last full specimen jar, and
- 9.2.7 Any observations of interest during running of tests, including the need for tapping to initiate or maintain flow.

10. Keywords

- 10.1 bulk solids; segregation; sifting

SUMMARY OF CHANGES

Committee D18 has identified the location of selected changes to this practice since the last issue, D6940–04, that may impact the use of this practice. (Approved July 1, 2010)

- (1) Replaced most instances of “sample” with “specimen.”
- (2) Added reference to Test Method **D2216** and Practice **D6941**.
- (3) Revised Section **9**, including the title.
- (4) Made minor changes to dimensions in **Fig. 2**.

ASTM International takes no position respecting the validity of any patent rights asserted in connection with any item mentioned in this standard. Users of this standard are expressly advised that determination of the validity of any such patent rights, and the risk of infringement of such rights, are entirely their own responsibility.

This standard is subject to revision at any time by the responsible technical committee and must be reviewed every five years and if not revised, either reapproved or withdrawn. Your comments are invited either for revision of this standard or for additional standards and should be addressed to ASTM International Headquarters. Your comments will receive careful consideration at a meeting of the responsible technical committee, which you may attend. If you feel that your comments have not received a fair hearing you should make your views known to the ASTM Committee on Standards, at the address shown below.

This standard is copyrighted by ASTM International, 100 Barr Harbor Drive, PO Box C700, West Conshohocken, PA 19428-2959, United States. Individual reprints (single or multiple copies) of this standard may be obtained by contacting ASTM at the above address or at 610-832-9585 (phone), 610-832-9555 (fax), or service@astm.org (e-mail); or through the ASTM website (www.astm.org). Permission rights to photocopy the standard may also be secured from the Copyright Clearance Center, 222 Rosewood Drive, Danvers, MA 01923, Tel: (978) 646-2600; <http://www.copyright.com/>