



Designation: D6931 – 17

# Standard Test Method for Indirect Tensile (IDT) Strength of Asphalt Mixtures<sup>1</sup>

This standard is issued under the fixed designation D6931; the number immediately following the designation indicates the year of original adoption or, in the case of revision, the year of last revision. A number in parentheses indicates the year of last reapproval. A superscript epsilon ( $\epsilon$ ) indicates an editorial change since the last revision or reapproval.

## 1. Scope

1.1 This test method covers procedures for preparing and testing laboratory-fabricated or field-recovered cores of asphalt mixtures to determine the indirect tensile (IDT) strength.

1.2 The values stated in SI units are to be regarded as standard. No other units of measurement are included in this standard.

1.3 *This standard does not purport to address all of the safety concerns, if any, associated with its use. It is the responsibility of the user of this standard to establish appropriate safety and health practices and determine the applicability of regulatory limitations prior to use.*

1.4 *This international standard was developed in accordance with internationally recognized principles on standardization established in the Decision on Principles for the Development of International Standards, Guides and Recommendations issued by the World Trade Organization Technical Barriers to Trade (TBT) Committee.*

## 2. Referenced Documents

2.1 *ASTM Standards:*<sup>2</sup>

[D1074 Test Method for Compressive Strength of Asphalt Mixtures](#)

[D1561/D1561M Practice for Preparation of Bituminous Mixture Test Specimens by Means of California Kneading Compactor](#)

[D3387 Test Method for Compaction and Shear Properties of Bituminous Mixtures by Means of the U.S. Corps of Engineers Gyratory Testing Machine \(GTM\)](#)

[D3496 Practice for Preparation of Bituminous Mixture Specimens for Dynamic Modulus Testing \(Withdrawn 2010\)](#)<sup>3</sup>

<sup>1</sup> This test method is under the jurisdiction of ASTM Committee D04 on Road and Paving Materials and is the direct responsibility of Subcommittee D04.26 on Fundamental/Mechanistic Tests.

Current edition approved July 1, 2017. Published July 2017. Originally approved in 2007. Last previous edition approved in 2012 as D6931 – 12. DOI: 10.1520/D6931-17.

<sup>2</sup> For referenced ASTM standards, visit the ASTM website, [www.astm.org](http://www.astm.org), or contact ASTM Customer Service at [service@astm.org](mailto:service@astm.org). For *Annual Book of ASTM Standards* volume information, refer to the standard's Document Summary page on the ASTM website.

<sup>3</sup> The last approved version of this historical standard is referenced on [www.astm.org](http://www.astm.org).

[D3549/D3549M Test Method for Thickness or Height of Compacted Bituminous Paving Mixture Specimens](#)

[D3666 Specification for Minimum Requirements for Agencies Testing and Inspecting Road and Paving Materials](#)

[D4013 Practice for Preparation of Test Specimens of Bituminous Mixtures by Means of Gyratory Shear Compactor \(Withdrawn 2013\)](#)<sup>3</sup>

[D4867/D4867M Test Method for Effect of Moisture on Asphalt Concrete Paving Mixtures](#)

[D5581 Test Method for Resistance to Plastic Flow of Bituminous Mixtures Using Marshall Apparatus \(6 inch-Diameter Specimen\)](#)

[D6925 Test Method for Preparation and Determination of the Relative Density of Asphalt Mix Specimens by Means of the Superpave Gyratory Compactor](#)

[D6926 Practice for Preparation of Asphalt Mixture Specimens Using Marshall Apparatus](#)

[D6927 Test Method for Marshall Stability and Flow of Asphalt Mixtures](#)

[E1 Specification for ASTM Liquid-in-Glass Thermometers](#)

2.2 *AASHTO Standards:*<sup>4</sup>

[AASHTO T 245 Standard Method for Resistance to Plastic Flow of Bituminous Mixtures Using Marshall Apparatus](#)

[AASHTO T 312 Standard Method for Preparing and Determining the Density of Hot Mix Asphalt \(HMA\) Specimens by Means of the Superpave Gyratory Compactor](#)

## 3. Summary of Test Method

3.1 The IDT strength of asphalt mixtures is determined by loading a cylindrical specimen across its vertical diametral plane at a specified rate of deformation and test temperature. The peak load at failure is recorded and used to calculate the IDT strength of the specimen.

## 4. Significance and Use

4.1 The values of IDT strength may be used to evaluate the relative quality of asphalt mixtures in conjunction with laboratory mix design testing and for estimating the potential for rutting or cracking. The results can also be used to determine

<sup>4</sup> Available from American Association of State Highway and Transportation Officials (AASHTO), 444 N. Capitol St., NW, Suite 249, Washington, DC 20001, <http://www.transportation.org>.

the potential for field pavement moisture damage when results are obtained on both moisture-conditioned and unconditioned specimens.

NOTE 1—The quality of the results produced by this standard are dependent on the competence of the personnel performing the procedure and the capability, calibration, and maintenance of the equipment used. Agencies that meet the criteria of Specification D3666 are generally considered capable of competent and objective testing, sampling, inspection, etc. Users of this standard are cautioned that compliance with Specification D3666 alone does not completely ensure reliable results. Reliable results depend on many factors; following the suggestions of Specification D3666 or some similar acceptable guideline provides a means of evaluating and controlling some of those factors.

## 5. Apparatus

5.1 *Loading Device*—Loading jack and ring dynamometer or a mechanical or servo-hydraulic testing machine with an electronic load cell, in accordance with Test Method D6927, capable of applying a compressive load at a controlled deformation rate while measuring the load and deformation.

5.2 *Loading Strips*—Steel loading strips with a concave surface having a radius of curvature equal to the nominal radius of the test specimen. For specimens with nominal diameter of 100 mm, the loading strips shall be  $12.70 \pm 0.3$  mm wide. For specimens with nominal diameter of 150 mm, the loading strips shall be  $19.05 \pm 0.3$  mm wide. The length of the loading strips shall exceed the thickness of the specimen. The outer edges of the loading strips shall be beveled slightly to remove sharp edges.

5.2.1 The loading strips shall be part of a test fixture, similar to that shown in Fig. 1, in which the lower loading strip is mounted on a base having two perpendicular guide rods or posts extending upward. The upper loading strip shall be clean and freely sliding on the posts. Guide sleeves in the upper segment of the test fixture shall be in such a position as to direct the two loading strips together without appreciable binding or loose motion in the guide rods.

5.3 *Temperature Control System*—An air or water bath capable of maintaining the specimens at the specified test temperature within  $\pm 1.0$  °C.

5.4 *Thermometer*—A calibrated liquid-in-glass thermometer of suitable range with subdivisions readable to 0.1 °C or any other thermostatic device of equal accuracy, precision, and sensitivity shall be used. Thermometers shall conform to the requirements of Specification E1.

5.5 *Miscellaneous*—A tape, ruler, or set of calipers for specimen height measurement.

NOTE 2—If testing to determine the potential for moisture damage, the apparatus from Test Method D4867/D4867M or similar will also be necessary.

## 6. Specimens

6.1 *Laboratory-Molded Specimens*—Prepare the laboratory-molded specimens in accordance with one of the following standards: Test Methods D1074, D3387, D6925; Practices D1561/D1561M, D3496, D4013, D6926; and AASHTO T 245 or AASHTO T 312. A minimum specimen height of 50 mm is required for specimens with a nominal diameter of 100 mm. A minimum specimen height of 75 mm is required for specimens

with a nominal diameter of 150 mm. A minimum of three replicates shall be prepared for each mixture.

6.2 *Core Specimens*—Cores should have smooth surfaces and parallel faces, conforming to the height and diameter requirements specified for laboratory-molded specimens, except that a minimum height of 38 mm is permitted for specimens with a nominal diameter of 100 mm. A minimum of three replicates from an in-service pavement shall be prepared for testing.

NOTE 3—Specimens with a nominal diameter of 100 mm are suitable for mixtures with a nominal maximum particle size of 19 mm or less. Specimens with a nominal diameter of 150 mm are suitable for mixtures with a nominal maximum particle size of 37.5 mm or less.

## 7. Procedure

7.1 Determine the specimen height in accordance with Test Method D3549/D3549M, to the nearest 1 mm.

7.2 For core specimens, measure the diameter at the mid height along axes that are 90° apart, and record the average to the nearest 1 mm.

7.3 Bring the specimen to test temperature  $\pm 1$  °C by any of the following three alternative procedures. The recommended test temperature is 25 °C.

NOTE 4—Based on previous experience, a standard temperature that has been used for most IDT strength testing is 25 °C. Other test temperatures may be used at the discretion of the user.

7.3.1 *Procedure A*—Place the specimen in an air bath for a minimum of 4 h.

7.3.2 *Procedure B*—Place the specimen in a heavy duty leak-proof plastic bag and then place the specimen in a water bath for a minimum of 2 h.

7.3.3 *Procedure C*—Place the specimen in a water bath for a minimum of 30 min but not longer than 120 min.

7.4 Remove the specimen from the air or water bath, remove the specimen from the plastic bag (if necessary), and place onto the lower loading strip. Slowly lower the top loading strip to bring it into light contact with the specimen. Ensure that the loading strips are parallel and centered on the vertical diametral plane. The elapsed time between removal of test specimens from the bath and the final load determination shall not exceed 2 min.

7.5 Apply a vertical compressive ramp load until the maximum load is reached. The recommended deformation rate is  $50 \pm 5$  mm/min. Record the maximum load.

NOTE 5—This rate of loading has been commonly used for IDT strength specimens with a nominal diameter of 100 mm and is also recommended in Test Method D5581 when testing larger specimens for Marshall Stability with a nominal diameter of 150 mm. Research has not yet indicated if this deformation rate should be adjusted for IDT strength specimens with a nominal diameter of 150 mm. Some researchers<sup>5</sup> have also used a rate of 3.75 mm/min at higher temperatures (30 to 40 °C) on specimens with a nominal diameter of 150 mm to evaluate rutting potential.<sup>5</sup>

<sup>5</sup> Christensen, D. W., Bonaquist, R., and Jack, D. P., "Evaluation of Triaxial Strength as a Simple Test for Asphalt Concrete Rut Resistance," Pennsylvania Department of Transportation, Pennsylvania Transportation Institute, Final Report, August 2000.

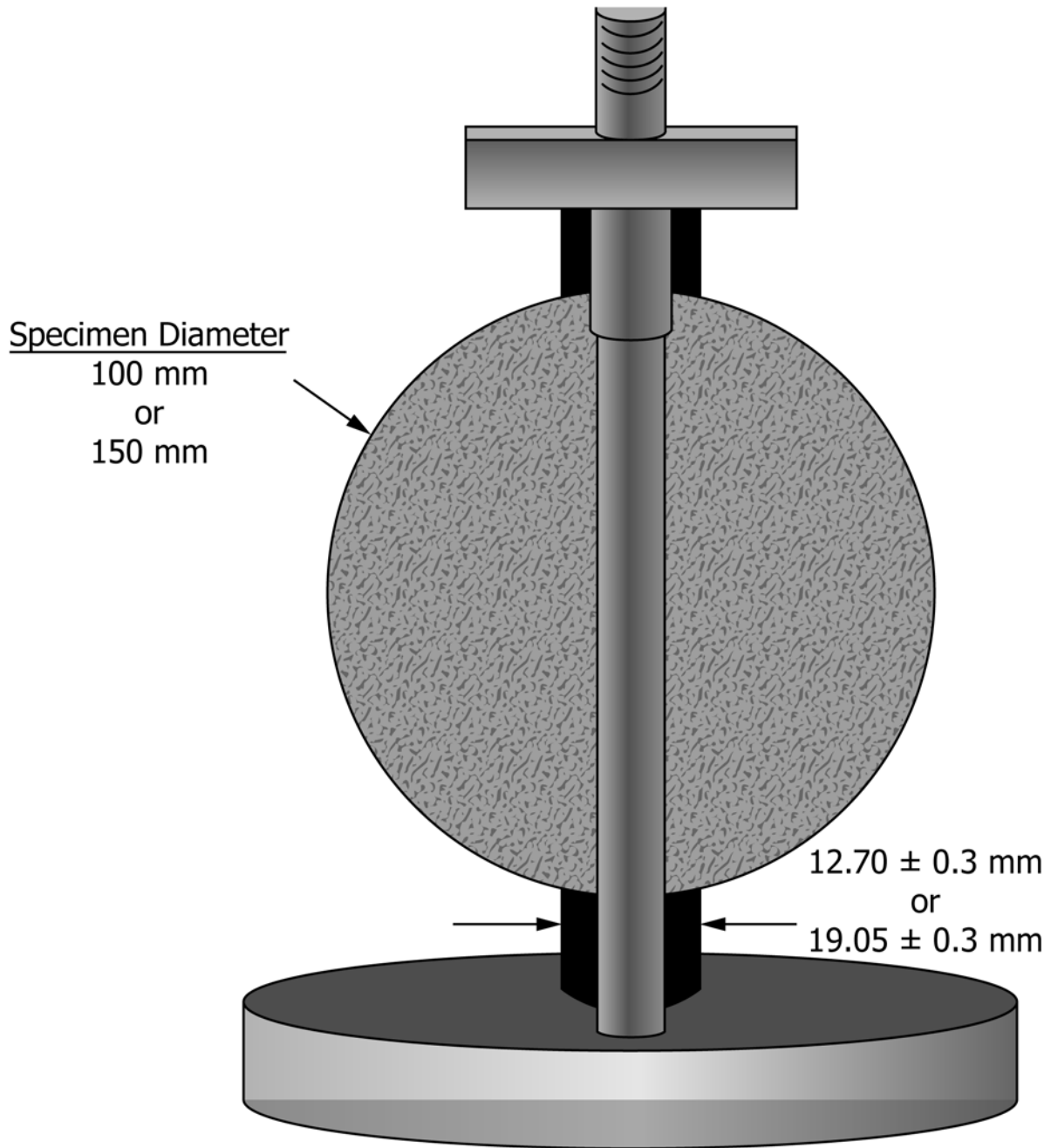

FIG. 1 Diagram of an IDT Strength-Loading Fixture

## 8. Calculation

8.1 Calculate the IDT strength as follows:

$$S_t = \frac{2000 \times P}{\pi \times t \times D} \quad (1)$$

where:

- $S_t$  = IDT strength, kPa,
- $P$  = maximum load, N,
- $t$  = specimen height immediately before test, mm, and
- $D$  = specimen diameter, mm.

## 9. Report

9.1 Report the following information:

- 9.1.1 Type of samples tested (laboratory-molded specimens or core specimens) and description of mixture (such as nominal maximum aggregate size, gradation, binder type).
- 9.1.2 The measured height and nominal (lab) or average (core) diameter of each specimen, to the nearest 1 mm.
- 9.1.3 Test temperature, to the nearest 1 °C.
- 9.1.4 Deformation rate used in test, to the nearest mm/min.

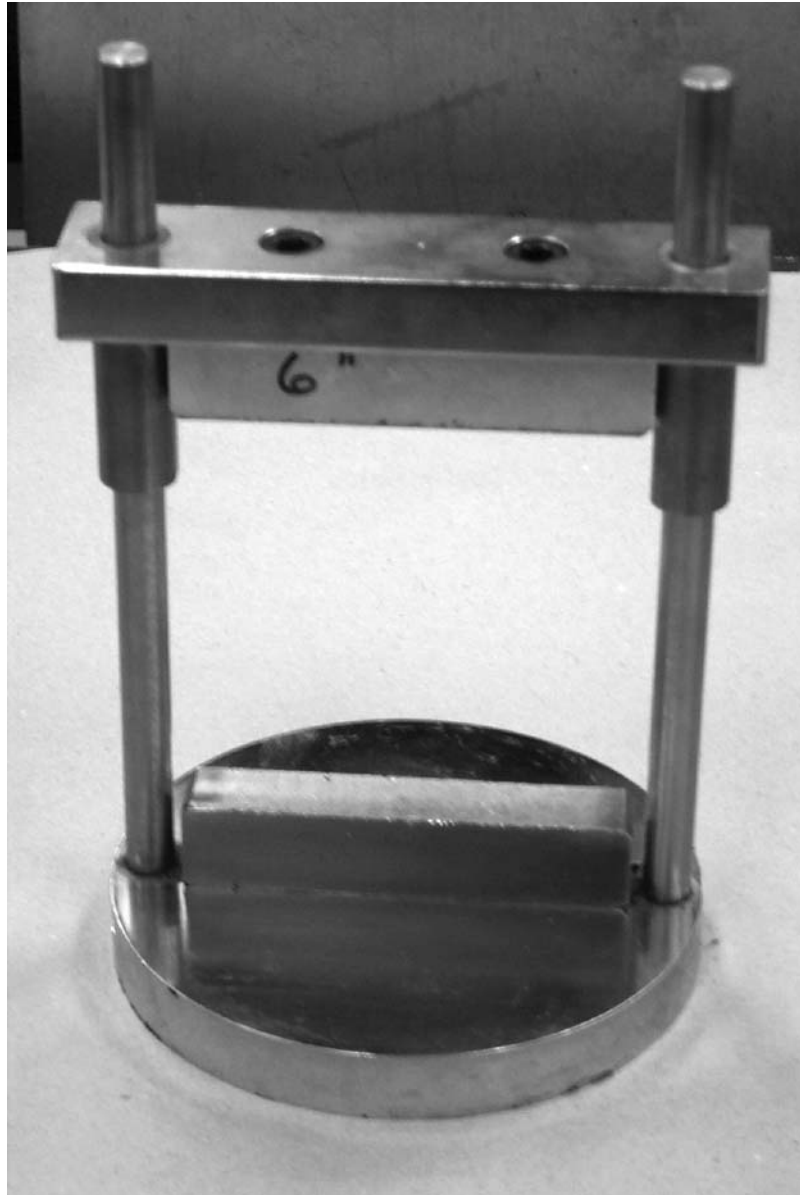

FIG. 2 Photograph of a Typical IDT Strength-Loading Fixture

9.1.5 Procedure used for conditioning specimen (as described in 7.3), including the method of temperature control and total bath time.

9.1.6 Maximum compressive load, to the nearest 1 N.

9.1.7 The IDT strength of each of the three replicate specimens and the average IDT strength for the set of specimens, to the nearest 10 kPa.

## 10. Precision and Bias

10.1 The within-laboratory repeatability standard deviation, for the recommended rate of loading (50 mm/min) and test temperature (25 °C), has been determined to be 80 kPa for 100-mm diameter specimens, based on 28 labs using either two or four test replicates with eleven different mix samples.

Additional data is provided in Table 1 for the user's information. The between-laboratory reproducibility of this test method is being determined and will be available on or before June 2018. Therefore, this standard should not be used for acceptance or rejection of materials for purchasing purposes.

10.2 No information can be presented on the bias of the procedure in this test method for measuring the tensile strength of asphalt mixtures, because it is a destructive test and there is no basis for establishing a true reference value for comparison.

## 11. Keywords

11.1 asphalt mixture; IDT; indirect tensile strength

**TABLE 1 Single-Laboratory Repeatability and Reproducibility**

Source of Data	Number of Replicates	Specimen Diameter (mm)	Loading Rate (mm/min)	Test Temperature (°C)	Average Strength (kPa)	Standard Deviation Strength (kPa)	d2s (2.83×SE) (kPa)	Standard Deviation Strength (% mean)	d2s (2.83×SE) (% mean)
Anderson and McGennis <sup>A</sup>	3	150	12.5	-10	2870	200	566	7.0	19.8
N CHRP Report 530 <sup>B</sup>	3	150	12.5	-10	-	-	-	9	22 – 32
(4 aggregate types; 4 binders)	2	150	12.5	-10	-	-	-	11	
(nom max size: 9.5 mm to 25 mm)									
Solaimanian and Kennedy <sup>C</sup> – dry	4	100	50	25	-	103	292	-	-
moisture-conditioned			50	25	-	83	234	-	-
(9 labs; 3 aggregate types; 2 binders)									
Test Method D4867/D4867M (dry or conditioned)	2	100	50	25	-	55	159	-	-
(19 labs; 5 mixtures)									
Suggested Single Lab Precision			50	25		80			

<sup>A</sup> R. M. Anderson and R. B. McGennis, "Ruggedness Evaluation of AASHTO TP7 and TP9," Phase I, FHWA HIPT (Task J), Federal Highway Administration, November 1998.

<sup>B</sup> W. Christensen and R. F. Bonaquist, "Evaluation of Indirect Tensile Test (IDT) Procedures for Low-Temperature Performance of Hot Mix Asphalt," NCHRP Report 530.

<sup>C</sup> Solaimanian and T. W. Kennedy, "Precision of the Moisture Susceptibility Test Method TEX-531-C," Project Summary Report 4909-S, November 2000.

*ASTM International takes no position respecting the validity of any patent rights asserted in connection with any item mentioned in this standard. Users of this standard are expressly advised that determination of the validity of any such patent rights, and the risk of infringement of such rights, are entirely their own responsibility.*

*This standard is subject to revision at any time by the responsible technical committee and must be reviewed every five years and if not revised, either reapproved or withdrawn. Your comments are invited either for revision of this standard or for additional standards and should be addressed to ASTM International Headquarters. Your comments will receive careful consideration at a meeting of the responsible technical committee, which you may attend. If you feel that your comments have not received a fair hearing you should make your views known to the ASTM Committee on Standards, at the address shown below.*

*This standard is copyrighted by ASTM International, 100 Barr Harbor Drive, PO Box C700, West Conshohocken, PA 19428-2959, United States. Individual reprints (single or multiple copies) of this standard may be obtained by contacting ASTM at the above address or at 610-832-9585 (phone), 610-832-9555 (fax), or service@astm.org (e-mail); or through the ASTM website (www.astm.org). Permission rights to photocopy the standard may also be secured from the Copyright Clearance Center, 222 Rosewood Drive, Danvers, MA 01923, Tel: (978) 646-2600; http://www.copyright.com/*