



Standard Test Method for Evaluating Diesel Fuel Lubricity by an Injection Pump Rig¹

This standard is issued under the fixed designation D6898; the number immediately following the designation indicates the year of original adoption or, in the case of revision, the year of last revision. A number in parentheses indicates the year of last reapproval. A superscript epsilon (ϵ) indicates an editorial change since the last revision or reapproval.

INTRODUCTION

All diesel fuel injection equipment relies, to some extent, on diesel fuel as a lubricant. Shortened life of diesel fuel injection pumps and injectors from wear caused by excessive friction has sometimes been ascribed to lack of lubricity in the fuel. This test assesses the lubricity of a fuel by operation of the fuel in a typical fuel injection system comprised of injection pump, high pressure pipes, and injectors on a pump test rig bench. The test models an actual commercial application of such equipment. The pump performance is evaluated on a test bench meeting SAE J1668 requirements.

1. Scope

1.1 This test method covers evaluating the lubricity of diesel fuels using a pump rig test and Stanadyne Model DB4427-4782 pumps.

NOTE 1—Other pumps may be used if a correlation between pump performance factors and fuel lubricity has been developed.

1.2 This test method is applicable to any fuel used in diesel engines, including those which may contain a lubricity enhancing additive.

1.3 The values stated in SI units are to be regarded as standard. No other units of measurement are included in this standard.

1.4 *This standard does not purport to address all of the safety concerns, if any, associated with its use. It is the responsibility of the user of this standard to establish appropriate safety and health practices and determine the applicability of regulatory limitations prior to use.* Specific warning statements are given in Section 7.

2. Referenced Documents

2.1 ASTM Standards:²

[D329 Specification for Acetone](#)

[D362 Specification for Industrial Grade Toluene \(Withdrawn 1989\)³](#)

[D4057 Practice for Manual Sampling of Petroleum and Petroleum Products](#)

[D4177 Practice for Automatic Sampling of Petroleum and Petroleum Products](#)

[D4306 Practice for Aviation Fuel Sample Containers for Tests Affected by Trace Contamination](#)

[D6078 Test Method for Evaluating Lubricity of Diesel Fuels by the Scuffing Load Ball-on-Cylinder Lubricity Evaluator \(SLBOCLE\)](#)

[D6079 Test Method for Evaluating Lubricity of Diesel Fuels by the High-Frequency Reciprocating Rig \(HFRR\)](#)

2.2 SAE Standards:⁴

[SAE J967 Calibration Fluid for Diesel Injection Equipment](#)
[SAE J968/1 Diesel Injection Pump Testing—Part 1: Calibrating Nozzles and Holder Assemblies](#)

[SAE J1418 Fuel Injection Pumps—High Pressure Pipes \(Tubing\) for Testing](#)

[SAE J1668 Diesel Engines—Fuel Injection Pump Testing](#)

3. Terminology

3.1 Definitions of Terms Specific to This Standard:

3.1.1 *boundary lubrication, n*—a condition in which the friction and wear between two surfaces in relative motion are determined by the properties of the surfaces and the properties of the contacting fluid, other than bulk viscosity.

3.1.1.1 *Discussion*—Metal to metal contact occurs and the chemistry of the system is involved. Physically adsorbed or

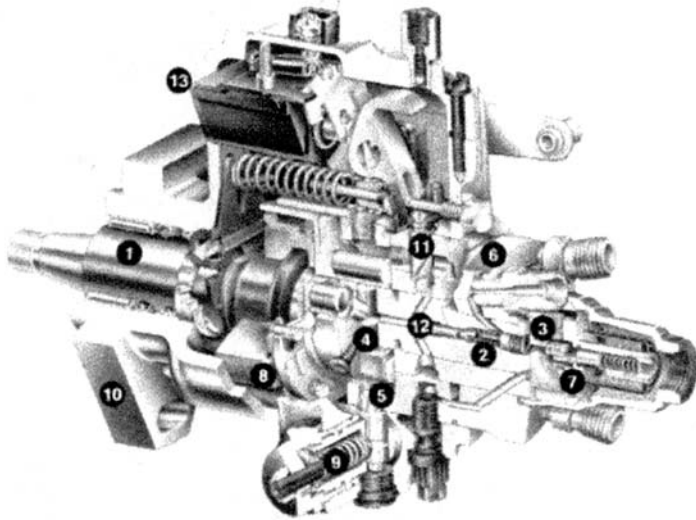
¹ This test method is under the jurisdiction of ASTM Committee D02 on Petroleum Products, Liquid Fuels, and Lubricants and is the direct responsibility of Subcommittee D02.E0 on Burner, Diesel, Non-Aviation Gas Turbine, and Marine Fuels.

Current edition approved Nov. 1, 2016. Published November 2016. Originally approved in 2003. Last previous edition approved in 2010 as D6898 – 03 (2010). DOI: 10.1520/D6898-03R16.

² For referenced ASTM standards, visit the ASTM website, www.astm.org, or contact ASTM Customer Service at service@astm.org. For *Annual Book of ASTM Standards* volume information, refer to the standard's Document Summary page on the ASTM website.

³ The last approved version of this historical standard is referenced on www.astm.org.

⁴ Available from SAE International (SAE), 400 Commonwealth Dr., Warrendale, PA 15096, <http://www.sae.org>.



1. Drive Shaft
2. Distributor Rotor
3. TP Blades
4. Pumping Plungers (4)
5. Internal Cam Ring
6. Hydraulic Head
7. Pressure Regulator Assembly
8. Governor
9. Automatic Advance
10. Housing
11. Metering Valve
12. Delivery Valve
13. Electric Shutoff Solenoid

Trademark of STANADYNE Diesel Systems

FIG. 1 Schematic of Stanadyne Model DB4427-4782 Pump

chemically reacted soft films (usually very thin) support contact loads. Consequently, some wear is inevitable.

3.1.2 *lubricity, n*—a qualitative term describing the ability of a fluid to affect friction between, and wear to, surfaces in relative motion under load.

3.1.2.1 *Discussion*—In this test method, the lubricity of a fluid is evaluated by comparing critical pump component dimensions, fuel flow rate and transfer pump pressures before and after testing under defined and controlled conditions. A computed value known as pump lubricity value (PLV) results.

3.1.3 *roller-to-roller (R-R), n*—a linear measurement of opposing pumping plungers in an injection pump when pressurized to force the plungers outward against the adjustable stop mechanism.

3.1.4 *transfer pump (TP), n*—a vane type low pressure supply pump internal to an injection pump.

4. Summary of Test Method

4.1 Prior to the start of the 500 h test, the roller-to-roller (R-R) dimension and transfer pump (TP) blade thickness are measured on two new or rebuilt pumps. The fuel flow ($\text{mm}^3/\text{stroke}$) and TP pressure (kPa) of each pump are measured at 100 r/min increments from 1000 r/min to 2200 r/min.

4.2 The pumps are mounted on the test bench and a thorough flushing process is performed. The test fuel(s) are stored in epoxy-lined containers (55 U.S. gal drums are suitable) which are plumbed to the test bench.

4.3 The pumps are operated at 1100 r/min for 500 h at the specified test conditions.

4.4 The pumps are removed from the test bench and the pre-test measurements are repeated.

4.5 The pre- and post- test data are used to compute the pump lubricity value (PLV).

5. Significance and Use

5.1 Diesel fuel injection equipment has some reliance on lubricating properties of the diesel fuel. Shortened life of engine components, such as diesel fuel injection pumps and injectors, has sometimes been ascribed to lack of lubricity in a diesel fuel.

5.2 Pump Lubricity Value (PLV) test results generally rank fuel effects on diesel injection system pump component distress due to wear in the same order as Bosch, Lucas, Stanadyne, and Cummins in-house rig tests.⁵ In these fuel/hardware tests, boundary lubrication is believed to be a factor in the operation of the component.

5.3 The PLV is sensitive to contamination of the fluids and test materials and the temperature of the test. Lubricity evaluations are also sensitive to trace contaminants acquired during test fuel sampling and storage.

5.4 Test Methods D6078 and D6079 are two methods for evaluating diesel fuel lubricity. No absolute correlation has been developed between these two test methods, or between either of these methods and the PLV.

5.5 The PLV may be used to evaluate the relative effectiveness of a fluid for preventing wear under the prescribed test conditions.

5.6 This test method is designed to evaluate boundary lubrication properties. While viscosity effects on lubricity are not totally eliminated, they are minimized.

5.7 This test can indicate whether or not an additive will improve the lubricity of a poor lubricity fuel.

⁵ Nikanjam, M., Crosby, T., Henderson, P., Gray, C., Meyer, K., and Davenport, N., "ISO Diesel Fuel Lubricity Round Robin Program," SAE Paper 952372, Oct. 16-19, 1995.

TEST STAND: ISO 4008:

1. CALIBRATING HIGH PRESSURE PIPES...SAE J1418/ISO 4093: .063" (1.6 mm) I.D. x 25" (635 mm) LONG.
2. CALIBRATING INJECTORS... SAE J968/ISO 7440: 0.5 mm ORIFICE PLATE NOP: 3000 PSI (207 BAR).
3. CALIBRATION FLUID...SAE J967/ISO 4113 (REF. S.B. 201):
 - a. TEMPERATURE AT INLET 110°–115°F (43°–46°C)
 - b. SUPPLY PRESSURE (S.B. 334): 2.0 ± 0.5 PSI. (14 ± 3 kPa) AT PUMP INLET.
4. CAM MOVEMENT READ-OUT DEVICE: #23745.

PUMP INSTALLATION: IT-013

ROTATION-C*	LEVER ANGLES (REF.)
NAME PLATE-L-SIDE**	THOT MIN. (L/B) N/A
#1 CYL.-5-O'CLOCK**	THOT MAX. (L/C) N/A
THROTTLE-R-SIDE**	S.O. (L/E) N/A
TIMING MARK 131.5°	S.O. (L/F) N/A
E.S.O. (12V E.T.R.)	

*VIEWED FROM DRIVE END **VIEWED FROM TRANSFER PUMP END

PUMP OPERATING SPEED...HALF...ENGINE SPEED
AIR TIMED TO HOUSING FLANGE (SEE SPECIAL NOTES)
MECHANICALLY TIMED TO CAM (REF. S.B. 177)

PUMP CALIBRATION CHECKS: AS RECEIVED FOR SERVICE
(REF. SL-222)

1. **1000 RPM WOT:** OPERATE PUMP FOR 10 MINUTES TO BRING TO OPERATING TEMPERATURE AND CLEAR AIR FROM SYSTEM.
2. **2420 RPM (WOT):** RESET HIGH IDLE SCREW IF NECESSARY TO OBTAIN 10–12 mm³/STROKE.
3. **CHECK POINTS:** (SEQUENCE MUST BE FOLLOWED AS LISTED)

RPM	THROTTLE POSITION	mm ³ /STROKE	ADVANCE
a. 150	WOT	35 MIN.	---
b. 400	WOT*	4 MAX.	---
c. 850	L.I.**	10–12	---
d. 1200	WOT	---	2.0°–4.0°
e. 1500	WOT	74–80	5.0°–7.0°
f. 2200	WOT	67.5–71.5	7.5°–8.5°
g. 2200	WOT*	4 MAX.	---
h. 2420	WOT	10–12	---
i. 2470	WOT	5 MAX.	---

* E.S.O. DE-ENERGIZED
** RESET USING LOW IDLE SCREW, IF NECESSARY

PUMP SETTINGS: FOLLOWING PUMP SERVICE

1. ROLLER-TO-ROLLER DIMENSION... 1.958" ± .001"
(49.72 mm ± 0.04 mm)
MAXIMUM ECCENTRICITY: .004" (0.10 mm) T.I.R.
2. GOVERNOR LINKAGE GAP: .125"–.165" (3.2–4.2 mm)
(USE KIT #23093 S.B. 95)
3. **1000 RPM (WOT):** OPERATE PUMP FOR 10 MINUTES TO BRING TO OPERATING TEMPERATURE AND CLEAR AIR FROM SYSTEM.
4. **400 RPM (WOT):**
 - a. CHECK SHUT-OFF: 4 mm³/STROKE, MAX.
 - b. CHECK FOR MINIMUM TRANSFER PUMP LIFT OF 18" HG. (60 kPa)
5. **2200 RPM (WOT):**
 - a. SET TRANSFER PUMP PRESSURE 84-86 PSI, (580–593 kPa)(SUPPLY SET PER TEST STAND NOTE 3B)
 - b. ADJUST RETURN OIL TO 200–500 CC/MIN. RECHECK TRANSFER PUMP PRESSURE.
 - c. CHECK HOUSING PRESSURE FOR 4–8.5 PSI, (28–59 kPa).
6. **1500 RPM (WOT):** SET ADVANCE TRIMMER SCREW FOR 6.0°.
7. **2200 RPM (WOT):** SET ROLLER-TO-ROLLER FUEL DELIVERY: 69–70 mm³/STROKE.
8. **2420 RPM (WOT):** ADJUST HIGH IDLE SCREW TO OBTAIN 10–12 mm³/STROKE.
9. **850 RPM (L.I.):**
 - a. SET THROTTLE LEVER STOP SCREW FOR 10–12 mm³/STROKE, THEN BACK OUT 2 FULL TURNS AND LOCK.
 - b. SET LOW IDLE SCREW (COVER) FOR 10–12 mm³/STROKE.
10. **CHECK POINTS:**

	RPM PRESSURE	THROTTLE POSITION	mm ³ /STROKE	ADVANCE	T.P.
a.	150	WOT	36 MIN.	---	10 MIN.**
b.	400	WOT*	4 MAX.	---	---
c.	850	L.I.	10–12	---	---
d.	1200	WOT	---	2.0°–4.0°	---
e.	1500	WOT	75–79	5.5°–6.5°	---
f.	2200	WOT	69–70	7.5°–8.5°	84–86***
g.	2200	WOT*	4 MAX.	---	---
h.	2420	WOT	10–12	---	---
i.	2470	WOT	5 MAX.	---	---

* E.S.O. DE-ENERGIZED ** (69 kPa) *** (580–593 kPa)

11. **SPECIAL NOTES:**
 - a. TORQUE ALL FASTENERS PER S.B. 106.
 - b. ELECTRIC SHUT-OFF TO BE CHECKED PER S.B. 108.
 - c. ASSEMBLE THROTTLE LEVER SPACER AND ARM IN B4-L POSITION PER S.B. 164.
 - d. ASSEMBLE DRIVE COMPONENTS PER S.B. 438.
 - e. SEAL FASTENERS PER S.B. 134.
12. **FOR SERVICE ONLY:**
AIR TIME PUMP USING HARTRIDGE BASIC AIR TIMING TOOL 7244-27 WITH INSERT 7244-30 AND PILOT RING 7244-26E. CONNECT AIR SUPPLY WITH 60–100 PSI (4.1–6.9 BAR) TO #1 CYLINDER OUTLET. SET TOOL TO 105° AND INSTALL TO DRIVE SHAFT. SLOWLY ROTATE TOOL CLOCKWISE UNTIL ROLLERS STRIKE CAM AND TOOL STOPS, SCRIBE LINE ON HOUSING FLANGE. REPEAT PROCEDURE TO ENSURE ACCURACY. IF INTERFERENCE BETWEEN STRAIGHT EDGE AND HOUSING FLANGE OCCURS, PLACE WASHER (i.e. 13521) BETWEEN STRAIGHT EDGE AND TOOL.

Trademark of STANADYNE Diesel Systems
All speeds are in engine r/min unless otherwise noted.
Use latest revision for all Referenced Documents.

FIG. 2 Injection Pump Specification (Service/Assembly) Model No.: DB4427-4782

6. Apparatus

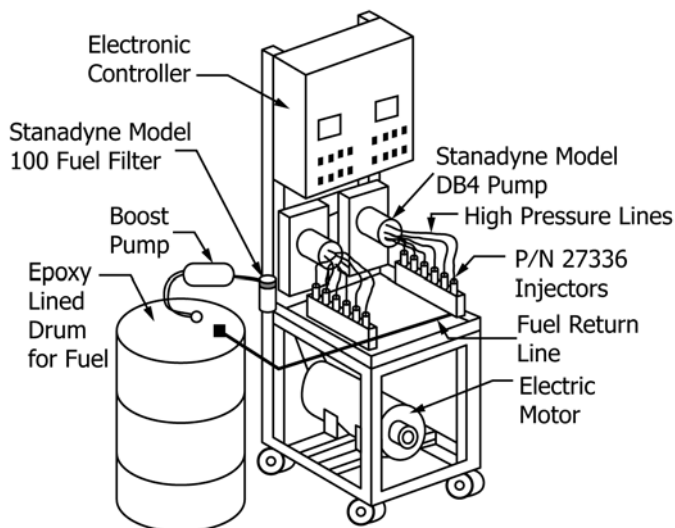
6.1 *Test Pumps*—The test pumps are Stanadyne 4-cylinder model DB4427-4782 pump⁶ (see Fig. 1). Providing they meet the Stanadyne DB4427-4782 specifications (see Fig. 2), the pumps can be new or rebuilt. The test pump must always use new head and rotor, and TP assemblies. While a single pump can be tested, the preferred method is to test two pumps simultaneously with the same test fuel.

⁶ The sole source of supply of the pumps known to the committee at this time is Stanadyne Automotive Corp., 92 Deerfield Rd., Windsor, CT 06095-2409, or a registered service dealer. If you are aware of alternative suppliers, please provide this information to ASTM International Headquarters. Your comments will receive careful consideration at a meeting of the responsible technical committee¹, which you may attend.

6.2 *Performance Test Bench*—An SAE J1668 test bench is used for performance testing of each test pump.

6.3 *Calibrating Injector*—A calibrating nozzle and holder assembly with a single hole orifice plate, in accordance with SAE J968/1, is used for performance testing of each test pump.

6.4 *Pump Test Rig*—The pump test rig consists of an electric motor driven test bench capable of driving two test pumps simultaneously at a specified speed (see Fig. 3). The test rig is equipped with stainless steel low pressure piping with fuel inlet pipes from a drum of test fuel. Boost pumps in the inlet lines pump fuel through fuel filters to the inlet of the test pumps. Fuel is discharged from the test pumps through specified inside diameter and length high pressure pipe, to the specified injectors. The injectors are housed in accumulators to collect



NOTE 1—The system shown in this figure is a six-cylinder (six injectors) pump, while the test pump (see 6.1) is a four-cylinder application.

FIG. 3 Test Rig Portable Bench

the discharged fuel and return it to the drum. Thus the fuel system is closed and the fuel continuously recirculates. The test rig is operated in a room with an ambient temperature of $24 \text{ }^\circ\text{C} \pm 3 \text{ }^\circ\text{C}$.

6.5 *Electric Motor*, an adjustable speed motor capable of producing speeds to 1500 r/min and a torque of 122 N-m.

6.6 *Low Pressure Piping*, 9.5 mm inside diameter stainless steel tubing of whatever length is needed for the application.

6.7 *Boost Pumps*, pumps which operate at 14 kPa to 34 kPa and pump 76 L/h to 114 L/h.

6.8 *Fuel Filters*, Stanadyne model 100⁷ or John Deere RF 624118.

6.9 *Filter Head/Fuel Handler*, Stanadyne 33260⁷ for attachment of fuel filters.

6.10 *High Pressure Pipes*—HP pipes in accordance with SAE J1418 are 1.6 mm \pm 0.025 mm inside diameter \times 640 mm \pm 5 mm long with a nominal outside diameter of 6 mm and a minimum central line bend radius of 16 mm for both the performance testing and the test rig testing.

NOTE 2—SAE J1418 specifies the length of this tubing as 600 mm \pm 5 mm but 640 mm is required in these applications.

6.11 *Test Rig Injectors*—The test rig injectors are Stanadyne p/n 27336⁷ (see Fig. 4). These injectors are known as *engine injectors* as compared to *calibrating injectors*.

6.12 *Accumulator*, a stainless steel box, into which the injectors are screwed, that has a line to return the injected fuel back to the drum (see Fig. 5).

6.13 *Micrometer*, 25.4 mm to 50.8 mm with a resolution of 0.001 mm and an accuracy of 0.003 mm to measure the R-R dimension.

6.14 *Point Micrometer*, 0 mm to 25.4 mm with a resolution of 0.001 mm and an accuracy of 0.003 mm to measure the thickness of the TP blades.

6.15 *R-R Setting Fixture*, a special tool available from Stanadyne.⁷

6.16 *Electronic Control Unit*, any commercially available unit capable of operating the test rig.

6.17 *Tachometers*, used to measure the r/min of the test pumps.

6.18 *Thermocouples*, used to measure air temperature, and fuel temperatures in the drum, after the boost pump, after the DB4427-4782 pumps, and in the fuel return lines.

6.19 *Pressure Transducers*, used to measure the pressure after the boost pump and after the DB4427-4782 pumps.

6.20 *Flow Meters*, used to measure the fuel flow through the DB4427-4782 pumps.

6.21 *Level Sensor*, used to monitor the level of fuel in the drum.

6.22 *Hydrocarbon Gas Detector*, used to monitor for potentially explosive vapors in the room.

6.23 *Flushing Adapters*, necessary fittings and adapters to bypass the fuel filter, connect the fuel pump inlet directly to the HP pipes, and connect the HP pipes to the accumulator. These adapters are used to flush the test rig between fuel tests.

7. Reagents and Materials

7.1 *Acetone*, conforming to Specification D329. (**Warning**—Extremely flammable. Vapors may cause flash fire.)

7.2 *Calibration Fluid*, a fluid formulated from refined and deodorized fuel stocks, meeting SAE J967 specifications, used for pump performance testing.

7.3 *Compressed Air*, containing less than 0.1 ppmv hydrocarbons and 50 ppmv water. (**Warning**—Compressed gas under high pressure. Use with extreme caution in the presence of combustible material.)

7.4 *Flushing Fluid*, 75/25 mixture of toluene and acetone used to flush the pump test rig between fuel tests.

7.5 *Toluene*, conforming to Specification D362. (**Warning**—Flammable. Harmful if inhaled.)

8. Sampling and Sample Containers

8.1 Unless otherwise specified, take samples by the procedure described in Practice D4057 or Practice D4177.

8.2 Because of the sensitivity of lubricity measurements to trace materials, sample containers shall be only fully epoxy-lined metal drums, cleaned and rinsed thoroughly at least three times with the product to be sampled before use, as specified in Practice D4306.

8.3 New sample containers are preferred, but if not available, Practice D4306 gives guidance on suitable cleaning procedures.

⁷ Available from Stanadyne Automotive Corp., 92 Deerfield Rd., Windsor, CT 06095-2409, or a registered service dealer.

EDITION : 8
 ENGINE MODEL NO: 300 SERIES TC
 DATED: 03-16-2000
 CUSTOMER: JOHN DEERE
 TEST STAND: ISO 8984

ASSEMBLY NO: 27336
 SUPERSEDES: 22264
 CUSTOMER PART NO: AR-90024

NOTE: Reference Pencil Nozzle Service

1. CALIBRATION FLUID...SAE J967 / ISO 4113
 (Ref. S.B. 201) AT ROOM TEMPERATURE (70°-80° F)
2. CALIBRATION HIGH PRESSURE PIPES..0.063 × 12"
 (1.6 × 305 mm)

Manual 99002 and S.B. 467 for additional service information.

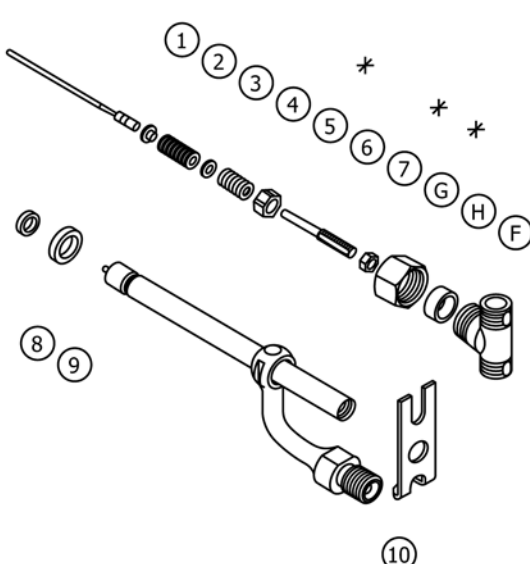
<p>INJECTOR SETTINGS</p> <p>1. OPENING PRESSURE SETTINGS:</p> <table style="width: 100%; border-collapse: collapse;"> <thead> <tr> <th style="width: 15%;"></th> <th style="width: 35%; text-align: center;">SET</th> <th style="width: 50%; text-align: center;">CHECK</th> </tr> </thead> <tbody> <tr> <td>** NEW</td> <td style="text-align: center;">3820 ± 40 PSI (263.5 ± 2.8 bar)</td> <td style="text-align: center;">3740 PSI MIN. (257.5 bar)</td> </tr> <tr> <td>SERVICE</td> <td style="text-align: center;">3620 ± 40 PSI (249.5 ± 2.8 bar)</td> <td style="text-align: center;">3410 PSI MIN. (235 bar)</td> </tr> </tbody> </table> <p>2. VALVE LIFT: TURN 3/4 ± 1/8 .135 (0.34 mm) NOMINAL 3. SPRAY ORIFICE SIZE: .0116 (0.29 mm) 4. SPRAY ORIFICE NUMBER: 4 5. SAC TYPE: .0394 METRIC 6. CHECK NOZZLE "CHATTER" PER PENCIL NOZZLE SERVICE MANUAL 99002. IF ACCEPTABLE PROCEED TO STEP 7. 7. RETURN OIL LEAKAGE: 1 TO 14 DROPS / 30 SECONDS MAX. AT 1500 PSI (SERVICE ONLY).</p> <p>** SETTINGS FOR NEW NOZZLE OR WHEN A NEW PRESSURE ADJUSTING SPRING IS USED.</p>		SET	CHECK	** NEW	3820 ± 40 PSI (263.5 ± 2.8 bar)	3740 PSI MIN. (257.5 bar)	SERVICE	3620 ± 40 PSI (249.5 ± 2.8 bar)	3410 PSI MIN. (235 bar)	<p>THE FOLLOWING ITEMS USED IN CONJUNCTION WITH THE NOZZLE ASSEMBLY ARE PURCHASED SEPARATELY:</p> <p>A. PROTECTIVE SHIPPING CAPS NO. 16560 & 18964 B. NOZZLE CLAMP ASSEMBLY NO. 22999 C. NOZZLE CLAMP ASSEMBLY SPACER NO. 20629 D. FUEL LINE CONNECTOR NUT NO. 16164 E. FUEL LINE FERRULE NO. 16166 F. NOZZLE LEAK-OFF CAP NO. 31286 G. NOZZLE LEAK-OFF NUT NO. 24187 * H. NOZZLE LEAK-OFF GROMMET NO. 17721</p> <p>* ASSEMBLY TORQUE: 24185 70-80 lbf-in (7.9-9.0 N-m) 24186 35-45 lbf-in (4.0-5.1 N-m) 24187 20-30 lbf-in (2.3-3.4 N-m)</p> <p>*** REPLACE AS A SET</p>																																			
	SET	CHECK																																											
** NEW	3820 ± 40 PSI (263.5 ± 2.8 bar)	3740 PSI MIN. (257.5 bar)																																											
SERVICE	3620 ± 40 PSI (249.5 ± 2.8 bar)	3410 PSI MIN. (235 bar)																																											
	<table border="1" style="width: 100%; border-collapse: collapse;"> <thead> <tr> <th style="width: 10%;">ITEM NO.</th> <th style="width: 15%;">PART NO.</th> <th style="width: 10%;">QTY REQ.</th> <th style="width: 65%;">DESCRIPTION</th> </tr> </thead> <tbody> <tr> <td>1</td> <td>28753***</td> <td>1</td> <td>SEAT, spring</td> </tr> <tr> <td>2</td> <td>28071</td> <td>1</td> <td>SPRING, pressure adjusting</td> </tr> <tr> <td>3</td> <td>20742</td> <td>1</td> <td>SHIM, pressure adjusting</td> </tr> <tr> <td>4</td> <td>23705</td> <td>1</td> <td>SCREW, pressure adjusting</td> </tr> <tr> <td>5</td> <td>24185*</td> <td>1</td> <td>LOCKNUT, pressure screw</td> </tr> <tr> <td>6</td> <td>30609***</td> <td>1</td> <td>SCREW, lift adjusting</td> </tr> <tr> <td>7</td> <td>24186*</td> <td>1</td> <td>LOCKNUT, lift screw</td> </tr> <tr> <td>8</td> <td>16389</td> <td>1</td> <td>SEAL, carbon stop</td> </tr> <tr> <td>9</td> <td>20628</td> <td>1</td> <td>WASHER, plain</td> </tr> <tr> <td>10</td> <td>24188</td> <td>1</td> <td>PLATE, injector locating</td> </tr> </tbody> </table>	ITEM NO.	PART NO.	QTY REQ.	DESCRIPTION	1	28753***	1	SEAT, spring	2	28071	1	SPRING, pressure adjusting	3	20742	1	SHIM, pressure adjusting	4	23705	1	SCREW, pressure adjusting	5	24185*	1	LOCKNUT, pressure screw	6	30609***	1	SCREW, lift adjusting	7	24186*	1	LOCKNUT, lift screw	8	16389	1	SEAL, carbon stop	9	20628	1	WASHER, plain	10	24188	1	PLATE, injector locating
ITEM NO.	PART NO.	QTY REQ.	DESCRIPTION																																										
1	28753***	1	SEAT, spring																																										
2	28071	1	SPRING, pressure adjusting																																										
3	20742	1	SHIM, pressure adjusting																																										
4	23705	1	SCREW, pressure adjusting																																										
5	24185*	1	LOCKNUT, pressure screw																																										
6	30609***	1	SCREW, lift adjusting																																										
7	24186*	1	LOCKNUT, lift screw																																										
8	16389	1	SEAL, carbon stop																																										
9	20628	1	WASHER, plain																																										
10	24188	1	PLATE, injector locating																																										
<p>FOR ENGINEERING USE ONLY</p> <table style="width: 100%; border-collapse: collapse;"> <thead> <tr> <th style="width: 30%;">DATE</th> <th style="width: 30%;">ECN NO.</th> <th style="width: 40%;">EDITION</th> </tr> </thead> <tbody> <tr> <td>07-25-84</td> <td></td> <td>1</td> </tr> <tr> <td>08-22-84</td> <td>16374</td> <td>2</td> </tr> <tr> <td>09-13-84</td> <td>16405</td> <td>3</td> </tr> <tr> <td>10-11-88</td> <td>19016</td> <td>4</td> </tr> <tr> <td>12-08-88</td> <td>19321</td> <td>5</td> </tr> <tr> <td>09-28-94</td> <td>23243</td> <td>6</td> </tr> <tr> <td>07-10-95</td> <td>23898</td> <td>7</td> </tr> <tr> <td>03-16-00</td> <td>26746</td> <td>8</td> </tr> </tbody> </table>		DATE	ECN NO.	EDITION	07-25-84		1	08-22-84	16374	2	09-13-84	16405	3	10-11-88	19016	4	12-08-88	19321	5	09-28-94	23243	6	07-10-95	23898	7	03-16-00	26746	8																	
DATE	ECN NO.	EDITION																																											
07-25-84		1																																											
08-22-84	16374	2																																											
09-13-84	16405	3																																											
10-11-88	19016	4																																											
12-08-88	19321	5																																											
09-28-94	23243	6																																											
07-10-95	23898	7																																											
03-16-00	26746	8																																											

FIG. 4 Injector Specification

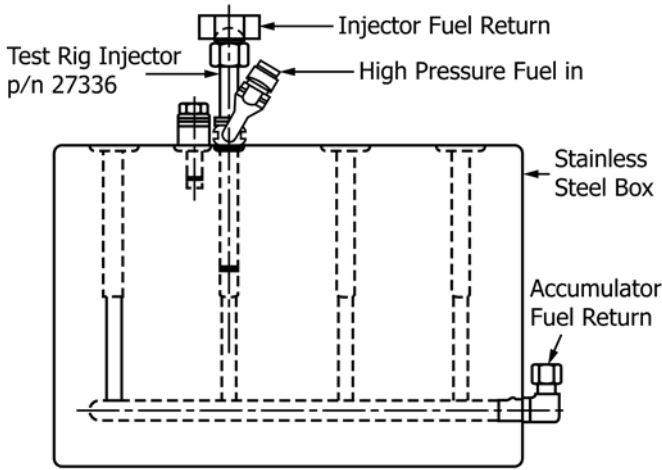


FIG. 5 Accumulator for Test Rig Injectors

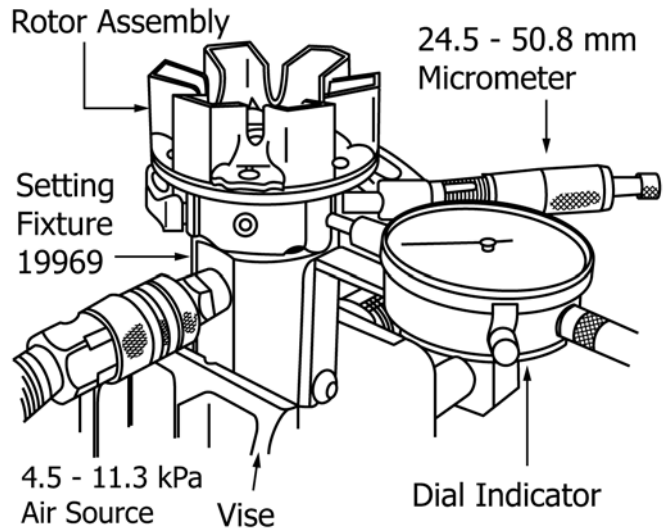


FIG. 6 Measurement of R-R Dimension

9. Preparation of Apparatus, Pumps, and Engine Injectors

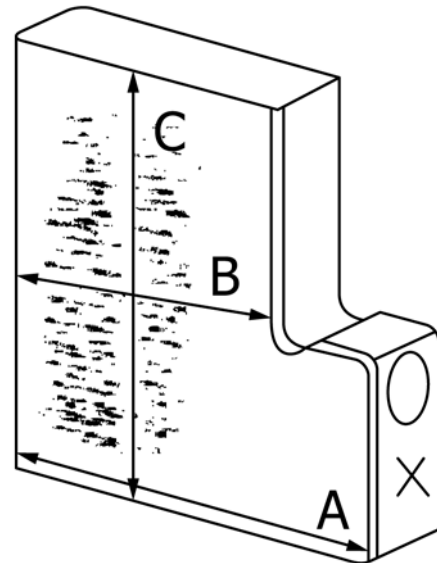
9.1 Disassemble a test pump in accordance with the instructions in Stanadyne Publication 99689 to permit measurement of the R-R dimension and the TP blade thickness.

9.2 Secure R-R setting fixture 19969 in vise and insert rotor assembly (see Fig. 6). Connect dry, clean, filtered compressed air source regulated to 4.5 kPa to 11.3 kPa to force the plungers outward until the shoes contact the leaf springs. Using the 25.4 to 50.8 micrometer, measure the distance between the outer surfaces of each pair of opposed rollers to the nearest 0.002 mm. The R-R dimension must be $49.73 \text{ mm} \pm 0.04 \text{ mm}$. The leaf spring adjusting screws can be turned clockwise to increase or counterclockwise to decrease the dimension. The two dimensions must be within 0.08 mm of each other and the average of the two dimensions must be within 0.04 mm of 49.73 mm.

9.2.1 Example—One pair of rollers measures 49.76 mm while the other measures 49.68 mm. The two dimensions are within 0.08 mm of each other and the average of the 2 dimensions, 49.72 is within 0.04 mm of 49.73 mm. If the R-R dimensions meet the above specifications, they are suitable for use in this test. Record the measured dimensions. If the dimensions do not meet the above specifications, new shoes will be required.

9.3 Using a point micrometer measure and record to the nearest 0.002 mm the thickness of the TP blades at three evenly spaced points along the center of the face of the blade (along line C in Fig. 7). If a blade thickness is $\leq 13.67 \text{ mm}$ thick, replace it with a new blade. Using a vibrating pencil (inscriber), place an identifying mark on each blade on the surface just under the spring hole (X in Fig. 7) for ease of identification during post-test measurements. Record the identifying mark for each blade with its thickness measurements.

9.4 Reassemble the test pump and mount it on the SAE J1668 test bench. Using the calibration fuel, conduct a performance test following the sequence under the heading “PUMP SETTINGS: FOLLOWING PUMP SERVICE:” in Fig. 2. If the specifications in Fig. 2 are not achieved, make adjustments in



Measure width at A, B, and C
Inscribe 1, 2, 3, or 4 at X

FIG. 7 TP Blade

accordance with instruction manual 99689, except do not readjust the R-R dimension. After successfully meeting the conditions of Fig. 2, record fuel flow and TP pressure at 100 r/min increments from 1000 r/min to 2200 r/min, and at 2290 r/min, 2380 r/min, and 2470 r/min. Use this data to develop a pre-test fuel flow and TP pressure versus r/min curve.

9.5 Remove the test pump from the test bench and drain all calibrating fluid from the pump.

9.6 Repeat the procedure in 9.1 – 9.5 for the second test pump.

9.7 Install the flushing adapters on the test rig bench such that the fuel circuit consists of boost pump inlet tube, boost pump, filter inlet tube, filter header with no filter (or a filter

used for flushing purposes only), fuel pump inlet, HP pipes, injector accumulator, and accumulator discharge tube.

9.8 Fill a container, such as a 10 L (2 U.S. gal) pail with a 75/25 mixture of toluene and acetone. Place the boost pump inlet tube to the bottom of this container and place the accumulator discharge tube into an empty pail.

9.9 Turn on the boost pump and pump the flushing fluid from the full pail to the empty pail. Turn off the boost pump.

9.10 Remove the flushing fluid pails and properly dispose of the flushing fluid. Remove the flushing adapters.

9.11 Repeat the steps in 9.6 – 9.10 for the second pump.

9.12 Check the pop-off pressure of each of the injectors. Any injectors with a pop-off pressure less than 235 bar, see Fig. 5, must be reconditioned or replaced.

9.13 Install new filters and mount a test pump into each pump mounting plate. Connect the boost pump outlet tube to the inlet side of each filter and fit a tube from each filter outlet to each injection pump inlet. Connect a tube from the return fitting on top of the test pump together with a tube connected to each injector return to the discharge fitting on the accumulator.

9.14 Place the fuel pickup tube half way down into the fuel drum. Place the return lines (pump return, injector returns, and accumulator discharge) into an empty pail.

9.15 Operate the test pumps at speeds less than 1000 r/min with the fuel lever in the low idle position. Pump nearly 5 gal of fuel through the systems to remove all the calibration fuel from the test pumps and all the flushing fluid from the lines. Stop the pumps and properly dispose of the fuel.

9.16 Replace the fuel pickup tube so that it is at a level approximately 25 mm below the top of the fuel.

NOTE 3—Placing the pickup tube near the top surface of the fluid minimizes the quantity of fuel that might spill from a leak prior to the rig shutting down due to a low pressure.

9.17 Place the fuel return lines into the drums with the discharge located approximately 13 mm from the bottom of the drums.

NOTE 4—Placing the fuel return discharge near the bottom of the drum ensures that over the course of the test the complete drum contents are pumped through the test rig.

10. Procedure

10.1 Draw a fuel sample from the drum and measure and record the lubricity of the test fuel in accordance with Test Method D6078 or in accordance with Test Method D6079 (at 60 °C).

10.2 Start the test pumps and set them to operate at 1100 r/min \pm 10 r/min with the fuel levers in the wide open throttle (WOT) position.

10.3 Hold the ambient air temperature to 24 °C \pm 3 °C.

10.4 Operate the test pump(s) on the test rig for 250 h.

10.5 Shut the pumps down and transfer the inlet and return fuel lines to a fresh drum of the test fuel. Draw fuel samples from the used and new drum and measure and record the

lubricity of the test fuel in accordance with Test Method D6078 or in accordance with Test Method D6079 (at 60 °C).

10.6 If the pre-test SLBOCLE and 250 h SLBOCLE differ by 900 g or more, or if the pre-test HFRR and 250 h HFRR differ by 0.08 mm or more, the lubricity of the fuel has changed substantially. Abort the test and obtain a new fuel sample before rerunning the test.

10.7 If the pre-test SLBOCLE and the new drum SLBOCLE differ by 900 g or more, or if the pre-test HFRR and new drum HFRR differ by 0.08 mm or more, the lubricity of the fuels in the two drums is substantially different. Abort the test and obtain a new fuel sample before rerunning the test.

10.8 Repeat the steps in 10.2 and 10.3.

10.9 At the end of the second 250 h period draw fuel samples from the drum and measure and record the lubricity of the test fuel in accordance with Test Method D6078 or in accordance with Test Method D6079 (at 60 °C).

10.10 If any of the SLBOCLEs differ by 900 g or more, or if any of the HFRRs differ by 0.080 mm or more, the lubricating properties of the fuel may have changed during the test, or the lubricating properties of the fuel in Drum 1 may be different than that in Drum 2. Note this observation when reporting the PLV.

10.11 If at any time during the test, the fuel level should drop below a specified level or the level of hydrocarbon vapors get to within 50 % of the lower explosive limit, the test should be shut down to investigate a possible fuel leak.

10.12 If a pump seizes before the completion of 500 h; disassemble the pump to analyze the failure. If the analysis indicates that the failure was due to lack of lubrication, assign a value of 10 for the test fuel PLV. A seizure at the TP end with some evidence of localized heat is a lack of lubrication seizure. A seizure at the drive end or at the rotor discharge port is due to misalignment or debris. In either of these cases report the apparent cause of the seizure but do not assign any value to the PLV.

NOTE 5—During the testing any portion of the pump test rig setup, except the test pumps, can be replaced if it fails for any reason.

NOTE 6—The maximum time that the pump test rig can be shut down during the 500 h of testing, without invalidating the test results, is 60 h.

10.13 Remove the test pumps from the test rig bench and drain all test fuel from the pumps.

10.14 Place one of the test pumps on the SAE J1668 test bench and repeat 9.4 except that the data recorded in 9.4 is used to develop a post-test fuel flow and TP pressure versus r/min curve.

10.15 Disassemble the test pump in accordance with the instructions in Stanadyne Publication 99689 to permit measurement of the R-R dimension and the TP blade thickness.

10.16 Secure R-R setting fixture 19969 in vise and insert rotor assembly (see Fig. 6). Connect a dry, clean, filtered compressed air source, regulated to 4.5 kPa to 11.3 kPa, to force the plungers outward until the shoes contact the leaf springs. Using the 25.4 to 50.8 micrometer measure and record

the distance between the outer surfaces of each pair of opposed rollers to the nearest 0.002 mm.

10.17 Using a point micrometer measure and record to the nearest 0.002 mm the thickness of each TP blade at three locations as in 9.3. Record the identifying mark on each blade with each thickness reading.

10.18 Follow the steps in 10.14 – 10.17 for the second pump.

11. Calculation of Results

11.1 Average the two R-R dimensions from the pre-test measurements and the two R-R dimensions from the post-test measurements. Subtract the post-test measurements from the pre-test measurements to determine the change in R-R dimension during the test. Record the change in R-R dimensions in thousandths of a mm.

11.2 For each TP blade subtract the pre-test width and height measurements from the post-test width and height measurements. Average the three differences for each blade. Average these four average differences to determine the average blade wear. Record the wear in thousandths of a mm.

11.3 Find the maximum pre- and post-test fuel flow rates from the curves of fuel flow rates versus r/min for each pump. Record the difference between the maximum post-test and maximum pre-test fuel flow rate in mm³/stroke for each pump.

11.4 Find the maximum pre- and post-test TP pressure from the curves of TP pressure versus r/min for each pump. Record the difference between the maximum post-test and maximum pre-test TP pressure in kPa for each pump.

11.5 Use the values from 11.1 – 11.4 to calculate the pump lubricity value (PLV) as follows for each pump:

$$PLV = 10.40R + 0.2098F + 31.03B + 0.4693P \quad (1)$$

where:

- PLV* = pump lubricity value, dimensionless,
R = change (post-test–pre-test) in R-R dimension, mm,
F = change (post-test–pre-test) in fuel flow rate, mm³/stroke,

- B* = average (post-test–pre-test) TP blade wear, mm, and
P = change (post-test–pre-test) in TP pressure, kPa.

12. Report

12.1 Report the following information:

12.1.1 Description of the test fuel and the date sample taken.

12.1.2 Dates of testing.

12.1.3 The four SLBOCLE or HFRR results for the fuel.

12.1.4 *R*, *F*, *B*, *P* to four significant figures, and PLV and average PLV to the nearest tenth for each pump.

12.1.5 The average relative humidity over the course of the test.

NOTE 7—Operators are advised to observe and record relative humidity, as it may impact the test results (especially under very dry or very humid conditions).

12.1.6 If the pump seized because of poor fuel lubricity, report the PLV as 10 and the hours at which the seizure occurred.

12.1.7 Any deviations from the prescribed test conditions.

13. Precision and Bias

13.1 *Precision*—Stanadyne has data for 17 fuels with individual PLVs between 0.19 and 9.40. The average PLVs range from 0.45 to 7.63.

13.1.1 The repeatability for these 17 fuels is 2.2. Without the worst pair, the repeatability is 1.4, so this worst pair may be outliers. Without the worst pair the individual values range from 0.19 to 6.10 and the average PLVs range from 0.45 to 6.01.

13.1.2 The reproducibility of this test method will be determined within the next five years.

13.2 *Bias*—The procedure in this test method has no bias because lubricity is not a fundamental and measurable fluid property and thus is evaluated in terms of this test method.

14. Keywords

14.1 boundary lubrication; diesel fuel; friction; lubricity; wear

ASTM International takes no position respecting the validity of any patent rights asserted in connection with any item mentioned in this standard. Users of this standard are expressly advised that determination of the validity of any such patent rights, and the risk of infringement of such rights, are entirely their own responsibility.

This standard is subject to revision at any time by the responsible technical committee and must be reviewed every five years and if not revised, either reapproved or withdrawn. Your comments are invited either for revision of this standard or for additional standards and should be addressed to ASTM International Headquarters. Your comments will receive careful consideration at a meeting of the responsible technical committee, which you may attend. If you feel that your comments have not received a fair hearing you should make your views known to the ASTM Committee on Standards, at the address shown below.

This standard is copyrighted by ASTM International, 100 Barr Harbor Drive, PO Box C700, West Conshohocken, PA 19428-2959, United States. Individual reprints (single or multiple copies) of this standard may be obtained by contacting ASTM at the above address or at 610-832-9585 (phone), 610-832-9555 (fax), or service@astm.org (e-mail); or through the ASTM website (www.astm.org). Permission rights to photocopy the standard may also be secured from the Copyright Clearance Center, 222 Rosewood Drive, Danvers, MA 01923, Tel: (978) 646-2600; http://www.copyright.com/