



Standard Test Method for Evaluation of Aeration Resistance of Engine Oils in Direct-Injected Turbocharged Automotive Diesel Engine¹

This standard is issued under the fixed designation D6894; the number immediately following the designation indicates the year of original adoption or, in the case of revision, the year of last revision. A number in parentheses indicates the year of last reapproval. A superscript epsilon (ϵ) indicates an editorial change since the last revision or reapproval.

INTRODUCTION

Any properly equipped laboratory, without outside assistance, can use the procedure described in this test method. However, the ASTM Test Monitoring Center (TMC)² provides reference oils and an assessment of the test results obtained on those oils by the laboratory. By these means, the laboratory will know whether their use of the test method gives results statistically similar to those obtained by other laboratories. Furthermore, various agencies require that a laboratory utilize the TMC services in seeking qualification of oils against specifications. For example, the U.S. Army imposes such a requirement in connection with several Army engine lubricating oil specifications.

Accordingly, this test method is written for use by laboratories that utilize the TMC services. Laboratories that choose not to use those services may simply ignore those portions of the test method that refer to the TMC.

This test method may be modified by means of information letters issued by the TMC.³ In addition, the TMC may issue supplementary memoranda related to the method. For other information, refer to the research report for this test method.⁴

1. Scope*

1.1 This test method was designed to evaluate an engine oil's resistance to aeration in automotive diesel engine service. It is commonly referred to as the Engine Oil Aeration Test (EOAT). The test is conducted using a specified 7.3 L, direct-injection, turbocharged diesel engine on a dynamometer test stand. This test method was developed as a replacement for Test Method D892 after it was determined that this bench test did not correlate with oil aeration in actual service. The EOAT was first included in API Service Category CG-4 in 1995.

NOTE 1—Companion test methods used to evaluate engine oil performance for specification requirements are discussed in the latest revision of Specification D4485.

¹ This test method is under the jurisdiction of ASTM Committee D02 on Petroleum Products, Liquid Fuels, and Lubricants and is the direct responsibility of Subcommittee D02.B0.02 on Heavy Duty Engine Oils.

Current edition approved May 1, 2013. Published May 2013. Originally approved in 2003. Last previous edition approved in 2011 as D6894 – 11. DOI: 10.1520/D6894-13.

² ASTM Test Monitoring Center (TMC), 6555 Penn Avenue, Pittsburgh, PA 152006-4489.

³ Until the next revision of this test method, the ASTM Test Monitoring Center will update changes in the test method by means of information letters. Information letters may be obtained from the ASTM Test Monitoring Center (TMC), 6555 Penn Avenue, Pittsburgh, PA 152006- 4489. Attention: Administrator. www.astmtmc.cm-u.edu. This edition incorporates revisions contained in all information letters through 12-1.

⁴ Supporting data have been filed at ASTM International Headquarters and may be obtained by requesting Research Report RR:D02-1379.

1.2 The values stated in SI units are to be regarded as standard. No other units of measurement are included in this standard.

1.2.1 *Exception*—Where there is no direct SI equivalent, for example, screw threads, national pipe threads/diameters, and tubing size.

1.3 *This standard does not purport to address all of the safety concerns, if any, associated with its use. It is the responsibility of the user of this standard to establish appropriate safety and health practices and determine the applicability of regulatory limitations prior to use.*

1.4 This test method is arranged as follows:

	Section
Scope	1
Referenced Documents	2
Terminology	3
Summary of Test Method	4
Significance and Use	5
Apparatus	6
Reagents and Materials	7
Preparation of Apparatus	8
Calibration	9
Test Procedure	10
Determination of Test Results	11

*A Summary of Changes section appears at the end of this standard

Report
Precision and Bias
Keywords
Engine System Drawings

12
13
14
Annex A1

2. Referenced Documents

2.1 ASTM Standards:⁵

- D86** Test Method for Distillation of Petroleum Products at Atmospheric Pressure
- D93** Test Methods for Flash Point by Pensky-Martens Closed Cup Tester
- D97** Test Method for Pour Point of Petroleum Products
- D130** Test Method for Corrosiveness to Copper from Petroleum Products by Copper Strip Test
- D287** Test Method for API Gravity of Crude Petroleum and Petroleum Products (Hydrometer Method)
- D445** Test Method for Kinematic Viscosity of Transparent and Opaque Liquids (and Calculation of Dynamic Viscosity)
- D482** Test Method for Ash from Petroleum Products
- D524** Test Method for Ramsbottom Carbon Residue of Petroleum Products
- D613** Test Method for Cetane Number of Diesel Fuel Oil
- D664** Test Method for Acid Number of Petroleum Products by Potentiometric Titration
- D892** Test Method for Foaming Characteristics of Lubricating Oils
- D1250** Guide for Use of the Petroleum Measurement Tables
- D1319** Test Method for Hydrocarbon Types in Liquid Petroleum Products by Fluorescent Indicator Adsorption
- D2500** Test Method for Cloud Point of Petroleum Products
- D2622** Test Method for Sulfur in Petroleum Products by Wavelength Dispersive X-ray Fluorescence Spectrometry
- D2709** Test Method for Water and Sediment in Middle Distillate Fuels by Centrifuge
- D4052** Test Method for Density, Relative Density, and API Gravity of Liquids by Digital Density Meter
- D4175** Terminology Relating to Petroleum, Petroleum Products, and Lubricants
- D4485** Specification for Performance of Active API Service Category Engine Oils
- D4737** Test Method for Calculated Cetane Index by Four Variable Equation
- D5844** Test Method for Evaluation of Automotive Engine Oils for Inhibition of Rusting (Sequence IID) (Withdrawn 2003)⁶
- D5862** Test Method for Evaluation of Engine Oils in Two-Stroke Cycle Turbo-Supercharged 6V92TA Diesel Engine (Withdrawn 2009)⁶
- D6082** Test Method for High Temperature Foaming Characteristics of Lubricating Oils
- D6557** Test Method for Evaluation of Rust Preventive Characteristics of Automotive Engine Oils

- D6594** Test Method for Evaluation of Corrosiveness of Diesel Engine Oil at 135 °C
- E29** Practice for Using Significant Digits in Test Data to Determine Conformance with Specifications
- IEEE/ASTM SI 10 Standard for Use of the International System of Units (SI): The Modern Metric System
- 2.2 SAE Standard:⁷
- J 304** Engine Oil Tests
- 2.3 API Standard:⁸
- API 1509** Engine Oil Licensing and Certification System

3. Terminology

3.1 Definitions:

3.1.1 *automotive, adj*—descriptive of equipment associated with self-propelled machinery, usually vehicles driven by internal combustion engines. **D6594**

3.1.2 *calibrate, v*—to determine the indication or output of a device (e.g., thermometer, manometer, engine) with respect to that of a standard.

3.1.3 *candidate oil, n*—an oil that is intended to have the performance characteristics necessary to satisfy a specification and is to be tested against that specification. **D5844**

3.1.4 *engine oil, n*—a liquid that reduces friction or wear, or both, between the moving parts within an engine; removes heat particularly from the underside of pistons; and serves as combustion gas sealant for the piston rings.

3.1.4.1 *Discussion*—It may contain additives to enhance certain properties. Inhibition of engine rusting, deposit formation, valve train wear, oil oxidation, and foaming are examples. **D5862**

3.1.5 *foam, n—in liquids*, a collection of bubbles formed in or on the surface of a liquid in which the air or gas is the major component on a volumetric basis. **D6082**

3.1.6 *heavy-duty, adj—in internal combustion engine operation*, characterized by average speeds, power output and internal temperatures that are close to the potential maximums. **D4485**

3.1.7 *heavy-duty engine, n—in internal combustion engine types*, one that is designed to allow operation continuously at or close to its peak output.

3.1.8 *lubricant, n*—any material interposed between two surfaces that reduces the friction or wear, or both, between them. **D5862**

3.1.9 *non-reference oil, n*—any oil other than a reference oil; such as a research formulation, commercial oil, or candidate oil. **D5844**

3.1.10 *reference oil, n*—an oil of known performance characteristics, used as a basis for comparison. **D5844**

3.1.11 *test oil, n*—any oil subjected to evaluation in an established procedure. **D6557**

⁵ For referenced ASTM standards, visit the ASTM website, www.astm.org, or contact ASTM Customer Service at service@astm.org. For *Annual Book of ASTM Standards* volume information, refer to the standard's Document Summary page on the ASTM website.

⁶ The last approved version of this historical standard is referenced on www.astm.org.

⁷ Available from Society of Automotive Engineers (SAE), 400 Commonwealth Dr., Warrendale, PA 15096-0001. This standard is not available separately. Either order the SAE Handbook Vol. 3 or the SAE Fuels and Lubricants Standards Manual HS-23.

⁸ Available from American Petroleum Institute (API), 1220 L. St., NW, Washington, DC 20005-4070, <http://www.api.org>.

3.1.12 *used oil, n*—any oil that has been in a piece of equipment (for example, an engine, gearbox, transformer, or turbine), whether operated or not. **D4175**

3.2 Definitions of Terms Specific to This Standard:

3.2.1 *aeration, n*—in liquids, the action of impregnating with air that forms foam bubbles in or on the surface of a liquid or is entrained as a dispersion in that liquid.

3.2.2 *flush, n*—the action of cleaning out the engine oil system using new test oil to remove any residues as well as to minimize possible carryover effect from the previous test oil.

3.2.3 *HEUI, n*—hydraulically-actuated, electronically-controlled, unit injector.⁹

4. Summary of Test Method

4.1 The test engine is a 1994 unit built by International Truck and Engine Corporation¹⁰ (Model No. A215). This engine is equipped with the HEUI fuel system.⁹ It is installed in a fully instrumented test cell.

4.2 The test sequence consists of a five-step, warm-up period followed by a one-step evaluation period for 20 h at maximum power.

4.3 Aerated oil samples are taken after 1 h, 5 h, and 20 h and the percent oil aeration is calculated from the initial volume and the final volume after sitting undisturbed for 30 min.

5. Significance and Use

5.1 *Background*—In the HEUI fuel system, the engine oil from the oil sump not only lubricates the engine, it also supplies a high-pressure oil system that takes oil from the main gallery and pressurizes it up to 20.7 MPa in a plunger pump (see Fig. A1.1). This oil is used to operate unit injectors that, when used in combination with intensifiers, increase the fuel injection pressure up to 145 MPa, independent of engine speed. The electronic controls permit varied injection timing and duration to provide optimum fuel economy and emissions. This system may, however, circulate all the oil in the sump in approximately 8 s; as a consequence, aeration of the oil can occur with some engine oils. International determined that 8 % oil aeration was the limit beyond which engine operation and performance would be impaired in actual service.

5.1.1 Prior to 1994, the ability of an engine lubricant to resist aeration was measured by Test Method **D892**. During the development of the API CG-4 category in 1994, however, it was found¹¹ that this bench test did not correlate with aeration in the International T 444E engine. The EOAT was developed, therefore, to provide a better measurement of the ability of a lubricant to resist aeration during engine operation. This test has been included in API CG-4, CH-4, and CI-4 categories for heavy-duty diesel engine oils.

⁹ Glassey, S. F., Stockner, A. R., and Flinn, M. A., “HEUI—A New Direction for Diesel Engine Fuel System,” *SAE Publication 930270*; Hower, M. J., Mueller, R. A., Oehlerking, D. A., and Zielke, M. R., “The New Navistar T444E Direct-Injection Turbocharged Diesel Engine,” *SAE Publication 930269*.

¹⁰ Hereinafter referred to as International, which is the trademark of the International Truck and Engine Corporation.

¹¹ McGeehan et al., “The World’s First Diesel Engine Oil Category for Use with Low-Sulfur Fuel: API CG-4,” *SAE Publication 981371*.

5.2 *Method*—The data obtained from the use of this test method provide a comparative index of the aeration resistance of engine oils used in medium- and heavy-duty truck diesel engines.

5.3 *Use*—The tendency of engine oils to aerate in direct-injection, turbocharged diesel engines is influenced by a variety of factors, including engine oil formulation variables, oil temperature, sump design and capacity, residence time of the oil in the sump, and the design of the pressurized oil systems. In some engine-oil-activated injection systems, the residence time of the oil in the sump is insufficient to allow dissipation of aeration from the oil. As a consequence, aerated oil can be circulated to the injector intensifiers, adversely affecting the injection timing characteristics and engine operation.

6. Apparatus

6.1 *Test Engine*—The test engine^{12,13} is an International 1994, 7.3 L, direct-injection, turbocharged, V-8, diesel engine, rated at 160 kW at 3000 rpm. The engine model number is A215. The engine arrangement is shown in Figs. A1.2 and A1.3 and the lubrication system in Fig. A1.4. This engine is equipped with the HEUI fuel system (see 5.1 and Fig. A1.1). Details of the engine are documented in the International T 444E Diesel Engine Service Manual for Truck Application Form EGES-121 dated April 2002.¹⁴ The engine serial number carries the designation 7.4JU2UXXXXXX. The test engine is installed in a fully instrumented test cell.

6.1.1 *Engine Modification*—Install a ¼ in. male national pipe thread (NPT) stainless steel hex nipple^{15,13} in the threaded outlet on the right (passenger) side of the engine’s high-pressure oil reservoir. Install a ¼ in. female NPT inlet and outlet, stainless steel, ball-valve onto the hex nipple with the flow arrow facing away from the reservoir. Install a ¼ in. male NPT to male No. 4 SAE (JIC) 37° flare stainless steel adapter fitting in the downstream side of the ball valve. Make up a polytetrafluoroethylene (PTFE)-lined, stainless steel braid, No. 4 hose, with female swivel No. 4 SAE (JIC) 37° female flare fittings on each end. The overall line length should be approximately 115 cm. Modify a male No. 4 SAE (JIC) 37° flare to ¼ in. fractional tube female compression adapter fitting so that there is a 0.394 mm orifice through the fitting. Insert a 37.5 cm long, ¼ in. thin-wall, steel, fractional tube (this is to be the sample wand) into the female compression adapter and tighten. For safety, install an insulating handle around the steel tube to avoid being burned while holding the wand.

6.2 *Power Absorption*—Install a 186 kW eddy-current absorption dynamometer in the test cell.

¹² The sole source of supply of the engine known to the committee at this time is Franklin Power Products, 400 North Forsythe St., Franklin, IN 46131.

¹³ If you are aware of alternative suppliers, please provide this information to ASTM International Headquarters. Your comments will receive careful consideration at a meeting of the responsible technical committee,¹ which you may attend.

¹⁴ Available through any authorized International dealer.

¹⁵ The hardware specified in this section may be sourced from the following suppliers: Nupro Company, 4800 East 345th St., Willoughby, OH 44094; Parker Hannifin Corporation, 1300 North Freedom St., Ravenna, OH 44266; Swagelok Company, Solon, OH 44139.

TABLE 1 Oil Circulation Rates in the International 7.3 L Engine

Engine speed, rpm	Oil capacity, L	Oil flow rate, L/min	Time for one pass through, s	Circulation of oil in sump, times/min
3000	13.3	105	7.6	8

6.3 *Aeration*—The HEUI system takes oil from the main gallery and pressurizes it in a plunger pump up to 20.7 MPa. The arrangement is shown in Fig. A1.1. The pressurized oil operates unit injectors that increase the fuel pressure up to 145 MPa with the help of intensifiers (see Fig. A1.5). The electronic controls permit varied injection timing and duration to provide optimum fuel economy and emissions. As shown in Table 1, this operation can circulate all the lubricating oil in the sump in approximately 8 s. For oils with unsatisfactory aeration resistance, this very short residence time is insufficient to allow aeration in the oil to dissipate. As a consequence, aerated oil is circulated to the injector intensifiers, adversely affecting the injection timing characteristics and engine operation.

6.4 *Instrumentation*—Instrument the engine and dynamometer to measure the following parameters:

- Engine speed, rpm
- Torque, N·m
- Power, kW
- Fuel flow rate, kg/h
- Coolant temperature, in and out, °C
- Oil gallery temperature, °C
- Intake air temperature, °C
- Fuel temperature, °C
- Intake manifold temperature after turbocharger, °C
- Ambient temperature, °C
- Oil gallery pressure, kPa
- Intake manifold pressure, kPa
- Exhaust pressure, after turbocharger, at left and right manifolds, kPa
- Crankcase pressure, kPa
- Intake air pressure after filter, kPa
- Tailpipe pressure, kPa

6.5 Miscellaneous:

6.5.1 Nine 100 mL graduated glass cylinders.

6.5.2 A weighed, glass sample bottle, of suitable capacity to hold 120 mL, with inert, lined lids.

6.5.3 A weighed oil-drain container, of suitable capacity, for collecting hot purged oil; a 20 L bucket is convenient.

7. Reagents and Materials

7.1 *Engine Oil*—Use only engine oils of performance category API CI-4, CH-4, and CG-4 or their equivalent performance replacements when running the engine for passivating sealants (see 8.3.3), breaking-in and other routine operations.

7.2 *Reference Oils*—The TMC uses reference oils (TMC 1004 and TMC 1005) to establish test precision. Calibration tests using these two reference oils are required after 30 operationally valid non-reference oil test runs or one year, whichever is sooner. As new data are generated at the laboratories running this test, the TMC updates the test precision accordingly.

7.3 *Test Fuel*—Use fuel designated as either PC-9 or PC-9-HS containing 0.03 % mass to 0.05 % mass sulfur for this

TABLE 2 Test Fuel Specifications

Measurement	Specification	Test Method
Total sulfur, mass %	0.03 to 0.05	D2622
Gravity, API	32 to 36	D287 or D4052
Hydrocarbon Composition		
Aromatics, volume %	28 to 35	D1319
Olefins, volume %	Report	D1319
Saturates, volume %	Report	D1319
Cetane Index	Report	D4737
Cetane Number	42 to 48	D613
Copper Strip Corrosion, rating after 3 h at 100°C	3 max	D130
Total Acid Number, mg KOH/g	Report	D664
Strong Acid Number, mg KOH/g	Report	D664
Flash Point, °C	Report	D93
Cloud Point, °C	−12 max	D2500
Pour Point, °C	−18 max	D97
Ash, weight %	0.01 max	D482
Carbon residue on 10 % residuum, %	0.3 max	D524 (10 % bottoms)
Water and Sediment, % volume	0.05 max	D2709
Kinematic viscosity at 40°C, mm ² /s	2.0 to 3.2	D445
Distillation, °C		
IBP	177 to 199	D86
10 %	210 to 232	D86
50 %	249 to 277	D86
90 %	299 to 327	D86
EP	327 to 360	D86

test.^{16,13} All fuel shall meet the fuel specifications shown in Table 2. Include in the final report the fuel analysis, provided by the fuel supplier, for the last batch of fuel used for the test. If more than one batch is used during the test, note this in the comments section with the appropriate percentages of run time.

7.4 *Engine Coolant*—The engine coolant shall be 50/50 percent (by volume) commercially additized ethylene glycol coolant/water. To protect the cylinder walls from external cavitation, add commercially available supplementary coolant additives (SCAs), initially and after every 200 h of engine operation, at the SCA manufacturer's recommended treat rate. Water shall be deionized, demineralized, or distilled.

7.5 Cleaning Materials:

7.5.1 *Solvent*—Use aliphatic naphtha (Stoddard) hydrocarbon solvent. (**Warning**—Flammable. Eye irritant. Wear goggles or face shield (as for gasoline).)

7.5.2 *Engine Cooling System Cleanser*—Use the following:
7.5.2.1 Oxalic Acid Dihydrate Technical Grade. (**Warning**—Toxic Substance. Avoid contact with eyes, skin, and clothing.)

7.5.2.2 Petro Dispersant 425 surfactant (the sodium salt of alkylatid naphthalene).

NOTE 2—These chemicals can be purchased as a premixed pack.^{17,13}

¹⁶ The sole source of supply of the apparatus known to the committee at this time is Haltermann Products, 1201 South Sheldon Road, PO Box 429, Channel View, TX 77530-0426.

¹⁷ The sole source of supply of the premixed cooling system cleanser known to the committee at this time is Wrico Corporation, 4835 Whirlwind, San Antonio, TX 78217.

TABLE 3 Engine Test Sequence

NOTE 1—The test sequence consists of a five-step, warm-up condition followed by a one-step, on-test condition.

a) Five-step, Warm-up Condition					
Step	rpm	Torque, N-m	Ramp Time Torque, s	Ramp Time rpm, s	Step Time, min
1	1200	120	0	0	4
2	2000	215	120	90	3
3	3000	240	120	120	3
4	3000	300	120	0	3
5	3000	365	300	0	7

b) One-step, On-test Condition		
Step	rpm	Power max
1	3000	

8. Preparation of Apparatus

8.1 This section assumes that the engine test stand facilities and hardware as described in Section 6 are in place. Emphasis is on the recurring preparations needed in the routine conduct of the test.

8.2 Test Stand Preparation:

8.2.1 *Instrument Preparation*—Calibrate, and record for future reference, the temperature measuring system in a manner consistent with good laboratory practices.

8.2.2 *Hose Replacement*—Inspect all hoses and replace any that have deteriorated. Check for internal wall separations that would cause flow restriction.

8.3 Engine Preparation:

8.3.1 *General Assembly Instructions*—Assemble the external engine accessory components according to the detailed description in the International T 444E Diesel Engine Service Manual. In cases of disparity, however, the explicit instructions contained in this test method take precedence over the service manual.

8.3.1.1 Do not use sealers in tape form.

NOTE 3—Loose shreds of tape can circulate in the engine oil and plug critical orifices.

8.3.2 *Bolt Torque Specifications*—When installing the engine components, use a calibrated torque wrench to obtain the values specified in the International Engine Service Manual.

NOTE 4—Over-torquing can damage threads, thereby preventing attainment of the correct torque, and may require replacement of the damaged part.

NOTE 5—The specified torque values apply only to clean and lightly-lubricated threads. Dirty or dry threads produce friction that prevents accurate measurement of the torque.

8.3.3 *Sealing Compounds*—Use only International approved room temperature vulcanized (RTV) silicone rubber (T442) sealers.^{18,13} Passivate new sealants by running the engine under one-step, on-test conditions (see Table 3b) for 20 h, using an engine as detailed in 7.1.

¹⁸ The sole source of supply of the apparatus known to the committee at this time is Wacker Silicone Corporation, 3301 Sutton Road, Adrian, MI 48221-9397.

NOTE 6—Silicone from new silicone-based seals may contaminate the used oil thereby contributing to aeration. Passivation removes this silicone.

8.3.4 *Thermostat*—Modify the thermostat on the test engine so that it remains open.

8.3.5 *Alternator*—If an alternator is installed on the engine, do not energize the fields to maintain battery charge because the resulting absorption of power from the engine can adversely affect the test result.

9. Calibration

9.1 Test Stand/Engine Calibration:

9.1.1 Procure a supply of reference oils, as needed (see 9.1.2), from the TMC.

9.1.1.1 These oils have been formulated or selected to represent specific chemistry types, or performance levels, or both. Each reference oil is identified by a unique identifying code on the container label.

9.1.2 Test the Reference Oils:

9.1.2.1 Reference oil tests on each test stand/engine shall be conducted according to ASTM TMC Lubricant Test Monitoring System (LTMS) guidelines. Calibration tests using the reference oils are required after 30 operationally valid, non-reference oil test runs or one year, whichever is sooner. If TMC-acceptable results are obtained on the reference oils, the test stand/engine is considered calibrated.

9.1.2.2 The effective date of a reference oil test is the LTMS date and time of the reference test. Test start time is defined as the introduction of the reference oil into the engine. The LTMS date and time are defined as the date and time the test was completed unless a different date and time are assigned by the TMC.

9.1.3 Immediately after completion of the test analysis, report the reference oil test results to the TMC according to the following guidelines:

9.1.3.1 Use the appropriate data reporting forms (see 12.1 and Note 13) and complete all the required blank fields.

9.1.3.2 Transmit the reference oil test data by electronic means or by facsimile, including all the reporting forms in the transmission.

NOTE 7—Specific protocols for the electronic transmission of test data are available from the TMC.

9.1.4 The TMC will review the transmitted reference oil test results and use the LTMS to determine test acceptability.

9.1.5 *Reference Oils Identification*—Do not subject reference oils to either physical or chemical analyses for identification purposes. Identifying the oils by analyses could undermine the confidentiality required to operate an effective blind reference system. Therefore reference oils are supplied with the explicit understanding that they will not be subjected to analyses other than those specified within this procedure unless specifically authorized by the TMC. In such instances, supply written confirmation of the circumstances involved, the data to be obtained, and the name of the person requesting the analysis to the TMC.

NOTE 8—Policies for the use and analysis of ASTM reference oils are available from the TMC.

TABLE 4 Engine Conditions during Test Operation

a) Critical Parameters to be Recorded Hourly	
Parameter	Control Range
Engine speed, rpm	3000 ± 10
Coolant out temperature, °C	100.5 ± 1.5
Coolant in temperature, °C	88 ± 3
Maximum oil temperature, °C	121
Intake air temperature, °C	29 ± 3
Fuel temperature, °C	66 ± 6
Maximum intake manifold temperature, °C	163
Intake air pressure after filter, kPa	3.75 ± 1.25
b) Non-critical Parameters to be Recorded Hourly	
Parameter	
Torque, N.m	
Power, kW	
Fuel flow rate, kg/h	
Ambient temperature, °C	
Oil gallery pressure, kPa	
Intake manifold pressure, kPa	
Tailpipe pressure, kPa	
Exhaust manifold pressure (left), kPa	
Exhaust manifold pressure (right), kPa	
Crankcase pressure, kPa	

9.2 *Instrument Calibration*—Record all instrument calibrations for further reference. For a new engine, perform a complete test stand instrument calibration prior to conducting the initial reference test. For a previously calibrated (existing) stand/engine, calibrate the following systems prior to the next reference test: (1) engine load measurement; (2) fuel flow, and (3) engine speed measurement. As a minimum, calibrate all other instruments after 30 non-reference oil tests or every year, whichever is sooner.

9.2.1 *Thermocouples and Temperature Measurement System*—Use Type E thermocouples as the minimum quality temperature measuring system. Prior to running a new engine reference, or as needed, check the calibration of the test stand temperature measurement system (thermocouple through to the readout) at the test stand using the existing readout system. For those temperatures controlled during test operation (see Table 4a), individual temperature sensors shall indicate within ±0.56 °C of the laboratory calibration standards.

10. Test Procedure

10.1 Pre-test Engine Preparation:

10.1.1 Turn on all water valves in the cell (tower and chiller).

10.1.2 Fuel the test engine with LSRD-4 diesel fuel meeting the specifications given in Table 2.

10.1.3 Install a new oil filter.¹⁹

10.1.4 First Engine Flush Procedure:

10.1.4.1 Charge the engine with 11.6 kg of test oil. To ensure the oil galleries, filter and high-pressure reservoir are filled prior to starting the engine, pressure charge the engine using an external reservoir and pump.

10.1.4.2 Verify the sump oil level with the dip stick and record the mass of oil used.

NOTE 9—As part of good laboratory practice, approximately 120 mL of the installed test oil may be collected at this stage for possible future

laboratory analysis. Such analysis may be useful in any investigation carried out to find the cause of an engine malfunction or failure.

10.1.4.3 Start the engine and verify that the cooling system pressure is 60 kPa ± 6 kPa. If necessary, pressurize the system to this value.

10.1.4.4 Run the engine through the five-step, warm-up conditions specified in Table 3a.

10.1.4.5 Without stopping the engine, run for 1 h at the one-step, on-test condition specified in Table 3b. Target the critical control parameters to the mean values shown in Table 4a.

10.1.4.6 At the end of the one-step condition, stop the engine and drain the test oil for 30 min.

10.1.5 *Second Engine Flush Procedure*—Flush the engine a second time by repeating steps 10.1.3 and 10.1.4.1 through 10.1.4.6.

10.2 Test Operation:

10.2.1 To ensure removal of the maximum amount of flush oil, vacuum out the high-pressure reservoir while the oil is draining from the second oil flush.

10.2.2 Weigh and install a new oil filter.¹⁹

10.2.3 Repeat step 10.1.4.1.

10.2.4 Verify the sump oil level with the dip stick and record the mass of oil used. In the weighed sample bottle, collect approximately 120 mL of the installed test oil.

NOTE 10—This sample is for subsequent chemical analysis, if this is desired, for example, to provide evidence regarding the actual oil used in the test or to investigate the cause of an engine malfunction or failure.

10.2.5 Repeat steps 10.1.4.3 and 10.1.4.4.

10.2.6 Without stopping the engine, run for 20 h at the one-step, on-test conditions specified in Table 3b. Target the critical control parameters at the mean values shown in Table 4a. Record hourly and report the values of all the parameters listed in Table 4. If any of the critical control parameters fall outside the range specified in Table 4a, the test is invalid.

10.2.7 Start time for the test is when the on-test condition step is initiated. No top-up oil is allowed. The engine may be stopped at any time during the first 19 h. However, if the engine is shut down in the last hour, the test shall be deemed invalid.

10.2.8 First Set of Measurements:

10.2.8.1 Clean three 100 mL graduated glass cylinders with aliphatic naphtha solvent and place next to the engine to warm-up.

10.2.8.2 After 1 h (±2 min) from the start of the test, with the engine running, open the valve (see 6.1.1) on the high-pressure reservoir, insert the wand into the clean, weighed, oil-drain container and purge the sample line and wand for 12 s to 13 s.

10.2.8.3 Insert the wand to the bottom of one of the pre-warmed graduated cylinders. As the oil flows out, raise the wand so that its end remains approximately 5 mm below the surface of the oil.

NOTE 11—If the end of the wand is held above the oil surface, air entrainment can occur; if held too far below, its displacement volume can result in an incorrect sample volume being collected.

10.2.8.4 Collect a sample of approximately 90 mL.

¹⁹ Motorcraft part # FL-1995; available commercially.

10.2.8.5 Repeat 10.2.8.3 to 10.2.8.4 twice.

10.2.8.6 Shut off the valve on the high-pressure reservoir.

10.2.8.7 Place the three graduated cylinders in a holder and immediately record both the meniscus level and the oil temperature.

10.2.8.8 After 30 min, read and record the meniscus levels and temperatures in the three cylinders. Dispose of the samples in the weighed oil-drain container. (Do not put the oil samples back in the engine.)

10.2.9 *Second Set of Measurements:*

10.2.9.1 Repeat 10.2.8.1.

10.2.9.2 After 5 h (± 2 min) from the start of the test, with the engine running, open the valve (see 6.1.1) on the high-pressure reservoir, insert the wand into the weighed, oil-drain container and purge the sample line for 12 s to 13 s.

10.2.9.3 Repeat steps 10.2.8.3 through 10.2.8.8.

10.2.10 *Third Set of Measurements:*

10.2.10.1 Repeat 10.2.8.1.

10.2.10.2 After 20 h (± 2 min) from the start of test, with the engine still running, open the valve (see 6.1.1) on the high-pressure reservoir, insert the wand into the weighed, oil-drain container and purge the sample line for 12 to 13 s.

10.2.10.3 Repeat steps 10.2.8.3 through 10.2.8.8.

10.3 *Post-test Activities:*

10.3.1 At the end of the 20 h one-step condition, stop the engine and drain the test oil from the engine for 30 min.

10.3.2 Vacuum out the high-pressure reservoir, discharging the oil into the oil-drain container.

10.3.3 Weigh the end of test (EOT) drain oil, the oil filter, the sample bottle and the oil-drain container.

10.3.4 From the before and after masses of the oil filter, sample bottle and oil-drain bucket and the mass of the EOT drain oil, calculate and record the total mass of oil.

NOTE 12—These data allow the oil consumption of the engine to be measured and engine integrity to be monitored.

11. Determination of Test Results

11.1 Use Table 6 of ASTM-IP Petroleum Measurement Tables (Guide D1250) to correct oil volumes measured in 10.2.8, 10.2.9, and 10.2.10 to 15.6 °C and record the data. Calculate the percentage oil aeration for each of the three samples collected at 1 h, 5 h, and 20 h as follows:

$$\% \text{ oil aeration} = \frac{(\text{initial volume} - \text{final volume}) \times 100}{\text{initial volume}} \quad (1)$$

where:

all volumes are corrected to 15.6 °C;

the initial volume is the volume of the sample as soon as it is collected; and

the final volume is the volume measured 30 min after it is collected.

Calculate the mean value of the three results for the samples collected at 1 h, 5 h, and 20 h.

12. Report

12.1 Reference oil tests require the use of the standardized report form set and data dictionary for reporting test results and for summarizing the operational data.

TABLE 5 EOAT Reference Oil Precision Statistics^{A,B}

Parameter	Intermediate Precision, i.p.	i.p. standard deviation, S _{i.p.}
Average Engine Oil Aeration, %	0.67	0.25

^A These statistics are based on ASTM TMC Reference Oils 1004 and 1005 and were applicable on June 24, 2002.

^B Reproducibility data are unavailable at the present time.

NOTE 13—The actual report forms and data dictionary can be downloaded separately from the ASTM TMC Web Pages at <http://astmtmc.cmu.edu/> or can be obtained in hardcopy format from the TMC.

12.2 Report the mean and individual values for the samples collected at 1 h, 5 h, and 20 h.

12.3 *Report Format:*

12.3.1 *Precision of Reported Units*—Use Practice E29 for rounding-off data. Use the rounding-off method to report data to the required precision.

13. Precision and Bias

13.1 *Precision:*

13.1.1 Test precision is established on the basis of operationally valid reference oil test results monitored by the TMC. Research Report RR:D02-1379⁴ contains industry data developed prior to establishment of this test method.

13.1.2 *Intermediate Precision (formerly called repeatability) Conditions*—Conditions where test results are obtained with the same test method using the same test oil, with changing conditions such as operators, measuring equipment, test stands, test engines, and time.

NOTE 14—Intermediate Precision is the appropriate term for this test method, rather than repeatability, which defines more rigorous within laboratory conditions.

13.1.2.1 *Intermediate Precision Limit (i.p.)*—The difference between two results obtained under intermediate precision conditions that in the long run, in the normal and correct conduct of the test method, exceed the value shown in Table 5 in only one case in twenty.

13.1.3 *Reproducibility Conditions*—Conditions where test results are obtained with the same test method using the same test oil in different laboratories with different operators using different equipment.

13.1.3.1 *Reproducibility Limit (R)*—The difference between two results obtained under reproducibility conditions that would, in the long run, in the normal and correct conduct of the test method, exceed the values in Table 5 in only one case in twenty.

13.1.4 The TMC will update the precision data as it becomes available.

13.2 *Bias*—Bias is determined by applying an accepted statistical technique to reference oil test results and, when a significant bias is determined, a severity adjustment is permitted for non-reference oil test results (refer to the TMC for details).

14. Keywords

14.1 aeration; automotive; diesel engine; EOAT; foaming; heavy-duty; HEUI; medium-duty

ANNEX

(Mandatory Information)

A1. ENGINE SYSTEM DRAWINGS

A1.1 Engine system drawings are provided in Figs. A1.1-
A1.5.

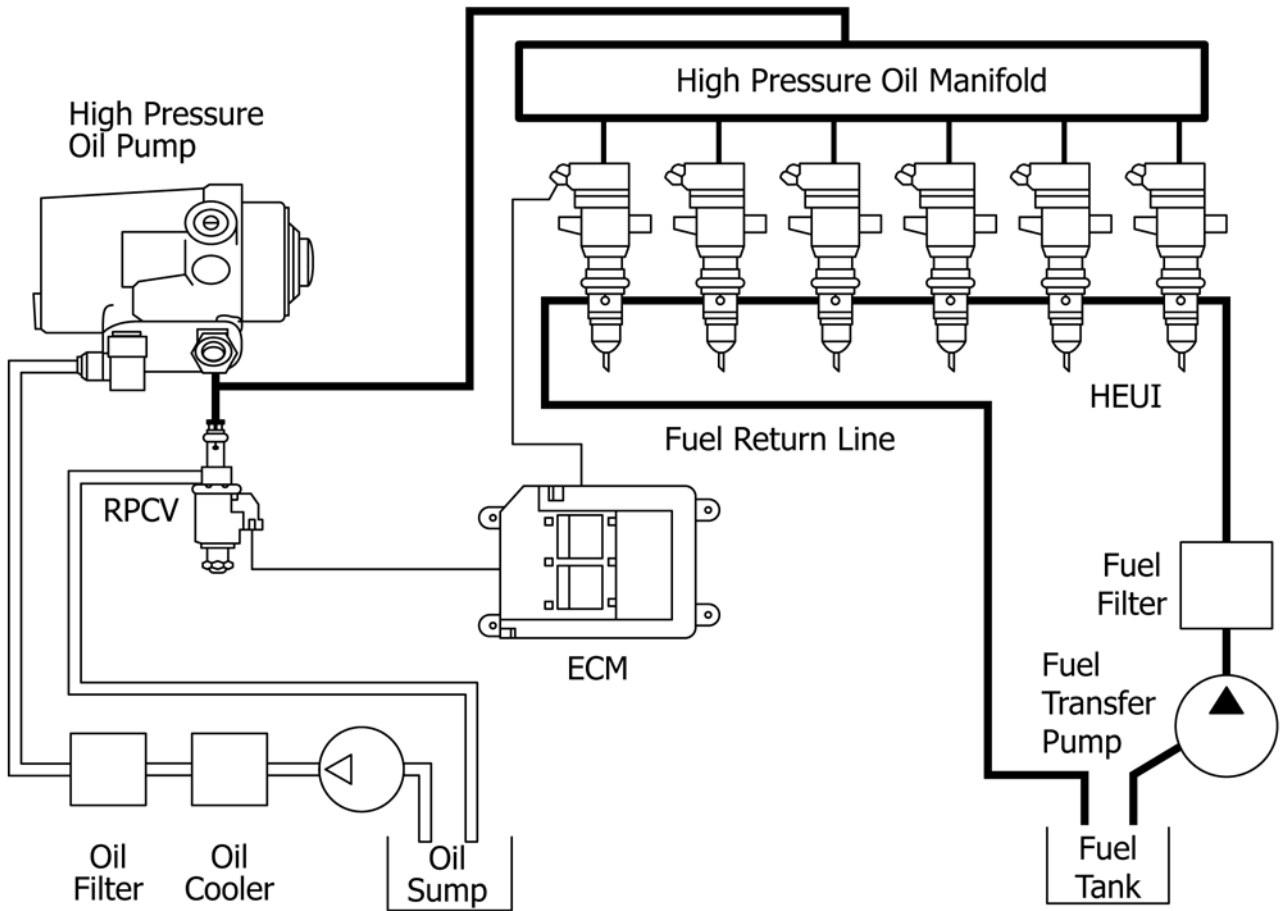
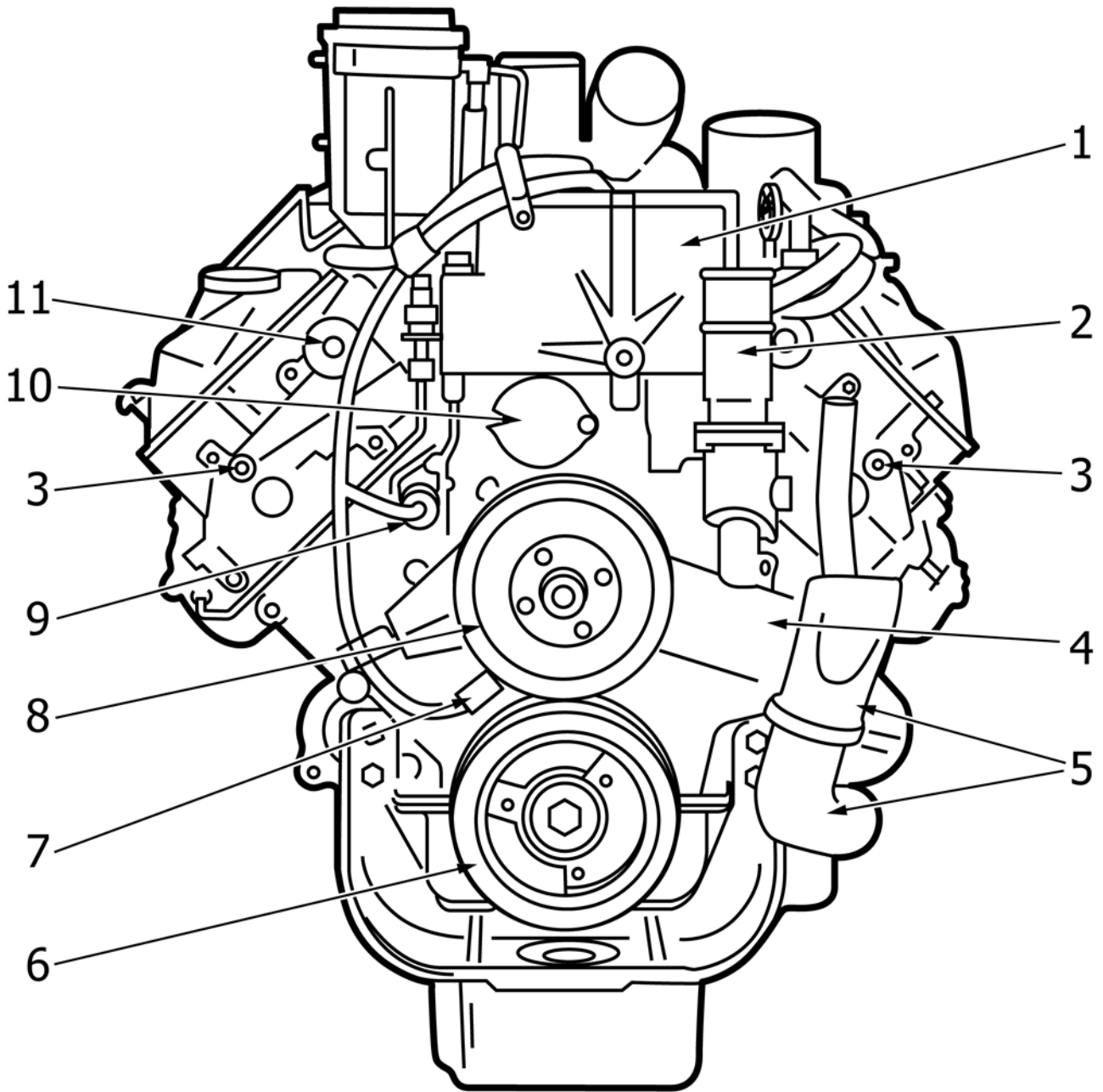

FIG. A1.1 HEUI System Components



- 1. Lube Oil Reservoir
- 2. Water Outlet Tube
- 3. Fuel Gallery Plug (2 per head)
- 4. Water Pump
- 5. Water Inlet Tube
- 6. Crankshaft Vibration Damper Pulley

- 7. Camshaft Position Sensor
- 8. Water Pump Pulley
- 9. Coolant Temperature Sensor
- 10. High Pressure Pump Gear Access Cover
- 11. High Pressure Oil Supply Rail End Plug (4)

FIG. A1.2 Front View of International-Built, 7.3 L Engine

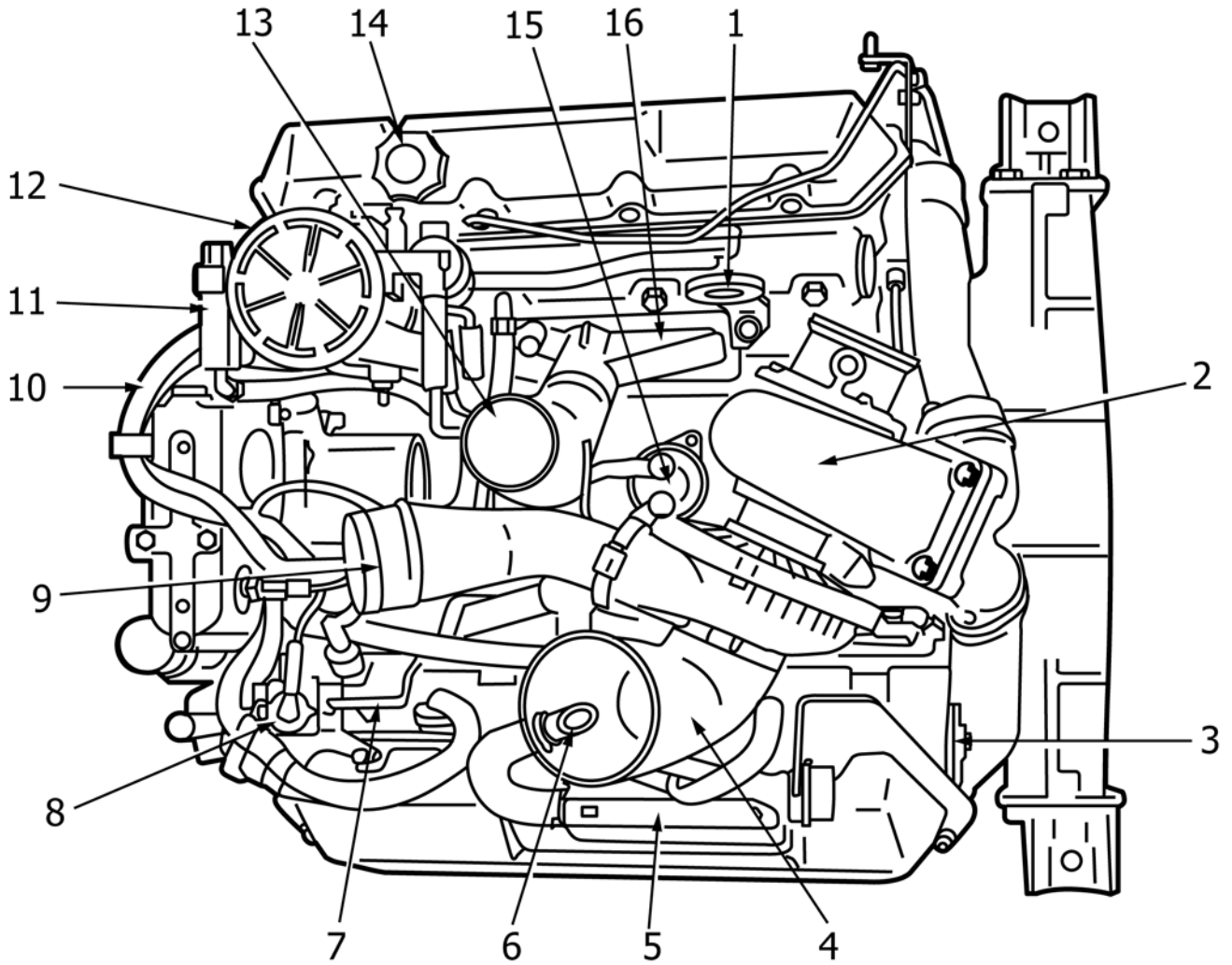

- 1. Engine Lifting Eye, Right Bank
- 2. Turbocharger
- 3. Engine Lifting Eye, Rear Left Bank
- 4. Turbocharger Air Inlet Elbow
- 5. Crankcase Breather
- 6. Turbocharger Air Inlet Elbow Pitot
- 7. Engine Lifting Eye, Front Left Bank
- 8. Glow Plug Relay

- 9. Charge Air Cooling Tube Turbo Air Outlet
- 10. Engine Electrical Harness
- 11. Fuel Pressure Regulating Valve
- 12. Fuel Filter
- 13. Charge Air Cooling Tube Cyl-Head Air Inlet
- 14. Oil Filler Cap
- 15. Fuel Supply Pump
- 16. Air Intake Cover (2)

FIG. A1.3 Top View of International-Built, 7.3 L Engine

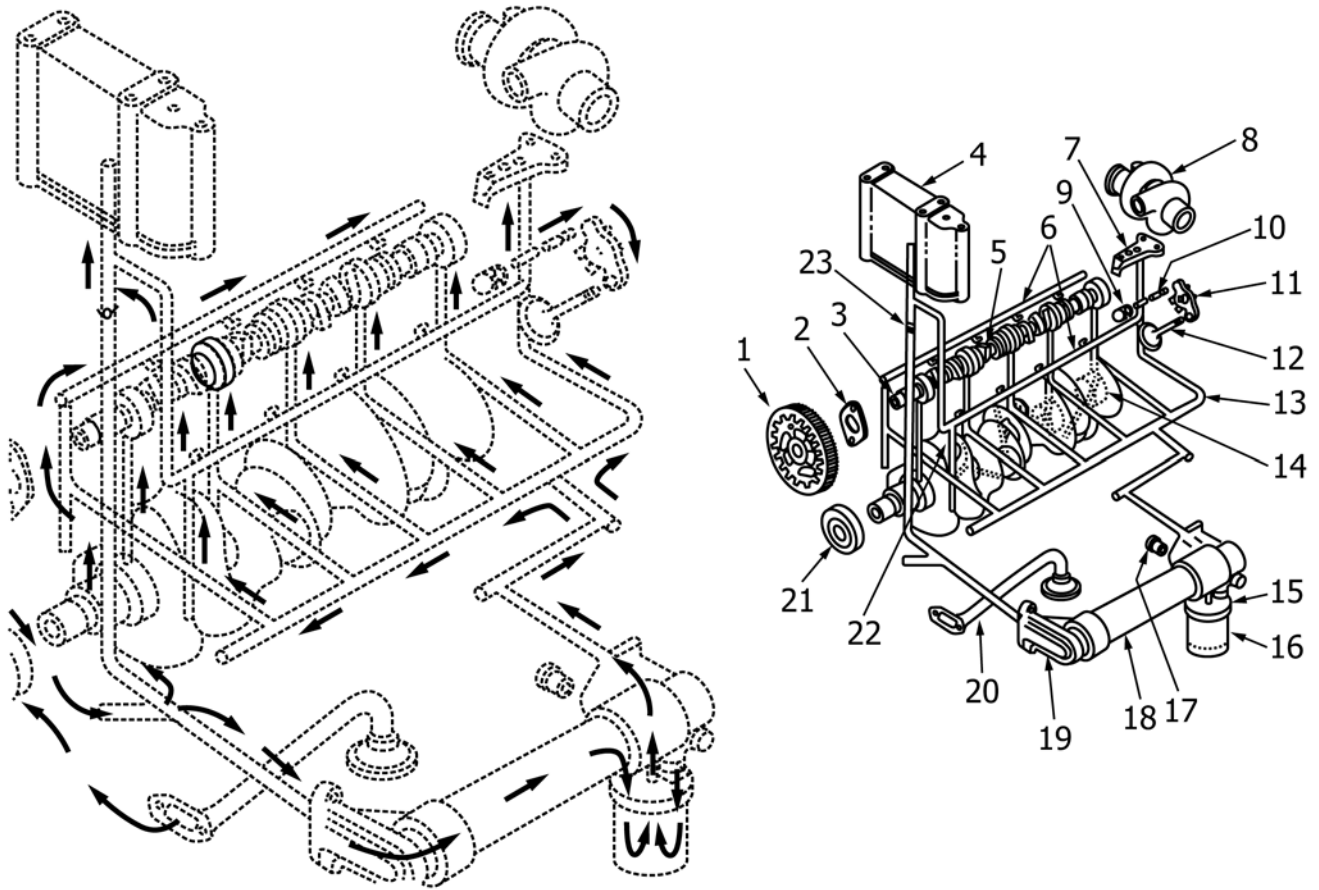

1. Camshaft Gear
2. Camshaft Thrust Plate
3. Camshaft
4. High Pressure Lube Oil Reservoir
5. Piston Cooling Jets (8)
6. Hydraulic Valve Lifter Oil Gallery
7. Turbocharger Pedestal
8. Turbocharger Assembly
9. Hydraulic Valve Lifter
10. Push Rod
11. Valve Lever Assembly
12. Intake/Exhaust Valve

13. Main Oil Gallery
14. Main Crankshaft Bearings
15. Oil Filter Bypass Valve
16. Oil Filter
17. Oil Pressure Regulating Valve
18. Oil Cooler
19. Oil Cooler Header
20. Oil Pick-up Tube
21. Oil Pump
22. Connecting Rod Bearings
23. Check Valve

FIG. A1.4 Lubrication System

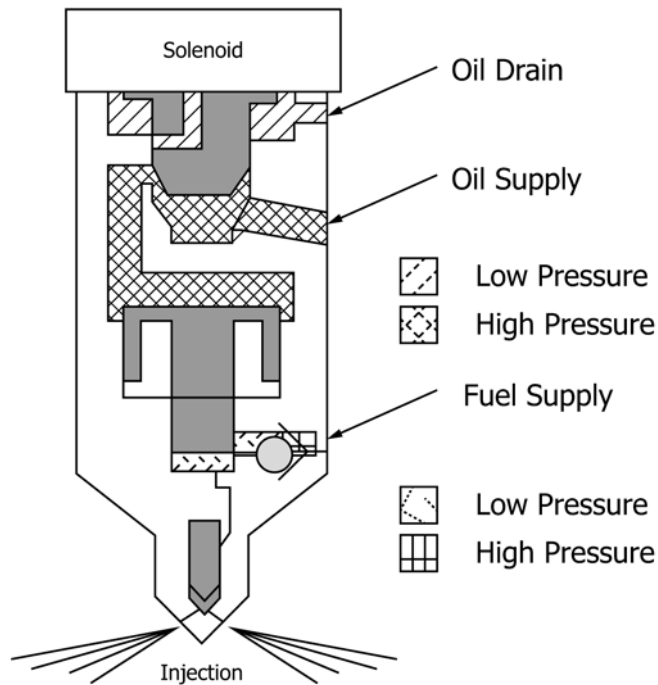

FIG. A1.5 Oil Circulation in the HEUI Fuel Injector System of the International-Built 7.3 L Engine

SUMMARY OF CHANGES

Subcommittee D02.B0.02 has identified the location of selected changes to this standard since the last issue (D6894 – 11) that may impact the use of this standard.

- (1) Subsection 7.3 has a revised fuel designation.
- (2) Editorial changes were made, applying Form and Style (including SI 10) guidelines.

ASTM International takes no position respecting the validity of any patent rights asserted in connection with any item mentioned in this standard. Users of this standard are expressly advised that determination of the validity of any such patent rights, and the risk of infringement of such rights, are entirely their own responsibility.

This standard is subject to revision at any time by the responsible technical committee and must be reviewed every five years and if not revised, either reapproved or withdrawn. Your comments are invited either for revision of this standard or for additional standards and should be addressed to ASTM International Headquarters. Your comments will receive careful consideration at a meeting of the responsible technical committee, which you may attend. If you feel that your comments have not received a fair hearing you should make your views known to the ASTM Committee on Standards, at the address shown below.

This standard is copyrighted by ASTM International, 100 Barr Harbor Drive, PO Box C700, West Conshohocken, PA 19428-2959, United States. Individual reprints (single or multiple copies) of this standard may be obtained by contacting ASTM at the above address or at 610-832-9585 (phone), 610-832-9555 (fax), or service@astm.org (e-mail); or through the ASTM website (www.astm.org). Permission rights to photocopy the standard may also be secured from the Copyright Clearance Center, 222 Rosewood Drive, Danvers, MA 01923, Tel: (978) 646-2600; http://www.copyright.com/