



Designation: D6890 – 16^ε¹

Standard Test Method for Determination of Ignition Delay and Derived Cetane Number (DCN) of Diesel Fuel Oils by Combustion in a Constant Volume Chamber^{1,2}

This standard is issued under the fixed designation D6890; the number immediately following the designation indicates the year of original adoption or, in the case of revision, the year of last revision. A number in parentheses indicates the year of last reapproval. A superscript epsilon (ϵ) indicates an editorial change since the last revision or reapproval.

^ε¹ NOTE—Subsection 11.3.2.1 was corrected editorially in March 2017.

1. Scope*

1.1 This automated laboratory test method covers the quantitative determination of the ignition characteristics of conventional diesel fuel oil, oil-sands based fuels, hydrocarbon oils, blends of fuel containing biodiesel material, diesel fuel oils containing cetane number improver additives, and is applicable to products typical of ASTM Specification D975 grades No. 1-D S15, No. 1-D S500, and No. 1-D S5000, and grades No. 2-D S15, No. 2-D S500, and No. 2-D S5000 diesel fuel oils, European standard EN 590, and Canadian standards CAN/CGSB-3.517 and 3.520. The test method may also be applied to the quantitative determination of the ignition characteristics of diesel fuel blending components.

1.2 This test method measures the ignition delay of a diesel fuel injected directly into a constant volume combustion chamber containing heated, compressed air. An equation correlates an ignition delay determination to cetane number by Test Method D613, resulting in a derived cetane number (DCN).

1.3 This test method covers the ignition delay range from 3.1 ms to 6.5 ms (64 DCN to 33 DCN). The combustion analyzer can measure shorter and longer ignition delays, but precision may be affected. For these shorter or longer ignition delays the correlation equation for DCN is given in Appendix X2. There is no information about how DCNs outside the 33 to 64 range compare to Test Method D613 cetane numbers.

1.4 For purposes of determining conformance with the parameters of this test method, an observed value or a calculated value shall be rounded “to the nearest unit” in the

¹ This test method is under the jurisdiction of ASTM Committee D02 on Petroleum Products, Liquid Fuels, and Lubricants and is the direct responsibility of Subcommittee D02.01 on Combustion Characteristics.

Current edition approved April 1, 2016. Published April 2016. Originally approved in 2003. Last previous edition approved in 2015 as D6890 – 15b. DOI: 10.1520/D6890-16E01.

² This test method is based on IP PM CQ/2001, published in the IP Standard Methods for Analysis and Testing of Petroleum and Related Products and British Standard 2000 Parts. Copyrighted by Energy Institute, 61 New Cavendish Street, London, W1G 7AR, UK. Adapted with permission of Energy Institute.

last right-hand digit used in expressing the parameter, in accordance with the rounding method of Practice E29.

1.5 The values stated in SI units are to be regarded as standard. No other units of measurement are included in this standard.

1.6 *This standard does not purport to address all of the safety concerns, if any, associated with its use. It is the responsibility of the user of this standard to establish appropriate safety and health practices and determine the applicability of regulatory limitations prior to use.*

1.7 *This international standard was developed in accordance with internationally recognized principles on standardization established in the Decision on Principles for the Development of International Standards, Guides and Recommendations issued by the World Trade Organization Technical Barriers to Trade (TBT) Committee.*

2. Referenced Documents

2.1 ASTM Standards:³

- D613 Test Method for Cetane Number of Diesel Fuel Oil
- D975 Specification for Diesel Fuel Oils
- D1193 Specification for Reagent Water
- D4057 Practice for Manual Sampling of Petroleum and Petroleum Products
- D4175 Terminology Relating to Petroleum Products, Liquid Fuels, and Lubricants
- D4177 Practice for Automatic Sampling of Petroleum and Petroleum Products
- D5854 Practice for Mixing and Handling of Liquid Samples of Petroleum and Petroleum Products
- D6299 Practice for Applying Statistical Quality Assurance and Control Charting Techniques to Evaluate Analytical Measurement System Performance
- D6300 Practice for Determination of Precision and Bias

³ For referenced ASTM standards, visit the ASTM website, www.astm.org, or contact ASTM Customer Service at service@astm.org. For *Annual Book of ASTM Standards* volume information, refer to the standard’s Document Summary page on the ASTM website.

*A Summary of Changes section appears at the end of this standard

Data for Use in Test Methods for Petroleum Products and Lubricants

D6708 Practice for Statistical Assessment and Improvement of Expected Agreement Between Two Test Methods that Purport to Measure the Same Property of a Material

E29 Practice for Using Significant Digits in Test Data to Determine Conformance with Specifications

E456 Terminology Relating to Quality and Statistics

2.2 *ISO Standards*:⁴

ISO 4010 Diesel Engines—Calibrating Nozzle, Delay Pintle Type

ISO 4259 Petroleum products—Determination and application of precision data in relation to methods of test

2.3 *EN Standard*:

EN 590 Automotive Fuels—Diesel—Requirements and Test Methods⁵

2.4 *Energy Institute Standard*:

IP 41 Ignition Quality of Diesel Fuels—Cetane Engine Test Method⁶

2.5 *Canadian Standards*:⁷

CAN/CGSB-3.517 Diesel Fuel

CAN/CGSB 3.520 Diesel Fuel Containing Low Levels of Biodiesel (B1–B5)

3. Terminology

3.1 Definitions:

3.1.1 *accepted reference value (ARV)*, *n*—value that serves as an agreed-upon reference for comparison and that is derived as (1) a theoretical or established value, based on scientific principles, (2) an assigned value, based on experimental work of some national or international organization, such as the U.S. National Institute of Standards and Technology (NIST), or (3) a consensus value, based on collaborative experimental work under the auspices of a scientific or engineering group. **E456**

3.1.1.1 *Discussion*—In the context of this test method, accepted reference value is understood to apply to the ignition delay of specific reference materials determined under reproducibility conditions by collaborative experimental work.

3.1.2 *biodiesel*, *n*—fuel comprised of mono-alkyl esters of long chain fatty acids derived from vegetable oils or animal fats, designated B100.

3.1.3 *biodiesel blend (BXX)*, *n*—blend of biodiesel fuel with diesel fuel oils.

3.1.3.1 *Discussion*—In the abbreviation, BXX, the XX represents the volume percentage of biodiesel fuel in the blend.

3.1.4 *cetane number (CN)*, *n*—a measure of the ignition performance of a diesel fuel oil obtained by comparing it to reference fuels in a standardized engine test. **D4175**

⁴ Available from American National Standards Institute, 25 W. 43rd St., 4th floor, New York, NY 10036.

⁵ Available from European Committee for Standardization. Central Secretariat: rue de Stassart, 36, B-1050 Brussels, Belgium.

⁶ Available from Institute of Petroleum, 61 New Cavendish St., London, W1G 7AR, U.K.

⁷ Available from Canadian General Standards Board (CGSB), 11 Laurier St., Phase III, Place du Portage, Gatineau, Quebec K1A 0S5, Canada, <http://www.tpsgc-pwgsc.gc.ca/ongc-cgsb>.

3.1.4.1 *Discussion*—In the context of this test method, cetane number is that defined by Test Method **D613/IP 41**.

3.1.5 *check standard, n—in QC testing*, material having an accepted reference value used to determine the accuracy of a measurement system. **D6299**

3.1.5.1 *Discussion*—In the context of this test method, check standard refers to heptane.

3.1.6 *hydrocarbon oil, n*—a homogeneous mixture with elemental composition primarily of carbon and hydrogen that may also contain sulfur, oxygen, or nitrogen from residual impurities and contaminants associated with the fuel's raw materials and manufacturing processes and excluding added oxygenated materials.

3.1.6.1 *Discussion*—Neither macro nor micro emulsions are included in this definition since neither are homogeneous mixtures.

3.1.6.2 *Discussion*—Examples of excluded oxygenated materials are alcohols, esters, ethers, and triglycerides.

3.1.6.3 *Discussion*—The hydrocarbon oil may be manufactured from a variety of raw materials, for example petroleum (crude oil), oil sands, natural gas, coal, and biomass.

3.1.7 *quality control (QC) sample, n*—for use in quality assurance programs to determine and monitor the precision and stability of a measurement system, a stable and homogeneous material having physical or chemical properties, or both, similar to those of typical samples tested by the analytical measurement system. The material is properly stored to ensure sample integrity, and is available in sufficient quantity for repeated, long term testing. **D6299**

3.2 Definitions of Terms Specific to This Standard:

3.2.1 *calibration reference material, n*—pure chemical having an assigned ignition delay accepted reference value.

3.2.2 *charge air, n*—compressed air at a specified pressure introduced to the combustion chamber at the beginning of each test cycle.

3.2.3 *charge air temperature, n*—temperature, in °C, of the air inside the combustion chamber.

3.2.4 *combustion analyzer, n*—integrated compression ignition apparatus to measure the ignition characteristics of diesel fuel oil.

3.2.5 *derived cetane number (DCN)*, *n*—a number calculated using a conversion equation to determine a cetane number.

3.2.5.1 *Discussion*—The conversion equation relates a measured ignition delay or ignition delay and combustion delay from a combustion analyzer to a cetane number.

3.2.6 *ignition delay (ID)*, *n*—that period of time, in milliseconds (ms), between the start of fuel injection and the start of combustion as determined using the specific combustion analyzer applicable for this test method.

3.2.6.1 *Discussion*—In the context of this test method, start of fuel injection is interpreted as the initial movement or lift of the injector nozzle needle as measured by a motion sensor; start of combustion is interpreted as that point in the combustion

cycle when a significant and sustained increase in rate-of-change in pressure, as measured by a pressure sensor in the combustion chamber, ensures combustion is in progress.

3.2.7 *operating period, n*—the time, not to exceed 12 h, between successive calibration or QC testing, or both, of the combustion analyzer by a single operator.

3.3 Abbreviations:

3.3.1 *ARV*—accepted reference value.

3.3.2 *CN*—cetane number.

3.3.3 *DCN*—derived cetane number.

3.3.4 *ID*—ignition delay.

3.3.5 *QC*—quality control.

4. Summary of Test Method

4.1 A small specimen of diesel fuel oil is injected into a heated, temperature-controlled constant volume chamber, which has previously been charged with compressed air. Each injection produces a single-shot, compression ignition combustion cycle. ID is measured using sensors that detect the start of fuel injection and the start of significant combustion for each cycle. A complete sequence comprises 15 preliminary cycles and 32 further cycles. The ID measurements for the last 32 cycles are averaged to produce the ID result. An equation converts the ID result to DCN (derived cetane number), which is correlated to cetane number by Test Method D613.

5. Significance and Use

5.1 The ID and DCN values determined by this test method can provide a measure of the ignition characteristics of diesel fuel oil in compression ignition engines.

5.2 This test can be used in commerce as a specification aid to relate or match fuels and engines. It can also be useful in research or when there is interest in the ignition delay of a diesel fuel under the conditions of this test method.

5.3 The relationship of diesel fuel oil DCN determinations to the performance of full-scale, variable-speed, variable-load diesel engines is not completely understood.

5.4 This test may be applied to non-conventional fuels. It is recognized that the performance of non-conventional fuels in full-scale engines is not completely understood. The user is therefore cautioned to investigate the suitability of ignition characteristic measurements for predicting performance in full-scale engines for these types of fuels.

5.5 This test determines ignition characteristics and requires a sample of approximately 100 mL and a test time of approximately 20 min on a fit-for-use instrument.

6. Interferences

6.1 Minimize exposure of sample fuels, calibration reference materials, QC samples, and check standard to sunlight or fluorescent lamp UV emissions to minimize induced chemical reactions that can affect ignition delay measurements.⁸

⁸ Supporting data have been filed at ASTM International Headquarters and may be obtained by requesting Research Report RR:D02-1502.

6.1.1 Exposure of these fuels and materials to UV wavelengths shorter than 550 nanometers for a short period of time may significantly affect ignition delay measurements.

NOTE 1—The formation of peroxide and radicals can effect ignition delay measurement. These formations are minimized when the sample or material is stored in the dark in a cold room at a temperature of less than 10°C, and covered by a blanket of nitrogen.

6.2 Statistical analysis of data from a sequential testing study (Note 2) revealed a possible carryover effect in succeeding tests on samples containing 2-ethylhexylnitrate cetane improver at concentrations above 2000 ppm.

NOTE 2—In the sequential testing study, a fuel without cetane improver was tested three times back-to-back. Then a fuel with 2-ethylhexylnitrate cetane improver at concentrations above 2000 ppm was tested. Subsequently, the same fuel without cetane improver was tested three times. Statistical analyses of repeat data on two units were examined for evidence of hysteresis.

7. Apparatus

7.1 *General*—This test method uses an integrated automated analytical measurement system⁹ comprised of: (1) a constant volume compression ignition combustion chamber with external electrical heating elements, suitable insulation and pneumatically actuated intake and exhaust valves, (2) a heated, pneumatically actuated fuel injection system¹⁰ with pump, injector nozzle assembly, and associated sample reservoir, (3) a coolant system with a liquid-to-air heat exchanger, filter, circulating pump and flow control valves, (4) temperature thermocouples, pressure gages and sensors, an injector nozzle needle motion sensor, compressed gas pressure regulators, control valves, pneumatic actuator components, and solenoid valves, and (5) a computer to control test sequencing, acquire and accumulate sensor signal data, provide processing calculations, and automatically output a printed report of some important test parameters (see Fig. 1).

7.2 See Annex A2, Combustion Analyzer Equipment Description and Specifications, for detailed information.

7.3 Compressed Gas Pressure Regulators:

7.3.1 *Charge Air Regulator*, a two-stage regulator capable of controlling the downstream pressure to a minimum pressure of 2.2 MPa.

7.3.2 *Actuator Utility Compressed Air Regulator*, a two-stage regulator capable of controlling the downstream pressure to a minimum pressure of 1.3 MPa.

7.3.3 *Fuel Reservoir Utility Compressed Nitrogen Regulator*, a single or two-stage regulator capable of controlling the downstream pressure to a minimum pressure of 350. kPa.

⁹ The sole source of supply of the combustion analyzer known to the committee at this time is Advanced Engine Technology Ltd. (AET), 17 Fitzgerald Road, Suite 102, Ottawa, Canada, K2H 9G1. If you are aware of alternative suppliers, please provide this information to ASTM International Headquarters. Your comments will receive careful consideration at a meeting of the responsible technical committee,¹ which you may attend.

¹⁰ The fuel injection system is covered by a patent. Interested parties are invited to submit information regarding the identification of an alternative(s) to this patented item to the ASTM International Headquarters. Your comments will receive careful consideration at a meeting of the responsible technical committee,¹ which you may attend.

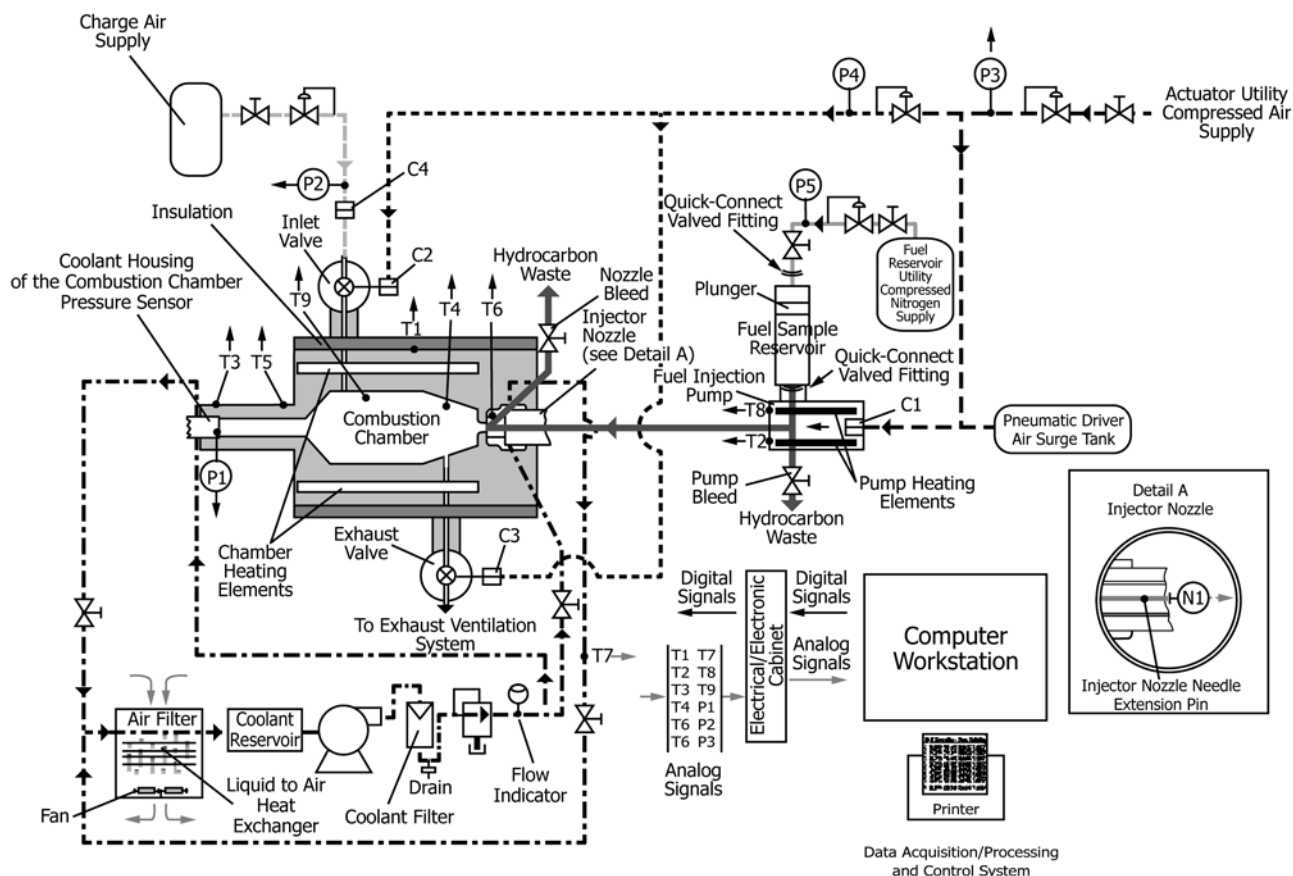

Legend

- P1: Combustion Chamber Pressure
- P2: Charge Air Pressure
- P3: Injection Actuator Air Pressure
- P4: Inlet/Exhaust Valve Actuator Air Pressure (Gauge)
- P5: Sample Fuel Reservoir Pressure (Gauge)
- T1: Combustion Chamber Outer Surface Temperature
- T2: Fuel Injection Pump Temperature
- T3: Combustion Chamber Pressure Sensor Temperature
- T4: Charge Air Temperature
- T5: (Used for diagnostic functions)

- T6: Injector Nozzle Coolant Passage Temperature
- T7: Coolant Return Temperature
- T8: (Used for diagnostic functions)
- T9: Combustion Chamber Air Back Temperature
- N1: Injector Nozzle Needle Motion Sensor
- C1: Digital Signal – Fuel injection Actuator
- C2: Digital Signal – Inlet Valve Actuator
- C3: Digital Signal – Exhaust Valve Actuator
- C4: Digital Signal – Charge Air Valve Actuator

- : Charge Air Line
- : Inlet/Exhaust Valve Actuator Air Line
- : Fuel Reservoir Utility Nitrogen Line

- : Fuel Injection Pump Driver Air Line
- : Coolant System Line
- : High Pressure Fuel Line

FIG. 1 Combustion Analyzer Schematic

7.4 Auxiliary Apparatus:

7.4.1 *Diesel Fuel Oil Sample Filter*; a single-use glass fiber, polytetrafluorethylene (PTFE), or nylon filter with a nominal pore size of 3 μm to 5 μm for use with a positive pressure delivery device such as a glass syringe or glass-lined metal syringe.

7.4.2 *Positive Pressure Delivery Device*, a non-reactive positive pressure delivery device such as a glass syringe or a glass-lined metal syringe.

8. Reagents and Materials

8.1 Calibration Reference Materials:

8.1.1 *Heptane (n-heptane)*, with a minimum purity of 99.5 volume percent. The assigned ID_{ARV} for this material is 3.78 ms. (**Warning**—Flammable. Vapor harmful. Vapor may cause flash fire.)

8.1.2 *Methylcyclohexane (MCH)*, with a minimum purity of 99.0 volume percent. The assigned ID_{ARV} for this material is 10.4 ms. (**Warning**—Flammable. Vapor harmful. Vapor may cause flash fire.)

NOTE 3—Experience has found some MCH meeting the purity specification but which does not meet Ignition Delay $_{ARV}$ (typically 1 millisecond to 1.5 milliseconds shorter). It is recommended that new material be qualified prior to use.

8.2 Check Standard:

8.2.1 *Heptane (n-heptane)*, with a minimum purity of 99.5 volume percent. The assigned ID_{ARV} for this material is 3.78 ms. (**Warning**—Flammable. Vapor harmful. Vapor may cause flash fire.)

8.3 *Quality Control Sample*, a stable and homogeneous diesel fuel oil having physical and chemical properties similar

to those of typical sample fuels routinely tested. (**Warning**—Combustible. Vapor harmful.)

8.4 *Charge Air*, compressed air containing 19.9 volume percent to 21.9 volume percent oxygen, less than 0.003 volume percent hydrocarbons, and less than 0.025 volume percent water. For charge air cylinders supplied with a blend of oxygen and nitrogen, it is required that a quality control test be performed after an air cylinder has been changed. (**Warning**—Compressed gas under high pressure that supports combustion.)

8.5 *Coolant System Fluid*, a 50:50 volume mixture of water and commercial ethylene glycol-based antifreeze. (**Warning**—Poison. May be harmful or fatal if inhaled or swallowed.)

8.5.1 *Antifreeze*, commercial automotive cooling system ethylene glycol-based solution.

8.5.2 *Water*, distilled or reagent-grade, conforming to Specification **D1193**, Type IV.

8.6 *Actuator Utility Compressed Air*, oil free compressed air having less than 0.1 volume percent water supplied at a minimum sustained pressure of 1.5 MPa. (**Warning**—Compressed gas under high pressure that supports combustion.)

8.7 *Fuel Reservoir Utility Compressed Nitrogen*, compressed nitrogen having a minimum purity of 99.9 volume percent. (**Warning**—Compressed gas under high pressure.)

9. Sampling and Test Specimen Preparation

9.1 Sampling:

9.1.1 Collect diesel fuel oil samples in accordance with Practices **D4057** or **D4177**.

9.1.1.1 Collect and store diesel fuel samples in a suitable container such as a dark brown bottle, a metal can, or a minimally reactive plastic container to minimize exposure to UV emissions.

9.1.2 Refer to Practice **D5854** for appropriate information relating to the mixing and handling of diesel fuel oil samples.

9.2 Test Specimen Preparation:

9.2.1 *Sample Fuel Temperature*—Condition the diesel fuel sample before opening the storage container, so that it is at room temperature, typically 18 °C to 32 °C.

9.2.2 *Filtration*—Prepare a test specimen by filtering diesel fuel oil of sufficient volume to complete the test method, including flushing, through a nominal 3 μm to 5 μm porosity filter element using a positive pressure delivery device such as a glass syringe or a glass-lined metal syringe.

9.2.2.1 Collect the specimen in a dark brown bottle, metal can or minimally reactive plastic container.

10. Basic Apparatus Settings and Standard Operating Conditions

10.1 Installation of the apparatus requires placement on a level floor and connection of all utilities. Engineering and technical support for this function is required, and the user shall be responsible to comply with all local and national codes and installation requirements.

10.2 Operation of the combustion analyzer, associated equipment, instrumentation and computer system requires

setting a series of testing variables to prescribed specifications. Some of these settings are established by component specifications, others are operating conditions that are monitored/controlled by the computer software or by operator adjustment.

10.3 Settings Based on Component Specifications:

10.3.1 *Injector Nozzle Opening Pressure*—Each time the nozzle assembly is reassembled or replaced, or both, set the pressure-adjusting nut to release fuel in conformance with the requirements in the manufacturer's equipment manual, using an injector nozzle tester. For additional details, refer to the instruction manual of the manufacturer.

10.3.2 *Injector Nozzle Motion Sensor Position*—Manually position the motion sensor while visually observing the nozzle needle movement signal on the computer monitor (see **Fig. A4.1**). The criteria for optimized setting are as follows:

10.3.2.1 The signal prior to the steep increase in needle lift is required to indicate some signal noise. If the signal trace is flat and constant, the motion sensor is too far away from the nozzle needle extension pin.

10.3.2.2 The peak of the steep increase in signal level is required to be visible on the computer monitor screen. If the signal peak is flat, the motion sensor is too close to the nozzle needle extension pin. For additional details, refer to the instruction manual of the manufacturer.

10.3.3 *Injector Nozzle Coolant Passage Thermocouple Position*—Proper positioning of the thermocouple in the injector nozzle coolant passage is set by installing a compression fitting nut and associated plastic ferrule on the stainless steel sheath of the thermocouple, using a specialized depth setting tool to establish the correct depth of penetration. Adjust the depth of penetration (in accordance with the instruction manual of the manufacturer) by repositioning the plastic ferrule on the stainless steel sheath of the thermocouple and tightening the nut to a snug level of tightness. For additional details, refer to the instruction manual of the manufacturer.

10.3.4 *Charge Air Thermocouple Position*—Proper positioning of the thermocouple in the combustion chamber is set by installing a compression fitting nut and associated ferrule on the stainless steel sheath of the thermocouple, crimping the ferrule on the sheath using a specialized depth setting tool to establish the correct depth of penetration. For additional details, refer to the instruction manual of the manufacturer.

10.3.5 *Rate of Decrease of Combustion Chamber Pressure*, less than 3.5 kPa/s, as measured during the check of the sealing integrity of the combustion chamber (see **A3.5**).

10.4 Standard Operating Conditions:

10.4.1 *Charge Air Pressure (P₂)*, 2.130 MPa to 2.144 MPa.

10.4.2 *Charge Air Temperature (T₄)*, 515 °C to 575 °C.

10.4.2.1 The difference in temperature ($T_{4_{max}} - T_{4_{min}}$) as determined and recorded by the computer, shall be less than 2.5 °C during a 32 combustion cycle measurement determination.

10.4.3 *Combustion Chamber Outer Surface Temperature (T_I)*—Initially set by the manufacturer, the surface temperature is monitored and controlled by the computer. Operator adjustment of the controller set-point is required, in accordance with the calibration procedure.

10.4.4 *Combustion Chamber Pressure Sensor Temperature* (T_3), 110. °C to 150. °C.

10.4.4.1 The difference in temperature ($T_{3_{max}} - T_{3_{min}}$) as determined and recorded by the computer, shall be less than 8.0 °C during a 32 combustion cycle measurement determination.

10.4.5 *Coolant Return Temperature* (T_7), 30. °C to 50. °C.

10.4.6 *Fuel Sample Reservoir Pressure* (P_5), 310. kPa to 380. kPa. Visually check the gage reading, as this parameter is not recorded by the data acquisition system.

10.4.7 *Fuel Injection Pump Temperature* (T_2), 32 °C to 38 °C.

10.4.8 *Injector Nozzle Coolant Passage Temperature* (T_6)—The maximum ($T_{6_{max}}$) and minimum ($T_{6_{min}}$) temperatures as determined and recorded by the computer, shall be within 46.0 °C ± 54.0 °C during a 32 combustion cycle measurement determination.

10.4.9 *Injection Actuator Air Pressure* (P_3), 1.18 MPa to 1.24 MPa.

10.4.10 *Inlet/Exhaust Valve Actuator Air Pressure* (P_4), 445 kPa to 515 kPa. Visually check the gage reading, as this parameter is not recorded by the data acquisition system.

11. Calibration and Quality Control Testing

11.1 *Calibration*—Calibrate the combustion analyzer for only the following reasons: (1) after it is installed and commissioned, (2) after replacement of critical parts or components of combustion chamber assembly (see A2.2), fuel injection system (see A2.3) or instrument sensors (see A2.4), (3) after calibration of the data acquisition board, injection actuator air pressure sensor or charge air pressure sensor, (4) whenever check standard or QC sample determinations are not in statistical control as determined by Practice D6299 or equivalent and the assignable causes for QC non-compliance have been suitably addressed.

11.2 *Precalibration Procedures:*

11.2.1 Clean the combustion chamber pressure sensor assembly (see A3.3 and A3.4).

11.2.2 If necessary, start and warm-up the combustion analyzer (see A3.1).

11.3 *Calibration Procedure*—Two filtered calibration reference materials are tested: (1) heptane to affirm that the combustion chamber charge air temperature setting produces ignition delay measurements for this material that are within specification limits and, (2) methylcyclohexane to affirm that the measurement sensitivity of the combustion analyzer produces ignition delay measurements for this material that are within specification limits.

11.3.1 *Heptane Calibration Reference Material*—Perform three consecutive ignition delay determinations.

11.3.1.1 The average of three acceptable ID results is required to be within 3.77 ms to 3.79 ms.

11.3.1.2 If the average ID is outside the limits, the combustion chamber outer surface temperature controller set-point requires adjustment to cause a change in the combustion chamber charge air temperature.

NOTE 4—ID increases when the combustion chamber outer surface temperature decreases and vice versa.

11.3.1.3 If the temperature controller set-point adjustment from the previous setting, exceeds ±4 °C, a system malfunction is suspected and diagnostic procedures to determine and remedy the problem are recommended. Refer to the instructions provided by the manufacturer.

NOTE 5—After a change of charge air cylinders that employ a blend of oxygen and nitrogen, a temperature controller set-point adjustment beyond 4 °C can accommodate the extreme limits of the 19.9 volume percent to 21.9 volume percent oxygen in the blend.

11.3.1.4 After a temperature controller set-point adjustment, wait at least 10. min before initiating a new calibration so that the combustion analyzer attains thermal equilibrium.

11.3.1.5 To be an acceptable data set, each single result is required to be within 3.72 ms to 3.84 ms.

11.3.1.6 If any of the three results is outside the limits, a system malfunction is suspected and diagnostic procedures to determine and remedy the problem are recommended before performing a new calibration. Refer to the instructions provided by the manufacturer.

11.3.2 *Methylcyclohexane Calibration Reference Material*—Perform two consecutive ignition delay determinations.

11.3.2.1 To be an acceptable data set, each single result is required to be within 9.8 ms to 11.0 ms and the average of the two results is required to be within 9.9 ms to 10.9 ms.

11.3.2.2 If either of the two single results or the average of the two results is outside the respective limits, system performance is unacceptable and it is recommended that diagnostic procedures be used to determine and remedy the problem before performing a new calibration. Refer to the instructions provided by the manufacturer.

11.3.3 The combustion analyzer calibration is complete when both heptane and methylcyclohexane data sets are acceptable.

11.4 *Quality Control (QC Testing)*—Conduct a regular statistical quality assurance (quality control) program in accordance with the techniques of Practice D6299 or equivalent.

11.4.1 This test method requires quality control testing at the beginning of each operating period by a single ignition delay determination for both the check standard (heptane) and one QC sample.

11.4.2 The QC sample is a typical diesel fuel oil having an ignition delay that represents the primary range of use for the combustion analyzer.

11.4.2.1 If the combustion analyzer is used for testing fuels having a very wide range of ignition delay, it may be useful to have a second QC sample of a different ignition delay.

11.4.3 For locations using blends of oxygen and nitrogen as the source for charge air, conduct a QC test whenever there is a change from one cylinder to another.

NOTE 6—The oxygen content of the new oxygen and nitrogen blend may differ from that of the previous source and can have a significant effect on ID measurements.

11.5 *Check Standard*—Perform a single ignition delay determination for filtered heptane.

11.5.1 This determination is acceptable if it satisfies the limits protocol specified in Practice D6299 or equivalent.

11.5.2 Prior to having established ignition delay tolerances for heptane in accordance with Practice **D6299** or equivalent, use warning limits of ± 0.07 ms and action limits of ± 0.106 ms, based on the average of the three acceptable ID results for heptane, as per **11.3.1**.

NOTE 7—The warning and action limits for heptane were determined by analysis of round robin test data.¹¹

11.6 *QC Sample*—Perform a single ignition delay determination for the filtered QC sample.

11.6.1 This determination is acceptable if it satisfies the limits protocol specified in Practice **D6299** or equivalent.

11.7 The combustion analyzer is fit-for-use when both the check standard (heptane) and the QC sample ignition delay determinations are acceptable. If the ignition delay determination for either material is not acceptable, conduct a new calibration before performing further ignition delay determinations.

12. Procedure

12.1 *Operating Period Procedure:*

12.1.1 If necessary, warm-up the combustion analyzer (see **A3.1**).

12.1.2 Check the sealing integrity of the combustion chamber (see **A3.5**).

12.1.3 Check that the combustion analyzer is fit-for use by performing a quality control test (see **11.4**).

12.2 *Test Procedure:*

12.2.1 Filter the diesel fuel sample at room temperature, using a non-reactive positive pressure delivery device such as a glass syringe or glass-lined metal syringe and single-use filter element, to prepare a test specimen of sufficient volume to complete the test method, including flushing. The recommended volume for most test purposes is 100 mL. See the instructions provided by the manufacturer for further information.

12.2.2 Flush, fill, and purge the fuel system with the specimen (see **A3.2.2**).

12.2.3 Initiate an automatic ignition delay determination using the appropriate computer command (see **Annex A4** for detailed information about the test sequence).

12.2.4 Check that all standard operating conditions are in compliance.

12.2.5 If operating conditions are not in compliance, make the required adjustments and return to **12.2.2**.

12.2.6 Record the average ignition delay to the nearest 0.001 ms for the calculation of the DCN (**13.1**).

12.3 Discharge unused specimen and clean the fuel system (see **A3.2.3** or **A3.2.4**) to prepare for (1) the next specimen determination, or (2) combustion analyzer shut down (see **A3.6**).

¹¹ Supporting data have been filed at ASTM International Headquarters and may be obtained by requesting Research Report RR:D02-1532.

13. Calculation

13.1 Calculate the derived cetane number, DCN, from average ignition delay, ID (ms), recorded as in **12.2.6** using **Eq 1**:¹²

$$DCN = 4.460 + 186.6/ID \quad (1)$$

13.2 Record the DCN to the nearest 0.1.

13.3 The derivation and maintenance of **Eq 1** is described in **Annex A5**.

14. Report

14.1 Report the following information:

14.1.1 A reference to this standard,

14.1.2 The sample identification,

14.1.3 The date of the test,

14.1.4 The ID result to the nearest hundredth (0.01 ms),

14.1.5 The DCN result to the nearest tenth (0.1),

14.1.6 The test's average charge air temperature to the nearest tenth (0.1) °C, and

14.1.7 Any deviation, by agreement or otherwise, from the specified procedures.

15. Precision and Bias

15.1 *General*—The precision statements for ID and DCN are based on an interlaboratory study conducted in 2002 (RR:D02-1602¹²), supplemented by interlaboratory results reported to the ASTM National Exchange Group and the Energy Institute in their monthly diesel exchanges between January 2004 and July 2009 (RR:D02-1700¹³). The test results for the study were statistically analyzed using ASTM Practice **D6300**/ISO 4259 techniques and involved, from the 2002 round robin, 10 laboratories and 15 test samples, and from the exchanges, 34 laboratories and 145 samples. The totality of samples covered the ID range from 3.24 ms to 6.24 ms (DCN range from 62.0 DCN to 34.4 DCN).

NOTE 8—The DCN and its precision have been calculated from ignition delay results using **Eq 1**.

15.2 *Precision:*

15.2.1 *Repeatability*—The difference between successive results obtained by the same operator with the same apparatus, under constant operating conditions, on identical test materials would, in the long run, in the normal and correct operation of the test method, exceed the values calculated using the mathematical expressions in **Table 1** only in one case in twenty.

¹² Supporting data have been filed at ASTM International Headquarters and may be obtained by requesting Research Report RR:D02-1602.

¹³ Supporting data have been filed at ASTM International Headquarters and may be obtained by requesting Research Report RR:D02-1700.

TABLE 1 Repeatability (r) and Reproducibility (R) for Ignition Delay (ID) and Derived Cetane Number (DCN)

	ID (ms)	DCN
Repeatability (r)	$0.0500 \times (ID - 2.5)$	$0.0132 \times (DCN + 18)$
Reproducibility (R)	$0.0792 \times (ID - 1.1)$	$0.0385 \times (DCN + 18)$

15.2.2 *Reproducibility*—The difference between two single and independent results, obtained by different operators working in different laboratories on identical test materials, would, in the long run, and in the normal and the correct operation of the test method, exceed the values calculated using the mathematical expressions in [Table 1](#) only in one case in twenty.

15.2.3 Examples of repeatability and reproducibility are shown in [Table 2](#) for user information.

15.3 *Bias*—The ID determined using this test method has no bias because ID is defined only in terms of this test method.

15.4 *Relative Bias to Test Method D613*—The degree of expected agreement between DCN results by this test method and CN results by Test Method [D613](#) has been assessed in accordance with Practice [D6708](#) using the interlaboratory studies conducted in 2002 and the 2004–2009 Energy Institute IP and 2004–2009 NEG correlation schemes.

TABLE 2 Repeatability and Reproducibility Values for Information

ID (ms)	Repeatability (r)	Reproducibility (R)
3.1	0.030	0.158
3.6	0.055	0.198
4.2	0.085	0.246
4.8	0.115	0.293
6.0	0.175	0.388
6.5	0.200	0.428
DCN	Repeatability (r)	Reproducibility (R)
33	0.67	1.96
40	0.77	2.23
45	0.83	2.43
50	0.90	2.62
55	0.96	2.81
60	1.03	3.00
64	1.08	3.16

15.4.1 No bias correction considered in Practice [D6708](#) can further improve the agreement between results from Test Method [D6890](#) and Test Method [D613](#). Sample specific bias, as defined in Practice [D6708](#), was observed for some samples.

15.4.2 *Reproducibility Limit between a Single DCN Result versus a Single CN_{D613} Result*:

15.4.2.1 Differences between results from Test Method [D6890](#) and Test Method [D613](#), for the same types and property ranges studied, are expected to exceed the following between methods reproducibility (R_{xy}) as defined in Practice [D6708](#), about 5 % of the time.

15.4.2.2 As a consequence of sample-specific biases observed, the 95 % confidence limit on the differences between a single DCN result and a CN_{D613} result can be expected to be larger than the reproducibility of either test method. Users are advised to assess the required degree of prediction agreement relative to the estimated R_{xy} to determine the fitness-for-use of the prediction.

15.4.2.3 Based on the results from the interlaboratory study, the difference between the single DCN result and a single CN_{D613} result, over the long-term and correct operation of both test methods, for any sample meeting the scope of both test methods, is estimated to exceed the values calculated in [Eq 2](#) no more than one case in twenty.

$$R_{xy} = 0.1094 \times [(DCN + CN_{D613})/2 - 11.02] \quad (2)$$

15.4.2.4 Examples of between-methods reproducibility (R_{xy}) are shown in [Table 3](#) for user information.

16. Keywords

16.1 cetane number; derived cetane number; diesel performance; ignition characteristic; ignition delay

TABLE 3 Between Test Methods Reproducibility (R_{xy})

= (DCN + CN _{D613})/2	Reproducibility
33.0	2.40
40.0	3.17
45.0	3.72
50.0	4.26
55.0	4.81
60.0	5.36
64.0	5.80

ANNEXES

(Mandatory Information)

A1. HAZARDS INFORMATION

A1.1 Introduction

A1.1.1 In the performance of the standard test method there are hazards to personnel. These are indicated in the text. For more detailed information regarding the hazards, refer to the appropriate Material Safety Data Sheet (MSDS) for each of the applicable substances to establish risks, proper handling, and safety precautions.

A1.2 (**Warning**—Combustible. Vapor harmful.)

A1.2.1 *Applicable Substances:*

A1.2.1.1 Diesel fuel oil, and

A1.2.1.2 Quality control sample.

A1.3 (**Warning**—Flammable. Vapors harmful if inhaled. Vapors may cause flash fire.)

A1.3.1 *Applicable Substances:*

A1.3.1.1 Heptane, and

A1.3.1.2 Methylcyclohexane.

A1.4 (**Warning**—Poison. May be harmful or fatal if inhaled or swallowed.)

A1.4.1 *Applicable Substances:*

A1.4.1.1 Ethylene glycol based antifreeze.

A1.5 (**Warning**—Compressed gas under high pressure that supports combustion.)

A1.5.1 *Applicable Substances:*

A1.5.1.1 Compressed air.

A1.6 (**Warning**—Compressed gas under high pressure.)

A1.6.1 *Applicable Substances:*

A1.6.1.1 Compressed nitrogen.

A1.7 (**Warning**—Hot surfaces.)

A1.7.1 *Applicable Substances:*

A1.7.1.1 Protective cage enclosing the combustion chamber,

A1.7.1.2 Exposed areas of the combustion chamber around the injector nozzle, and

A1.7.1.3 Exposed areas of the combustion chamber near the combustion chamber inside the combustion chamber protective cage.

A2. COMBUSTION ANALYZER EQUIPMENT DESCRIPTION AND SPECIFICATIONS

A2.1 The combustion chamber assembly and fuel injection system are critical to the proper operation of this test method.

A2.2 *Combustion Chamber Assembly*—The principle component of this assembly, illustrated in Fig. A2.1, is a corrosion-protected metal cylindrical block that is precision machined and fabricated to include the following features:

A2.2.1 A cavity along a central axis of the body, having a volume of 0.211 L to 0.215 L, that constitutes the compression ignition combustion chamber.

A2.2.2 An opening at one end of the chamber to accommodate insertion of the fuel injection nozzle assembly and which

includes a passage for circulation of liquid coolant to control the injector nozzle temperature.

A2.2.3 An opening at the other end of the chamber, to accommodate insertion of a pressure sensor liquid-cooled housing.

A2.2.4 Two drilled ports or passages between the combustion chamber cavity and the external surface of the assembly to accommodate an inlet and an exhaust valve.

A2.2.5 Nine passages, drilled from the pressure sensor end of the block, parallel to the chamber axis, to accept individual electric heating elements.

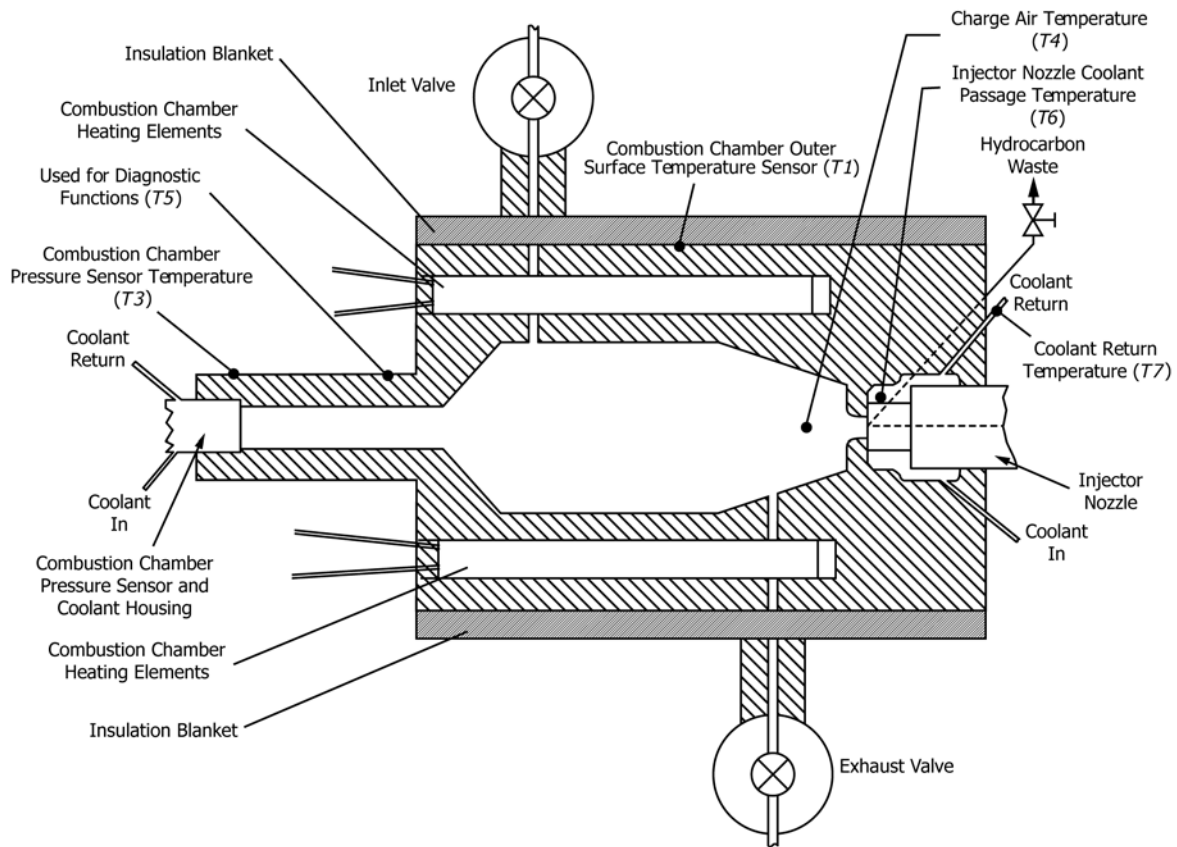

FIG. A2.1 Combustion Chamber Schematic

A2.2.6 A series of wells or drilled passages to accommodate temperature sensor elements.

A2.2.7 An external insulation blanket to minimize heat loss from the block and improve heat distribution inside the combustion chamber cavity.

A2.2.8 An inlet valve assembly that includes a digital signal controlled solenoid valve to operate a pneumatically actuated, servo-type valve connected to the inlet port.

A2.2.9 An exhaust valve assembly that includes a digital signal controlled solenoid valve to operate a pneumatically actuated, servo-type valve connected to the exhaust port.

A2.2.10 *Combustion Chamber Heating Elements*, nine cartridge-type resistance heaters.

A2.3 *Fuel Injection System*,¹⁰ a patented, integrated assembly of components for proper and repeatable injection of calibration reference material, QC sample fuel, check standard, and test specimens into the combustion chamber. The system includes:

A2.3.1 *Fuel Sample Reservoir Assembly*, a corrosion-protected metal reservoir having a minimum volume of 36 mL without the fuel reservoir plunger installed in the reservoir, a threaded cap, a fuel resistant, internal, floating plunger with fuel-resistant O-ring to separate the pressurizing gas from the fuel specimens, a quick-connect coupling on the cap for connection to the pressurizing gas source, and a quick-connect

coupling and associated retention pin on the bottom for connection to the fuel injection pump inlet. See Fig. A2.2.

A2.3.2 *Fuel Injection Pump Assembly*, an integrated unit that incorporates a housing with two electric heater elements; a specific constant volume fuel delivery valve; a fuel bleed passage connecting to an external bleed valve for flushing fuel and purging air from the reservoir and fuel injection pump; and a digital controlled three-way solenoid valve that operates a pneumatically-actuated driver mechanism to deliver specimen fuel from the fuel sample reservoir to the injector nozzle and when turned off, discharges air from the driver mechanism to atmosphere.

A2.3.3 *Pneumatic Driver Air Surge Tank*, a tank of a minimum volume of 5.5 L installed in the compressed air line to the pneumatically-actuated fuel pump driver mechanism to minimize pressure fluctuations during the injection process. A suitable protection (that is, pressure relief valves or rupture discs) is installed in the compressed air line to the pneumatically-actuated fuel pump driver mechanism to prevent pressure in the surge tank exceeding 2.4 MPa. The air surge tank shall be pressure tested up to 4.0 MPa in accordance with local regulations.

A2.3.4 *Fuel Injector Nozzle and Body Assembly*, a specific design pintle-type injector nozzle conforming to the requirements of ISO 4010. The nozzle is assembled to the body that incorporates a spring-loaded needle extension with screw and

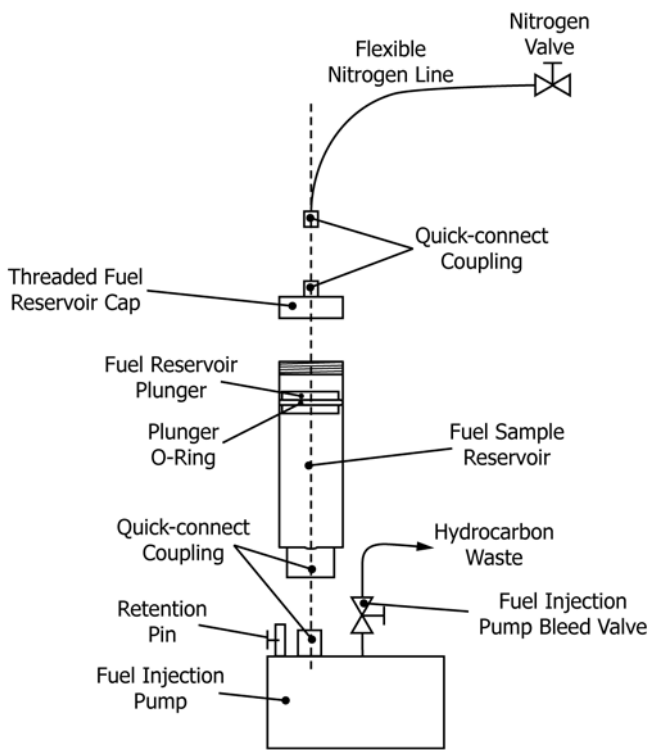

FIG. A2.2 Fuel Reservoir Schematic

lock nut for adjusting the nozzle opening pressure/release setting; a fuel bleed passage connecting to an external bleed valve for bleeding fuel from the nozzle and nozzle body; and an adjusting mechanism that positions a motion sensor near the injector nozzle needle extension pin, to determine when the nozzle needle lifts to initiate the start of injection.

A2.3.5 Fuel Injector Body End Cap, a machined plate with associated gaskets and seals, to clamp the injector nozzle body in the combustion chamber block.

A2.3.6 Fuel Line, high-pressure fuel line with associated fittings connecting the fuel injection pump assembly to the fuel injector body assembly.

A2.4 Instrument Sensors, sensors used to measure and either indicate the value of a variable or transmit the condition for control or data acquisition purposes as follows:

A2.4.1 Combustion Chamber Pressure Sensor (P1), a sensor installed to measure the pressure within the combustion chamber during each testing cycle.

A2.4.2 Charge Air Pressure Sensor (P2), a calibrated pressure sensor installed in the piping between the charge air supply pressure regulator and the combustion chamber inlet valve.

A2.4.3 Injection Actuator Air Pressure Sensor (P3), a calibrated pressure sensor installed in the piping between the utility air supply pressure regulator and the injection pump driver mechanism manual pressure control valve.

A2.4.4 Inlet/Exhaust Valve Actuator Air Pressure Gage (P4), a pressure gage installed in the piping between the inlet/exhaust actuator valves and the associated manual pressure control valve.

A2.4.5 Combustion Chamber Outer Surface Temperature Sensor (T1), a Type K thermocouple with stainless steel sheath, inserted in a well fastened to the outer surface of the block.

A2.4.6 Fuel Injection Pump Temperature Sensor (T2), a Type K thermocouple with stainless steel sheath, inserted in a well of the injection pump body.

A2.4.7 Temperature Sensor Near the Combustion Chamber Pressure Sensor (T3), a Type K thermocouple with stainless steel sheath, inserted in a well fastened to the outer surface of the block, near the combustion chamber pressure sensor.

A2.4.8 Charge Air Temperature Sensor (T4), a Type K thermocouple with stainless steel sheath, inserted in the combustion chamber.

A2.4.9 Injector Nozzle Coolant Passage Temperature Sensor (T6), a Type K thermocouple with stainless steel sheath, inserted in the injector nozzle coolant passage.

A2.4.10 Coolant Return Temperature Sensor (T7), a Type K thermocouple with stainless steel sheath, installed in the coolant return piping of the injector nozzle coolant passage.

A2.4.11 Injector Nozzle Needle Motion Sensor (NI), a motion sensor, that can be adjusted to provide a suitable gap between its sensing surface and the end of injector nozzle needle extension pin to detect the start of fuel injection.

A2.5 Computerized Control, Data Acquisition, Data Analysis and Reporting System, a PC-based computer, signal converters, test sequence control logic, control logic for critical temperatures, computer keyboard for manual entry of operating instructions, a monitor for visual observation of all testing functions, and a printer for printed copy output of test results.

A2.5.1 Computer, PC-type computer compatible with Windows¹⁴ operating system.

A2.5.2 Control System, a computer-based system to provide automated control of the relevant combustion analyzer and sub-system component functions. Electrical and electronic components of the control system are enclosed in a metal electrical/electronic cabinet.

A2.5.3 Data Acquisition/Processing System, a computer-based system with associated instrumentation to collect and process all relevant signals from the injector nozzle needle motion sensor, and temperature and pressure sensors. The system includes an analog-to-digital (A/D) data acquisition board installed in the computer to acquire the output signals from the sensors.

A2.5.4 Signal Conditioning Components, located in a metal electrical/electronic cabinet including signal conditioners for the temperature sensors, the combustion chamber pressure sensor, and the injector nozzle needle motion sensor.

A2.6 Circulating Coolant System

A2.6.1 General, a closed-loop circulating coolant system to control the temperature of the combustion injector nozzle and combustion chamber pressure sensor. The system includes:

¹⁴ Windows is a registered trademark of Microsoft Corporation, One Microsoft Way, Redmond, WA 98052-6399.

A2.6.2 *Coolant Housing*, liquid cooled housing which is capable of fastening the combustion pressure sensor to the combustion chamber and maintaining its temperature within specifications.

A2.6.3 *Coolant Reservoir*, reservoir that is connected to the coolant loop and which contains coolant in addition to the volume in the coolant loop. This excess coolant circulates through the coolant loop as needed to top off any coolant loss.

A2.6.4 *Coolant Pump*, centrifugal pump capable of meeting the pressure and flow requirements of the combustion analyzer.

A2.6.5 *Heat Exchanger*, liquid to air heat exchanger with associated fan and air filter.

A2.6.6 *Coolant Filter*, filter installed in the coolant line, capable of removing foreign particles from the coolant system fluid.

A2.6.7 *Manual Flow Control Valve*, Needle valve used to control the coolant flow to the injector nozzle coolant passage.

A2.7 Optional Equipment

A2.7.1 *UPS*, an electrical unit capable of powering the coolant system fan and pump during a utility power outage.

A3. COMBUSTION ANALYZER OPERATING FUNCTIONS

A3.1 Starting and Warm-up Procedure

A3.1.1 With the combustion analyzer in shut down mode, start a new operating period as follows:

A3.1.1.1 Position the combustion analyzer power switch to ON.

A3.1.1.2 Initiate the automated warm-up sequence using the appropriate computer command.

A3.1.1.3 At the end of the automated warm-up sequence, the ramp-up and total warm-up times will be indicated on the computer monitor. Typical values for these times are 1300 s to 1800 s for ramp-up time and 1500 s to 2300 s for total warm-up time. Significant increases in the average ramp-up time (more than 5 %) or total warm-up time (more than 10 %) are indicative of a potential malfunction of the heating elements of the combustion chamber. For diagnostic procedures, refer to the instructions provided by the manufacturer.

A3.1.1.4 Open the valve at the source of each compressed gas and adjust the individual pressure regulators as needed to provide the specification pressures.

A3.1.1.5 Perform at least one preliminary ignition delay determination for a typical diesel fuel oil sample or heptane following the procedure described in 12.2. Check and adjust all operating conditions so that the combustion analyzer complies with the specification values and is ready for fit-for-use qualification testing. Discard the results of all preliminary ignition delay determinations.

A3.2 Fuel Injection System Procedure

A3.2.1 *General*—The sample fuel reservoir is illustrated in Fig. A2.2, Fuel Reservoir Schematic. The floating plunger is inserted between the pressurizing nitrogen and the fuel in the reservoir when a fuel specimen is to be tested. The floating plunger is omitted from the assembly during the sequences involving flushing of fuel when the pressurizing nitrogen is in direct contact with the fuel specimen. One flushing function involves forcing a portion of specimen fuel through the fuel injection pump and injector nozzle passages to ensure that they are full of fuel and free of any trapped air. A second flushing function is utilized to force all specimen fuel out of the

injection pump and injector nozzle passages after the completion of a test determination. Details of these functions are as follows:

A3.2.2 Flushing, filling, and purging the fuel injection system and discharging the sample post test.

A3.2.2.1 *Flushing the Fuel Injection System*:

(1) Fill the fuel sample reservoir with a volume of test specimen that is at least equivalent to the volume of the standard fuel sample reservoir (see A2.3.1) taking care to wet the walls of the reservoir during filling.

(2) The standard fuel sample reservoir as described in A2.3.1 and as shown in Fig. A2.2 does not have a check valve.

(3) If the fuel sample reservoir is larger than the standard fuel sample reservoir, and it has a check valve, shake the reservoir by hand for at least 5 s.

(4) If the fuel sample reservoir does not have a check valve, completely fill the reservoir with test specimen.

NOTE A3.1—All fuel sample reservoirs with a volume larger than the standard fuel sample reservoir, that also have a check valve, allow removal of the filled or partially filled reservoir from both the instrument and a filling/cleaning station.

(5) If this part of the procedure is done with the fuel sample reservoir on the instrument, flush the entire contents of the reservoir through the fuel injection system. Then use the compressed nitrogen supply to blow a sufficient amount of nitrogen through the fuel injection pump and injector body bleed valves to remove residual test specimen from the fuel injection system. Refer to the manufacturer's instructions for the details of the procedure.

(6) If the fuel sample reservoir has a check valve, it may be filled in a well ventilated location using a filling/cleaning station remote from the instrument. If this is done, connect the reservoir to the filling/cleaning station and fill it as directed in A3.2.2.1(1). Flush a small volume of the test specimen through the filling/cleaning station and refill the reservoir so that it again contains a volume of test specimen at least equivalent to the volume of a standard fuel sample reservoir. Remove the fuel sample reservoir from the loading station and install it onto the instrument. Flush the entire contents of the fuel sample

reservoir through the fuel injection system. Then use the compressed nitrogen supply to blow a sufficient amount of nitrogen through the fuel injection pump and injector body bleed valves to remove residual test specimen from the fuel injection system. Refer to the instructions provided by the manufacturer for the details of this flushing procedure.

A3.2.2.2 Filling and Purging the Fuel Injection System:

(1) Fill the fuel sample reservoir with another volume of test specimen that is at least equivalent to the volume of the standard fuel sample reservoir. Purge any air from the fuel injection system using this volume of test specimen.

(2) If the filling and purging procedure is done with the fuel sample reservoir on the instrument, fill the reservoir as in A3.2.2.1(1). Pressurize the fuel injection system with compressed nitrogen to force the test specimen through the system and purge the system of air. See manufacturer's instructions for details of this procedure.

(3) If the fuel sample reservoir has a check valve, it may be filled in a well ventilated location remote from the instrument. Fill the fuel sample reservoir by installing it on a filling/cleaning station and filling it as in A3.2.2.1(1). Then install the filled reservoir onto the instrument. Pressurize the fuel injection system with compressed nitrogen to force the test specimen through the system and purge the system of air. Refer to the instructions provided by the manufacturer for the details of this filling and purging procedure.

(4) The fuel system is now ready for the measurement procedure.

A3.2.3 Discharging Unused Specimen and Cleaning Fuel System:

A3.2.3.1 Discharge any unused specimen from the fuel sample reservoir, and clean the fuel injection system.

(1) If the fuel sample reservoir does not have a check valve, blow a sufficient amount of nitrogen from the compressed nitrogen system to remove unused test specimen from the reservoir and fuel injection system. Refer to manufacturer's instructions for the details of this procedure.

(2) If the fuel sample reservoir has a check valve, remove the reservoir from the instrument and connect it to the filling/cleaning station. Use compressed nitrogen to flush all residual test specimen from the reservoir. Refer to the manufacturer's instructions for the details of this procedure.

(3) Blow a sufficient amount of nitrogen from the compressed nitrogen system, using the fuel system flushing adaptor, through the fuel injection system to remove unused test specimen from the system. Refer to manufacturer's instructions for the details of this procedure.

(4) The fuel system is now prepared for the next test method sequence, which includes flushing and purging the fuel injection system prior to testing. (See A3.2.2.)

A3.2.4 Discharging Unused Specimen and Cleaning Fuel System, after Fuel Samples Containing 2EHN Cetane Improver at Either Unknown Concentrations or Concentrations Greater than 2000 ppm Have Just Been Tested (No Hardware Modifications Required):

A3.2.4.1 If the test specimen contains 2-ethyl hexylnitrate, commonly called cetane improver or 2EHN, at a concentration

greater than 2000 ppm the cleaning procedure above may not be sufficient. Discharging unused sample and cleaning the reservoir and fuel injection system after these samples includes use of either toluene or n-heptane solvent.

A3.2.4.2 Discharge any unused specimen from the fuel sample reservoir and fuel system (see A3.2.3.1(1) or A3.2.3.1(2)).

A3.2.4.3 If the fuel sample reservoir does not have a check valve, completely fill the reservoir with toluene or heptane. Slowly flush the entire contents of the fuel sample reservoir through the fuel injection system, taking a minimum of 2 min to complete the flushing. Using the compressed nitrogen supply, blow a sufficient amount of nitrogen through the reservoir and fuel injection system to remove residual toluene or heptane from the system. Refer to the instructions provided by the manufacturer for the details of this discharging procedure.

A3.2.4.4 If the fuel sample reservoir has a check valve, connect the reservoir to the filling/cleaning station. Fill the reservoir with a volume of toluene or heptane that is at least equivalent to the volume of the standard fuel reservoir. Flush a small amount of solvent through the filling/cleaning station, then add enough solvent to restore the original volume in the reservoir. Remove the fuel sample reservoir from the filling/cleaning station and shake it for 5 s to completely wet the walls of the reservoir. Connect the fuel sample reservoir to the instrument. Slowly flush the entire contents of the fuel sample reservoir through the fuel injection system, taking a minimum of 2 min to complete the flushing. Using the compressed nitrogen supply, blow a sufficient amount of nitrogen through the reservoir and fuel injection system to remove residual toluene or heptane from the system.

A3.2.4.5 The fuel injection system is now prepared for the next test method sequence, which includes flushing and purging the fuel injection system prior to testing. (See A3.2.)

A3.3 Pressure Sensor Assembly Cleaning Procedure

A3.3.1 (**Warning**—Avoid skin contact with the surfaces of the pressure sensor assembly and combustion chamber if the combustion analyzer is not at room temperature.)

A3.3.2 *General*—Performing periodic (twice per day) ignition delay determinations with heptane has been found to have the same effect as manually cleaning the pressure sensor assembly. Manual cleaning of the pressure sensor assembly is only required if the tip of the injector nozzle pintle breaks off, causing fuel to be sprayed directly onto pressure sensor's sensing surface.

A3.3.3 Cleaning Sensor Assembly:

A3.3.3.1 If a diesel fuel oil was used for the preliminary ignition delay determination of the operating period, perform an additional ignition delay determination with heptane before performing fit-for-use qualification testing.

A3.3.3.2 At the conclusion of each operating period, perform an ignition delay determination using heptane.

NOTE A3.2—If the combustion analyzer is to be left idle for more than 24 h before the start of the next operating period, flush the fuel injection system with a diesel fuel oil.

A3.4 Alternative Pressure Sensor Assembly Cleaning Procedure

A3.4.1 Check that the valve at the source of each compressed gas is closed, decompress the combustion chamber using the appropriate computer command, and position the combustion analyzer power switch to OFF.

A3.4.2 Disconnect the pressure sensor signal cable, remove the combustion chamber pressure sensor from its housing, clean the sensing surface of the pressure sensor and the hole of the pressure sensor housing in accordance with the instructions of the manufacturer.

A3.4.3 Reinstall the pressure sensor in its housing.

A3.4.4 Wipe any oily deposits from the sensor signal cable and connector and connect the cable to the pressure sensor.

A3.4.5 Position the combustion analyzer power switch to ON.

A3.4.6 Warm-up the combustion analyzer.

A3.5 Combustion Chamber Sealing Integrity Check Procedure

A3.5.1 Using the appropriate computer command, start an automated sealing integrity check of the warmed-up combustion chamber. This procedure tests the effectiveness of the combustion chamber seals by pressurizing the chamber with a

standard charge of compressed air. The pressure variation inside the chamber is monitored for a period of 20. s. The rate of decrease of pressure is displayed on the computer monitor.

A3.5.2 The operator is responsible to check that the displayed rate of decrease of pressure is less than the specified 3.5 kPa/s maximum limit.

A3.5.3 If the rate of decrease of pressure exceeds the limit, inadequate sealing is confirmed and diagnostic procedures to determine and remedy the problem are required before performing tests. Refer to the instructions provided by the manufacturer.

A3.6 Combustion Analyzer Shut Down Procedure

A3.6.1 Check that all specimen has been discharged from the fuel injection system and the fuel reservoir and associated components are clean.

A3.6.2 Close the valve at the source of each compressed gas.

A3.6.3 Open the appropriate bleed valves to decompress the piping between the compressed gas regulators and combustion analyzer. Close all bleed valves after decompressing the piping.

A3.6.4 Position the combustion analyzer power switch to OFF.

NOTE A3.3—Electric power for the circulating coolant system will remain on for 3 h after the combustion analyzer is shut down.

A4. SUPPLEMENTAL PROCEDURE INFORMATION

A4.1 Test Sequence

A4.1.1 *General*—An automated test run consists of 15 preliminary (pre-test injections) + 32 subsequent (test injections) combustion cycles. A combustion cycle involves: (1) charging the chamber to the test pressure, (2) injecting a small volume of fuel sample into the combustion chamber, and (3) releasing of the combustion gases. During the combustion cycle, the injector nozzle needle motion sensor measures the motion of the injector nozzle needle and the combustion chamber pressure sensor measures the charge air pressure.

A4.1.2 A simplified example of the output of the nozzle needle motion sensor and the combustion chamber pressure sensor recorded for a single combustion cycle during a test sequence is shown in [Fig. A4.1](#).

A4.1.3 The ignition delays of the 32 test injections are averaged to produce the analytical ID result.

A4.1.4 During each of the 32 test injections the following parameters are recorded:

ID	Parameters
DCN	
	Charge air pressure (<i>P2</i>)
	Injection actuator air pressure (<i>P3</i>)
	Charge air temperature (<i>T4</i>)
	Combustion chamber pressure sensor temperature (<i>T3</i>)
	Injector nozzle coolant passage temperature (<i>T6</i>)
	Coolant return temperature (<i>T7</i>)
	Fuel injection pump temperature (<i>T2</i>)

A4.1.5 The individual measured values of the above parameter for each of the 32 combustion cycles as well as their average, minimum and maximum are automatically printed on a test report at the end of each test (see [Appendix X1](#)).

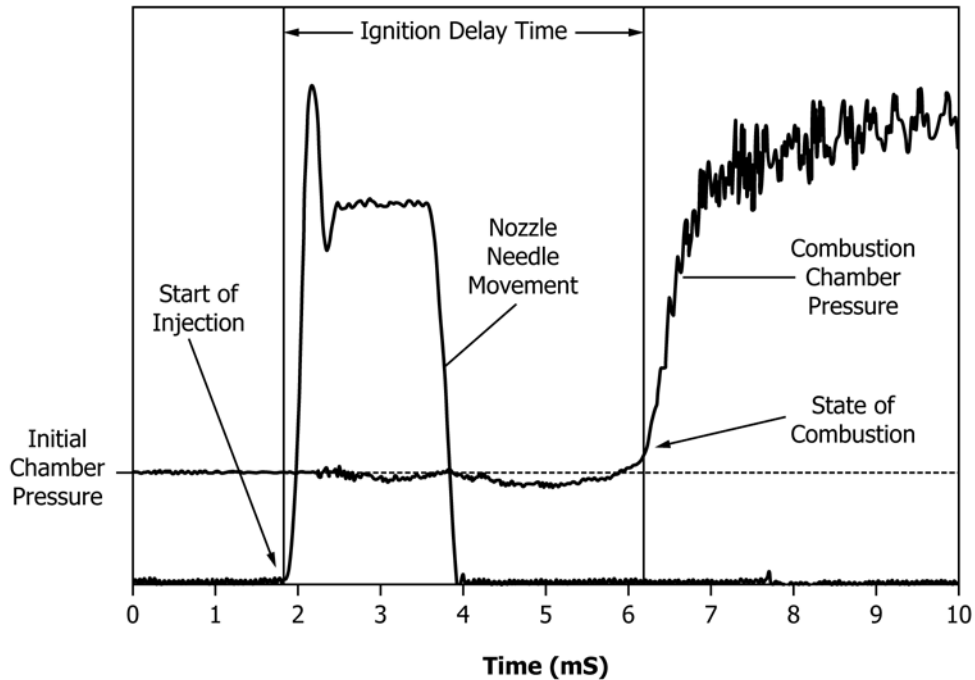

FIG. A4.1 Signals of Motion Sensor and Combustion Chamber Pressure Sensor During a Single Combustion Cycle

A5. DERIVATION AND MAINTENANCE OF DCN EQUATION

A5.1 Derived cetane number (DCN) is defined as a number calculated using a conversion equation to determine a cetane number (see 3.2.5).

A5.2 This equation has been derived using the 2004 ILS data set and initially validated using the 2002 ILS data set and the 2004 IP and NEG exchange scheme fuels. The derivation is described in RR:D02-1602.¹²

A5.3 The conversion equation (Eq 1) appears in Section 13. The ongoing validation of the DCN equation shall be moni-

tored and evaluated through the monthly NEG and IP fuel exchange programs. The validation data shall be reviewed by Subcommittee D02.01 through the application of Practice D6708 with a frequency of at least every three years. As a result of the review, Subcommittee D02.01 may make the decision to, if necessary, modify the existing equation or develop a new one. As part of this review, the sample types will be examined, and if certain types are underrepresented, further steps may be taken to evaluate how they perform.

APPENDIXES

(Nonmandatory Information)

X1. EXAMPLE OF TEST OUTPUT

IQT™ Results - Run Details

Run ID: 1043
 Fuel ID: Test Fuel 1234-567
 ISS version: X.XX, rev. XX
 Test Method: ASTM D6890-DD

Date & Time: XX/YY/20ZZ 3:44:25 PM
 Operator: J.D.
 Setpoint: 566.0
 S/W License Code: 000013-UA5D6A-423ASR-...

	Inj. #	ID	DCN	Charge P.	Inj. P.	Test T.	Trans T.	Nozzle T.	Coolant T.	Air B. T.	Pump T.
	1	4.034	50.72	2.138	1.205	543.1	124.8	49.4	42.0	572.6	35.1
	2	4.039	50.66	2.138	1.205	543.1	125.1	48.9	41.9	572.0	35.3
	3	4.070	50.31	2.138	1.205	542.6	125.1	49.1	42.0	572.3	35.1
	4	3.981	51.33	2.138	1.205	543.0	125.3	48.9	42.0	572.6	35.6
	5	4.051	50.52	2.138	1.206	543.0	125.4	49.2	42.1	571.7	35.2
	6	4.014	50.95	2.138	1.206	542.6	125.5	49.2	42.0	572.9	35.0
	7	3.965	51.52	2.139	1.206	542.4	125.8	49.0	41.6	572.3	35.3
	8	3.928	51.96	2.139	1.206	542.5	125.5	49.0	42.0	572.0	35.2
	9	3.928	51.97	2.138	1.206	542.9	125.6	49.1	42.1	572.1	34.8
	10	4.064	50.38	2.138	1.206	543.2	125.6	49.0	41.6	571.9	35.6
	11	3.910	52.19	2.138	1.206	543.0	125.6	49.1	42.0	572.8	35.3
	12	3.941	51.81	2.138	1.206	543.3	125.3	49.2	42.0	572.0	35.3
	13	3.954	51.66	2.138	1.206	543.0	125.5	49.3	42.1	571.5	35.7
	14	4.032	50.74	2.138	1.206	542.8	125.6	49.0	42.0	572.4	35.2
	15	3.921	52.04	2.139	1.206	543.0	125.6	48.9	42.0	571.8	35.4
	16	3.972	51.44	2.138	1.207	542.5	125.7	49.1	42.0	572.4	35.6
	17	4.056	50.47	2.138	1.206	543.2	125.7	49.0	42.0	572.4	35.1
Injection	18	3.961	51.57	2.138	1.207	543.5	125.7	49.1	42.0	572.8	35.0
Actuator Air	19	4.051	50.52	2.137	1.207	543.3	125.8	48.9	42.0	571.9	35.4
Pressure (P3)	20	4.127	49.68	2.138	1.206	542.3	125.8	49.1	42.0	572.5	35.3
	21	3.946	51.75	2.138	1.207	542.4	125.9	49.0	42.0	572.6	35.2
Charge Air	22	3.966	51.51	2.139	1.207	542.8	126.1	48.9	42.0	571.3	35.4
Pressure (P2)	23	3.924	52.02	2.138	1.207	542.9	126.0	49.2	42.0	572.9	35.4
	24	4.069	50.32	2.139	1.207	543.0	126.1	49.3	42.0	572.0	35.2
Derived Cetane	25	3.927	51.98	2.138	1.207	542.0	126.0	49.0	41.9	572.0	35.3
Number (DCN)	26	4.044	50.60	2.140	1.207	542.7	126.0	49.2	42.0	572.1	35.1
	27	3.959	51.59	2.138	1.207	543.1	126.0	49.0	42.0	572.8	35.2
Ignition Delay	28	4.021	50.86	2.138	1.207	542.9	125.7	48.9	42.2	572.3	35.2
(ID) Result	29	4.036	50.70	2.138	1.208	543.3	125.9	49.2	42.0	572.1	35.1
	30	3.984	51.29	2.139	1.208	543.0	126.0	49.3	41.9	572.4	35.2
	31	4.015	50.94	2.140	1.207	542.7	125.9	49.4	42.0	571.9	35.3
	32	3.950	51.70	2.140	1.208	542.8	125.9	49.0	41.9	572.1	35.2
Avg.:		3.995	51.17	2.138	1.207	542.9	125.7	49.1	42.0	572.2	35.3
Min.:		3.910	49.68	2.137	1.205	542.0	124.8	48.9	41.6	571.3	34.8
Max.:		4.127	52.19	2.140	1.208	543.5	126.1	49.4	42.2	572.9	35.7
Range:		0.217	2.51	0.003	0.003	1.5	1.3	0.5	0.7	1.5	0.9
Std. Dev.:		0.057	0.66	0.001	0.001	0.3	0.3	0.1	0.1	0.4	0.2

Charge Air Temperature (T4)	→	542.9
Minimum Charge Air Temperature (T4 _{min})	→	542.0
Maximum Charge Air Temperature (T4 _{max})	→	543.5
T4 _{max} - T4 _{min}	→	1.5
Combustion Chamber Pressure Sensor Temperature (T3)	→	125.7
Minimum Combustion Chamber Pressure Sensor Temperature (T3 _{min})	→	124.8
Maximum Combustion Chamber Pressure Sensor Temperature (T3 _{max})	→	126.1
T3 _{max} - T3 _{min}	→	1.3
Coolant Return Temperature (T7)	→	42.0
Fuel Injection Pump Temperature (T2)	→	49.1
Maximum Injector Nozzle Coolant Passage Temperature (T6 _{max})	→	49.4
Minimum Injector Nozzle Coolant Passage Temperature (T6 _{min})	→	48.9
Injector Nozzle Coolant Passage Temperature (T6)	→	49.1

FIG. X1.1 Example of Test Output

X2. CORRELATION EQUATION

X2.1 This is a conversion equation for derived cetane number outside the ignition delay range 3.1 ms to 6.5 ms:

$$DCN = 83.99(ID - 1.512)^{(-0.658)} + 3.547 \quad (X2.1)$$

There is no precision for this equation for derived cetane number outside the range of 3.3 ms to 6.4 ms.

NOTE X2.1—The equation was derived from a correlation test program, comprising ASTM National Exchange Group (NEG) check fuels, heptamethylnonane, cetane and an in-house check fuel.¹⁵

¹⁵ Supporting data have been filed at ASTM International Headquarters and may be obtained by requesting Research Report RR:D02-1531.

SUMMARY OF CHANGES

Subcommittee D02.01 has identified the location of selected changes to this standard since the last issue (D6890–15b) that may impact the use of this standard. (Approved April 1, 2016.)

- | | |
|--|--|
| (1) Revised 1.1; revised Section 3, Terminology, and Section 15, Precision and Bias. | (2) Added new 1.4; added Practice E29 to Referenced Documents. |
|--|--|

Subcommittee D02.01 has identified the location of selected changes to this standard since the last issue (D6890–15a) that may impact the use of this standard. (Approved Dec. 1, 2015.)

- (1) Revised 5.2.

Subcommittee D02.01 has identified the location of selected changes to this standard since the last issue (D6890–15) that may impact the use of this standard. (Approved Oct. 1, 2015.)

- (1) Revised subsection 1.1 and 1.2 in Scope.

Subcommittee D02.01 has identified the location of selected changes to this standard since the last issue (D6890–13b^{ε1}) that may impact the use of this standard. (Approved July 1, 2015.)

- | | |
|--|---|
| (1) Added clarifying language to 11.1, 12.2.6, A3.5.2, and A3.5.3. | (2) Decimal points were added to values in 7.3.3, 10.4.2, 10.4.4, 10.4.5, 10.4.10, 11.3.1.4, A3.5.1, and Table 2. |
|--|---|

ASTM International takes no position respecting the validity of any patent rights asserted in connection with any item mentioned in this standard. Users of this standard are expressly advised that determination of the validity of any such patent rights, and the risk of infringement of such rights, are entirely their own responsibility.

This standard is subject to revision at any time by the responsible technical committee and must be reviewed every five years and if not revised, either reapproved or withdrawn. Your comments are invited either for revision of this standard or for additional standards and should be addressed to ASTM International Headquarters. Your comments will receive careful consideration at a meeting of the responsible technical committee, which you may attend. If you feel that your comments have not received a fair hearing you should make your views known to the ASTM Committee on Standards, at the address shown below.

This standard is copyrighted by ASTM International, 100 Barr Harbor Drive, PO Box C700, West Conshohocken, PA 19428-2959, United States. Individual reprints (single or multiple copies) of this standard may be obtained by contacting ASTM at the above address or at 610-832-9585 (phone), 610-832-9555 (fax), or service@astm.org (e-mail); or through the ASTM website (www.astm.org). Permission rights to photocopy the standard may also be secured from the Copyright Clearance Center, 222 Rosewood Drive, Danvers, MA 01923, Tel: (978) 646-2600; http://www.copyright.com/