



# Standard Guide for Performance Evaluation of Hydraulic Fluids for Piston Pumps<sup>1</sup>

This standard is issued under the fixed designation D6813; the number immediately following the designation indicates the year of original adoption or, in the case of revision, the year of last revision. A number in parentheses indicates the year of last reapproval. A superscript epsilon ( $\epsilon$ ) indicates an editorial change since the last revision or reapproval.

## 1. Scope

1.1 This guide covers the establishment of test protocols and methodologies for determining the suitability of fluids for use in fluid power systems that incorporate axial or radial piston pumps. The suitability of all fluid types to meet specific levels of performance in piston pumps is addressed. These fluids include, but are not limited to formulations based on mineral, synthetic or vegetable oil base stocks. The finished fluids may be in the form of straight oils, soluble oils or invert emulsions.

1.2 The test protocols and methodologies described in this guide have been selected for their ability to distinguish between highly acceptable, acceptable and unacceptable fluid performance in piston pumps. They take into account the broad range of operating conditions piston pumps are subjected to, as well as the common variations in design and materials of construction among pump manufacturers.

1.3 This guide is intended to complement proprietary test protocols and methodologies employed by some piston pump manufacturers. The test protocols and methodologies within this guide may help pump manufacturers, fluid formulators and end users accurately screen potential fluids for specific performance characteristics. The results of this screening may be sufficient in certain instances for pump manufacturers to forego requirements for additional fluid performance tests.

1.4 *This standard does not purport to address all of the safety concerns, if any, associated with its use. It is the responsibility of the user of this standard to establish appropriate safety and health practices and determine the applicability of regulatory requirements prior to use.*

## 2. Referenced Documents

### 2.1 ASTM Standards:<sup>2</sup>

<sup>1</sup> This guide is under the jurisdiction of ASTM Committee D02 on Petroleum Products, Liquid Fuels, and Lubricants and is the direct responsibility of Subcommittee D02.N0.07 on Lubricating Properties.

Current edition approved May 1, 2013. Published August 2013. Originally approved in 2002. Last previous edition approved in 2007 as D6813 – 02a (2007). DOI: 10.1520/D6813-02AR13.

<sup>2</sup> For referenced ASTM standards, visit the ASTM website, [www.astm.org](http://www.astm.org), or contact ASTM Customer Service at [service@astm.org](mailto:service@astm.org). For *Annual Book of ASTM Standards* volume information, refer to the standard's Document Summary page on the ASTM website.

- D92 Test Method for Flash and Fire Points by Cleveland Open Cup Tester
- D93 Test Methods for Flash Point by Pensky-Martens Closed Cup Tester
- D95 Test Method for Water in Petroleum Products and Bituminous Materials by Distillation
- D97 Test Method for Pour Point of Petroleum Products
- D130 Test Method for Corrosiveness to Copper from Petroleum Products by Copper Strip Test
- D445 Test Method for Kinematic Viscosity of Transparent and Opaque Liquids (and Calculation of Dynamic Viscosity)
- D482 Test Method for Ash from Petroleum Products
- D611 Test Methods for Aniline Point and Mixed Aniline Point of Petroleum Products and Hydrocarbon Solvents
- D664 Test Method for Acid Number of Petroleum Products by Potentiometric Titration
- D665 Test Method for Rust-Preventing Characteristics of Inhibited Mineral Oil in the Presence of Water
- D874 Test Method for Sulfated Ash from Lubricating Oils and Additives
- D877 Test Method for Dielectric Breakdown Voltage of Insulating Liquids Using Disk Electrodes
- D892 Test Method for Foaming Characteristics of Lubricating Oils
- D943 Test Method for Oxidation Characteristics of Inhibited Mineral Oils
- D974 Test Method for Acid and Base Number by Color-Indicator Titration
- D1121 Test Method for Reserve Alkalinity of Engine Coolants and Antirusts
- D1123 Test Methods for Water in Engine Coolant Concentrate by the Karl Fischer Reagent Method
- D1169 Test Method for Specific Resistance (Resistivity) of Electrical Insulating Liquids
- D1298 Test Method for Density, Relative Density, or API Gravity of Crude Petroleum and Liquid Petroleum Products by Hydrometer Method
- D1401 Test Method for Water Separability of Petroleum Oils and Synthetic Fluids
- D1500 Test Method for ASTM Color of Petroleum Products (ASTM Color Scale)

**D1533** Test Method for Water in Insulating Liquids by Coulometric Karl Fischer Titration  
**D2070** Test Method for Thermal Stability of Hydraulic Oils  
**D2270** Practice for Calculating Viscosity Index from Kinematic Viscosity at 40 and 100°C  
**D2272** Test Method for Oxidation Stability of Steam Turbine Oils by Rotating Pressure Vessel  
**D2273** Test Method for Trace Sediment in Lubricating Oils  
**D2422** Classification of Industrial Fluid Lubricants by Viscosity System  
**D2619** Test Method for Hydrolytic Stability of Hydraulic Fluids (Beverage Bottle Method)  
**D2624** Test Methods for Electrical Conductivity of Aviation and Distillate Fuels  
**D2717** Test Method for Thermal Conductivity of Liquids  
**D2766** Test Method for Specific Heat of Liquids and Solids  
**D2783** Test Method for Measurement of Extreme-Pressure Properties of Lubricating Fluids (Four-Ball Method)  
**D2879** Test Method for Vapor Pressure-Temperature Relationship and Initial Decomposition Temperature of Liquids by Isotenoscope  
**D2882** Test Method for Indicating Wear Characteristics of Petroleum and Non-Petroleum Hydraulic Fluids in Constant Volume Vane Pump (Withdrawn 2003)<sup>3</sup>  
**D2983** Test Method for Low-Temperature Viscosity of Lubricants Measured by Brookfield Viscometer  
**D3427** Test Method for Air Release Properties of Petroleum Oils  
**D3487** Specification for Mineral Insulating Oil Used in Electrical Apparatus  
**D4052** Test Method for Density, Relative Density, and API Gravity of Liquids by Digital Density Meter  
**D4172** Test Method for Wear Preventive Characteristics of Lubricating Fluid (Four-Ball Method)  
**D4293** Specification for Phosphate Ester Based Fluids for Turbine Lubrication  
**D4308** Test Method for Electrical Conductivity of Liquid Hydrocarbons by Precision Meter  
**D4310** Test Method for Determination of Sludging and Corrosion Tendencies of Inhibited Mineral Oils  
**D4652** Specification for Silicone Fluid Used for Electrical Insulation  
**D5182** Test Method for Evaluating the Scuffing Load Capacity of Oils (FZG Visual Method)  
**D5185** Test Method for Multielement Determination of Used and Unused Lubricating Oils and Base Oils by Inductively Coupled Plasma Atomic Emission Spectrometry (ICP-AES)  
**D5222** Specification for High Fire-Point Mineral Electrical Insulating Oils  
**D5534** Test Method for Vapor-Phase Rust-Preventing Characteristics of Hydraulic Fluids  
**D5621** Test Method for Sonic Shear Stability of Hydraulic Fluids  
**D6006** Guide for Assessing Biodegradability of Hydraulic Fluids

**D6046** Classification of Hydraulic Fluids for Environmental Impact  
**D6080** Practice for Defining the Viscosity Characteristics of Hydraulic Fluids  
**D6158** Specification for Mineral Hydraulic Oils  
**D6304** Test Method for Determination of Water in Petroleum Products, Lubricating Oils, and Additives by Coulometric Karl Fischer Titration  
**D6376** Test Method for Determination of Trace Metals in Petroleum Coke by Wavelength Dispersive X-ray Fluorescence Spectroscopy  
**D6546** Test Methods for and Suggested Limits for Determining Compatibility of Elastomer Seals for Industrial Hydraulic Fluid Applications  
**D6547** Test Method for Corrosiveness of Lubricating Fluid to Bimetallic Couple  
**D6595** Test Method for Determination of Wear Metals and Contaminants in Used Lubricating Oils or Used Hydraulic Fluids by Rotating Disc Electrode Atomic Emission Spectrometry  
**E70** Test Method for pH of Aqueous Solutions With the Glass Electrode  
**E203** Test Method for Water Using Volumetric Karl Fischer Titration  
**E659** Test Method for Autoignition Temperature of Liquid Chemicals  
**F312** Test Methods for Microscopical Sizing and Counting Particles from Aerospace Fluids on Membrane Filters

#### 2.2 AFNOR Standards:<sup>4</sup>

**AFNOR NF E48-690** Hydraulic Fluid Power. Fluids. Measurement of Filterability of Mineral Oils  
**AFNOR NF E48-691** Hydraulic Fluid Power. Fluids. Measurement of Filterability of Minerals Oils in the Presence of Water  
**AFNOR NF E48-692** Hydraulic Fluid Power. Fluids. Measurement of Filterability of HFC and HFD Class Fire Resistant Fluids

#### 2.3 ANSI (NFPA) Standards:<sup>5</sup>

**ANSI(NFPA) Standard T2.13.7R1-1996** Hydraulic Fluid Power—Petroleum Fluids—Prediction of Bulk Moduli  
**ANSI/Standard NFPA/JIC T2.24.1-1990** Hydraulic Fluid Power—Systems Standard for Stationary Industrial Machinery  
**ANSI(NFPA) Standard T3.9.20-1992** Hydraulic Fluid Power—Pumps—Method of Testing and Presenting Basic Performance Data for Pressure Compensated Pumps  
**ANSI(NFPA) Standard T3.9.33-1997** Hydraulic Fluid Power—Pumps—Method of Testing and Presenting Basic Performance Data for Load Sensing Pumps  
**ANSI(NFPA) Standard T3.16.2-R1-1997** Hydraulic Fluid Power—Design for Nonintegral Industrial Reservoirs

<sup>4</sup> Available from AFNOR, Administration des Ventes, 11, avenue Francis de Pressensi, 93571 Saint-Denis La Plaine Cedex.

<sup>5</sup> Available from American National Standards Institute (ANSI), 25 W. 43rd St., 4th Floor, New York, NY 10036.

<sup>3</sup> The last approved version of this historical standard is referenced on [www.astm.org](http://www.astm.org).

#### 2.4 CETOP Standard:

**CETOP RP 67H** Antiwear Vane Pump Test for Hydraulic Fluids<sup>6</sup>

#### 2.5 DIN Standards:<sup>7</sup>

**DIN 51348** Testing of Fire Resistant Governor Fluids; Determination of Hydrolytic Stability

**DIN 51373** Testing of Fire Resistant Governor Fluids; Determination of Oxidative Stability Including Evaluation of Catalyst Plates

**DIN 51389/2** Determination of Lubricants; Mechanical Testing of Hydraulic Fluids in the Vane-Cell-Pump; Method A for Anhydrous Hydraulic Fluids

**DIN 51389/3** Determination of Lubricants; Mechanical Testing of Hydraulic Fluids in the Vane-Cell-Pump—Part 3: Method B for Aqueous Not Easily Inflammable Hydraulic Fluids

**DIN 51515, Part 1** Lubricants and Governor Fluids for Steam Turbines; L-TD Lubricating Oils and Governor Oils; Minimum Requirements

**DIN 51554, Part 3** Testing of Mineral Oils; Test of Susceptibility to Aging According to Baader; Testing at 95°C

#### 2.6 Energy Institute Standard:<sup>8</sup>

**IP 281** Determination of Anti-Wear Properties of Hydraulic Fluids—Vane Pump Method

#### 2.7 ISO Standards:<sup>9</sup>

**ISO 4021** Hydraulic Fluid Power—Particulate Contamination Analysis—Extraction of Fluid Samples From Lines of an Operating System

**ISO 4402** Hydraulic Fluid Power—Calibration of Automatic-Count Instruments for Particles Suspended in Liquids—Method Using Classified AC Fine Test Dust Contaminant

**ISO 4404** Petroleum and Related Products—Determination of the Corrosion Resistance of Water-Containing Fire-Resistant Fluids for Hydraulic Systems

**ISO 4406** Hydraulic Fluid Power—Fluids—Method for Coding The Level of Contamination by Solid Particles

**ISO 4407** Hydraulic Fluid Power—Fluid Contamination—Determination of Particulate Contamination by the Counting Method Using a Microscope

**ISO 5884** Aerospace—Fluid Systems and Components—Methods for System Sampling and Measuring the Solid Particle Contamination of Hydraulic Fluids

**ISO 6073** Petroleum Products—Prediction of the Bulk Moduli of Petroleum Fluids Used in Hydraulic Power Systems

**ISO 6743/4 Part 4: Family H (Hydraulic Systems), Lubricants, Industrial Oils and Related Products (Class L) : Classification Part 4: Family H (Hydraulic Systems)**

**ISO 11171** Hydraulic Fluid Power—Calibration of Automatic Particle Counters for Liquids

**ISO 12922** Lubricants, Industrial Oils and Related Products (Class L)—Family H (Hydraulic Systems)—Specifications for Categories HFAE, HFAS, HFB, HFC, HFDR and HFDU

**ISO 13357-2 Part 2: Petroleum Products—Determination of the Filterability of Lubricating Oils—Part 2: Procedure for Dry Oils**

**ISO 14935** Petroleum and Related Products—Determination of Wick Flame Persistence of Fire-Resistant Fluids

**ISO 15029** Petroleum and Related Products—Determination of Spray Ignition Characteristics of Fire-Resistant Fluids—Part I: Spray Flame Persistence—Hollow Cone Nozzle Method

#### 2.8 LUX Standard:<sup>10</sup>

**LUX 5.9** Determination of the Corrosion Inhibiting Properties of Fluids, Requirements for Tests Applicable to Fire-Resistant Fluids Used for Power Transmission and Control (Hydrostatic and Hydrokinetic), April, 1994

#### 2.9 SAE Standards:<sup>11</sup>

**SAE J745** Surface Vehicle Recommended Practice, Hydraulic Power Pump Test Procedure

**SAE J1276 MAR86** Standardized Fluid for Hydraulic Component Tests

### 3. Terminology

#### 3.1 Definitions of Terms Specific to This Standard:

3.1.1 *abrasive wear*—wear due to hard particles, including wear debris or fluid contaminants, or hard protuberances forced against and moving along a hard surface.

3.1.2 *axial piston pump*—in the axial piston pump, the pistons are positioned axially, parallel to the driveshaft, and their reciprocating motion is caused by an inclined swash plate as illustrated in Fig. 1.

3.1.3 *bent axis piston pump*—in the bent axis piston pump, the axis of the cylinder barrel is held at a fixed angle relative to the centerline of the driveshaft as illustrated in Fig. 2.

3.1.4 *biodegradable*—capable of undergoing decomposition into carbon dioxide, methane, water, inorganic compounds, or biomass in which the predominant mechanism is the enzymatic action of microorganisms that can be measured by standardized tests, in a specific period of time, reflecting available disposal conditions.

3.1.5 *biomass*—any material, excluding fossil fuels, which is or was a living organism that can be used as a fuel. Peanut hulls, agricultural waste, corn and other grains, and sugar are all examples of biomass.

3.1.6 *case drainage*—leakage from around piston clearances and control valves to the case drain port in the pump housing which returns fluid to the reservoir.

<sup>10</sup> Available from European Safety and Health Commission for the Mining and Other Extractive Industries, Doc. No. 4746/10/91, EN, Luxembourg.

<sup>11</sup> Available from Society of Automotive Engineers (SAE), 400 Commonwealth Dr., Warrendale, PA 15096-0001.

<sup>6</sup> Per the CETOP website, this standard is no longer available for purchase and is officially withdrawn. Most CETOP technical documents have been replaced by ISO standards over the years (a cross-reference list is available from CETOP). This standard will be retained pending completion of work in CEN/TC19/WG28.

<sup>7</sup> Available from Beuth Verlag GmbH (DIN-- DIN Deutsches Institut für Normung e.V.), Burggrafenstrasse 6, 10787, Berlin, Germany.

<sup>8</sup> Available from Energy Institute, 61 New Cavendish St., London, WIG 7AR, U.K., <http://www.energyinst.org.uk>.

<sup>9</sup> Available from International Organization for Standardization (ISO), 1 rue de Varembé, Case postale 56, CH-1211, Geneva 20, Switzerland.

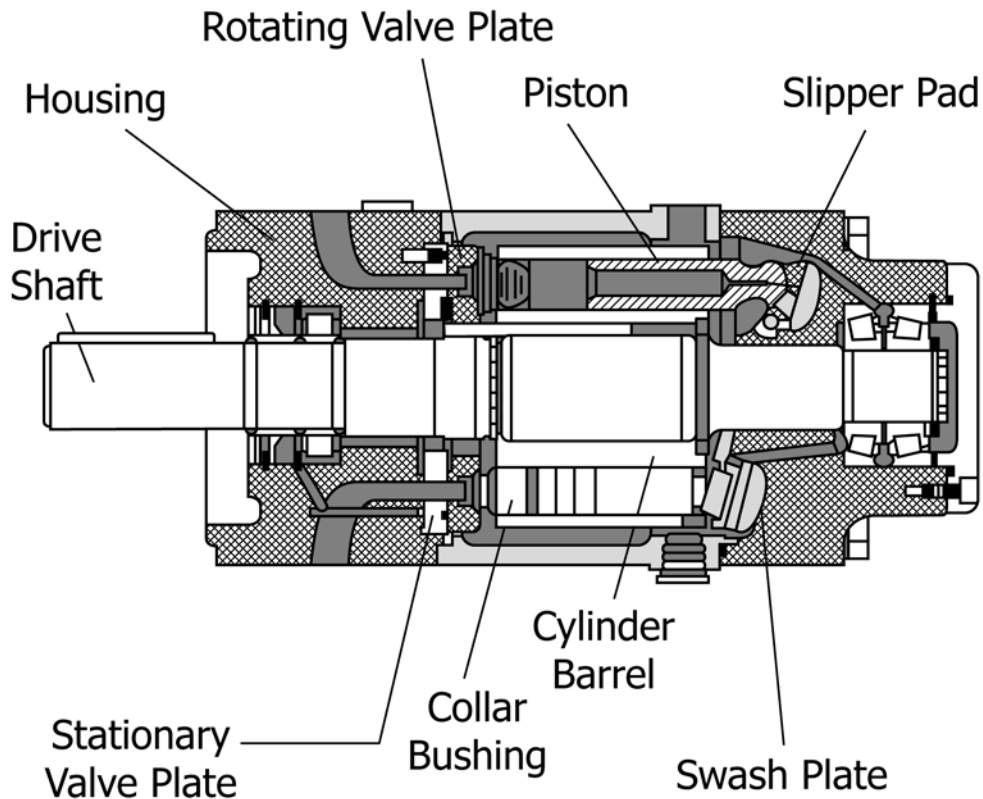

FIG. 1 Illustration of an Axial Piston Pump

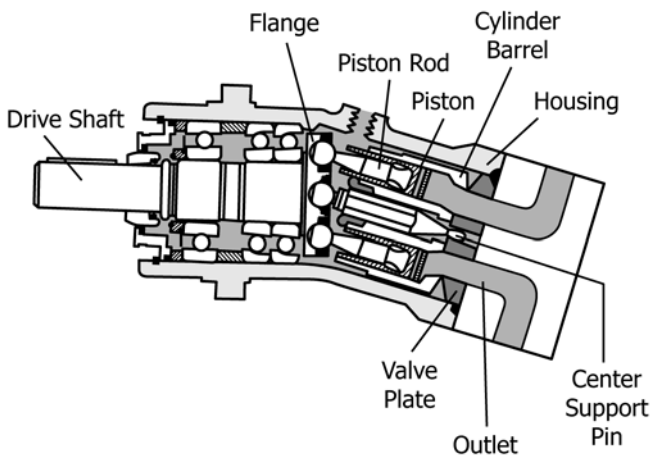

FIG. 2 Illustration of a Bent Axis Piston Pump

3.1.7 *cycled volume*—cycled volume testing subjects a hydraulic pump or component to repeated pulses of volume flow from a predetermined minimum to a maximum flow at a constant pressure.

3.1.8 *delivery*—the flow output per unit time expressed in litres per minute (L/min) or in gallons per minute (gal/min).

3.1.9 *displacement (geometrical)*—the volume of hydraulic fluid that is transported through the hydraulic pump during a single rotation of the pump shaft and is expressed in volume output per revolution ( $\text{cm}^3/\text{rev}$  or  $\text{in.}^3/\text{rev}$ ).

3.1.10 *face plate (valve plate, port plate, lens plate)*—the face plate, which is held at a fixed position, controls the timing of the inlet and outlet of the fluid flow, depending on the position of the cylinder barrel, during rotation of the pump.

3.1.11 *filterability*—a measure of the fluid’s ability to pass through filter media.

3.1.12 *fixed displacement*—the amount of flow cannot be varied per each shaft rotation although it can be varied by varying the rotational speed of the shaft.

3.1.13 *flow degradation*—flow degradation refers to the loss of flow through the hydraulic pump caused by lubrication wear, cavitation erosion, or contamination wear and is expressed as the ratio of flow rate delivered after the test to the flow rate delivered before the test.

3.1.14 *fluid residence time (turnover time)*—the average time that a given volume of fluid remains in the reservoir from the time of entry into the reservoir from the system until it enters the pump inlet is determined by the reservoir volume/flow rate.

3.1.15 *hydraulic power*—the output power of a hydraulic pump which is defined by:

$$W \text{ (Watt)} = \frac{\text{Delivery (L/min)} \times \text{Pressure (kPag)}}{60} \quad (1)$$

$$\text{hp (Horsepower)} = \frac{\text{Delivery (gal/min)} \times \text{Pressure (psig)}}{1714} \quad (2)$$

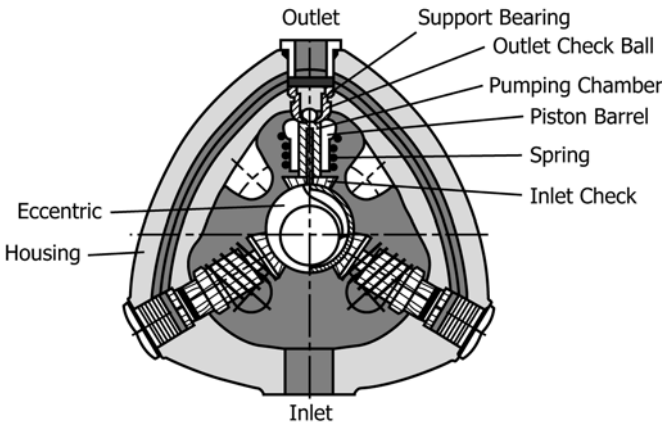

FIG. 3 Schematic Illustration of a Radial Piston Pump

3.1.16 *inlet pressure (minimum)*—the minimum inlet pressure, specified by the pump supplier, for each set of operating parameters.

3.1.17 *leakage flow*—this is related to the annular clearance between the piston and the cylinder; increased clearances due to erosion and wear results in a loss of volumetric efficiency (see 3.1.26).

3.1.18 *leakage pressure (case drain pressure)*—back-pressure that the case experiences during leakage which is determined by the size of the case drain port, hose, fluid viscosity, and the rate of leakage flow to the reservoir via the case drain.

3.1.19 *operating pressure*—the pressure at the discharge port of the hydraulic pump.

3.1.20 *pulsed (cycled) pressure*—pulsed pressure testing subjects a hydraulic pump or component to repeated pressure pulses (at a constant volume), often from close to zero (minimum load) to a predetermined maximum pressure, in order to evaluate fatigue life or moving part interaction problems and leakage.

3.1.21 *pump capacity (pump displacement)*—the actual pump displacement expressed in volume per revolution ( $\text{cm}^3/\text{rev}$ ).

3.1.22 *radial piston pump*—in the radial piston pump, the pistons are positioned radially, perpendicular to the driveshaft, and piston motion is caused by the use of a fixed cylinder and rotating cam plate as illustrated in Fig. 3, or a rotating block around a stationary cam can also be used.

3.1.23 *reservoir, hydraulic*—a container for the storage of a fluid used in a hydraulic system.

3.1.24 *shaft power*—the input power driving the hydraulic pump (often from an electric motor) which is defined by:

$$W \text{ (Watt)} = \frac{\text{Torque (N}\cdot\text{m)} \times \text{Speed (rpm)}}{9.549} \quad (3)$$

$$\text{hp (Horsepower)} = \frac{\text{Torque (lbf}\cdot\text{in.)} \times \text{Speed (rpm)}}{63\,025} \quad (4)$$

3.1.25 *swash plate (creep plate, wear plate, wobble plate)*—in a swash-plate (axial) piston pump, the shaft rotates the piston block, thus rotating the pistons, which are held

against the surface of a swash plate by springs and a retainer plate. For the piston pump to produce a flow, the swash plate must be held at some angle relative to the centerline of the shaft and the angle will force the pistons to move in and out of the piston or cylinder barrel of the pump as shown in Fig. 1.

3.1.26 *total efficiency*—hydraulic pumping efficiency, or total efficiency ( $E_T$ ), is a combination of two efficiencies, volumetric efficiency ( $E_v$ ) and mechanical efficiency ( $E_m$ ) and is determined from variable displacement.

$$E_v = \frac{\text{Actual Flow Output}}{\text{Theoretical Flow Output}} \quad (5)$$

$$E_m = \frac{\text{Theoretical Torque Input}}{\text{Actual Torque Output}} \quad (6)$$

$$E_T = E_v \times E_m \quad (7)$$

3.1.27 *variable displacement*—the amount of flow per each shaft revolution may be varied to limit the outlet flow to a preselected value.

#### 4. Significance and Use

4.1 Users of hydraulic equipment which includes piston pumps would like assurance that the fluids they use will allow their systems to operate safely with reasonable equipment life. This assurance is commonly provided by the fluid supplier in the form of results of standardized tests on the fluid, or demonstrated success in field use in similar systems, or both. This guide will help fluid developers and users develop testing protocols which demonstrate the suitability of a fluid for its intended use, including any required limitations on hydraulic system operating conditions.

4.2 The significance and use of each test method cited in this guide will depend upon the system in use and the purpose of the test method. Use the most recent editions of ASTM test methods.

#### 5. Fluid Classification

5.1 Mineral oil hydraulic fluids are classified in Specification D6158. Fire-resistant hydraulic fluids are classified in ISO 6743/4 and the specifications for these fluid classes are provided in ISO 12922.

##### 5.2 Mineral Oil Hydraulic Fluids:

5.2.1 *Type HH Hydraulic Oils*—Non-inhibited refined mineral oils for hydraulic systems that do not have specific requirements of oxidation stability, rust protection, or anti-wear properties. Type HH oils are usually intended for total loss systems or very light duty equipment.

5.2.2 *Type HL Hydraulic Oils*—Refined mineral oils with improved rust protection and oxidation stability for hydraulic systems where relatively high temperatures and long periods of operation time are expected, and where there is the possibility of water or humidity that could rust metal parts of the machinery. These oils are intended for use in systems where only full film lubrication is expected between the moving parts. Usually systems working at low pressures specify HL oils. Some high-pressure piston pumps can operate satisfactorily on these oils.

5.2.3 *Type HM Hydraulic Oils*—Oils of HL type with improved anti-wear properties, for general hydraulic systems,

especially for those working at high pressure and where the possibility of metal to metal contact exists. Type HM oils are usually specified for hydraulic systems with vane pumps, or when the system is intended to work at maximum pump capacity for long periods of time.

5.2.4 *Type HV Hydraulic Oils*—Oils of the HM type with improved viscosity/temperature properties, for general hydraulic systems where equipment is intended to operate over a wide range of ambient temperatures.

### 5.3 *Fire-Resistant Hydraulic Fluids:*

5.3.1 *Type HFA Hydraulic Fluids*—Fire-resistant hydraulic fluids that may be further classified as:

5.3.1.1 *Type HFAE Hydraulic Fluids*—Mineral oil-in-water emulsions containing less than 20 % by volume mineral oil.

5.3.1.2 *Type HFAS Hydraulic Fluids*—Mineral oil-free aqueous synthetic polymer-thickened solutions, often microemulsions, containing >80 % water. These fluids are suitable for use at low working pressures and temperatures varying from 5 to <55°C.

5.3.2 *Type HFB Hydraulic Fluids*—Water-in-mineral oil emulsions containing <60 % mineral oil, which are used as fire-resistant hydraulic fluids at operating temperatures of 5 to <55°C.

5.3.3 *Type HFC Hydraulic Fluids*—Thickened water-glycol fluids containing >35 % water which are suitable for use at operating temperatures of -20 to <60°C.

5.3.4 *Type HFD Hydraulic Fluids*—Anhydrous synthetic fire-resistant fluids used at operating temperatures of <120°C. Type HFD fluids are further subdivided into Types HFD-R and HFD-U. Type HFD-R fluids are based on phosphate esters and Type HFD-U fluids are based on polyol esters.

### 5.4 *Biodegradable Hydraulic Fluids:*

5.4.1 *Type HETG Hydraulic Fluids*—Typically, biodegradable, water-insoluble hydraulic fluids derived from vegetable oils. These fluids may be used at operating temperatures of -20 to <80°C.

5.4.2 *Type HEES Hydraulic Fluids*—Typically biodegradable fluids derived from synthetic esters, such as polyol ester and diesters, which may be used at operating temperatures of -35 to <90°C.

5.4.3 *Type HEPG Hydraulic Fluids*—Polyalkylene glycol derived fluids that may be water-soluble or insoluble with varying degrees of biodegradability and fire resistance. These fluids are suitable for use at operating temperatures of -30 to <90°C.

5.4.4 *Type HEPR Hydraulic Fluids*—Biodegradable fluids whose basestocks are derived from polyalphaolefin and related hydrocarbons.

5.4.5 *Other Biodegradable Fluids*—Paragraphs 5.4.1 – 5.4.4 describe HETG, HEES, HEPG, and HEPR fluids as biodegradable fluids. However, there are other types of biodegradable fluids not included in a listing. Fluid biodegradability is established by specific testing protocol. For example, some fire-resistant fluids of the HFC and HFD type are readily biodegradable as established by Guide D6006, but this is not reflected in the current ISO specifications. In this guide, reference to biodegradable fluids indicates that they pass

appropriate biodegradability standards, not necessarily their placement on a listing of biodegradable fluid classes.

## 6. Fluid Properties and Performance Testing Procedures

6.1 The hydraulic fluid is a component of the total hydraulic system and to be used properly, various properties of the fluid must be considered relative to system design. These properties are determined by various tests procedures which include: physical properties, chemical properties, oxidative stability, corrosion, fire-resistance, biological and ecological compatibility, other bench tests, and pump tests. A summary of important fluid properties and associated test procedures is provided in Table 1.

NOTE 1—Every test is not appropriate for every fluid class shown in Table 1. The test procedures that are appropriate for a given fluid class are identified by an “X.”

NOTE 2—Every fluid test shown in the table need not be performed before for every pump test; however, it is recommended that after selecting those tests that are deemed most critical for the hydraulic fluid to be tested, that the test selection and properties of interest be reviewed with the component manufacturer to ensure that the fluid properties will meet the design and operational requirements for both the pump/motor/ components and the application of interest before the hydraulic piston pump test is conducted.

### 6.2 *Typical Physical Properties :*

6.2.1 *ISO Viscosity Grade (Classification D2422)*—The International Standards Organization has established a viscosity classification system for industrial fluid lubricants. Such lubricants are classified by grades designated as ISO-VG based on their viscosities in centistokes at 40°C. The choice of viscosity grade for use in a particular hydraulic system should meet the manufacturer’s recommendations.

6.2.2 *Viscosity (Test Methods D445 and D2983, and Practice D6080)*—Viscosity is the measurement of a fluid’s resistance to flow; it is considered to be the most important characteristic of a hydraulic fluid. The optimum value is always a compromise; it has to be high enough, at the working temperature, to ensure that the fluid will not leak through the seals or junctions and to maintain proper lubrication. Also, the viscosity has to be low enough to ensure fluid flow at start-up and to maintain system efficiency and lubrication and avoid cavitation.

6.2.2.1 High VI hydraulic fluids often contain high molecular weight thickeners, called viscosity index (VI) improvers, which may impart non-Newtonian characteristics to the fluid. These polymers may shear degrade with use, and reduce the in-service viscosity of the fluids. Practice D6080 provides uniform guidelines for characterizing oils in terms of both their high and low temperature viscosities before and after exposure to high shear stress. Since the performance of fluids at temperatures higher than 40°C is determined in the worst case, that is, most severe situation, by the sheared oil viscosity, the viscosity and viscosity index used to characterize fluids in this practice are those of the sheared fluid.

6.2.2.2 Practice D6080 classifies oils at low temperature by their new oil properties. Low temperature viscosities do not decrease greatly, if at all, with polymer shear degradation. Furthermore, this approach ensures that the fluid will be properly classified under worst-case conditions, that is, when the fluid is new. Practice D6080 may be used with new or used,

**TABLE 1 Hydraulic Fluid Physical Property Characterization Tests**

Characteristics	Hydraulic Fluid Classification												Test According to:
	HH	HL	HM	HV	HETG	HEES	HEPG	HEPR	HFA	HFB	HFD	HFC	
Kinematic viscosity at 40°C	X	X	X	X	X	X	X	X	X	X	X	X	ASTM D445
Low Temperature Viscosity	X	X	X	X	X	X	X	X	X	X	X	X	ASTM D2983, ASTM D6080
ISO Viscosity Grade	X	X	X	X	X	X	X	X	X	X	X	X	ASTM D2422
Viscosity Index	X	X	X	X	X	X	X	X	X	X	X	X	ASTM D2270
Pour point	X	X	X	X	X	X	X	X	X	X	X	X	ASTM D97
Density at 15°C	X	X	X	X	X	X	X	X	X	X	X	X	ASTM D1298, ASTM D4052
Air release at 50°C	X	X	X	X	X	X	X	X	X	X	X	X	ASTM D3427
Foam volumes (5 min. blowing, 10 min settling)	X	X	X	X	X	X	X	X	X	X	X	X	ASTM D892
Sequence I													
Initial Volume													
Final Volume, Time													
Sequence II													
Initial Volume													
Final Volume, Time													
Sequence III													
Initial Volume													
Final Volume, Time													
Emulsion stability at 54°C	X	X	X	X	X	X	X	X			X		ASTM D1401
Viscosity Stability (Ultrasonic Test)	X	X	X	X	X	X	X	X	X	X	X	X	ASTM D5621
Dielectric Breakdown Voltage (45-65 Hz)	X	X	X	X									ASTM D877
Electrical Conductivity at 20°C	X	X	X	X	X	X	X	X	X	X	X	X	ASTM D4308
Thermal conductivity	X	X	X	X	X	X	X	X	X	X	X	X	ASTM D2717
Specific heat capacity at 20°C	X	X	X	X	X	X	X	X	X	X	X	X	ASTM D2766
Vapor pressure	X	X	X	X	X	X	X	X	X	X	X	X	ASTM D2879
Bulk Modulus	X	X	X	X	X	X	X	X	X	X	X	X	ISO 6073
Fluid Cleanliness													
Instrumental Test Method	X	X	X	X	X	X	X	X	X	X	X	X	ISO 11171
Microscopic Test Method	X	X	X	X	X	X	X	X	X	X	X	X	ASTM F312, ISO 4407
Cleanliness Code	X	X	X	X	X	X	X	X	X	X	X	X	ISO 4406
In-Line Sampling Method	X	X	X	X	X	X	X	X	X	X	X	X	ISO 4021
Drum Sampling	X	X	X	X	X	X	X	X	X	X	X	X	ISO 5884
Sediment Content	X	X	X	X	X	X	X	X	X	X	X	X	ASTM D2273
Seal Compatibility	X	X	X	X	X	X	X	X	X	X	X	X	ASTM D6546
<b>Hydraulic Fluid Chemical Property Characterization Tests (Including Seal Compatibility)</b>													
Characteristics	Hydraulic Fluid Classification												Test According to:
	HH	HL	HM	HV	HETG	HEES	HEPG	HEPR	HFA	HFB	HFD	HFC	
Ash (sulfated ash) proportion by mass	X	X	X	X	X	X	X	X	X	X	X	X	ASTM D874, ASTM D482
Water content—Hydraulic Oils	X	X	X	X	X	X	X	X	X	X	X	X	ASTM D95, ASTM D1533, ASTM D6304, ASTM E203
pH value at 20°C									X	X			ASTM E70
Neutralization number	X	X	X	X	X	X	X	X	X	X	X	X	ASTM D664, ASTM D974
Alkaline Reserve to pH 5.5 (0.1N HCl)									X	X			ASTM D1121
Hydrolytic Stability (mg KOH, mg Cu/cm <sup>2</sup> )	X	X	X	X	X	X	X	X	X	X	X	X	ASTM D2619
Aniline Point	X	X	X	X	X	X	X	X	X	X	X	X	ASTM D611
<b>Hydraulic Fluid Thermal and Oxidative Stability, Corrosion and Bench Test Characterization Tests</b>													
Characteristics	Hydraulic Fluid Classification												Test According to:
	HH	HL	HM	HV	HETG	HEES	HEPG	HEPR	HFA	HFB	HFD	HFC	
Oxidation Stability—TOST	X	X	X	X	X	X	X	X			X		ASTM D943
Oxidation Stability—Cincinnati Milacron	X	X	X	X	X	X	X	X			X		ASTM D2070
Oxidation Stability—RBOT	X	X	X	X	X						X		ASTM D2272
Oxidation Stability—Baader Test	X	X	X	X	X	X	X	X			X		DIN 51554, Part 3
Oxidation Stability	X	X	X	X	X	X	X	X	X	X	X	X	DIN 51373
Sludging Tendency	X	X	X	X	X	X	X	X			X		ASTM D4310
Thermal Stability (Copper and Steel Rods, sludge)	X	X	X	X	X	X		X			X		ASTM D2070
Turbine Oil Rust Test	X	X	X	X	X	X	X	X	X	X	X	X	ASTM D665
Copper Corrosion	X	X	X	X	X	X	X	X			X		ASTM D130
Galvanic Corrosion	X	X	X	X	X	X	X	X	X	X	X	X	ASTM D6547
Vapor Phase Corrosion	X	X	X	X	X	X	X	X	X	X	X	X	ASTM D5534

Newtonian or non-Newtonian, hydraulic fluids. This practice is used for the determination of viscosities at low temperatures applicable to all hydraulic fluids based either on petroleum, synthetic, or naturally occurring base stocks. It is not intended for water-containing hydraulic fluids.

6.2.3 *Viscosity Index (VI) (Practice D2270)*—The VI number signifies the decrease of a fluid’s viscosity as the temperature increases. The greater the VI, the less viscosity changes with temperature. In general, the VI is not very critical when the system works at a stable operating temperature. When the

**TABLE 1** *Continued*

Hydraulic Fluid Thermal and Oxidative Stability, Corrosion and Bench Test Characterization Tests														
Characteristics	Hydraulic Fluid Classification												Test According to:	
	HH	HL	HM	HV	HETG	HEES	HEPG	HEPR	HFA	HFB	HFD	HFC		
Corrosion	X	X	X	X	X	X	X	X	X	X	X	X	X	LUX 5.9, ISO 4404
Aluminum														
Brass														
Cadmium														
Copper														
Magnesium														
Steel														
Zinc														
Steel and Zinc														
Copper and Zinc														
Aluminum and Zinc														
Steel and Aluminum														
Four-Ball Anti-wear	X	X	X	X	X	X	X	X	X	X	X	X	X	ASTM <b>D4172</b>
Four-Ball Extreme Pressure	X	X	X	X	X	X	X	X	X	X	X	X	X	ASTM <b>D2783</b>
FZG-gear rig test method	X	X	X	X	X	X	X	X	X	X	X	X	X	ASTM <b>D5182</b>
Vane pump anti-wear test	X	X	X	X	X	X	X	X	X	X	X	X	X	ASTM <b>D2882</b>
AFNOR Filterability (dry)	X	X	X	X	X	X	X	X	X			X		AFNOR NF E48-690
AFNOR Filterability (wet)	X	X	X	X	X	X	X	X	X					AFNOR NF E48-691
AFNOR Filterability (HDC and HFD)												X	X	AFNOR NF E48-692
ISO Filterability (Dry)	X	X	X	X	X	X	X	X	X			X		ISO 13357-2
Hydraulic Fluid Fire-Resistance Characterization Tests														
Characteristics	Hydraulic Fluid Classification												Test According to:	
	HH	HL	HM	HV	HETG	HEES	HEPG	HEPR	HFA	HFB	HFD	HFC		
Fire Point	X	X	X	X	X	X	X	X			X			ASTM <b>D92</b>
Flash Point (Open Cup)	X	X	X	X	X	X	X	X			X			ASTM <b>D92</b>
Determination of auto ignition temperature	X	X	X	X	X	X	X	X			X			ASTM <b>E659</b>
Factory Mutual Tests:									X	X	X	X		Factory Mutual Standard 6930
Hot Channel Ignition Test														
Spray Ignition Test														
Linear Flame Propagation Test											X			ASTM D5306
Hot Manifold Test									X	X	X	X		
Wick Flame Persistence									X	X	X	X		ISO 14935
Spray Flame Test									X	X	X	X		ISO 15029
Biodegradability	X	X	X	X	X	X	X	X	X	X	X	X	X	ASTM <b>D6006</b>
Classification for Environmental Impact	X	X	X	X	X	X	X	X	X	X	X	X	X	ASTM <b>D6046</b>
Hydraulic Fluid Fire-Resistance Characterization Tests														
Characteristics	Hydraulic Fluid Classification												Test According to:	
	HH	HL	HM	HV	HETG	HEES	HEPG	HEPR	HFA	HFB	HFD	HFC		
Biodegradability	X	X	X	X	X	X	X	X	X	X	X	X	X	ASTM <b>D6006</b>
Classification for Environmental Impact	X	X	X	X	X	X	X	X	X	X	X	X	X	ASTM <b>D6046</b>

variation of temperature among different points in the system is high (over 30°C), or the operational temperatures vary considerably, then a high VI (over 90) is usually recommended.

**6.2.4 Density—Relative Density (Test Methods D1298 and D4052)**—This property is of value to hydraulic system designers and operators for calculating system weight, internal pressure, wall thickness, and pump requirements. Density (or relative density) is measured at, or converted to, a standard reference temperature, normally either 15°C or 60°F, and these need to be quoted alongside the result. Test Method D1298 uses a hydrometer plus thermometer for measurement while Test Method D4052 uses a digital density meter.

**6.2.5 Pour Point (Test Method D97, Low Temperature Viscosity (Test Method D2983)**—The pour point is an indication of the lowest temperature at which an oil will flow by gravity. The fluid viscosity must allow the system to start up and operate at low temperatures. As a practical rule, the fluid should have a pour point 10°C below the minimum expected ambient temperature. Test Method D2983 can be used to

determine the temperature at which a fluid’s viscosity is less than 750 cP, which is suggested as the highest viscosity which the equipment can tolerate without risk of damage during operation.

**6.2.6 Shear Stability (Test Method D5621)**—Hydraulic fluids may be subjected to shear rates  $\geq 10^6 \text{ sec}^{-1}$ , which may lead to a permanent viscosity loss due to polymer additive degradation. Test Method D5621 covers the evaluation of the shear stability of a hydraulic fluid in terms of the final viscosity that results from irradiating a sample of the hydraulic fluid in a sonic oscillator. Evidence has been presented that a good correlation exists between the shear degradation that results from sonic oscillation and that obtained in a vane pump test procedure.

**6.2.7 Foaming Characteristics (Test Method D892)**—In oil systems having high circulation rates, it is important that air introduced through the seals or at the reservoir tank be readily released from the body of the fluid and not collect as foam on the surface of the fluid, since this can produce cavitation or



impede proper circulation. Test Method **D892** measures the tendency of the oil to form foam, and the stability of the foam. There are three sequences: Sequence I at 24°C; Sequence II at 93.5°C; and Sequence III at 24°C, using the same sample tested in Sequence II.

6.2.8 *Air Release (Test Method **D3427**)*—Agitation of lubricating oil with air in the equipment may produce a dispersion of finely divided air bubbles in the oil. If the residence time in the reservoir is too short to allow air bubbles to rise to the surface, a mixture of air and oil will circulate through the lubrication system. This may result in the inability to maintain oil pressure, incomplete oil films in contact zones, and poor hydraulic system performance or failure. This test measures the time for the entrained air content to fall to the relatively low value of 0.2 % volume under standardized test conditions, and hence permits the comparison of the oils' capacity to separate entrained air over a period of time.

6.2.9 *Water Separability (Demulsibility) Characteristics (Test Method **D1401**)*—Water in large hydraulic systems may be removed from water insoluble fluids by mechanical procedures that take advantage of the demulsibility properties of the oil. A contaminant in the emulsion can affect the viscosity of the circulating fluid, creating lubrication problems and may lead to deposits. Test Method **D1401** determines the gross water separation characteristics of oils.

NOTE 3—Many, if not most, used oils from Test Method **D1401** contain residual levels of water equal to or exceeding amounts sufficient to shorten oil life. Therefore, rapid water separation in Test Method **D1401** does not imply that testing oils with low levels of water contamination should not be done.

6.2.10 *Thermal Conductivity (Test Method **D2717**) and Specific Heat (Test Method **D2766**)*—The thermal conductivity and specific heats of hydraulic fluids are important fluid design parameters. These properties may be determined from Test Methods **D2717** and **D2766** respectively.

6.2.11 *Electrical Conductivity (Test Methods **D2624**)*—The ability of a fluid to dissipate charge during pumping and filtering operations is controlled by its electrical conductivity, which depends on the content of ionic species. Electrical conductivity is an important parameter in determining the potential for a hydraulic fluid to cause electrochemical erosion (chemical pitting). Hydraulic fluid conductivity may be determined by Test Methods **D2624**.

6.2.12 *Dielectric Breakdown Voltage (Test Method **D877**)*—Some users require that a minimum breakdown voltage be reported for applications like cherry pickers working near electric lines. This test method is used to judge if the disk electrode breakdown voltage requirements are met for insulating liquids, as delivered from the manufacturer, that have never been filtered or dried. (See Specification **D3487**, Specification **D4652**, and Guide **D5222** for the minimum specified electrical breakdown.) The breakdown test uses ac voltage in the power-frequency range from 45 to 65 Hz. The sensitivity of this test method to the general population of contaminants present in a liquid sample decreases as applied test voltages used in this test method become greater than approximately 25 kV rms. If the concentration of water in the sample at room temperature is less than 60 % of saturation, the sensitivity of this test method to the presence of water is decreased.

6.2.13 This test method describes two procedures, A and B, for determining the electrical breakdown voltage of insulating liquid specimens.

6.2.13.1 Procedure A is used to determine the breakdown voltage of liquids in which any insoluble breakdown products easily settle during the interval between the required repeated breakdown tests. These liquids include petroleum oils and hydrocarbons.

6.2.13.2 Procedure B is used to determine the breakdown voltage of liquids in which any insoluble breakdown products do not completely settle from the space between the disks during the 1-min interval required in Procedure A (6.2.13.1). Procedure B should also be applied for the determination of the breakdown voltage of liquid samples containing insoluble materials that settle from the specimen during testing. These examples represent samples that may have large differences between replicate tests. The use of Procedure B will result in a more accurate value of breakdown voltage when testing such liquids. Use Procedure B to establish the breakdown voltage of an insulating liquid where an ASTM specification does not exist or when developing a value for an ASTM guide or standard. Procedure A may be used once its single operator precision has been demonstrated.

6.2.14 *Resistivity (Test Method **D1169**)*—Resistivity ( $\rho$ ) is the property of a material which determines its resistance to flow of an electric current, expressed by:

$$\rho = R \cdot A / l \quad (8)$$

where:

$R$  = resistance of the specimen,  $\Omega$ ,

$A$  = cross-sectional area,  $\text{cm}^2$ , and

$l$  = length of the specimen, cm.

Resistivity is the inverse of conductivity. Resistivity is an important parameter in determining the potential for electrochemical erosion (pitting corrosion) in a hydraulic system (1).<sup>12</sup> High resistivity reflects low content of free ions and ion-forming particles, and normally indicates a low concentration of conductive contaminants. Test Method **D1169** involves the use of a dc galvanometer to measure electrical current flow in a test cell containing the hydraulic fluid.

6.2.15 *Vapor Pressure (Test Method **D2879**)*—One of the most critically important properties which must be accommodated in hydraulic system design is the vapor pressure of a hydraulic fluid at its operating temperature. If the vapor pressure is sufficiently high, the potential for cavitation may increase dramatically. Vapor pressure may be measured using an isotenoscope by Test Method **D2879**. This test method measures the vapor pressure of the fluid as received, including most volatile components, but it excludes dissolved fixed gases such as air.

6.2.16 *Bulk Modulus (Test Method ISO 6073)*—Bulk modulus is a measure of the resistance to compressibility. The bulk modulus of a hydraulic fluid is important because power is transmitted and controlled under pressure in a hydraulic circuit. Test Method ISO 6073 (NFPA/T2.13.7R1-1996) provides a

<sup>12</sup> The boldface numbers in parentheses refer to a list of references at the end of this standard.

procedure for predicting the bulk moduli of hydraulic fluids. In this test method, it is assumed that there are no gas bubbles in the fluid. The useful temperature range is from 0 to 270°C with a pressure range from atmospheric to 700 000 kPa (7000 bar).

**6.2.17 Elastomer Compatibility (Test Methods D6546)**—Test Methods **D6546** provide procedures for measuring physical properties of elastomer seals in the form of O-rings after exposure to industrial hydraulic fluids and thermal aging. The measured properties are then compared to the physical properties of elastomer seals that have not been exposed to the industrial hydraulic fluids and thermal aging. The changes in these properties form a basis for assessing compatibility when these changes are compared against the suggested limits.

**6.2.17.1** These test methods provide procedures for exposing O-ring test specimens to industrial hydraulic fluids under definite conditions of temperature and time. The resulting deterioration of the O-ring material is determined by comparing the changes in work function, hardness, physical properties, compression set, and seal volume after immersion in the test fluid to the pre-immersion values.

**6.2.18 Sediment Content (Test Method D2273)**—This test method covers the determination of trace amounts (less than 0.05 volume %) of sediment in lubricating oils. Since oil-soluble material precipitated by the specified solvent is not intended as part of the measured sediment, this test method is not applicable in cases where precipitated oil-soluble components will appreciably contribute to the sediment readings.

**6.2.19 Fluid Cleanliness (Test Method ISO 4406, 4021, and 11171)**—Fluid cleanliness is an important parameter since dirt contaminants and wear debris may lead to erosive or abrasive wear in the system and interfere with the operation of various components such as servovalves. Therefore, reliable system performance requires contamination monitoring and control procedures.

**6.2.19.1** Qualitative and quantitative determination of the particulate contaminants in a hydraulic fluid requires precision in obtaining the sample and determination of the nature and extent of the contaminant in addition to particle size and concentration. Hydraulic fluid samples must be representative of the particle contaminant in the fluid flowing at the point of sampling. The most representative sample is obtained from the system while the fluid is flowing in a turbulent manner. Line sampling procedures that provide the necessary representative system cleanliness results are described in detail in ISO 4021. A fluid samples taken in this manner is designated as a dynamic sample. There are several procedures and devices for sampling drums, barrels, etc. such as ISO 5884. Liquid automatic particle counters are an accepted means of determining the concentration and size distribution of the contaminant particles. Individual instrument accuracy is established through calibration. ISO 11171 provides procedures for:

- (1) Primary particle-sizing, sensor resolution, and counting performance;
- (2) Secondary particle-sizing calibration using suspensions prepared with NIST reference materials;
- (3) Establishing acceptable operation and performance limits;

- (4) Verifying particle sensor performance using a truncated test dust procedure; and

- (5) Determining coincidence and flow rate limits in the particle counter.

NOTE 4—ISO 11171 replaces the ISO 4402 method of calibrating automatic particle counters which is now obsolete.

**6.2.19.2** Quantitative counting of particles may also be performed by microscopic counting. The microscopic technique is described in Test Methods **F312** and ISO 4407. Thus far, there is no standard procedure that has been reported for the use of automatic particle counters, although there are calibration procedures using a synthetic test dust (see ISO 11171). The test dusts are designated as are ISO Ultrafine, ISO Fine, ISO Medium, and ISO Coarse.

**6.2.19.3** The coding procedure for contaminant number and size distribution to be used in defining the quantity of solid particles in the fluid in a given hydraulic system is described in ISO 4406. This test method provides a three-part code for contamination levels measured with automatic particle counters calibrated in accordance with ISO 11171. The reported particle sizes are 4 μm, ≥6 μm, and ≥14 μm. It also introduces equivalent particle sizes for such counters, based on calibration with NIST reference material SRM 2806.

### 6.3 Typical Chemical Properties :

**6.3.1 Neutralization Number (Test Methods D664 and D974)**—Oxidation of hydraulic fluids may be monitored by tracking increases in the acid number. Because the fresh fluid may be either alkaline or acidic, depending on the additives present, the value of the acid number of the fresh fluid is not indicative of quality. However, increasing acid numbers generally indicate increasing amounts of oxidation.

NOTE 5—With ester-based fluids, the acid number of the fresh fluid is indicative of quality, since esters hydrolyze quicker in the presence of acid.

**6.3.1.1** The acid number is determined by titrating a sample of known size with a known amount of standard base (Test Methods **D664** or **D974**). The test is performed by dissolving the oil in a mixture of toluene and isopropanol, to which has been added a small amount of water, then titrating it with a standard solution of potassium hydroxide (KOH). The end-point may be determined potentiometrically or colorimetrically with a pH-sensitive indicator. The acid number (AN) is reported in units of milligrams of KOH per gram of sample (mg KOH/g). It should be noted that the acid number obtained by Test Method **D974** may or may not be numerically the same as those obtained by Test Method **D664**, but it is generally of the same order of magnitude.

**6.3.2 Hydrolytic Stability (Test Method D2619)**—The resistance of hydraulic fluids to hydrolysis is important. Reaction of a finished product with water can lead to the formation of corrosive substances, acids, insoluble by-products, and stable emulsions which can, in turn, cause corrosion, sticky valves, plugged filters, and change in oil viscosity. However, some hydraulic fluids are not hydrolytically stable (see Specification **D4293**). Hydrolytic stability may be evaluated by the Beverage Bottle Test (Test Method **D2619**) where the hydraulic fluid and water are heated at 200°F for 48 h in the presence of a copper

test specimen. Changes in viscosity and acid number of the fluid and acid number of the aqueous layer are determined after the test. Copper weight change and appearance are also measured.

6.3.3 *Water Content (Test Methods D1123, D1533, D6304, D95, and E203)*—The presence of water in a hydraulic oil, which may be present due to condensation or a leaking heat exchanger, presents a potentially serious problem. Test Methods **D1123**, **D1533**, and **D6304** are quantitative tests for water content which uses the reaction of water with Karl Fischer chemical reagent as its basis, and a coulometric end point as the measurement. Test Method **D1533** is used for water contents <200 ppm and Test Method **D6304** is used when the water content is in the range from 10 to 25 000 mg/kg (0.1 mass %). The components of some fluids may react with the reagent to give misleading results.

6.3.3.1 Test Method **E203** is intended as a general guide for the application of the volumetric Karl Fischer (KF) titration for determining free water and water of hydration in most solid or liquid organic and inorganic compounds. This test method is designed for use with automatic titration systems capable of determining the KF titration end point amperometrically; however, a manual titration method for determining the end point visually is included. This test method covers the use of both pyridine-containing and pyridine-free KF reagents for determining water by volumetric titration. Determination of water using KF coulometric titration is not discussed. By proper choice of the sample size, KF reagent concentration, and apparatus, this test method is suitable for measurement of water over a wide concentration range, that is, from parts per million to pure water.

6.3.3.2 For relatively high concentrations of water, Test Method **D95**, a distillation method, may be used for water concentrations of 0–25 %. (Test Method **E203** is useful for water concentrations varying from the parts per million (ppm) range to pure water.)

6.3.3.3 Fire-resistant hydraulic fluids, including HFA, HFB, and HFC fluids, have water contents of  $\geq 35$  %. In these fluids, water is not a contaminant but a necessary component and the water concentration must be determined and maintained to ensure adequate fire resistance and hydraulic system performance. Water content may be determined by azeotropic distillation according to Test Method **D95** or by Karl Fischer Analysis according to Test Method **E203**.

6.3.4 *Ash Content (Test Method D482)*—Test Method **D482** covers the determination of ash in the range from 0.001 to 0.180 mass %, from distillate and residual fuels, gas turbine fuels, crude oils, lubricating oils, waxes, and other petroleum products, in which any ash-forming materials present are normally considered to be undesirable impurities or contaminants (see **Note 6**). This test method is limited to petroleum products which are free from added ash-forming additives, including certain phosphorus compounds (see **Note 7**).

**NOTE 6**—In certain types of samples, all of the ash-forming metals are not retained quantitatively in the ash. This is particularly true of distillate oils, which require a special ash procedure in order to retain metals quantitatively.

**NOTE 7**—This test method is not intended for the analysis of unused lubricating oils containing additives; for such samples, use Test Method

**D874** (see 6.3.5). Neither is it intended for the analysis of lubricating oils containing lead nor for used engine crankcase oils.

6.3.5 *Sulfated Ash Content (Test Method D874)*—Test Method **D874** covers the determination of the sulfated ash from unused lubricating oils, such as hydraulic fluids, containing additives and from additive concentrates used in compounding. These additives usually contain one or more of the following metals: barium, calcium, magnesium, zinc, potassium, sodium, and tin.

**NOTE 8**—This test method is not intended for the analysis of used engine oils or oils containing lead. Neither is it recommended for the analysis of nonadditive lubricating oils, for which Test Method **D482** can be used.

**NOTE 9**—There is evidence that magnesium does not react the same as other alkali metals in this test method. If magnesium additives are present, the data should be interpreted with caution.

**NOTE 10**—There is evidence that samples containing molybdenum or boron can give low results because compounds of these metals are not fully recovered at the temperature of ashing.

6.3.6 *pH Determination (Test Method E70)*—Test Method **E70** specifies the apparatus and procedures for the electrometric measurement of pH values of aqueous solutions with the glass electrode. It does not deal with the manner in which the solutions are prepared. The pH measurements of good precision can be made in aqueous solutions containing high concentrations of electrolytes or water-soluble organic compounds, or both. It should be understood, however, that pH measurements in such solutions are only a semiquantitative indication of hydrogen ion concentration or activity. The measured pH will yield an accurate result for these quantities only when the composition of the medium matches approximately that of the standard reference solutions. In general, this test method will not give an accurate measure of hydrogen ion activity unless the pH lies between 2 and 12 and the concentration of neither electrolytes nor nonelectrolytes exceeds 0.1 M.

6.3.7 *Alkaline Reserve to pH 5.5 (Test Method D1121)*—Many water-containing hydraulic fluids, such as HFC fluids, contain amines or basic salts as corrosion inhibitors. The total inhibitor content may be quantitatively determined using a titrimetric procedure by titrating to a pH of 5.5 using 0.1 N HCl and a glass electrode. This procedure is described in Test Method **D1121**.

6.3.8 *Aniline Point (Test Method D611)*—Elastomer compatibility is affected by the composition of the mineral oil. The potential for a mineral oil to cause swelling or shrinkage of a seal is important if optimal seal strength is to be maintained and leakage is to be minimized. One of the oldest methods of estimating hydraulic seal compatibility with a mineral oil is the aniline point of the fluid. Generally, fluids with low aniline points cause the highest swelling with neoprene and BUNA-N nitrile rubber (see **Note 11**) and fluids with high aniline points may cause seal shrinkage.

6.3.8.1 The aniline point (or mixed aniline point) described by Test Method **D611** is useful as an aid in the characterization of pure hydrocarbons and in the analysis of hydrocarbon mixtures. The test is conducted with specified volumes of aniline and sample, or aniline and sample plus n-heptane, which are placed in a tube and mixed mechanically. The

mixture is heated at a controlled rate until the two phases become miscible. The mixture is then cooled at a controlled rate and the temperature at which two phases separate is recorded as the aniline point or mixed aniline point. Aromatic hydrocarbons exhibit the lowest, and paraffins the highest values. Cycloparaffins and olefins exhibit values that lie between those for paraffins and aromatics.

NOTE 11—Although generally true, it has not been possible to calibrate the aniline point of an oil to predict the swelling of various elastomeric seal compositions with respect to different base oils and additive combinations. For example, ester-based hydraulic fluids often aid seal swell problems and they may be used to counteract the tendency of hydrocarbon-based fluids to shrink seals. Also, some fluids contain seal swell additives.

#### 6.4 Tests for Thermal and Oxidation Stability:

6.4.1 *Thermal Stability—Cincinnati Milacron Test (Test Method D2070)*—The thermal degradation of a lubricant can yield by-products which corrode metals, as well as insoluble materials which plug filters and block narrow clearances. This test method is designed primarily to evaluate the thermal stability of hydrocarbon-based hydraulic oils in the presence of copper and steel at 135°C although oxidation may occur during the test. The colors of the test rods are the evaluation criteria. The tendency of oils to form sludge at high temperatures in the absence of water and in the presence of iron and copper is also reported.

6.4.2 *Oxidation Stability—Turbine Oil Stability Test (Test Method D943)*—Oxidation of the oil may increase oil viscosity, produce sludge that can make valves stick and plug filters, and generate materials which are corrosive to metals. Test Method D943, also known as Turbine Oil Stability Test (TOST), measures the time that the oil resists oxidation in the presence of oxygen, water, and metal catalysts. It should be recognized, however, that correlation between results of this test method and the oxidation stability of a lubricant in field service can vary markedly with field service conditions. This test method does not measure sludge formation or catalyst coil corrosion (see Test Method D4310).

6.4.3 *Oxidation Stability (Test Method D2272)*—This test, familiarly known as the Rotating Bomb Oxidation Test (RBOT), utilizes an oxygen-pressured vessel to evaluate the oxidation stability of new and in-service turbine oils having the same composition (base stock and additives) in the presence of water and a copper catalyst coil at 150°C. The estimate of oxidation stability is useful in controlling the continuity of this property for batch acceptance of production lots having the same operation. This test method is also used to assess the remaining oxidation life of in-service oils. Although it was developed for turbine oils, it is routinely used for other industrial lubricants, including hydraulic oils.

6.4.4 *Oxidation Stability—Baader Test (DIN 51554-3)*—Neither Test Method D943 (TOST) nor Test Method D2272 (RBOT) discussed in 6.4.2 and 6.4.3 is suitable for use with hydrolytically unstable hydraulic fluids such as vegetable oil-based fluids, synthetic esters, or polyol esters, since water is used as a component of the test procedure (see Note 12). One test that has been used to determine the oxidative stability of hydrolytically sensitive fluids is DIN 51554-3, also known as the Baader test. It is conducted at 95°C for three days in the

presence of air and a copper wire catalyst. At that point, the fluid is visually examined and then the saponification number is determined.

NOTE 12—Recent work in ASTM D02.N0.03 has shown that if Test Method D943 is conducted without the addition of water (dry), this modified test provides a suitable assessment of the oxidative stability of vegetable oils.

6.4.5 *Oxidation Stability of Phosphate Ester Fluids (DIN 51373)*—Another test that is reported in ISO 12922 for determination of the oxidative stability of fire-resistant phosphate ester-based hydraulic fluids is DIN 51373. This test method characterizes resistance to oxidation and provides a measure of resistance to corrosion of copper and steel. This test is performed by passing oxygen at 1 L/h for 164 h through the test solution while maintaining the temperature at 120°C. Volatile acidic by-products are collected in water contained in a downstream absorption tube. At the conclusion of the test, the acid number is determined in the test fluid and the acids collected in the absorption tube are titrated with base and reported as mg KOH/g of the test fluid. The change in mass of the copper and iron specimens is determined.

6.4.6 *Sludging Tendency (Test Method D4310)*—As stated in Oxidation Stability (Test Method D943), insoluble or corrosive materials may form in oils when they are subjected to oxidation conditions. This 1000-h test determines the tendency of oil to form sludge in the presence of oxygen, water, and metal catalysts. Test Method D4310 also measures the total copper present in the oil, water, and sludge phases. It is a complement to Test Method D943.

#### 6.5 Typical Corrosion Properties :

6.5.1 *Rust Preventing Characteristics (Test Method D665)*—This test method measures the ability of the oil to prevent rusting of steel surfaces when water is present. Procedure A uses distilled water, and Procedure B uses synthetic sea water. The procedure also provides for testing heavier-than-water fluids.

6.5.2 *Copper Corrosion Characteristics (Test Method D130)*—Some components of hydraulic systems contain copper alloys (for example, vane pump bushings and piston pump shoes). This test method covers the detection of the corrosiveness to copper of hydraulic oils and other hydrocarbons having a Reid vapor pressure no greater than 18 psi (124 kPa).

6.5.3 *Vapor Phase Corrosion Characteristics (Test Method D5534)*—Test Method D5534 evaluates the ability of a water-containing hydraulic fluid to prevent rusting of steel in the vapor phase over the hydraulic fluid and water.

6.5.4 *Determination of the Corrosion-Inhibiting Properties of Fluids (Test Method LUX 5.9)*—It is important that fire-resistant hydraulic fluids do not cause corrosion of the equipment in which they are used. The tests described in Section 5.9 of the Seventh Luxembourg Report (also see ISO 4404) are designed to determine corrosion-inhibiting properties of the fluids in contact with selected metals or metal pairs.

6.5.4.1 One of the testing methods described is characterized by a low test temperature (35°) and a long duration of 28 days. The second testing method is similar except a higher testing temperature (60°C) and a shorter testing time of 14 days is used.

**6.5.5 Galvanic Corrosion (Test Method D6547)**—Galvanic corrosion is recognizable by the appearance of increased corrosion near the junction of dissimilar metals. This is caused by an electrochemical reaction between metals. The propensity for galvanic corrosion is dependent on the position of the two metals in the galvanic series. Any metal will have a greater tendency to corrode when it is in contact with another metal in a lower position in the series in the presence of an electrolyte. The farther apart the two metals in the series, the greater the potential for galvanic attack.

**6.5.5.1 Test Method D6547** provides a test method for determination of the corrosiveness of hydraulic and lubricating fluids to a brass on steel galvanic couple at ambient temperature and 50 % relative humidity. This test method consists of fitting a brass clip to the fluid-coated surface of a steel disk, storing the assembly at approximately 50 % relative humidity for ten days, and visually inspecting the assembly for evidence of galvanic corrosion.

**6.6 Selected Tests for Fire Resistance**—Fire resistance tests are established by various authorities, depending on the industry and country where the hydraulic fluid will be used. An exhaustive global listing of these tests is beyond the scope of this guide. Ref (2) provides a more comprehensive overview of fire-resistance testing than is possible here (2). However, assessment of fire resistance is often a criterion of fluid selection. Therefore, some of the more common tests used in Europe and the United States are provided for reference in Table 1.

**6.6.1 Flash Point and Fire Point (Test Methods D92 and D93)**—Flash point is defined as the lowest temperature corrected to barometric pressure of 101.3 kPa (760 mm Hg) at which the application of an ignition source causes the vapors of a test specimen of the sample to ignite under specified conditions of the test. Experimentally, the flash point is determined by passing a flame over a test specimen contained in a test cup and heated at a constant rate. The flash point is determined to be that temperature where the fluid will flash but not continue to burn when a flame is passed over the cup. It is indirectly a measure of both the volatility of the oil and flammability of the volatiles contained therein. The fire point of a fluid is defined as the lowest temperature corrected to barometric pressure of 101.3 kPa (760 mm Hg) at which the application of an ignition source causes the vapors of a test specimen of the sample to ignite and sustain burning for a minimum of 5 s under specified conditions of the test.

**6.6.1.1 Test Method D92** describes the determination of flash and fire points of a fluid using the Cleveland Open Cup (COC) test procedure. Test Methods D93 describes the determination of flash point under closed cup conditions using the Pensky-Martens Closed Cup Tester.

**6.6.2 Autoignition Temperature (Test Method E659)**—Autoignition is the temperature at which the fluid will ignite spontaneously in contact with air. This test method covers the determination of hot- and cool-flame autoignition temperatures of a liquid chemical in air at atmospheric pressure in a uniformly heated vessel.

**6.6.3 Linear Flame Propagation Test (Test Method D5306)**—Test Method D5306 covers the determination of

linear flame propagation rates of hydraulic fluids supported on the surfaces of, and when impregnated into, ceramic fiber media. The linear flame propagation rate is a property that is relevant to the overall assessment of the flammability or relative ignitability of fire-resistant hydraulic fluids.

**6.6.4 Other Fire Resistance Testing Methods**—Various fire resistance tests are summarized in Table 1. However, two of the most common testing procedures encountered in the United States are the Factory Mutual Test 6930 and the Mine Safety and Health Administration (MSHA) tests cited in CFR Part 35(3).

**6.6.4.1 Factory Mutual Test Method D6930 (4)**—This is a two part test procedure. The first part is a hot channel spray flammability test where the hydraulic fluid is sprayed onto a metal surface for 60 s, after it is preheated to 1300°F (704°C) and the burners are turned off. In order to be considered a “pass” in this test, the fluid must not propagate and must not follow the spray source. The second part is a spray ignition flammability test where a propane torch flame is rotated through a spray of the hydraulic fluid. The fluid spray flame, if established, must be self-extinguishing within 5 s after removal of the ignition source in order to be considered a “pass.”

**6.6.4.2 Mine Safety and Health Administration (MSHA) CFR Part 35 Test Method (3)**—The CFR Part 35 Test Method contains three parts and a hydraulic fluid must pass all three parts. The first part is an autoignition temperature (AIT) test which is conducted according to Test Method E659. If the AIT is >600°F, the fluid is considered a “pass.” The second part is a temperature-pressure spray ignition test. If the fluid flame, if formed, self-extinguishes in <1 min, it is considered a “pass.” The third part of this test evaluates the effect of evaporation on flammability. It is also commonly called the “pipe cleaner” test. In this test, a pipe cleaner saturated with the hydraulic fluid being tested is cycled through a Bunsen burner flame at 25 ± 2 cycles/min. To be considered a “pass,” the average number of cycles through the flame before ignition shall be at least 24.

**6.7 Biodegradability and Aqueous Toxicity**—Although the biodegradability and ecotoxicity properties of a hydraulic fluid do not dictate their performance in a hydraulic pump, they are often important screening properties. In many cases, if a hydraulic fluid does not exhibit acceptable biodegradability and ecotoxicity, it will be rejected and not be evaluated in expensive and time-consuming pump tests.

**6.7.1 Biodegradability (Guide D6006)**—Guide D6006 provides information to assist in judging the biodegradability of an unused fully formulated hydraulic fluid in its original form. Biodegradability is one of three characteristics which are assessed when judging the environmental impact of a hydraulic fluid. The other two characteristics are ecotoxicity and bioaccumulation. Biodegradability may be considered by type of environmental compartment: aerobic fresh water, aerobic marine, aerobic soil, and anaerobic media. Test methods for aerobic fresh water-, aerobic soil and anaerobic media have been developed that are appropriate for the concerns and needs of testing in these compartments.

**6.7.1.1 Guide D6006** addresses releases to the environment that are incidental to the use of a hydraulic fluid but is not intended to cover situations of major, accidental release.

Nothing in this guide should be taken to relieve the user of the responsibility to properly use and dispose of hydraulic fluids.

**6.7.2 Classification of Fluids for Environmental Impact (Classification D6046)**—This classification establishes a framework to categorize the biodegradability, toxicity, and bioaccumulation impact of hydraulic fluids on different environmental compartments. Fluids are assigned designations within these categories; for example Pw1, Tw2, and so forth, based on performance in specified tests.

**6.7.3** In the current version of this classification, the aspects of environmental impact included are environmental persistence (biodegradability) and acute ecotoxicity. Although environmental persistence is discussed first, this classification does not imply that considerations of environmental persistence should take precedence over concerns for ecotoxicity. Another important aspect of environmental impact is bioaccumulation. This aspect is not addressed in the present classification because adequate test methods do not yet exist to measure bioaccumulation of hydraulic fluids. The present classification addresses the fresh water and soil environmental compartments. At this time marine and anaerobic environmental compartments are not included, although they are pertinent for many uses of hydraulic fluids. Hydraulic fluids are expected to have no significant impact on the atmosphere; therefore, that compartment is not addressed.

**NOTE 13**—This classification addresses the potential impact of releases to the environment which are incidental to the use of a hydraulic fluid. The classification is not intended to address environmental impact in situations of major, accidental release.

**6.8 Filterability**—Petroleum oil may be difficult to filter in the presence of small amounts (<2 %) of water. In some cases, this may result in plugging of system filters which may result in increased abrasive wear of the hydraulic system components. It should be noted that filterability is not a physical characteristic of the oil but represents an estimation of its behavior in service. Therefore, an assessment of the filterability of hydraulic oils is very important.

**6.8.1 Filterability (AFNOR Test Methods NF E48-690, NF E48-691, NF E48-692, ISO 13357-2)**—Fluid filterability for petroleum oil-derived fluids is measured using a filtration membrane made of mixed cellulose esters for AFNOR NF E48-690 and AFNOR NF E48-691. The membrane area (47 mm diameter) and pore size (0.8 μm) are defined (Millipore AA WP 047 IF). The AFNOR NF E48-690 test method is used to assess the filterability of an oil which will be used in applications where the presence of water in the oil is unlikely. The AFNOR NF E48-691 test method is used for assessing the filterability of oils that have been heat-soaked in the presence of water contamination.

**NOTE 14**—It is not impossible for an oil to have poor filterability when dry, but good filterability when wet although it is unlikely that such an oil would be generally acceptable.

**6.8.1.1** The “wet” oil samples are prepared by mixing 330 mL of oil with 66 mL of water and then heat the mixed sample in an oven at 70°C for 2 h. The sample is removed from the oven, stirred again and then returned to the oven for 70 h at which time the sample is removed from the oven and stored at ambient temperature in the dark for 24 h at which time it is

ready for filterability testing. In the AFNOR test methods, the rate of filtration near the beginning of the test is measured, and compared with the mean filtration rate throughout the test, or with the rate at the end of the test. The filterability calculation procedure affords a value that is independent of fluid viscosity, however, a constant fluid temperature must be maintained throughout the test.

**6.8.1.2** Alternatively, filterability of petroleum oil hydraulic fluids may be assessed using ISO 13357-2. As with the AFNOR procedures above, these test methods are not suitable for use with HFC and HFD fire-resistant fluids due to their incompatibility with the filter material.

**NOTE 15**—The AFNOR NF E48-69 (ISO 13357-2) and AFNOR NF E48-691 test procedures are not suitable for some hydraulic oils on which specific properties have been conferred by the use of insoluble/partially soluble additives, or by particularly large molecular species.

**6.8.1.3** For fire-resistant fluids, HFC and HFD, a filter membrane made of polytetrafluoroethylene (Millipore Fluoropore FALP 047 IF) is used for AFNOR NF E48-692. Both the membrane area (47 mm diameter) and pore size (1 μm) are defined.

**6.9 Anti-wear Performance**—Preliminary assessment of the lubricating performance of a hydraulic fluid is typically performed prior to conducting relatively expensive and time-consuming piston pump tests. These preliminary tests can be classified as “bench” tests and “pump” tests. The bench tests are standardized lubrication tests and the most commonly encountered are described in **6.9.1**. The most common pump tests used for hydraulic fluid lubrication testing are either the Test Method **D2882** vane pump test or the Eaton 35VQ25 vane pump test (**5**).

**NOTE 16**—The vane pump tests described in **6.9** for assessing hydraulic fluid lubrication provide an excellent indication of anti-wear performance under pure sliding conditions. Such information is a useful indicator for lubrication wear at sliding contacts in a piston pump which include: the interface between the piston and the cylinder block, the interface between the piston and the swash plate for some axial piston pumps, the interface between the rotary valve plate and pump housing, and other wear surfaces. However, correlation must be established by either experiment or experience.

**6.9.1 Assessment of Anti-wear and EP Performance—Bench Tests:**

**6.9.1.1 Shell Four-Ball Tests (Test Methods D2783 and D4172)**—Although of limited value for water-containing fluids due to lack of fluid temperature control, four-ball tests may provide a useful preliminary evaluation of the lubricating properties of a hydraulic fluid.

**(1) Evaluation of Extreme Pressure (Load Carrying) Properties by the Four Ball Method (Test Method D2783)**— This test method covers the determination of the load-carrying properties of lubricating fluids including hydraulic fluids. Two determinations are made: load-wear index (formerly Mean-Hertz load) and the weld point by means of the four-ball extreme-pressure (EP) tester.

**(2) Evaluation of Anti-wear Properties by the Four-Ball Method—(Test Method D4172)**—This test method covers a procedure for making a preliminary evaluation of the anti-wear properties of fluid lubricants in sliding contact by means of the Four-Ball Wear Test Machine.

**TABLE 2 Current Pump Testing Procedures Based on the Eaton V-104 Vane Pump**

Procedure	Fluid Volume, L	Time, h	Pump Speed, rpm	Outlet Pressure, bar	Inlet Temperature or Viscosity, <sup>A</sup> C/cSt	Power Requirement, kW
ASTM <b>D2882</b>	57	100	1200	140	<sup>B</sup>	7
DIN 51389/2 <sup>C</sup>	70	250	1500	140	13 cSt	7
DIN 51389/3 <sup>C</sup>	70	250	1500	105	13 cSt	7
IP 281	70	250	1500	102	13 cSt	7
CETOP RP 67	70	250	1500	102	13 cSt	7

<sup>A</sup> Test Method **D2882** specifies the operating conditions by fluid temperature where the DIN 51389, IP 281, and CETOP methods specify that the running temperature will be selected to provide a fluid viscosity of 13 cSt.

<sup>B</sup> Fluid temperature at the pump inlet is  $66 \pm 3^\circ\text{C}$  ( $150 \pm 5^\circ\text{F}$ ) for all water glycols, emulsions, and other water-containing fluids and for petroleum and synthetic fluids with  $66 \pm 3^\circ\text{C}$  ( $150 \pm 5^\circ\text{F}$ ) viscosities of 46 cSt (213 SUS) or less. A temperature of  $80 \pm 3^\circ\text{C}$  ( $175 \pm 5^\circ\text{F}$ ) is used for all other synthetic and petroleum fluids.

<sup>C</sup> This is the test method for mineral oil hydraulic fluids. DIN 51389/3 is the method for fire-resistant fluids.

6.9.1.2 *FZG Test (Test Method D5182)*—This test method, the Forschungstelle für Zahnrad und Getriebebau (Research Site for Gears and Transmissions) Visual Method, commonly referred to as the FZG Visual Method, is intended to measure the scuffing load capacity of oils used to lubricate hardened steel gears. It is primarily used to assess the resistance to scuffing of mild additive treated oils such as industrial gear oils and transmission fluids. This test is widely used to predict anti-wear performance of hydraulic oils in vane pumps.

6.10 *Assessment of Anti-wear Performance—Vane Pump Tests:*

6.10.1 *Anti-wear Performance (Test Method D2882)*—Hydraulic systems running at high pressures, designed with small clearances and subject to metal-to-metal contact (for example, vane, gear, and piston pumps) should use fluids that have anti-wear properties. Test Method **D2882** is a constant-volume vane pump test based on the Eaton V104C vane pump (see **Note 17**). The evaluation parameter is the total weight loss of the ring and vanes. The test rig simulates anti-wear performance provided by a hydraulic fluid at a sliding wear contact in small hydraulic systems.

**NOTE 17**—Various national test methods have been issued based on the Eaton V-104C pump but with slightly varying test conditions. A summary of various test methods and testing conditions is provided in **Table 2**.

**NOTE 18**—Test Method **D2882** is based on the use of the Eaton V104C vane pump. However, the V104 pump and components are no longer available from Eaton. Therefore, this test is currently being performed with replacement parts which are similar but not identical to certified Eaton replacement parts.

6.10.2 *Eaton 35VQ25 Vane Pump Test*—For many higher pressure and higher speed operating conditions, a more rigorous assessment of hydraulic fluid anti-wear properties is necessary. Therefore, Vickers Inc. developed the 35VQ25 vane pump test (now designated as the Eaton 35VQ35 vane pump test, to provide the most severe evaluation of hydraulic fluid anti-wear performance in a Vickers intravane pump (5). The procedure for this test is outlined in Vickers Form No. M-2952-S, now published by Eaton Corporation (6). The test procedure involves the use of an Eaton 35VQ35 fixed displacement ( $81 \text{ cm}^3/\text{rev}$ ) vane pump as the test pump. This pump utilizes an intravane design replaceable cartridge which is rated at 2500 rpm and 207 bar (3000 psi). The test procedure utilizes a minimum of three vane pump cartridges which are tested at 50 h each. The 50 h test duration includes a one hour plus break-in period to allow the inlet fluid temperature and outlet

pressure to be increased to the final test conditions shown in **Table 3**. The remainder of the test is conducted in the steady-state mode.

## 7. Pump Testing Procedures

7.1 Although numerous pump tests may be devised, most are based on one, or combinations of two or more, of three testing strategies. These include:

7.1.1 *Cycled Load (Pressure)*—A pump test may be run by cycling between a higher and a lower pressure at a constant volume. This type of test procedure is beneficial because cycling the pressure affects the control system, slipper contact varies, fluids change characteristics under pressure (for example, cavitation, aeration), it evaluates cradle bearing scuffing, it provides acceleration and deceleration of the fluid, it provides case pressure spikes, and it is representative of the “real world.” Deficiencies of cycled pressure tests are that this procedure stresses the bearing and yoke assembly more than the fluid life; cost for a robust stand; and less time at maximum and minimum shear and stress.

7.1.2 *Cycled Volume*—A cycled volume test is conducted by alternating between a minimum and maximum volume per stroke and is conducted at a constant pressure. This type of test influences component life more than providing maximum stress on the fluid to evaluate fluid life properties. The advantages and disadvantages are essentially analogous to those described in 7.1.1.

7.1.3 *Constant Pressure and Constant Volume*—For the greatest stress on the hydraulic fluid, it is recommended that the pump be run at a constant pressure and volume at a maximum temperature. If low-temperature wear is a concern, then a low fluid temperature cycle may need to be included, probably at the beginning of the test. Experience has shown that most wear occurs at the beginning of the test during “break in,” unless the fluid is deficient at the selected operating conditions or reaches the end of its useful life during the test.

7.1.3.1 Advantages of the constant pressure test include: lower cost, simpler test stand; more durable test stand and higher stress on the hydraulic oil (maximum shearing and temperature rise). Variation in the system pressure load will not provide any additional information about the fluid properties. Many people believe that since the pressure inside of the cylinders is fluctuating, there is no need to further complicate the system with additional pressure changes. The primary

**TABLE 3 Steady-State Operating Conditions for the Eaton 35VQ35 Vane Pump Test**

Speed	2400 rpm
Outlet Pressure	207 bar gage
Inlet Pressure	0 to 0.15 bar gage with flooded unit
Inlet Temperature	93°C

disadvantage of the constant pressure test is that this testing procedure is not representative of common “real world” applications.

## 8. Pump Stand Design

8.1 Various pump testing procedures have been reported for use in evaluating components under different operating conditions. Three standards that describe different testing procedures but which are useful references in test design development are: SAE J745, ANSI/(NFPA)T3.9.20 and ANSI/(NFPA)T3.9.33. As indicated in Section 7, there are numerous testing variations that may be selected depending on the objective of the piston pump test being performed. ANSI/JIC T2.24.1 provides basic guidance in the preparation of detailed equipment specifications, and promotes personnel safety, and proper use of hydraulic equipment. The most critical parameters that must be monitored for any test are discussed throughout Section 8.

8.2 *Fluid Residence Time (Reservoir Size)*—The reservoir for the test stand should be of sufficient size to accommodate fluid cooling and air release (7). However, the reservoir should also be sufficiently small to simulate the reservoir of an actual system that would provide a fluid turnover time of 20 s or three times per minute.

NOTE 19—The desired reservoir volume ( $V_R$ ) can be calculated from the flow rate: ( $V/\text{min}$ ) where  $V_R = 3V$ . This simple calculation means that ideally the total volume of the reservoir should turn over at least three (3) times per minute which is a common recommendation used for mobile hydraulic units (8).

NOTE 20—Typically, the reservoir volume in actual hydraulic systems may vary from as small as 1 to 1.5 times the flow rate for mobile systems up to 2 to 4 times the flow rate for industrial stationary systems. It is important that the heat exchanger capacity be sufficient to provide the necessary temperature control of the hydraulic fluid, particularly when smaller reservoirs are used (see 8.4).

8.2.1 Additional recommended reservoir design features include (9):

8.2.1.1 The suction feeds to the hydraulic pump shall be located such that adequate fluid supply to the operating circuit is maintained at the minimum operating fluid level and that air ingress and the formation of vortices in the fluid are eliminated.

8.2.1.2 Return feeds to the reservoir shall be discharged below the operating fluid level.

8.2.1.3 Return feeds to the reservoir shall discharge at the lowest practical velocity and shall promote the desired circulation pattern within the reservoir and shall not promote air entrainment.

8.2.1.4 The reservoir configuration shall be such that contaminants cannot be resuspended in the system fluid.

8.2.2 To facilitate air release of the hydraulic fluid returning to the reservoir before it re-enters the inlet, it is recommended

that proper reservoir baffling be used. There are a number of possible designs; and one design is shown in Fig. 4 (10). It is recommended that reservoir design be reviewed with the pump manufacturer before initiating the test program.

8.2.3 ANSI (NFPA)T3.16.2 provides some useful guidelines for the design, construction, and selection of reservoirs. Also included in this document are descriptions of proper function and maintenance of hydraulic reservoirs.

8.3 *Inlet Piping Requirements (8)*—The suction line into the reservoir for the hydraulic pump must be adequately submerged to prevent vortexing. The following rules from the Lightning Reference Handbook (8) have been offered as guidelines to prevent vortexing:

8.3.1 Design intake lines for the minimum possible velocity, <4 ft/s.

8.3.2 Ensure that the intake line is submerged 1.75 to 2 times the intake line inside diameter.

8.3.3 Use bell-mouthed fittings on intake pipes to reduce intake velocity at point of entry below the pipe velocity.

8.3.4 Ensure that the intake pipe is 5 to 6 times the pipe inside diameter away from the nearest reservoir wall on at least one side.

8.3.5 Ensure that the intake pipe is no closer to the reservoir bottom than the pipe (inside diameter/2).

8.4 *Hydraulic Oil Temperature*—The pump inlet oil temperature should be the maximum allowed by the pump manufacturer or equipment manufacturer. The purpose is to test the thermal and oxidative stability of the fluid which affects deposit formation, corrosion, and filter plugging. This is normally approximately 90 to 95°C for anhydrous fluids. Water-containing fluids must be tested at a lower temperature and the temperature that should be used is that specified for this class of fluids by the hydraulic pump manufacturer.

8.4.1 Both the fluid reservoir temperature (or pump inlet oil temperature) and the case drain oil temperature should be recorded. Typically, the case drain oil temperature is approximately 10 to 20°C higher than the pump inlet temperature.

NOTE 21—The recommended fluid viscosity and viscosity limits for the pump being tested should be obtained from the pump manufacturer. Typically, the recommended maximum oil temperature is that value that provides a fluid viscosity of 8 to 10 cSt. However, testing may be conducted at a higher temperature that provides a fluid viscosity of 6 to 7 cSt. However, if the fluid viscosity is 6 to 7 cSt, a high-performance hydraulic oil with an anti-wear additive system is typically required.

8.5 *Pump Inlet Condition*—If the hydraulic fluid cannot be supplied to the pumping chambers of the pump at a sufficient rate, there is significant danger that the pump will cavitate. The fluid flow versus shaft speed for a typical hydraulic pump will be linear up to the point where the fluid can no longer enter the pumping chambers of the pump as they are opened and closed because of shaft rotation. When this occurs, the chambers will only partially fill and the outlet flow will be reduced. Under these conditions, the pump will be starved for fluid. The speed where this starvation will occur depends on the viscosity and density of the hydraulic fluid as well as the physical configuration of the pump inlet and connecting lines. Therefore, it is necessary to size the inlet piping and to properly position the pump relative to the reservoir such that the inlet pressure to the pump is positive.



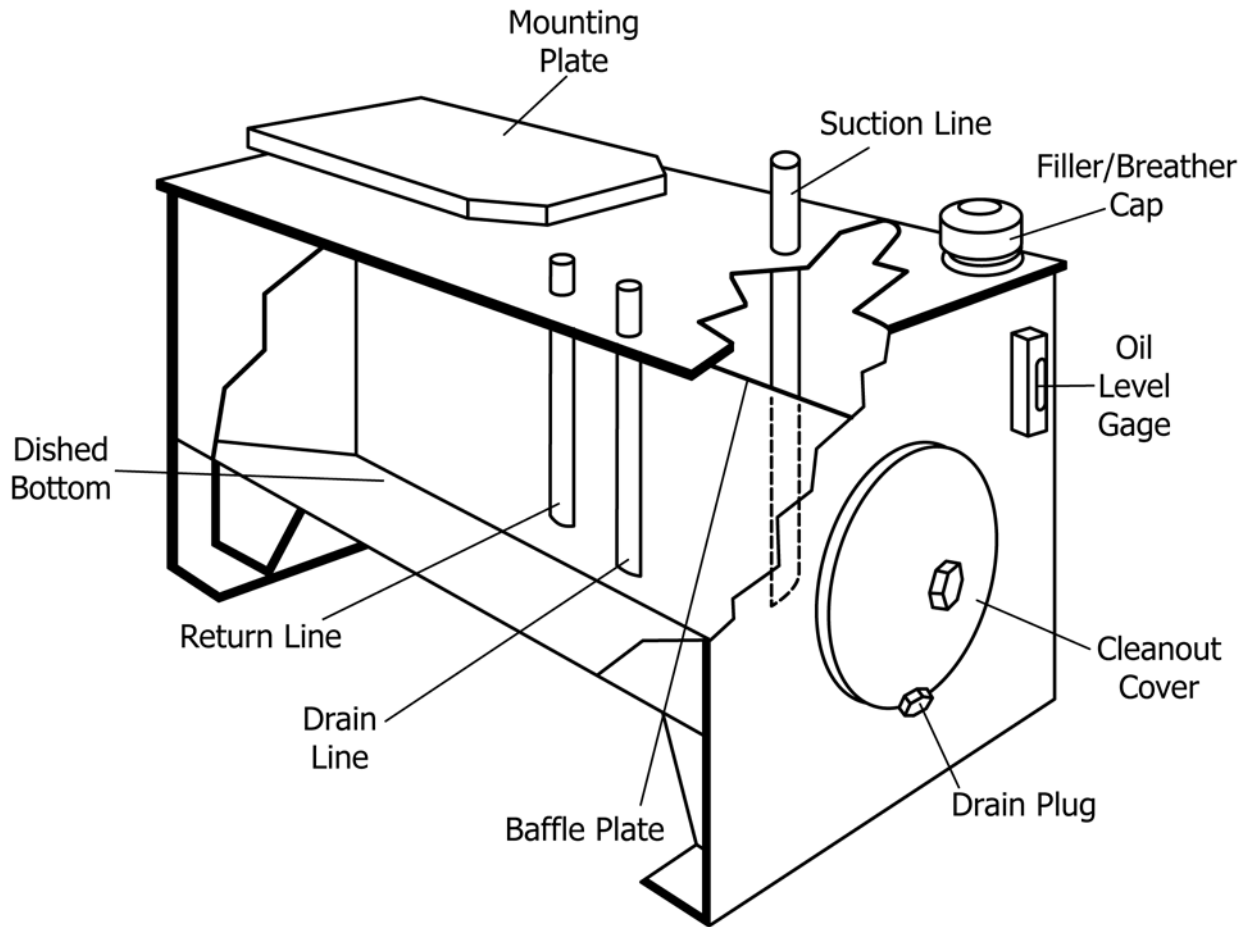

FIG. 4 Illustration of a Reservoir Baffling Design that Has Been Recommended

8.5.1 The pressure at the inlet to the pump is normally called the Net Positive Suction Head (NPSH) and may be calculated in terms of absolute pressure (11). The entire system from the fluid level in the reservoir to the inlet of the pump must be taken into account when determining the NPSH as illustrated in Fig. 5. The primary factors are:

8.5.1.1 The atmospheric head or the atmospheric pressure at the particular location ( $H_A$ ).

8.5.1.2 The friction head or the pressure needed to overcome the losses due to friction when the fluid is flowing through the intake pipe, fittings, valves, and area changes ( $H_F$ ).

8.5.1.3 Static inlet head or vertical distance from the centerline of the pump inlet to the free surface level in the reservoir ( $H_S$ ).

8.5.1.4 The vapor pressure of the fluid at the fluid temperature ( $H_{VP}$ ).

8.5.2 These parameters can be used to calculate the NPSH according to the equation:

$$\text{NPSH} = H_A + H_S - H_F - H_{VP} \quad (9)$$

8.5.2.1 The vapor pressure ( $H_{VP}$ ) that must be used in this calculation is the vapor pressure of the fluid at the inlet (reservoir) temperature. This can be a substantial negative contribution, particularly for water-containing fluids at elevated temperatures.

8.5.2.2 It is important to maintain a positive inlet pressure. However, the actual inlet pressure that must be maintained to prevent cavitation is specific to the piston pump design, and this value should be obtained with respect to the hydraulic test circuit from the pump manufacturer. If insufficient inlet pressure cannot be achieved by repositioning the pump relative to the reservoir, then it may be necessary to “supercharge” the inlet using an auxiliary feed pump.

8.5.2.3 It is also recommended that the suction feed to the operating circuit be sized to limit the pump intake velocity to 1.2 m/s (4 ft/s) (9).

NOTE 22—The auxiliary pump must have a net positive suction head at its inlet also.

8.6 *Intake Line Placement*—Ensure that the inlet pipe is 5 to 6 times the pipe inside diameter from the nearest obstruction. (An obstruction would include: elbow, joint, or any obstruction to flow.) The inlet pipe should not be closer to the reservoir bottom than the inside diameter of the inlet pipe/2.

8.7 *Pump Metallurgy*—The metallurgy of the critical material pairs of the pump being used are important and may affect wear performance. Critical material pairs include: wear plate/shoe interface, port plate/face plate interface, piston/barrel sleeve, cylinder block, pistons, shoes, valve plate, rolling element bearings, shaft seals, and the like.

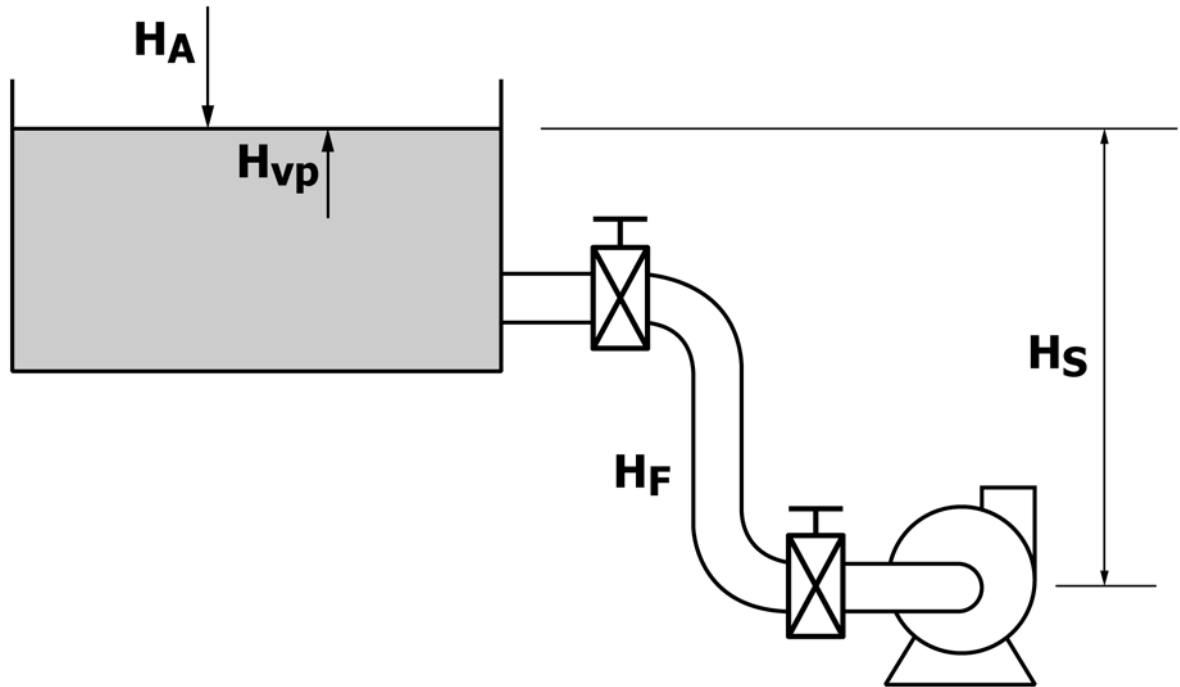

FIG. 5 Illustration of NPSH Parameters

## 9. Fluid Specification Requirements

9.1 *Importance of Viscosity—Temperature Properties*—One of the most important fundamental physical properties of a hydraulic fluid is viscosity. Fluid viscosity affects both operational characteristics of the hydraulic system and the lubrication properties of the fluid.

9.1.1 Maximum and minimum viscosity limits for hydraulic pumps are dependent on pump design and these values are obtainable from the manufacturer of the piston pump being tested. The maximum fluid viscosity that can be used is known as “cold start” viscosity.

9.1.2 The effect of temperature and pressure on the pumpability of a hydraulic fluid must also be considered. There is typically an optimal range for proper operation of a hydraulic pump. For example, at very low temperatures, increased fluid viscosity leads to cavitation, and at excessively high temperatures, insufficient fluid viscosity results in pump slippage and loss of efficiency and also loss of lubrication leading to wear.

9.1.3 Although the pump manufacturer will have a recommended operating fluid viscosity range, there are trade-offs. A higher fluid viscosity grade will exhibit lower oxidative stability, poorer heat transfer, and slower air release, but the lower viscosity grade will stress the anti-wear performance. Both extremes affect cavitation. Therefore, the effects of both temperature and viscosity of a hydraulic fluid on performance must be considered.

9.2 *Contamination Levels*—Hard solid particles, especially those larger than  $10\ \mu$ , cause abrasive wear not only in the hydraulic pump but also within the system components such as valves, and so on, and should be monitored during a pump test. Particle generation is high at the beginning of the pump test and usually declines through the test. At the end of the test,

very low particle concentrations are expected if the system has appropriate filtration. The best way to obtain reliable data is by in-line counting. Off-line bottle sampling is subject to many errors.

9.2.1 Cleanliness requirements are determined by the equipment specifications available from the piston pump supplier. Some recommendations are provided in DIN 51515. It is important to have a good filtration in the test system to provide adequate system cleanliness. System cleanliness requirements will be determined by reviewing the pump manufacturer recommendations. Generally, the filter rating shall include a Beta rating of at least 75 to obtain the appropriate ISO particle count rating.

9.2.2 The hydraulic oil may contain “typical” concentrations of water that shall be determined using Karl Fischer analysis (see 6.3.3). Typically, new, unused mineral-base hydraulic oils contain 0.04 to 0.1 % water (100 to 300 ppm is typical for hydraulic oils which have less than 1 wt % compounding).

## 10. Pump Test Monitoring and Evaluation

10.1 Various operational parameters may be monitored throughout the pump test. These parameters are summarized in 10.1.1 – 10.1.6.

10.1.1 *Vibrational Analysis*—Sources of system noise and vibration may be mechanical or fluid-borne.

10.1.2 *Mechanical Noise*—Sources of mechanical vibrations include vibrating surfaces from pressure fluctuations emanating from pistons, unbalanced rotational vibrations, or vibrating pipe walls. For example, increased vibration of the pump case may indicate wear of the shaft/bearing pair.

10.1.3 *Fluid-Borne Noise*—Liquid motion may produce pressure fluctuations caused by fluid dynamics. Examples of

**TABLE 4 Hydraulic Pump Operating Parameters**

Operation Conditions	Required Data, Measure Before Start of Test	Constant Test Condition (Flow and Pressure), h	Variable Test Condition (Flow and Pressure Profile and Cycles), h <sup>A</sup>	Variable Test Condition, h
Speed, rpm				
Inlet Pressure, bar				
System Pressure, bar				
Reservoir Fluid Temperature, °C				
Leakage Fluid Temperature, °C				
Leakage Flow, L/min (Case Drain)				
Leakage Pressure, bar				
Shaft Power, kW				
Hydraulic Power, kW				
Total Efficiency, %				
Particle contamination, cleanliness class <sup>B</sup>				
Condition Monitoring (Body Noise)				

<sup>A</sup> Profile for flow: 1.5 s from min to max and from max to min, 1.5 s constant min and max flow, 1.5 s from max to min flow, (6 s/cycle, 600 cycles/h), pressure followed in the same way.

<sup>B</sup> Cleanliness class 19/16/13 (ISO 4406) is recommended as a minimum.

fluid dynamic sources of noise and vibration include: turbulence, cavitation, flashing of the hydraulic fluid, and flow separation or vorticity. Pressure and flow pulsations may lead to mechanical vibrations which may radiate acoustic noise. These fluid dynamic sources characteristically lead to unstable flow patterns producing vortices at the boundaries between the high-velocity and low-velocity regions. These vortices are converted to pressure perturbations as they impinge on side-walls which, in turn, result in vibration of the piping or pump housing.

10.1.4 *Pressure Monitoring*—Increased magnitude of the pressure spikes may indicate wear of the valve plate or erosion. Uneven pressure output could reflect wear within the compensator.

10.1.5 *Volumetric Output*—A decrease of the flow would indicate internal wear or change in fluid viscosity. Monitoring case drainage would be a confirmation of this effect. An increase in case drainage flow and temperature would be indicative of internal wear.

10.1.6 *Pump Operating Parameters*—It is recommended that a data log be kept of the hydraulic pump test. **Table 4** provides an illustration of such a log. In addition to the data shown in **Table 4**, information relating to pump derating shall be recorded. Also, note the field history of the hydraulic fluid, which shall include a brief description of years of experience and any known strengths and deficiencies.

## 11. Pump Test Monitoring and Evaluation Criteria

11.1 *Fluid Test Parameters*—Key fluid characterization properties should be measured at the start and end of a test, and some should be monitored at intervals during the test. An example protocol is given in **Table 5**.

11.1.1 As a minimum, the fluid test parameters should include: viscosity (Test Method **D445**), neutralization number (Test Method **D664**), water content (Test Method **D1144** or **E203**), and reserve alkalinity (Test Method **D1121**), if the fluid is a water-containing fluid such as HFB or HFC. Particle count analysis (ISO 11171) should be performed on the used fluid and, if necessary, ferrographic analysis or elemental analysis, or both, to determine the source of any particles (wear or corrosion). Elemental analysis may also be done to monitor

**TABLE 5 Measuring Fluid Properties During a Pump Test**

Property	Test Method	Start of Test	Monitor	End of Test
Viscosity at 40°C	D455	X	X	X
Viscosity at 100°C		X		X
Total Acid Number	<b>D664</b>	X	X	X
Water Content	D1744, <b>D6304</b> or <b>D95</b>	X	X	X
Appearance	Visual	X	X	X
Color	<b>D1500</b>	X		X
Infrared Spectrum		X	X	X
Particle Count	ISO 4406	X	X	X
Metals	<b>D5185</b>	X	X	X
Demulsibility	<b>D1401</b>	X		X
Foaming	<b>D892</b>	X		X
Air Release	<b>D3427</b>	X		X
Oxidation	<b>D2272</b>	X		X
Filterability	NF E48–690	X	X	X
	NF E48–691	X		X
	NF E48–692	X	X	X

additive element depletion or wear metal accumulation. Analysis of metals is typically performed by Test Methods **D5185** or **D6595**. A procedure similar to Test Method **D6376** may be used for analyzing wear particles on a patch with subsequent elemental analysis using X-ray fluorescence spectroscopy.

NOTE 23—The performance of water-containing fluids such as HFB and HFC fluids is dependent on the actual water content. Therefore, it is important to determine the water content not only on the fresh fluid but also on the fluid at the conclusion of the test and at intermediate times, if needed. It is suggested that water content should be maintained at  $\pm 1\%$  of the initial value.

11.1.2 There are three manufacturers of analytical ferrography equipment plus numerous in-house methods using filter-gram techniques (sometimes called patch ferrography). The debris field is analyzed microscopically using an assortment of particle treatment methods (heat, chemicals, impaction, bichromatic light, magnetism, and the like). Some laboratories use image analyzers and particle recognition software. While there are no current ASTM or ISO methods for the optical analysis of wear particles, a standard condition monitoring test procedure, which includes wear particle identification methods, is being developed by ISO TC108/SC5/WG4.

11.1.3 An example of a performance criterion is that a fluid fails if there is a change in viscosity of  $>20\%$  or if an increase

**TABLE 6 Pump Component Wear Rating**

Part Ratings	Photograph and Description of the Type and Degree of Wear Observed
Piston Shoe Face	Land darkening, discoloration, material deformation, scratches, scoring, plastic flow
Swash (Creep) Plate	Scratches, polishing, discoloration, metal transfer, heat checks
Port (Face) Plate	Darkening, abrasive wear, cavitation, cracking, heat checks

in neutralization number of  $\geq 2$  mg KOH/g has occurred. Other parameters such as filterability, color, appearance, foaming tendency, air release time, and loss of oxidation inhibitor may be monitored.

11.2 *Pump Performance Appraisal*—Variation of the pump operating parameters such as input speed, system pressure, system temperature, case temperature, case pressure, and flow, throughout the test is an excellent indicator of wear. A sudden increase in temperature and a sudden drop in flow are good indicators that there are lubricating problems with one or more bearing surfaces. A permanent increase in pressure drop across the downstream filter may indicate plugging due to particles from wear or fluid deterioration.

11.2.1 It is recommended that the condition of internal wear contacts shall be determined and recorded. **Table 6** provides a partial list for illustrative purposes. Each component should be photographed to provide a record of these observations. In the case of bearings and other parts, it may be desirable to determine weight loss during the test. If the pump manufacturer can provide a wear catalog, comparing the appearance of parts to examples in the catalog can aid in determining wear.

11.2.2 At the end of the test, the pump should be disassembled and examined both qualitatively and quantitatively for wear and parts distress. Examples are polishing or scuffing of, or metal transfer to, the swash plate; piston shoe land wear; port plate and face plate corrosion or cavitation wear; darkening or deposits in cylinder bores; radial lip seal wear; and bearing distress.

11.2.3 An example of wear determination would be visual inspection with photography of the degree of smearing that may occur on the valve plate and cylinder block at the conclusion of the test. A “pass/fail” determination would be made by comparing the degree of smearing with a wear catalog provided by the pump manufacturer for the wear surface being examined. The wear catalog would indicate no wear, acceptable and unacceptable levels of wear upon which the final determination is made. Any abnormal wear, scuffing, or adhesive failure is a cause for concern. Other wear surfaces to examine include: shaft bearings, piston block/bore interface, piston/slipper interface, slipper/swash-plate interface, cylinder block/valve plate interface, shaft seal, and other sealing areas.

11.3 *Surface Analysis*—Using visual inspection as the sole means of evaluating surface condition is often insufficient. After testing, surface wear should be analyzed using accurate surface measurement. This may be done using a stylus or laser equipped instrument. Reasonable limits of maximum wear depth in relation to the measured mean particle concentration should be established as a pass/fail guideline.

**TABLE 7 Summary of Komatsu HP35V35 and 35 Piston Pump Test Conditions**

Pressure	10 to 420 kg/cm <sup>2</sup> (140 to 6000 psi)
Oil Flow	16 gal (at 140 psi); 5 gal at (6000 psi)
Speed	2100 rpm
Temperature	80°C
Tank Volume	16 gal
Duration	500 h

## 12. Reference Oil

12.1 The reference oil selected is dependent on the problem to be solved. For example, one may select a hydraulic fluid composition to improve upon its performance level. Alternatively, one may select an oil with minimum acceptable performance.

## 13. Illustrative Pump Manufacturers Piston Pump Tests

13.1 There are numerous piston pump test procedures to assess the lubricating properties of a hydraulic fluid. Most of these tests have been developed and used by various pump manufacturers. However, at the present time there is no national standard piston pump test. This section provides an overview of a number of piston pump tests that have been developed by equipment manufacturers to evaluate certain features of their pumps. These tests apply many of the ideas discussed in Sections 7, 8, 10, and 11. These tests are generally performed as fluid qualification tests for pumps manufactured by the specific pump producer.

13.2 *Komatsu HPV35+35 Piston Pump Test*—Recently, Komatsu developed a piston pump test to evaluate biodegradable vegetable oil-based hydraulic fluids (**12**). This test is based on a Komatsu HPV35+35 dual-piston pump using cycled pressure test conditions summarized in **Table 7** and shown schematically in **Fig. 6**. The test evaluation criteria are pump efficiency change, wear and surface roughness, formation of lacquer and varnish, and hydraulic oil deterioration.

13.3 *Rexroth Piston Pump Test*—Rexroth has proposed a three-stage piston pump test based on the Brueninghaus A4VSO 125 piston pump (**13**). Stage one is conducted at maximum operating pressure, displacement, and temperature and at the minimum viscosity specified for the fluid being tested. The test duration is 250 h at which time the pump is dismantled and inspected. The second stage of the test is a pulsed pressure test at the maximum displacement of the pump. This stage is operated for one million cycles. When this stage is complete, the pump is dismantled and inspected. The third stage is a variable displacement stage at maximum pressure, maximum temperature, and minimum fluid viscosity. The test duration is one million cycles (at approximately 2 Hz) at which time the pump is dismantled and inspected again. These test conditions are summarized in **Table 8**. The final pass/fail assessment is made with reference to a standard damage catalog provided by Rexroth.

13.4 *Sundstrand Water Stability Test Procedure*—This test was originally conducted using a Sundstrand Series 22 piston pump at a constant pressure (**14**). Currently this test procedure

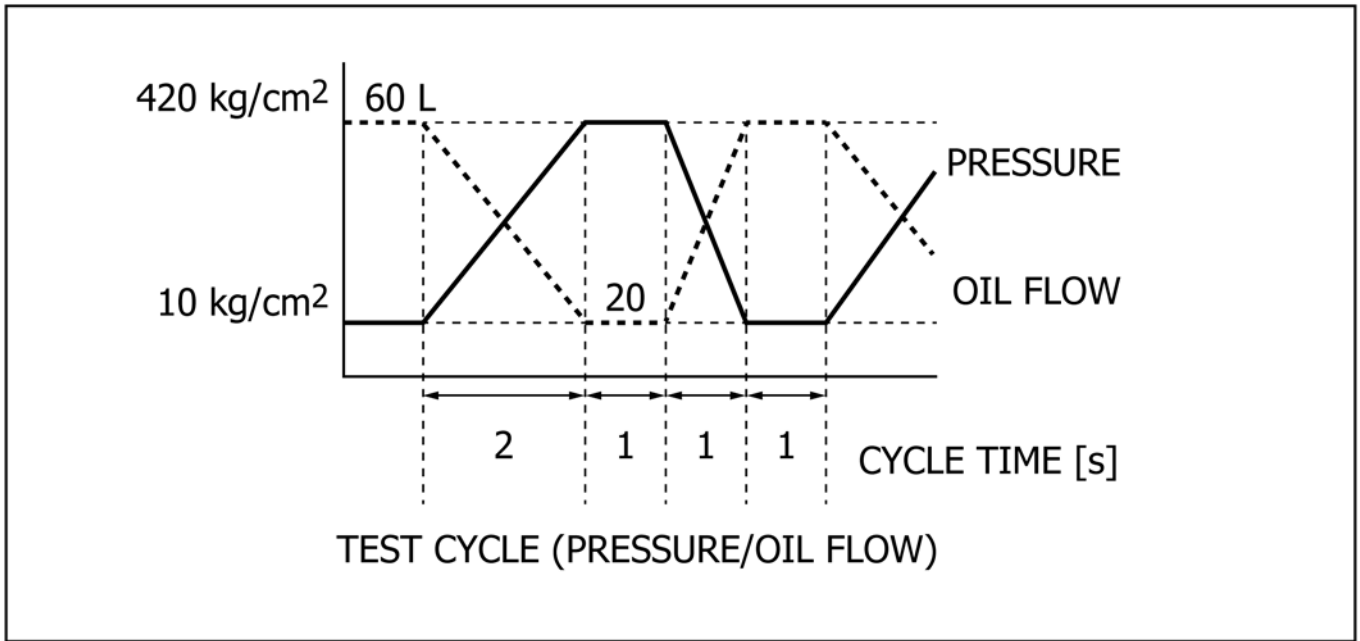

FIG. 6 Schematic Illustration of the Test Sequence Used for the Komatsu HP35V35 + 35 Piston Pump Test

TABLE 8 Summary of the Rexroth Brueninghaus A4VSO 125 Piston Pump Test Conditions

Stage 1—Continuous Load Operation	
Running Conditions	Maximum operating pressure, maximum fluid temperature, minimum fluid viscosity specified for fluid class
Total Time/Stage 1	250 h; pump is dismantled and inspected
Stage 2—Pulsed Pressure Operation at Maximum Displacement	
Running Conditions	Load pressure—0-maximum, maximum fluid temperature, minimum fluid viscosity specified for fluid class
Total Time/Stage 2	1 million cycles, 2 to 3 Hz, 100 to 150 h; pump is dismantled and inspected
Stage 3—Variable Displacement at Maximum Pressure	
Running Conditions	Maximum pressure, maximum fluid temperature, minimum fluid viscosity specified for fluid class
Total Time/Stage 3	1 million cycles, 1 s/cycle, total time is 280 h at which point the pump is dismantled and inspected

TABLE 9 Summary of the Sundstrand Piston Pump Water Stability Test Procedure

Input Speed	3000 to 3200 rpm
Load Pressure	5000 psi (344 bar)
Charge Pressure	180 to 220 psi (12.4 to 15.2 bar)
Case Pressure	40 psi (2.8 bar) max
Stroke	Full
Reservoir Temperature	150 ± 10°F ( 65 ± 4°C)
Loop Temperature	180 ± 10°F ( 82 ± 4°C)
Maximum Inlet Vacuum	5 in. Hg

is conducted using a Sundstrand Series 90 piston pump with a 55 cm<sup>3</sup> displacement (15). The objective of the test is to determine the effect of water contamination (1 %) on mineral oil hydraulic performance and yellow metal corrosion. However, other fluids, including water-containing fluids such as HFB and HFC fluids and biodegradable fluids, may also be evaluated using this test. The test conditions are summarized in Table 9. The test duration is 225 h at which time it is disassembled and inspected for wear, corrosion and cavitation. If the flow degradation is equal to or greater than 10 %, the test is considered to fail.

13.5 Eaton PVH57C Piston Pump Test Procedure (16)— This test procedure is used to evaluate hydraulic fluids for use

in axial piston pumps. The pump used for this test is the Eaton PVH57 piston pump equipped with a pressure compensator with load sensing control. It consists of an actual test duration time of 250 h, not including break-in or performance running. The operation temperature is dependant on the capability of the test fluid at the specified temperature, whichever is lower. For anti-wear petroleum oils, the required running conditions are speed—2400 rpm, pressure—250 bar (3625 psi), temperature—93°C, and rated inlet pressure—atmospheric pressure. Hydraulic pumps are typically derated for use with non-petroleum oil-based fluids. The Eaton PVH57 hydraulic piston pump is also derated for use with non-petroleum oil-based hydraulic fluids and the recommended test conditions for non-petroleum-based fluids are summarized in Table 10. The rated inlet pressure for non-petroleum-based hydraulic fluids is also equal to atmospheric pressure.

NOTE 24—The recommended derated test conditions shown in Table 10 for the Eaton PVH57 hydraulic piston pump do not necessarily apply to other Eaton hydraulic pumps nor do they necessarily apply to hydraulic pumps available from other manufacturers. The data in Table 10 is offered as an illustration of hydraulic pump derating that may be encountered for non-petroleum-based hydraulic fluids.

13.5.1 The Eaton PVH57C piston pump test is conducted using the recommended speed, pressure, and temperature provided in Table 10 while monitoring input torque, output

**TABLE 10 Eaton PVH57 Specification Fluid Testing Conditions**

Fluid	Rated Speed, rpm	Rated Pressure, max, bar/psig	Rated Temperature, °C/°F
Water Glycol (HFC)	1800	170/2465	50/122
Invert Emulsion (HFB)	1500	155/2247	50/122
90-10 HWBF Thickened (HFAS)	1500	155/2247	50/122
Phosphate Ester (HFDR)	1800	230/3335	65/149
Polyol Ester (HFDU)	1800	230/3335	65/149
Environmentally Friendly—Vegetable Base—(HETG)	1800	250/3625	65/149
Environmentally Friendly—Synthetic Base—(HEES)	2400	250/3625	65/203
Anti-wear Petroleum Oil	2400	250/3625	93/199

pressure, output flow, case flow, case temperature, case pressure, inlet temperature, and SAE Derived Capacity (according to SAE J745) throughout the following procedure:

13.5.1.1 Run a “performance” test as summarized in **Table 11**.

13.5.1.2 Run for 50 h at the rated pressure, speed, and temperature. Spot check performance at 2400 rpm, 120°F (49°C) flooded inlet, and rated pressure—20 bar.

13.5.1.3 Disassemble pump and visually inspect to determine pass/fail (see **13.5.2** for pass/fail criteria). Reassemble the pump.

13.5.1.4 Spot check performance at 2400 rpm, 120°F (49°C), flooded inlet, and rated pressure—20 bar. Then run the following cycling test for 200 h:

- (1) 0.75 s full flow at 90 % rated pressure;
- (2) 0.5 s at rated pressure; and
- (3) 0.5 s at low pressure standby.

13.5.1.5 Disassemble pump after approximately 48 h of cyclic endurance. If hardware is visually acceptable, then reassemble pump, spot check performance and continue the cyclic test as described in **13.5.1.4**.

13.5.1.6 Run the performance test as summarized in **Table 11**.

13.5.1.7 Disassemble and inspect. The pass/fail criteria are provided in **13.5.2**.

13.5.2 *Summary of Pass/Fail Criteria for the Eaton PVH57C Piston Pump after Testing*—The Eaton PVH57C

**TABLE 11 Summary of the Eaton PVH57C Piston Pump “Performance” Test Procedure**

Conditions	See <b>Table 10</b>
Pressure (bar)	70, 140, (210 <sup>A</sup> ), Rated Pressure—20, Rated Pressure
Speed (rpm)	1200, (1800 <sup>A</sup> ), Rated Speed
Temperature	Rated temperature or fluid manufacturers temperature (whichever is lower)

<sup>A</sup> These are the conditions that are permissible for use with a petroleum oil.

piston pump will be disassembled at the indicated times during the test and inspected for:

13.5.2.1 Valve plate running face—finish and visual inspection.

13.5.2.2 Cylinder block running face—finish and visual inspection.

13.5.2.3 Yoke running face—finish and visual inspection.

13.5.2.4 Yoke bearing journals—finish and visual inspection.

13.5.2.5 Saddle bearings—finish and visual inspection.

13.5.2.6 Identify pistons for reassembly into same bore and measure piston/shoe endplay and piston diameter at top, middle and bottom.

13.5.2.7 All piston bores measured at top, middle and bottom.

13.5.2.8 Measure metering land diameters and width on both control spools

13.5.2.9 Photograph visually worn parts.

13.5.3 After these measurements are taken, the pass/fail criteria are:

13.5.3.1 Visual fail if there is material transfer or a coarser surface finish, or both, is observed resulting from abnormal wear.

13.5.3.2 Shoe endplay acceptance criterion is a change of less than 0.05 mm.

13.5.3.3 Overall maximum efficiency loss of 3 %.

13.5.3.4 Maximum variation in full flow of 2 %.

## 14. Keywords

14.1 hydraulic fluid; hydraulic pump testing; piston pump

## REFERENCES

- (1) Lemberger, S., and Totten, G. E., “Chapter 12—Failure Analysis,” *Handbook of Hydraulic Fluid Technology*, Ed. G. E. Totten, Marcel Dekker Inc., New York, NY, 2000, pp. 601-673.
- (2) *Fire Resistance of Industrial Fluids, STP 1284*, Eds. G. E. Totten and J. Reichel, ASTM International, W. Conshohocken, PA, 1996.
- (3) CFR—Part 35, “Fire Resistant Fluids,” U.S. Mine Safety and Health Administration.
- (4) “Approval Standard: Less Hazardous Hydraulic Fluid—Class Number 6930,” Factory Mutual Research Corporation, Norwood, MA, Feb. 7, 1975.
- (5) Johnson, H. T., and Lewis, T. I., “Vickers 35VQ25 Pump Test,” *Tribology of Hydraulic Pump Testing, ASTM STP 1310*, Eds. G. E. Totten, G. H. Kling, and D. J. Smolenski, ASTM International, W. Conshohocken, PA, 1996, pp. 129-139.
- (6) “Pump Testing Performance for Evaluation of Antiwear Fluids for Mobile Applications,” Vickers Form No. M-2952-S, Eaton Corporation, Eaton Hydraulics, Eden Prairie, MN.
- (7) Bishop, R. J., and Totten, G. E., “Managing Foam and Aeration in Hydraulic Fluids,” *Proceedings of the International Conference and Exhibition, Practicing Oil Analysis 2000*, Tulsa, OK, October 24-26, 2000, pp. 58-70.
- (8) *Fluid Power Designer’s Lightning® Reference Handbook*, 8th Edition, Paul-Munroe Rucker, Inc., Whittier, CA, 1994, p. 118.
- (9) *Fluid Power Designer’s Lightning® Reference Handbook*, 8th Edition, Paul-Munroe Rucker, Inc., Whittier, CA, 1994, p. 17.
- (10) “Lesson 13—Hydraulic Fluid Conditioning,” *Fluid Power*

*Basics—An Introduction to Hydraulics and Pneumatics*, Bulletin 0239-B1, Parker Hannafin Corporation, Motion & Control Group, Training Dept., Cleveland, OH, 1993, p. 13-1.

- (11) Tessmann, R. K., Melief, H. M., and Bishop, R. J., “Chapter 1—Basic Hydraulic Pump and Circuit Design,” *Handbook of Hydraulic Fluid Technology*, Ed. G. E. Totten, Marcel Dekker Inc., New York, NY, 2000, pp. 1-64.
- (12) Ohkawa, S., Konishi, A., Hatano, H., Ishihama, K., Tanaka, K., and Iwamura, M., “Oxidation and Corrosion Characteristics of Vegetable-Base Biodegradable Hydraulic Oil,” SAE Technical Paper Series, Paper Number 951038, 1995.
- (13) Melief, H. M., Totten, G. E., and Bishop, R. J., “Overview of the Proposed Rexroth High-Pressure Piston Pump Testing Procedure for Hydraulic Fluid Qualification,” SAE Technical Paper Series, Paper Number 982022, 1998.
- (14) “Sundstrand Water Stability Test Procedure,” Sundstrand Bulletin No. 9658, Sauer-Danfoss Corp., Ames, IA.
- (15) “The Effect of Water-Contaminated Hydraulic Fluid on the Sauer-Sundstrand 90 Series Axial Piston Pump,” Specification Number JDQ 84, John Deere Corporation, Waterloo, IA.
- (16) Eaton Engineering Standard ATS-362, “Eaton PVH57C—Test Procedure for Evaluation of Fluids for Open Loop Axial Piston Pumps,” Eaton Corporation, Hydraulics Division, Eden Prairie, MN.
- (17) McHugh, P., Stofey, W. D., and Totten, G. E., “Chapter 14—Mineral Oil Hydraulic Fluids,” *Handbook of Hydraulic Fluid Technology*, Ed. G. E. Totten, Marcel Dekker Inc., New York, NY, 2000 , pp. 711-794.

*ASTM International takes no position respecting the validity of any patent rights asserted in connection with any item mentioned in this standard. Users of this standard are expressly advised that determination of the validity of any such patent rights, and the risk of infringement of such rights, are entirely their own responsibility.*

*This standard is subject to revision at any time by the responsible technical committee and must be reviewed every five years and if not revised, either reapproved or withdrawn. Your comments are invited either for revision of this standard or for additional standards and should be addressed to ASTM International Headquarters. Your comments will receive careful consideration at a meeting of the responsible technical committee, which you may attend. If you feel that your comments have not received a fair hearing you should make your views known to the ASTM Committee on Standards, at the address shown below.*

*This standard is copyrighted by ASTM International, 100 Barr Harbor Drive, PO Box C700, West Conshohocken, PA 19428-2959, United States. Individual reprints (single or multiple copies) of this standard may be obtained by contacting ASTM at the above address or at 610-832-9585 (phone), 610-832-9555 (fax), or [service@astm.org](mailto:service@astm.org) (e-mail); or through the ASTM website ([www.astm.org](http://www.astm.org)). Permission rights to photocopy the standard may also be secured from the Copyright Clearance Center, 222 Rosewood Drive, Danvers, MA 01923, Tel: (978) 646-2600; <http://www.copyright.com/>*