



# Standard Test Method for Operating Performance of Continuous Electrodeionization Systems on Reverse Osmosis Permeates from 2 to 100 $\mu\text{S}/\text{cm}^1$

This standard is issued under the fixed designation D6807; the number immediately following the designation indicates the year of original adoption or, in the case of revision, the year of last revision. A number in parentheses indicates the year of last reapproval. A superscript epsilon ( $\epsilon$ ) indicates an editorial change since the last revision or reapproval.

## 1. Scope

1.1 This test method covers the determination of the operating characteristics of continuous electrodeionization (CEDI) devices, indicative of deionization performance when a device is applied to production of highly deionized water from the product water of a reverse osmosis system. This test method is a procedure applicable to feed waters containing carbonic acid and/or dissolved silica and other solutes, with a conductivity range of approximately 2 to 100 microsiemens- $\text{cm}^{-1}$ .

1.2 This test method covers the determination of operating characteristics under standard test conditions of CEDI devices where the electrically active transfer media therein is predominantly regenerated.

1.3 The test method is not necessarily indicative of:

1.3.1 Long term performance on feed waters containing foulants and/or sparingly soluble solutes;

1.3.2 Performance on feeds of brackish water, sea water, or other high salinity feeds;

1.3.3 Performance on synthetic industrial feed solutions, pharmaceuticals, or process solutions of foods and beverages; or,

1.3.4 Performance on feed waters less than 2  $\mu\text{S}/\text{cm}$ , particularly performance relating to organic solutes, colloidal or particulate matter, or biological or microbial matter.

1.4 The test method, subject to the limitations described, can be applied as either an aid to predict expected deionization performance for a given feed water quality, or as a method to determine whether performance of a given device has changed over some period of time. It is ultimately, however, the user's responsibility to ensure the validity of the test method for their specific applications.

1.5 The values stated in SI units are to be regarded as standard. No other units of measurement are included in this standard.

<sup>1</sup> This test method is under the jurisdiction of ASTM Committee D19 on Water and is the direct responsibility of Subcommittee D19.08 on Membranes and Ion Exchange Materials.

Current edition approved May 1, 2009. Published June 2009. Originally approved in 2002. Last previous edition approved in 2002 as D6807 – 02. DOI: 10.1520/D6807-02R09.

1.6 *This standard may involve hazardous materials, operations, and equipment. This standard does not purport to address all of the safety concerns, if any, associated with its use. It is the responsibility of the user of this standard to establish appropriate safety and health practices and determine the applicability of regulatory limitations prior to use.*

## 2. Referenced Documents

2.1 *ASTM Standards:*<sup>2</sup>

D513 Test Methods for Total and Dissolved Carbon Dioxide in Water

D859 Test Method for Silica in Water

D1125 Test Methods for Electrical Conductivity and Resistivity of Water

D1129 Terminology Relating to Water

D1293 Test Methods for pH of Water

D2777 Practice for Determination of Precision and Bias of Applicable Test Methods of Committee D19 on Water

D4194 Test Methods for Operating Characteristics of Reverse Osmosis and Nanofiltration Devices

## 3. Terminology

3.1 *Definitions*—For definitions of general terms used in these test methods, refer to Terminology D1129.

3.2 For descriptions of terms relating to reverse osmosis, refer to Test Methods D4194.

3.3 *Definitions of Terms Specific to This Standard:*

3.3.1 *cell*—an independently fed chamber formed by two adjacent ion exchange membranes, or by a membrane and an adjacent electrode.

3.3.2 *continuous electrodeionization (CEDI) device*—a device that removes ionized and ionizable species from liquids using electrically active media and using an electrical potential to influence ion transport, where the ionic transport properties of the active media are a primary sizing parameter. CEDI

<sup>2</sup> For referenced ASTM standards, visit the ASTM website, www.astm.org, or contact ASTM Customer Service at service@astm.org. For *Annual Book of ASTM Standards* volume information, refer to the standard's Document Summary page on the ASTM website.

devices typically comprise semi-permeable ion exchange membranes and permanently charged ion exchange media. Examples include continuous deionization, electrodiuresis, and packed-bed or filled-cell electro dialysis.

3.3.3 *current efficiency*—the ratio, expressed in percent, of the net transfer of ionized and ionizable solutes per unit cell within a CEDI device, expressed in chemical equivalents transferred per unit time, to the number of coulombs transferred from an external DC power source to each electrode pair, expressed in faradays per unit time. Calculation of current efficiency is described in 9.2.

#### 4. Summary of Test Method

4.1 This test method is used to determine performance capabilities of CEDI devices with regard to extent of ion removal, pressure/flow relationships and electrical power consumption at standard or nominal operating conditions, electrical current characteristics, and the relative ability of the device to remove ionized and ionizable species when fed reverse osmosis permeate water. On this type of feed, there is considerable water splitting and ion-exchange resin regeneration, causing certain species to become ionized within the device, either by the electromotive force or a localized pH shift. The method is applicable to both new and used devices.

4.2 Pressure loss data is obtained. This information provides information relating to possible particulate plugging, fouling, or internal damage of the device. Deionization performance, extent of silica and dissolved carbon dioxide removal, concentrating stream pH, and applied voltage are determined at a predetermined level of electrical current transfer. The ohmic (electrical) resistance is determined. This information in combination with concentrating stream pH provides basic design and performance information.

#### 5. Significance and Use

5.1 CEDI devices can be used to produce deionized water from feeds of pretreated water. This test method permits the measurement of key performance capabilities of CEDI devices using a standard set of conditions. The data obtained can be analyzed to provide information on whether changes may have occurred in operating characteristics of the device independently of any variability in feed water characteristics or operating conditions. Under specific circumstances, the method may also provide sufficient information for plant design.

#### 6. Apparatus

##### 6.1 Description:

6.1.1 The test apparatus is schematically represented in Fig. 1. Feed water to the apparatus may be passed through a heat exchanger and/or other accessories to modify and/or control feed water temperature as desired. Alternately, data obtained from the operation of the apparatus may be normalized for temperature if normalization factors are known.

6.1.2 Feed water to the apparatus enters a holding tank (open or vented) of volume sufficient to maintain good control of water level and solute concentrations. The tank is unpressurized, ported to be capable of occasional cleanings or sanitizations, and incorporates needed safety features such as

high temperature and overflow protection. The tank also incorporates a drain valve. During operation of the apparatus, the drain valve may be used in combination with a valve controlling the rate of feed water to the apparatus to aid in control of solute concentrations, water level, and temperature within the tank. The tank supplies water to a recirculation pump designed to feed water to the CEDI device at a flow rate and pressure consistent with the ratings of the CEDI device. A recirculation line with shut off valve from the pump discharge to the tank may be incorporated as required for proper pump operation.

6.1.3 Adjustment of feed water solute concentration is not required. Adjust feed water pH as required by the manufacturer of the CEDI device. Feed water to the CEDI device must be monitored for solute concentrations, pH (Test Method D1293), and temperature. Solute concentration may be monitored via electrical conductivity or resistivity (Test Method D1125) in combination with silica (Test Method D513) and carbon dioxide (Test Method D859) concentration measurement, or alternately may be monitored for individual ionic species and dissolved carbon dioxide and silica, depending on the feed water supplied to the tank and the solutes of interest.

6.1.4 Feed water provided to the CEDI device should be plumbed as specified by the supplier, with appropriate flow and pressure controls, internal recirculations, drains, interlocks, safety controls, and other features as required. Pressure at the inlet and outlet and flow rates of each the streams of interest must be monitored (for example, deionized water stream, concentrate stream, and electrode feed stream).

6.1.5 The CEDI device should be powered as specified by the supplier, with equipment and wiring to provide appropriate supply DC voltage and amperage, controls, interlocks, grounding, and safety features. Supply voltage and supply amperage to the CEDI device should be monitored at positions within the device or device assembly as specified by the supplier.

6.1.6 Streams leaving the CEDI device may be returned to the tank via return lines. Alternately, one or more of the streams may be sent either completely or partially to drain via appropriate valving if such operation provides easier control of desired feed water conditions. The outlet deionization stream is monitored for the same solutes as for the feed water. The outlet concentrating stream is also monitored for the same solutes as for the feed water. Control of temperature is not required. For CEDI devices with internal recirculation and “feed and bleed” features, solute concentrations must be measured at locations that are indicative of conditions within the CEDI module prior to mixing of recirculation flows.

6.1.7 Feed water to the tank of the test apparatus shall be prepared using reverse osmosis apparatus. The pretreatment requirements for the RO are optional depending on the application, but should, at minimum, conform to the manufacturer’s specifications for the particular system.

##### 6.2 Installation:

6.2.1 Materials of construction shall be as specified by the supplier of the CEDI device and in conformance to standard engineering practice.

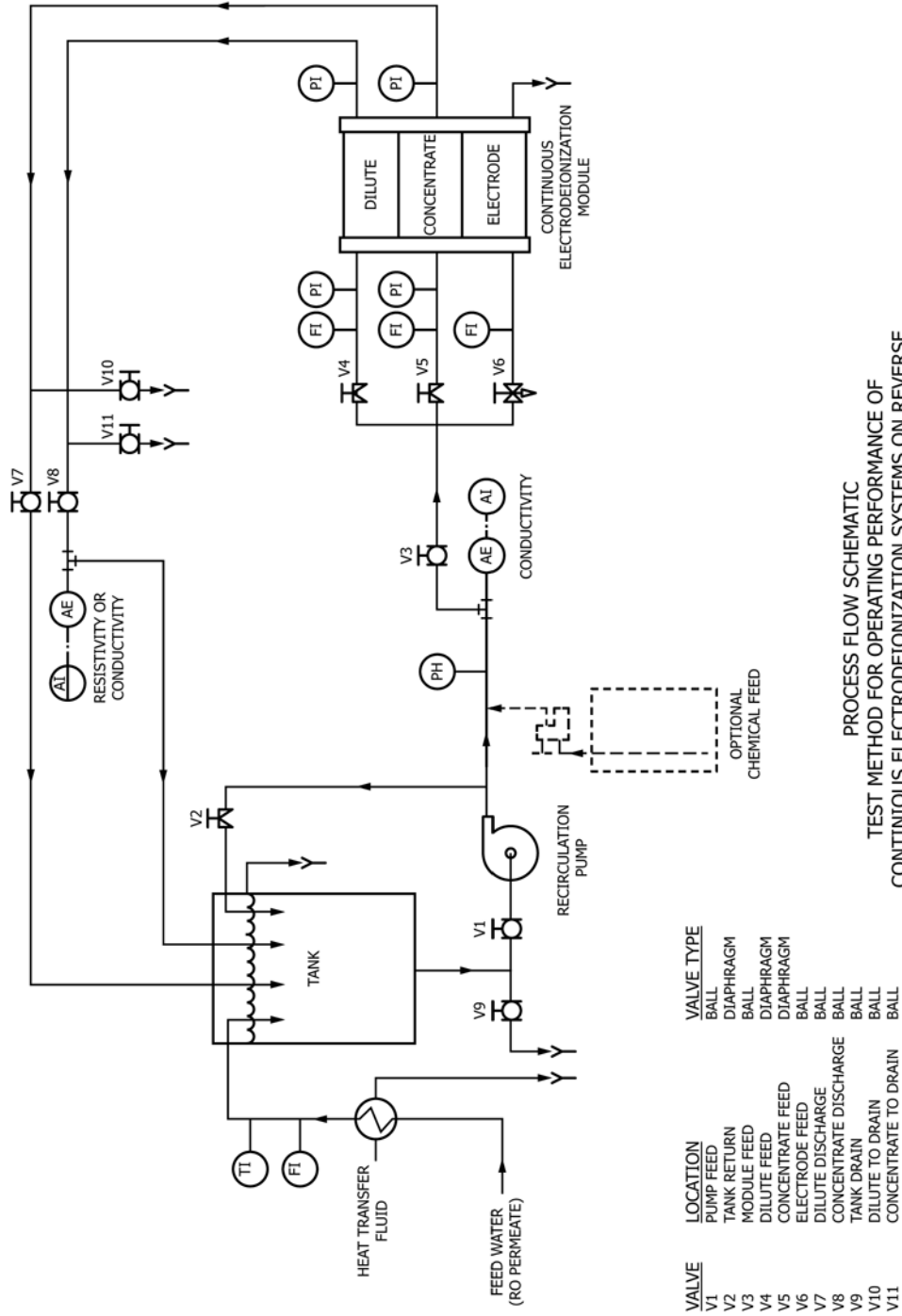

PROCESS FLOW SCHEMATIC  
 TEST METHOD FOR OPERATING PERFORMANCE OF  
 CONTINUOUS ELECTRODEIONIZATION SYSTEMS ON REVERSE  
 OSMOSIS PERMEATES FROM 2-100 uS/CM.

FIG. 1 Process Flow Schematic

ASTM-2 REV.2

VALVE	LOCATION	VALVE TYPE
V1	PUMP FEED	BALL
V2	TANK RETURN	DIAPHRAGM
V3	MODULE FEED	BALL
V4	DILUTE FEED	DIAPHRAGM
V5	CONCENTRATE FEED	DIAPHRAGM
V6	ELECTRODE FEED	BALL
V7	DILUTE DISCHARGE	BALL
V8	CONCENTRATE DISCHARGE	BALL
V9	TANK DRAIN	BALL
V10	DILUTE TO DRAIN	BALL
V11	CONCENTRATE TO DRAIN	BALL

6.2.2 Controls and monitors should be calibrated and maintained according with suppliers requirements and standard engineering practice.

## 7. Reagents

7.1 Specific chemical reagents are not required for this test method. However, chemical modification such as pH adjustment, addition of trace solutes, and the addition of dissolved carbon dioxide may be applicable under certain circumstances. Unless otherwise indicated, it is intended that all reagents shall conform to the specifications of the Committee on Analytical Reagents of the American Chemical Society, where such specifications are available.<sup>3</sup> Other grades may be used, provided it is first ascertained that the reagent is of sufficiently high purity to permit its use without lessening the accuracy of the determination.

## 8. Procedure

### 8.1 Start Up:

8.1.1 Ensure that the tank and reagent feed reservoirs are sufficiently full, with adequate feed water rate to accommodate any losses of water caused by the positioning of the various drain valves. Control valves to the CEDI device should be closed and the device should be unpowered.

8.1.2 Turn on the recirculation pump and then slowly open the feed water throttling valves and various valves and recirculation devices on the CEDI device until the device is operating at nominal or supplier recommended flow conditions. Modify throttling valves to adjust inlet and outlet pressures of the various device streams in accordance with supplier recommendations.

8.1.3 Operate the system with no DC power applied for a sufficient time to ensure adequate removal of any residual air from the piping and device. During this time, flows, pressures, feed solute concentrations, and temperature, should be adjusted until a desirable steady state device feed water condition has been attained.

### 8.2 Electrical Property and Deionization Performance Measurements:

8.2.1 Turn on the DC power supply to the CEDI device, beginning at a low voltage. Raise the applied DC voltage until DC amperage between electrode pairs attains a pre-determined electrical current efficiency, typically below 20 %, but do not apply a voltage or amperage that exceeds supplier's recommendations (consult supplier for recommended values). Current efficiency should be calculated as described in 9.2 using as  $N_d$  the total combined normality of all ionized and ionizable constituents (for example, including all ionized species, and dissolved carbon dioxide as monovalent bicarbonate ion and dissolved silica as monovalent bisilicate ion).

8.2.2 As the internal media electroregenerates, pH shifts and non-steady state concentrate concentrations should be expected. Therefore, recirculation flows, flows to drain, and

voltage should be controlled so as to avoid exceeding supplier's recommended operating parameters and to speed the attainment of steady state conditions.

8.2.3 Continue to operate until steady state is achieved, including applied voltage, concentrate stream electrical conductivity, deionization performance, silica and carbon dioxide concentrations at the deionizing and concentrating stream outlets, and deionizing and concentrating stream flows and inlet and outlet pressures. Since electroregeneration of the active media can be a gradual process, it will typically take 4 to 8 h to reach steady state. Pressures should be expected to change as the internal media electroregenerates. Do not exceed supplier's specifications for pressure differentials.

8.2.4 Measure and record DC voltage, DC amperage, device feed water temperature, deionizing stream inlet and outlet conductivity or resistivity, and deionizing stream flow rate. Also, measure and record feed pH, feed and deionizing stream and concentrating stream outlet silica and carbon dioxide concentrations. Attachment A is a sample test data sheet.

NOTE 1—In RO permeates, dissolved CO<sub>2</sub> often comprises the majority of ionized and ionizable material present, and the CO<sub>2</sub> concentration can vary greatly depending upon the pH of the RO feed water. Since it may not be practical to control the CO<sub>2</sub> concentration feeding the CEDI device, it is very important that the feed CO<sub>2</sub> be measured when this test is performed.

8.3 Pressure Drop Measurements—Once steady state is achieved, as described in 8.2, measure and record pressures of the various inlet and outlet streams of the device. If necessary, normalize pressure differentials for temperature and compare to supplier's specifications.

8.4 Shut Down Procedure—The CEDI system should be shut down in accordance with the manufacturer's recommendations. If no specific recommendations are given the following procedure should be suitable. Turn off applied DC voltage. For shutdown periods longer than 2 weeks, it is recommended that the active media in the device be returned to the exhausted form. This can be done by continuing to operate with the DC power off until feed, deionized, and concentrating stream outlet solute concentrations are approximately equal, or by flushing with a 5 to 10 % sodium chloride solution (this step is optional). Close valves for feed water to the CEDI device. Shut off any pH control or other metering equipment. Turn off the test stand recirculation pump.

## 9. Calculations

9.1 Pressure Drop—Calculate and record pressure drop in the deionizing stream and concentrating stream respectively by subtracting deionizing stream outlet pressure from deionizing stream feed pressure and subtracting concentrating stream outlet pressure from concentrating stream feed pressure. Calculate and record intermembrane pressure drop at the inlets and outlets respectively by subtracting concentrating stream inlet pressure from deionizing stream inlet pressure and by subtracting concentrating stream outlet pressure from deionizing stream outlet pressure. Pressure drop calculations can be normalized for temperature if such a correlation has been developed.

<sup>3</sup> For suggestions on the testing of reagents not listed by the American Chemical Society, see Anal. Standards for Laboratory Chemicals, BDH Ltd., Poole, Dorset, U.K., and the United States Pharmacopeia and National Formulary, U.S. Pharmacopeial Convention, Inc. (USPC), Rockville, MD.

9.2 *Electrical Properties*—Calculate and record electrical current efficiency (the ratio of chemical equivalents of deionization to the electrical equivalents of current passed) as follows:

$$\eta = \frac{Q_d \cdot (N_{d(in)} - N_{d(out)}) \cdot 160\,800}{n_{cp} \cdot I} \quad (1)$$

where:

- $\eta$  = current efficiency, %,
- $Q_d$  = deionizing stream flow rate between a given electrode pair, L/min,
- $N_{d(in)}$  = combined ionized and ionizable concentration of all species present in the deionizing stream inlet, chemical equivalents/L,
- $N_{d(out)}$  = combined ionized and ionizable concentration of all species present in the deionizing stream outlet, chemical equivalents/L,
- $n_{cp}$  = number of independently fed diluting cells between electrodes within the device, and
- $I$  = amperage passed between the electrodes, A.

$N_{d(in)}$  and  $N_{d(out)}$  can be determined via direct analysis or titration, or by suitable correlation with electrical resistivity or conductivity.

9.2.1 Calculate and record ohmic resistance in ohms by dividing voltage by the amperage between a given electrode pair. Voltage or ohmic resistance can be normalized for temperature if such a correlation has been developed.

9.3 *Deionization Performance*—For each ionized or ionizable species being monitored calculate the percent removal as follows:

$$R = \frac{C_{d(in)} - C_{d(out)}}{C_{d(in)}} \times 100 \quad (2)$$

where:

- $R$  = percent removal, %,

- $C_{d(in)}$  = deionizing stream inlet concentration of a particular species (for example, silica or carbon dioxide), and
- $C_{d(out)}$  = deionizing stream outlet concentration of a particular species.

## 10. Precision and Bias

10.1 Single-operator precision and bias was determined using a 4-cell continuous electrodeionization module, with a nominal flow rate capacity of 1.9 L/min (0.5 gpm). The module was tested in triplicate by six operators in one laboratory. The operators who participated represented a wide range of experience levels. Since other sources of variability should be relatively small (such as from the conductivity meter), the multiple laboratory variability is expected to mimic the single-operator precision and is not separately determined. The following results were obtained for the CEDI module performance:

Deionization	$x = 99.78$ (% removal, based on conductivity)
	$S_o = 0.05$ (% removal, based on conductivity)
Electrical resistance	$x = 80.8$ (ohms)
	$S_o = 4.3$ (ohms)
Dilute pressure drop	$x = 101.4$ (kPa)
	$S_o = 9.7$ (kPa)
Concentrate pressure drop	$x = 45.5$ (kPa)
	$S_o = 5.5$ (kPa)

where:

- $x$  = arithmetic mean of the 18 determinations, and
- $S_o$  = single-operator precision calculated in accordance with Practice [D2777](#).

10.2 Since known standards are not available, bias can not be determined.

## 11. Keywords

11.1 continuous electrodeionization; deionization; electrical current efficiency; electrical resistance; electrodeionization; electroregeneration; high purity water; pressure differential

## ANNEX

### (Mandatory Information)

#### A1. SAMPLE TEST DATA SHEET



**TABLE A1.1 ATTACHMENT A—SAMPLE TEST DATA SHEET**

CEDI PERFORMANCE TEST—RO PERMEATE FEED, 2 to 100 $\mu\text{S}/\text{cm}$								
TEST PARAMETER	UNITS	0 V/CELL	1 V/CELL	2 V/CELL	3 V/CELL	3.5 V/CELL	4 V/CELL	FINAL VOLTS
ELAPSED TIME	minutes	0.0						
FEED pH	pH							
FEED TEMPERATURE	$^{\circ}\text{C}$							
FEED CONDUCTIVITY	$\mu\text{S}/\text{cm}$							
PRODUCT CONDUCTIVITY	$\mu\text{S}/\text{cm}$							
CONCENTRATE CONDUCTIVITY	$\mu\text{S}/\text{cm}$							
SALT REMOVAL	%	--						
DC VOLTAGE	volts	0.0						
DC CURRENT	amps	0.0						
CURRENT EFFICIENCY	%	--						
DILUTE FLOW RATE	gpm							
CONCENTRATE FLOW RATE	gpm							
ELECTRODE FLOW RATE	gph							
ELECTRODE INLET PRESSURE	psig							
DILUTE INLET PRESSURE	psig							
DILUTE OUTLET PRESSURE	psig							
DILUTE DP (INLET-OUTLET)	psid							
CONC INLET PRESSURE	psig							
CONC OUTLET PRESSURE	psig							
CONC DP (INLET-OUTLET)	psid							
FEED $\text{SiO}_2$	mg/L							
PRODUCT $\text{SiO}_2$	mg/L							
CONCENTRATE $\text{SiO}_2$	mg/L							
FEED $\text{CO}_2$	mg/L							
PRODUCT $\text{CO}_2$	mg/L							
CONCENTRATE $\text{CO}_2$	mg/L							

ASTM International takes no position respecting the validity of any patent rights asserted in connection with any item mentioned in this standard. Users of this standard are expressly advised that determination of the validity of any such patent rights, and the risk of infringement of such rights, are entirely their own responsibility.

This standard is subject to revision at any time by the responsible technical committee and must be reviewed every five years and if not revised, either reapproved or withdrawn. Your comments are invited either for revision of this standard or for additional standards and should be addressed to ASTM International Headquarters. Your comments will receive careful consideration at a meeting of the responsible technical committee, which you may attend. If you feel that your comments have not received a fair hearing you should make your views known to the ASTM Committee on Standards, at the address shown below.

This standard is copyrighted by ASTM International, 100 Barr Harbor Drive, PO Box C700, West Conshohocken, PA 19428-2959, United States. Individual reprints (single or multiple copies) of this standard may be obtained by contacting ASTM at the above address or at 610-832-9585 (phone), 610-832-9555 (fax), or [service@astm.org](mailto:service@astm.org) (e-mail); or through the ASTM website ([www.astm.org](http://www.astm.org)). Permission rights to photocopy the standard may also be secured from the Copyright Clearance Center, 222 Rosewood Drive, Danvers, MA 01923, Tel: (978) 646-2600; <http://www.copyright.com/>