



# Standard Specification for Polymer Concrete Pipe<sup>1</sup>

This standard is issued under the fixed designation D6783; the number immediately following the designation indicates the year of original adoption or, in the case of revision, the year of last revision. A number in parentheses indicates the year of last reapproval. A superscript epsilon ( $\epsilon$ ) indicates an editorial change since the last revision or reapproval.

## 1. Scope

1.1 This specification covers polymer concrete pipe, 6 in. (150 mm) through 144 in. (3 660 mm), intended for use in gravity-flow systems for conveying sanitary sewage, storm water, and industrial wastes.

1.2 Although this specification is suited primarily for pipe to be installed by direct burial and pipe jacking, it may be used to the extent applicable for other installations such as sliplining and rehabilitation of existing pipelines.

NOTE 1—Unlike reinforced thermosetting resin pipes, polymer concrete pipe is designed and installed using rigid pipe design theory and practices.

1.3 The values stated in inch-pound units are to be regarded as the standard. The values given in parentheses are for information only.

1.4 The following safety hazards caveat pertains only to the test methods portion, Section 8, of this specification. *This standard may involve hazardous materials, operations, and equipment. This standard does not purport to address all of the safety concerns, if any, associated with its use. It is the responsibility of the user of this standard to establish appropriate safety and health practices and determine the applicability of regulatory requirements prior to use.*

NOTE 2—There is no known ISO equivalent to this standard.

## 2. Referenced Documents

### 2.1 ASTM Standards:<sup>2</sup>

- A276 Specification for Stainless Steel Bars and Shapes
- C33 Specification for Concrete Aggregates
- C117 Test Method for Materials Finer than 75- $\mu$ m (No. 200) Sieve in Mineral Aggregates by Washing
- C125 Terminology Relating to Concrete and Concrete Aggregates

<sup>1</sup> This specification is under the jurisdiction of ASTM Committee D20 on Plastics and is the direct responsibility of Subcommittee D20.23 on Reinforced Plastic Piping Systems and Chemical Equipment.

Current edition approved Feb. 1, 2011. Published March 2011. Originally approved in 2002. Last previous edition approved in 2005 as D6783 - 05. DOI: 10.1520/D6783-05R11.

<sup>2</sup> For referenced ASTM standards, visit the ASTM website, www.astm.org, or contact ASTM Customer Service at service@astm.org. For *Annual Book of ASTM Standards* volume information, refer to the standard's Document Summary page on the ASTM website.

- C136 Test Method for Sieve Analysis of Fine and Coarse Aggregates
- C579 Test Methods for Compressive Strength of Chemical-Resistant Mortars, Grouts, Monolithic Surfacing, and Polymer Concretes
- D648 Test Method for Deflection Temperature of Plastics Under Flexural Load in the Edgewise Position
- D883 Terminology Relating to Plastics
- D1600 Terminology for Abbreviated Terms Relating to Plastics
- D2584 Test Method for Ignition Loss of Cured Reinforced Resins
- D3567 Practice for Determining Dimensions of "Fiberglass" (Glass-Fiber-Reinforced Thermosetting Resin) Pipe and Fittings
- D3681 Test Method for Chemical Resistance of "Fiberglass" (Glass-Fiber-Reinforced Thermosetting-Resin) Pipe in a Deflected Condition
- D3892 Practice for Packaging/Packing of Plastics
- D4161 Specification for "Fiberglass" (Glass-Fiber-Reinforced Thermosetting-Resin) Pipe Joints Using Flexible Elastomeric Seals
- F412 Terminology Relating to Plastic Piping Systems
- F477 Specification for Elastomeric Seals (Gaskets) for Joining Plastic Pipe

## 3. Terminology

3.1 *Definitions*—Unless otherwise indicated, definitions are in accordance with Terminologies C125, D883, and F412, and abbreviations are in accordance with Terminology D1600.

### 3.2 *Definitions of Terms Specific to This Standard:*

3.2.1 *aggregate, n*—a granular material, such as sand, gravel, or crushed stone, in accordance with to the requirements of Specification C33 except that the requirements for gradation shall not apply.

3.2.2 *pipe jacking, n*—a system of directly installing pipes behind a shield machine by hydraulic jacking from a drive shaft, such that the pipes form a continuous string in the ground.

3.2.3 *polymer concrete, n*—a composite material that consists essentially of a thermosetting resin within which are embedded particles or fragments of aggregate.

3.2.4 *polymer concrete pipe, n*—tubular product containing aggregate, embedded in or surrounded by cured thermosetting resin, which may also contain granular or platelet fillers, thixotropic agents, pigments, or dyes.

3.2.5 *qualification test, n*—one or more tests used to prove the design of a product and which are not routine quality control tests.

**4. Classification**

4.1 Polymer concrete pipe furnished under this specification is manufactured in strength classes I, II, III, IV, or V as given in Table 1. (See also Note 5.)

NOTE 3—The D-Load is the three-edge bearing strength per unit length divided by the inside diameter.

NOTE 4—Other strength categories shall be permitted by agreement between the purchaser and the manufacturer.

**5. Materials and Manufacture**

5.1 *Wall Composition*—The wall composition shall consist of a thermosetting resin and aggregate.

5.1.1 *Thermosetting Resin*—The resin shall have a minimum deflection temperature of 158°F (70°C) when tested at 264 psi (1.820 mPa) following Test Method D648. The resin content shall not be less than 7 % of the weight of the sample as determined by Test Method D2584.

5.1.2 *Aggregate*—Aggregate, and mineral fillers tested in accordance with all requirements of Test Methods C117 and C136, except requirements for gradation shall not apply.

5.2 *Joints*—The pipe shall have a gasket sealed joining system that shall prevent leakage of fluid in the intended service condition.

5.2.1 *Couplings*—Stainless Steel 316, in accordance with Specification A276, or a glass-fiber-reinforced-thermosetting-resin coupling which uses an elastomeric seal. Alternate materials may be permitted by agreement between the purchaser and the manufacturer. Figs. 1 and 2 show typical couplings.

5.2.2 *Gaskets*—Elastomeric gaskets used with this pipe shall conform to the requirements of Specification F477, except that composition of the elastomer shall be as agreed upon between the purchaser and the supplier as being resistant to the intended chemical environments.

**6. Requirements**

6.1 *Workmanship*—Each pipe shall be free from all defects, including indentations, cracks, foreign inclusions, and resin-starved areas that, due to their nature, degree, or extent, detrimentally affect the strength and serviceability of the pipe.

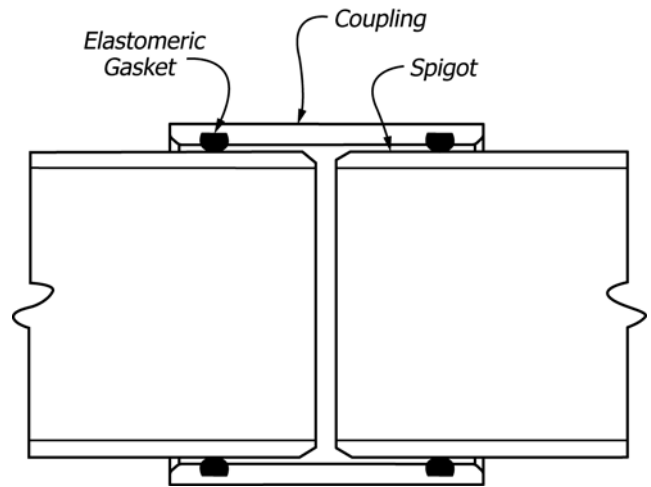

FIG. 1 Typical Coupling Joint Detail

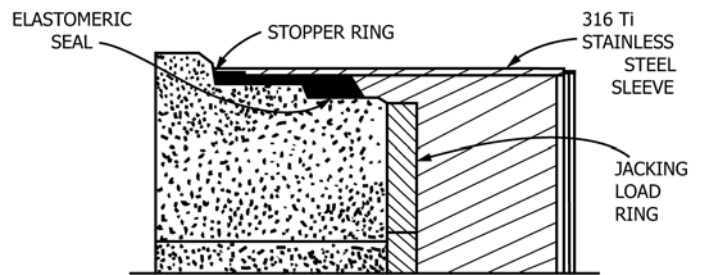

FIG. 2 Typical Jacking Pipe Joint

The pipe shall be as uniform as commercially practicable in color, opacity, density, and other physical properties.

6.1.1 The inside surface of each pipe shall be free of bulges, dents, ridges, and other defects that result in a variation of inside diameter of more than 1/8 in. (3.2 mm) from that obtained on adjacent unaffected portions of the surface.

6.1.2 Joint sealing surfaces shall be free of dents, gouges, and other surface irregularities that will affect the integrity of the joints.

6.2 *Dimensions:*

6.2.1 *Pipe Diameter*—The pipe shall be supplied in the nominal diameters shown in Table 2 when measured in accordance with 8.1.1.

6.2.2 *Lengths*—Pipe shall be supplied in nominal lengths of 3, 4, 5, 6, 8, and 10 ft. (0.92, 1.22, 1.52, 1.83, 2.44, and 3.05 m) unless otherwise agreed to between purchaser and seller. Tolerance on length shall be ±2 in. (±50 mm). The pipe shall be measured in accordance with 8.1.2.

6.2.3 *Wall Thickness*—The average wall thickness of the pipe shall not be less than the nominal wall thickness published in the manufacturer’s literature current at the time of purchase, when measured in accordance with 8.1.3.

6.2.4 *Straightness of Pipe:*

6.2.4.1 *Direct Bury Pipe*—Pipes shall not deviate from straight by more than 0.10 in/ft (8.3mm/m) for nominal diameters through 39 inch, 0.12 in/ft (10mm/m) for nominal diameters 42 in. through 78 in. and 0.14 in/ft (11.7mm/m) for nominal diameters 84 in. through 144 in. when measured in accordance with 8.1.4.

TABLE 1 Strength Classes for Polymer Concrete Pipe

Strength Class	D-Load lb/ft/ft (kN/m/m)
I	1200 (57.5)
II	1500 (71.9)
III	2000 (95.8)
IV	3000 (143.8)
V	3750 (179.7)

**TABLE 2 Diameters for Polymer Concrete Pipe**

Nominal Diameter, in.	Inside Diameter in. (mm)	Tolerance on ID in. (mm)
6	6.00 (152.4)	± 0.25 (6.4)
8	8.00 (203.2)	± 0.25 (6.4)
10	10.00 (254.0)	± 0.25 (6.4)
12	12.00 (304.8)	± 0.25 (6.4)
14	14.00 (355.6)	± 0.25 (6.4)
15	15.00 (381.0)	± 0.25 (6.4)
16	16.00 (406.4)	± 0.25 (6.4)
18	18.00 (457.2)	± 0.25 (6.4)
20	20.00 (508.0)	± 0.25 (6.4)
21	21.00 (533.4)	± 0.25 (6.4)
24	24.00 (609.6)	± 0.25 (6.4)
27	27.00 (685.8)	± 0.27 (6.4)
30	30.00 (762.0)	± 0.30 (7.6)
33	33.00 (838.2)	± 0.33 (8.4)
36	36.00 (914.4)	± 0.36 (9.1)
39	39.00 (990.6)	± 0.39 (9.9)
42	42.00 (1066.8)	± 0.42 (10.7)
45	45.00 (1143.0)	± 0.45 (11.4)
48	48.00 (1219.2)	± 0.48 (12.2)
51	51.00 (1295.4)	± 0.51 (13.0)
54	54.00 (1371.6)	± 0.54 (13.7)
60	60.00 (1524.0)	± 0.60 (15.2)
66	66.00 (1676.4)	± 0.66 (16.8)
72	72.00 (1828.8)	± 0.72 (18.3)
78	78.00 (1981.2)	± 0.78 (19.8)
84	84.00 (2133.6)	± 0.84 (21.3)
90	90.00 (2286.0)	± 0.90 (22.9)
96	96.00 (2438.4)	± 0.96 (24.4)
102	102.00 (2590.8)	± 1.00 (25.4)
108	108.00 (2743.2)	± 1.00 (25.4)
114	114.00 (2895.6)	± 1.00 (25.4)
120	120.00 (3048.0)	± 1.00 (25.4)
132	132.00 (3352.8)	± 1.00 (25.4)
144	144.00 (3657.6)	± 1.00 (25.4)

NOTE 1—Other diameters shall be permitted by agreement between the purchaser and the manufacturer.

6.2.4.2 *Jacking Pipe*—Pipes shall not deviate from straight by more than 0.04 in./ft (3.3 mm/m) for nominal diameters through 39 inch, 0.06 in./ft (5.0mm/m) for nominal diameters 42 in. through 78 in., and 0.08 in./ft (6.7mm/m) for nominal diameters 84 in. through 144 in. when measured in accordance with 8.1.4.

6.2.5 *Roundness of Pipe*—The outside diameter shall not vary from a true circle by more than 1.0 % when measured in accordance with 8.1.5.

6.2.6 *Squareness of Pipe Ends:*

6.2.6.1 *Direct Bury Pipe*—The ends of the pipe shall be perpendicular to the longitudinal axis within ± 0.25 in (± 6.4 mm) or ± 0.5 % of the nominal diameter, whichever is the greater, when tested when tested in accordance with 8.1.6

6.2.6.2 *Jacking Pipe* —The ends of the pipe shall be perpendicular to the longitudinal axis within 0.06 in (1.5mm) for nominal diameters through 39 inch, 0.12 inch (3mm) for nominal diameters 42 inch through 102 inch and 0.20 inch (5mm) for diameters 108 inch through 144 inch, when tested in accordance with 8.1.6.

6.3 *Three-Edge Bearing*—The pipe shall withstand, without failure, the three-edge bearing loads specified in Table 1 when tested in accordance with 8.2.

6.4 *Hydrostatic Pressure*—The pipe shall withstand an internal pressure of 35 psi (0.25 mPa) when tested in accordance with 8.3.

6.5 *Compressive Strength*—The minimum axial compressive strength shall be 10 000 psi (68.9 mPa) when tested in accordance with 8.4.

6.6 *Chemical Resistance:*

6.6.1 *Long Term*—When tested in accordance with 8.5, the extrapolated 50 year strength value shall be at least 50 % of the initial three-edge bearing strength of the test pipes.

6.6.2 *Control Requirements*—When tested in accordance with 8.5, pipe specimens shall be capable of sustaining without failure for 1 000 h a load equal to 60 % of the initial three-edge bearing strength of the test pipes.

6.7 *Joint Tightness:*

6.7.1 *Direct Bury Pipe*—The joint shall meet the laboratory performance requirements of Specification D4161, except that the internal pressure shall be 35 psi (0.25 mPa) and the minimum test time shall be 15 min.

6.7.2 *Jacking Pipe*—The joint shall meet the laboratory performance requirements of Specification D4161, except that the internal pressure shall be 35 psi (0.25 mPa), the minimum test time shall be 15 min, and the joint angle as illustrated in Fig. 2 of D4161 shall not apply. The joint test angle shall be the maximum allowed deflection angle as designed and specified by the manufacturer, but shall not be less than 0.50 degrees.

## 7. Sampling

7.1 *Lot*—Unless otherwise agreed upon between the purchaser and supplier, one lot shall consist of a manufacturing run of no more than 100, but at least 20, lengths of pipe of each diameter and strength class produced.

7.2 *Production Tests*—Select one pipe at random from each lot to determine conformance of the material to the workmanship, dimensional, and physical requirements of 6.1, 6.2, 6.3 and 6.5, respectively.

7.2.1 *Pipe Acceptance*—If the tested specimen of a designated lot passes the test, the entire lot shall be acceptable. If the tested specimen of a designated lot fails to pass the test, then five additional specimens from that same lot shall be selected for testing. If the five additional specimens pass, the lot shall be acceptable. except the one previous failing specimen. If any of the five additional specimens fail, the entire lot shall be rejected.

7.3 *Qualification Tests*—Sampling for qualification tests (see 3.2.5) is not required unless otherwise agreed upon between the purchaser and the manufacturer. Qualification tests shall be conducted for changes in polymer aggregate and manufacturing process and for changes in pipe joint or gasket geometry. Qualification tests for which a certification and test report shall be furnished when requested by the purchaser include the following:

7.3.1 *Hydrostatic Pressure Test*—(see 6.4).

7.3.2 *Chemical Resistance Test*—(see 6.6).

7.3.3 *Joint-Tightness Test*—(see 6.7).

7.4 *Control for Chemical Resistance Test*—Perform sampling and testing for the control requirements of the chemical resistance test at least once annually, unless otherwise agreed upon between the purchaser and the supplier.

7.5 For individual orders, conduct only those additional tests and number of tests specifically agreed upon between the purchaser and the supplier.

## 8. Test Methods

### 8.1 Dimensions:

#### 8.1.1 Diameters:

8.1.1.1 *Inside Diameter*—Take inside diameter measurements at a point approximately 6 in. (152 mm) from the end of the pipe section using a steel tape or an inside micrometer with graduations of  $\frac{1}{16}$  in. (1 mm) or less. Make two 90° opposing measurements at each point of measurement and average the readings.

8.1.1.2 *Outside Diameter*—Determine in accordance with Practice **D3567**.

8.1.2 *Length*—Measure the pipe with a steel tape or gage having graduations of  $\frac{1}{16}$  in. (1 mm) or less. Lay the tape or gage on or inside the pipe and measure the overall length of the pipe.

8.1.3 *Wall-Thickness*—Determine in accordance with Practice **D3567**.

8.1.4 *Straightness of Pipe*—Place a straight edge along the entire length of the pipe barrel. Measure the maximum deviation from straightness. Take four measurements at 90° intervals around the pipe and report the maximum deviation.

8.1.5 *Roundness of Pipe*—Measure the maximum and minimum outside diameters at one location on the joint sealing surface of the pipe. The out of roundness is the difference between these two measurements.

8.1.6 *Squareness of Pipe Ends*—Place pipe on supports in a horizontal position. Measure against a flat surface or plane that is perpendicular to the pipe axis. Rotate the pipe and measure the maximum and minimum distances from the pipe end to the flat surface or plane that is perpendicular to the pipe axis. The squareness is the difference between the maximum and minimum values.

### 8.2 Three-Edge Bearing Test:

8.2.1 The test specimens shall be standard lengths of pipe or other lengths as approved by the purchaser.

#### 8.2.2 Three-Edge Testing Apparatus (see **Fig. 3**):

8.2.2.1 The apparatus shall consist of hydraulic rams mounted in a frame, and that are capable of applying uniform loads to the pipe through an I-beam along the entire upper length of the test specimen.

8.2.2.2 The contact surfaces shall be an elastomeric material having a shore A instantaneous durometer hardness between 45 and 60.

8.2.2.3 The top contact surface shall be of rectangular cross-section, having an 8 in. (200 mm) width and a thickness not less than 1 in. (25 mm) or more than  $1\frac{1}{2}$  in. (38 mm).

8.2.2.4 The bottom part of the apparatus shall consist of a firmly positioned I-beam supporting the entire length of the pipe, positioned in the vertical plane, passing through the longitudinal axis of the pipe. Two contact surfaces of rectangular cross-section, having a 2 in. (51 mm) width, and a thickness not less than 1 in. (25 mm) nor more than  $1\frac{1}{2}$  in. (38 mm) shall be attached to the entire length of the lower I-beam.

The bottom contact surfaces shall be spaced apart 1 in./ft. (83 mm/m) of pipe diameter, but in no case less than 1 in. (25 mm).

8.2.2.5 The apparatus shall be capable of applying a load at a uniform rate of  $2\,000 \pm 500$  lbf/min/linear ft ( $29.4 \pm 7.4$  kN/min/linear m).

### 8.2.3 Test Procedure:

8.2.3.1 The load shall be applied at a uniform rate of  $2\,000 \pm 500$  lbf/min/linear ft ( $29.4 \pm 7.4$  kN/min/linear m) of pipe length.

8.2.3.2 Test each pipe specimen in accordance with this method until the load required for the strength class (see **Table 1**) has been reached without visible damage to the pipe. The loading may be stopped after the required strength has been met, but before the pipe fails. Calculate the three-edge bearing strength by dividing the applied load by the inside length of the barrel. Calculate the D-Load by dividing the three-edge bearing strength by the inside diameter.

8.3 *Hydrostatic Pressure Test*—When the pipe is subjected to an internal hydrostatic pressure of 35 psi (0.25 mPa), and tested with restrained ends for 15 min there shall be no leakage on the exterior of the pipe. Moisture appearing on the surface of the pipe in the form of beads adhering to the surface shall not be considered leakage. However, moisture that starts to run on the pipe shall be construed as leakage, regardless of the quantity.

8.4 *Compressive Strength Test*—Determine in accordance with Test Method B of Test Method **C579** except that the test specimens shall be sections cut from pipe with a dimensional ratio of 1:1:2 with a minimum cross-sectional area of

1 in.<sup>2</sup> (650 mm<sup>2</sup>). The longest dimension shall be in the direction of the longitudinal axis of the pipe. Test specimens may be also taken from samples molded at the same time as the pipe is produced, using the same materials used to manufacture the pipe.

### 8.5 Chemical Resistance Test:

8.5.1 *Test Specimens*—The test specimens shall be ring sections taken from pipes selected at random from a production run of pipe.

8.5.1.1 *Length*—The test specimens shall have a length of 12 in. (300 mm)  $\pm 5\%$ .

8.5.1.2 *Diameter*—The test specimens shall all be of the same nominal diameter and strength class.

8.5.2 *Apparatus*—The loading frame shall be capable of applying and maintaining a load perpendicular to the pipe axis throughout the test period, despite any change in the vertical diameter of the test specimen. The loading frame contact surfaces shall conform to **8.2.2.2 – 8.2.2.4**.

8.5.3 *Load Application Systems*—The test loads may be applied by hydraulic means or by springs (**Fig. 4** shows a typical system) or may be applied by the use of dead weights (**Fig. 5** shows a typical fulcrum and weight loading system).

8.5.3.1 *Hydraulic Loading*—The use of a hydraulic loading system allows several specimens to be loaded simultaneously through a central hydraulic pressure-regulating unit. Such a unit typically consists of an accumulator, a regulator, a calibrated pressure gauge, and a source of high-pressure, such as a cylinder of nitrogen or a high-pressure pump system. The



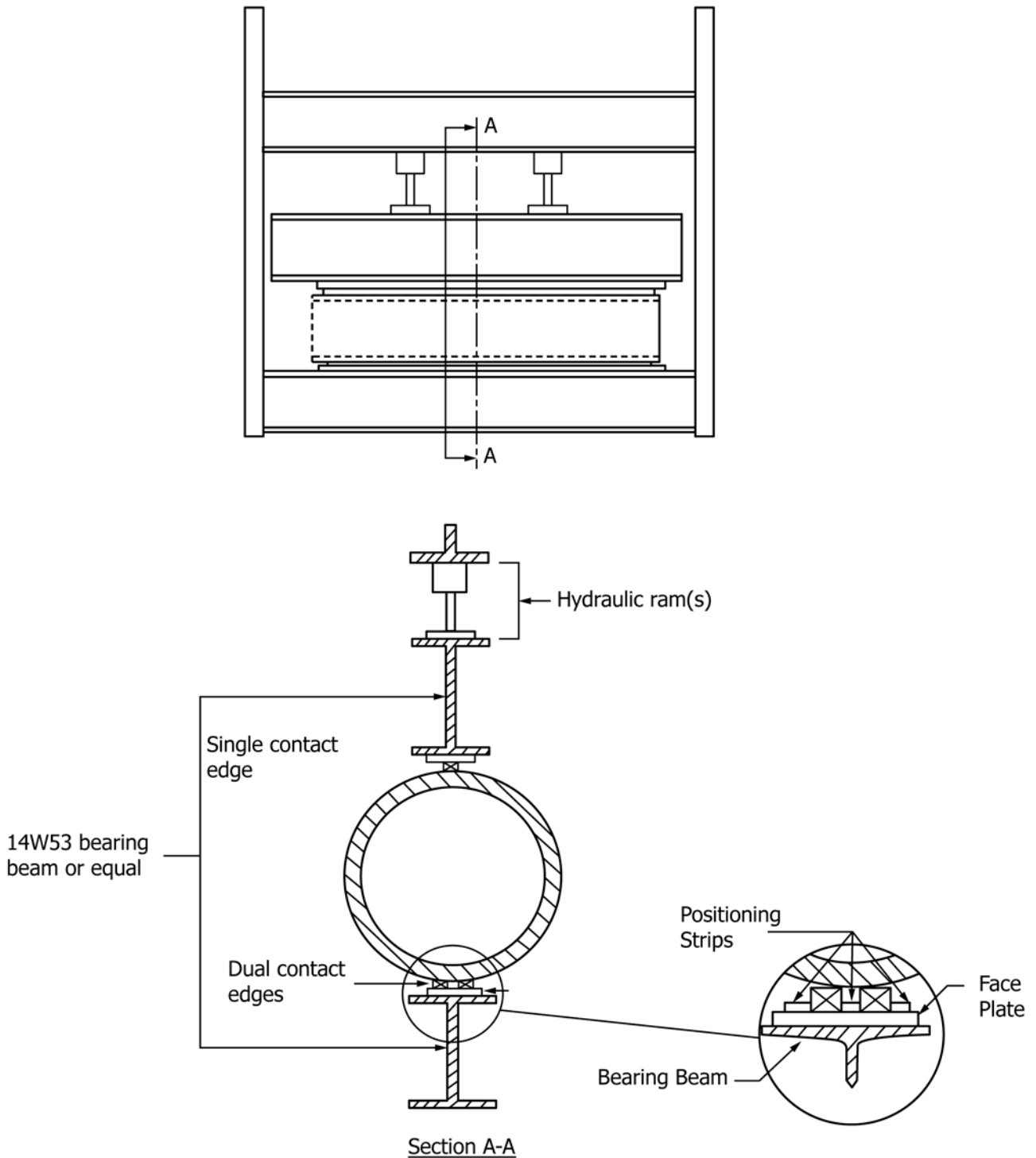

FIG. 3 Three-Edge Bearing Test

system shall be capable of applying and maintaining the load to  $\pm 2\%$  of the test load.

8.5.3.2 *Spring Loading*—When springs are used as the load application system, a spherical head or ball joint shall be provided to evenly distribute the load to the load plate. Prior to assembly in the test frame, the load applied by the springs must be determined by a load deflection curve (spring-rate). This may be established by calibrating the springs in a testing

machine capable of producing a load-deflection graph or a numerical print-out. For larger pipe specimens, springs, such as railroad car springs, have been found useful. The system shall be capable of applying and maintaining the load to  $\pm 2\%$  of the test load, which may be measured by inserting a load cell into the testing frame.

8.5.3.3 *Dead Weight Loading*—A typical arrangement of the test apparatus is shown in Fig. 5. The apparatus consists of a

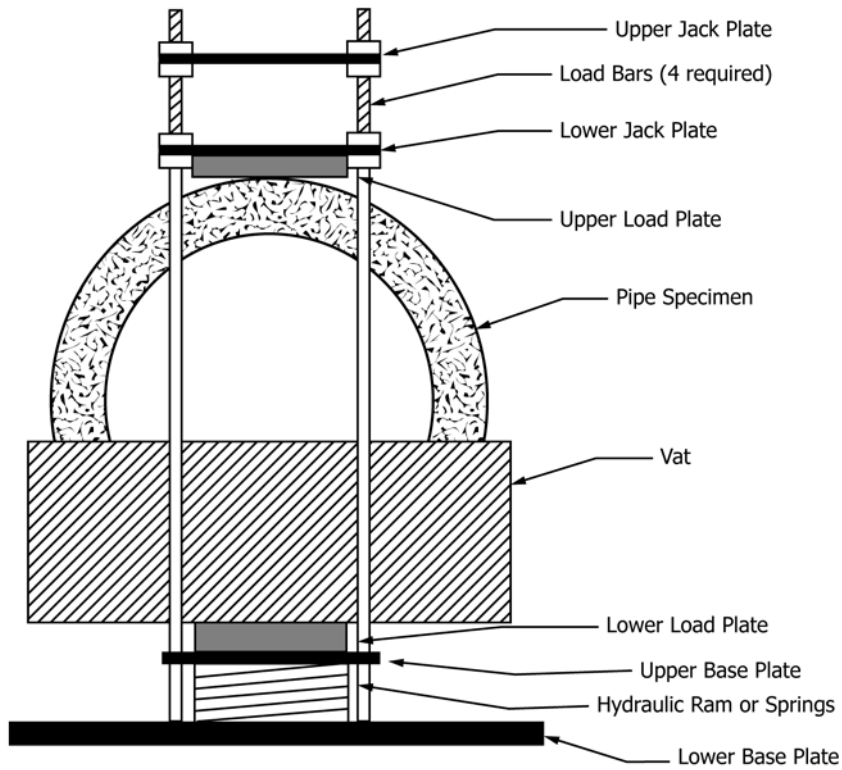

FIG. 4 Loading Frame for Chemical Resistance Test

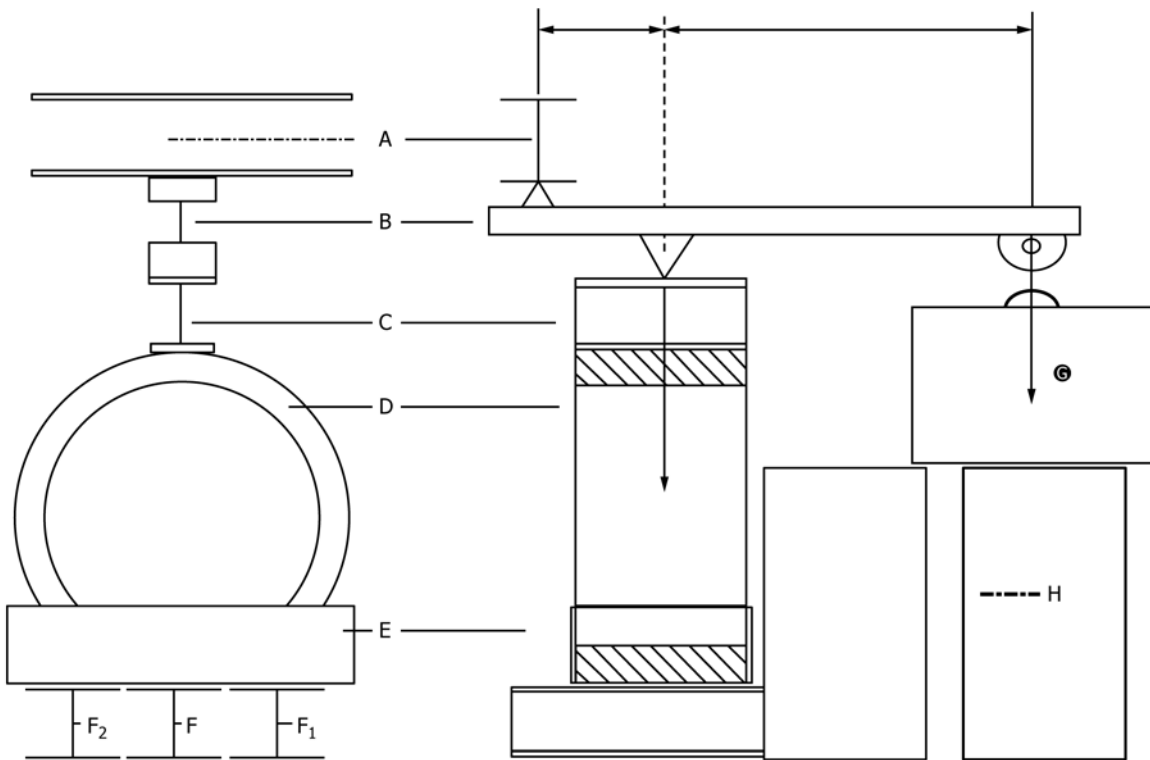

FIG. 5 Alternate Loading Frame for Chemical Resistance Test

rigid beam placed parallel to the floor (A), a rigid work-arm to introduce the load with a ring on one end to attach weights (B), a rigid bearing beam parallel to the floor (C), rigid support

beams (F), a container suitable for carrying the test solution (E), concrete weights (G), and a drop protection for the weights (H).

### 8.5.4 Test Procedure:

8.5.4.1 *Short-Term Load*—Determine the short-term strength by the three-edge bearing strength test as given in 8.2. Test a minimum of three specimens from each pipe from which test samples have been obtained. Average the results of the tests for each pipe and report as the 100 % short-term load for that pipe.

8.5.4.2 *Long-Term Loading*—Assemble the test specimen into the loading frame, apply the selected test load, apply flexible dams across the pipe ends at the bottom, and within 30 min, fill the specimen with the test solution to a level that covers the invert to a minimum depth of 1 in. (25 mm). Test time is recorded from the time of addition of the test solution. Periodically check and maintain the test solution over the life of the test to  $\pm 5$  % of the specified level.

(1) *Number of Tests*—For each specified test solution, test at least 18 test specimens at various percentages of the short-term load. The distribution of data points should be as follows:

Hours	Failure Points
10 to 1 000	4
1 000 to 6 000	3
After 6 000	3
After 10 000	1

(2) Perform inspection of the test samples as follows:

Hours	Inspect at Least
0 to 20	every 1 h
20 to 40	every 2 h
40 to 60	every 4 h
60 to 100	every 8 h
100 to 600	every 24 $\pm$ 6 h
600 to 6 000	every 48 $\pm$ 10 h
After 6 000	every week

(3) Record the time to failure of each test specimen. Those specimens that have not failed after more than 10 000 h may be included as failures to establish the regression line.

(4) Analyze the test results using, for each specimen, the percentage of short-term load and the time to failure. Determine and report the regression line and the extrapolated 50 year value, as a percentage of short term load, using the method of log-log linear least squares analysis as given in Annex A1 of Test Method **D3681**.

(5) *Test Solutions*—Conduct the long-term load test in each of the following test solutions.

(a) *Acidic*—The test solution shall be 1.0 N sulfuric acid.

(b) *Alkali*—The test solution shall be water and sodium hydroxide at a pH of 10.0.

8.5.4.3 *Control Tests*—Test at least six samples at a load equal to 60 % of the test pipes initial three-edge bearing strength.

NOTE 5—The engineer may wish to consider the value obtained for long term chemical resistance in selecting a service factor for a particular application.

## 9. Packing, Marking, and Shipping

9.1 Mark each length of pipe that meets or is part of a lot that meets the requirements of this specification in letters not less than ½ in. (12 mm) in height. Use a bold-type style in a color and type that remains legible under normal handling and installing procedures. The marking shall include the nominal pipe size, manufacturer's name or trademark, this ASTM Specification D6783, and the strength class.

9.2 Prepare pipe for commercial shipment in such a way as to ensure acceptance by common or other carriers.

9.3 All packing, packaging, and marking provisions of Practice **D3892** shall apply to this specification.

## 10. Precision and Bias

10.1 No precision and bias statement can be made for the Three-Edge Bearing Test and the Chemical Resistance Test Methods since controlled round robin test programs have not been conducted. These test methods are generally used to evaluate polymer concrete pipe.

## 11. Keywords

11.1 industrial waste piping; pipe jacking; polymer concrete; sanitary sewers; storm drains

*ASTM International takes no position respecting the validity of any patent rights asserted in connection with any item mentioned in this standard. Users of this standard are expressly advised that determination of the validity of any such patent rights, and the risk of infringement of such rights, are entirely their own responsibility.*

*This standard is subject to revision at any time by the responsible technical committee and must be reviewed every five years and if not revised, either reapproved or withdrawn. Your comments are invited either for revision of this standard or for additional standards and should be addressed to ASTM International Headquarters. Your comments will receive careful consideration at a meeting of the responsible technical committee, which you may attend. If you feel that your comments have not received a fair hearing you should make your views known to the ASTM Committee on Standards, at the address shown below.*

*This standard is copyrighted by ASTM International, 100 Barr Harbor Drive, PO Box C700, West Conshohocken, PA 19428-2959, United States. Individual reprints (single or multiple copies) of this standard may be obtained by contacting ASTM at the above address or at 610-832-9585 (phone), 610-832-9555 (fax), or service@astm.org (e-mail); or through the ASTM website (www.astm.org). Permission rights to photocopy the standard may also be secured from the Copyright Clearance Center, 222 Rosewood Drive, Danvers, MA 01923, Tel: (978) 646-2600; http://www.copyright.com/*