



Standard Test Method for Relative Rigidity of Poly(Vinyl Chloride)(PVC) Siding¹

This standard is issued under the fixed designation D6777; the number immediately following the designation indicates the year of original adoption or, in the case of revision, the year of last revision. A number in parentheses indicates the year of last reapproval. A superscript epsilon (ϵ) indicates an editorial change since the last revision or reapproval.

1. Scope*

1.1 This procedure describes a method to determine a numerical value indicating the relative rigidity or stiffness of vinyl siding panels. This procedure is not intended for routine quality control inspection during the manufacture of vinyl siding. The rigidity of vinyl siding is believed to be controlled primarily by its configuration and is not believed to be significantly influenced by manufacturing variables.

1.2 Vinyl siding with higher rigidity is often easier to handle and install than siding of lower rigidity. It is expected to provide a straighter appearance when installed on walls having an uneven surface.

1.3 All other vinyl siding requirements and test methods can be identified through Specification [D3679](#).

1.4 There is no known ISO equivalent to this standard.

1.5 *This standard does not purport to address all of the safety concerns, if any, associated with its use. It is the responsibility of the user of this standard to establish appropriate safety and health practices and determine the applicability of regulatory limitations prior to use.*

2. Referenced Documents

2.1 ASTM Standards:²

[D618 Practice for Conditioning Plastics for Testing](#)

[D883 Terminology Relating to Plastics](#)

[D1600 Terminology for Abbreviated Terms Relating to Plastics](#)

[D3679 Specification for Rigid Poly\(Vinyl Chloride\) \(PVC\) Siding](#)

[D5947 Test Methods for Physical Dimensions of Solid Plastics Specimens](#)

¹ This test method is under the jurisdiction of ASTM Committee [D20](#) on Plastics and is the direct responsibility of Subcommittee [D20.24](#) on Plastic Building Products.

Current edition approved May 1, 2016. Published May 2016. Originally approved in 2002. Last previous edition approved in 2010 as [D6777 - 02\(2010\)](#) ^{ϵ 1}. DOI:10.1520/D6777-16.

² For referenced ASTM standards, visit the ASTM website, www.astm.org, or contact ASTM Customer Service at service@astm.org. For *Annual Book of ASTM Standards* volume information, refer to the standard's Document Summary page on the ASTM website.

3. Terminology

3.1 *Definitions*—Definitions are in accordance with Terminology [D883](#) and [D1600](#) unless otherwise indicated.

3.2 Definitions of Terms Specific to This Standard:

3.2.1 *relative rigidity (of PVC siding)*—stiffness of a piece of vinyl siding.

3.2.2 *rigidity index (of PVC siding)*—amount of sample sag or deflection relative to sample length. The “rigidity index” is defined as 100 minus the deflection value, divided by the sample length, expressed as a percentage.

4. Summary of Test Method

4.1 In this procedure the test specimen is a piece of vinyl siding 100 in. long. This specimen is placed on top of a level table with 50 in. of the specimen extending unsupported past the edge of the table, allowing the specimen to sag under its own weight. The amount of sag that occurs is used to calculate a rigidity index for the sample.

5. Significance and Use

5.1 Vinyl siding with higher rigidity is often easier to install than siding with lower rigidity and expected to provide a straighter appearance when installed on walls having an uneven surface.

5.2 The rigidity of vinyl siding is believed to be controlled primarily its characteristic configuration and is not believed to be significantly influenced by manufacturing variables. Siding weight has little influence on this test.

6. Interferences

6.1 The supporting table and floor must be flat and level. Calibrations of flatness, parallelism, and levelness, as described in [9.2-9.4](#) shall be performed before running this test.

7. Apparatus

7.1 This procedure requires a table that is flat and level. The table must be at least 50 in. long and at least as wide as the widest test specimen to be measured. The height of the table is not critical. The edge of the table over which the specimen will extend shall not have a radius more than 0.125 in. The table must be positioned on a hard surface or floor (no carpet) that is also flat and level over a length extending at least 50 in. from the edge of the table.

*A Summary of Changes section appears at the end of this standard

7.2 A weight consisting of a 5 lb sand bag is used to hold the end of the siding specimen firmly against the table top. The weight shall be as wide as the widest siding specimen to be tested.

7.3 A line shall be drawn on the table to ensuring that the specimens are positioned perpendicular to the edge of the table. This line shall be drawn as a perpendicular to the edge using a large framing square at least 10 in. on each side.

7.4 A rigid ruler (such as a folding carpenter's ruler or large metal framing square) is used to measure the distance from the floor to the table top and the suspended end of the siding specimen. This ruler needs to be at least one inch longer than the height of the table, and shall be scribed to allow measurements to the nearest $\frac{1}{16}$ in.

NOTE 1—It is recommended that the end of the ruler being placed against the floor be protected with a cap to prevent abrasive wear.

7.5 A tape measure is used to measure the length of the siding specimen. This tape measure needs to be at least 101 in. long, and shall be scribed to allow measurements to the nearest $\frac{1}{16}$ in.

8. Sampling, Test Specimens, and Test Units

8.1 The test specimen shall be taken from a vinyl siding panel complying with Specification **D3679**. The siding panel as tested shall be complete with any weep holes or nail slots as required for installation per the manufacturer's design. The specimen shall be cut to a length of 100 ± 0.25 in. as measured according to the procedure in Specification **D3679** section 6.3. The specimen shall be cut so that there are no notches on the end which will extend off the table. Both ends of the specimen shall be cut squarely, being no more than $\frac{1}{8}$ in. out of square across the width of the specimen.

9. Calibration and Standardization

9.1 Calibrations of flatness, levelness, and parallelism as described in 9.2 – 9.4 shall be performed before running the test.

9.2 The flatness of the floor and table shall each be verified using a straightedge at least 50 in. long. At no point shall the table top or floor deviate more than 0.20 in. from the surface of the straightedge. Evaluate the flatness of the floor in the area where the sag is measured, from the edge of the table to the edge of the sample.

9.3 A spirit level, at least 50 in. long shall be used to verify that the table and floor are each level. Over the length of the spirit level, a deviation of less than 0.2 in. is considered insignificant.

9.4 After verifying the flatness and level of both the table and the floor, verify them in combination. Place a straightedge 96 to 100 in. long on the table so that 50 in. of the straightedge extends perpendicular over the table edge. Place the weight from 7.2 on the table end of the straightedge to hold it flat. Measure the distance from the straightedge to the floor at two points: at the unsupported end of the straightedge and immediately adjacent to the table edge. These two measurements shall not differ by more than 0.20 in.

9.5 If necessary to correct the level of the table, shims can be permanently attached to the bottom of the table legs.

10. Conditioning

10.1 Prior to testing, condition the test specimen for a minimum of 24 h at a temperature of $73.4^{\circ}\text{F} \pm 3.6$ ($20^{\circ}\text{C} \pm 2$). During conditioning the specimen shall rest on a flat surface that supports the specimen over its entire length.

11. Procedure

11.1 Select one (unnotched) end of the specimen to be the end that will extend off the table. Label this end of the specimen to avoid subsequent confusion about which end is to be unsupported. Using a tape measure, make a mark $50 \pm \frac{1}{16}$ in. from this unsupported end.

11.2 Place the specimen face up (the face is the side that is exposed after installation) on the table so that the specimen is perpendicular to the edge of the table (parallel to the perpendicular line drawn on the table) and with the 50 in. mark directly over the table edge.

11.3 Place the weight described in 7.2 on the supported end of the specimen (the end on the table). The edge of the weight furthest from the supported end shall be 6 ± 0.5 in. from the supported end (see Fig. 1). The weight shall cover the entire width of the specimen. After positioning the weight verify once again that the position of the specimen is as described in 11.2. The panel shall be allowed to bow upwards between the weight and the table edge.

11.4 Three minutes \pm 15 seconds after positioning the sample as described above, measure the distance from the unsupported end of the specimen to the floor. Make one measurement at each edge of the specimen. Each measurement shall be from the floor to a portion on the panel cross-section that is in contact with the table. These measurements shall be made with a rigid ruler maintained perpendicular to the floor, to the nearest $\frac{1}{16}$ in. Average these two values and record this average as the "mean specimen height."

11.5 Run three replicates and average the three "mean specimen height" values.

11.6 Use the ruler to measure to the nearest $\frac{1}{16}$ in. the distance from the table top to the floor, adjacent to the edge where the specimen extends. Record this "table height" value.

12. Calculation or Interpretation of Results

12.1 Subtract the average of the three "mean specimen heights" from the "table height" to obtain the "sample deflection."

12.2 Subtract the "sample deflection" from 100 to obtain the "rigidity index." Report the "rigidity index" and all individual measurements, along with an identification of the sample.

NOTE 2—The "rigidity index" expresses the sample sag relative to the sample length. The "rigidity index" is defined as 100 minus the deflection value, divided by the sample length, expressed as a percentage. Due to the sample length designated in this procedure, the "percent rigidity" simplifies to 100 minus the deflection value in inches, as shown below.

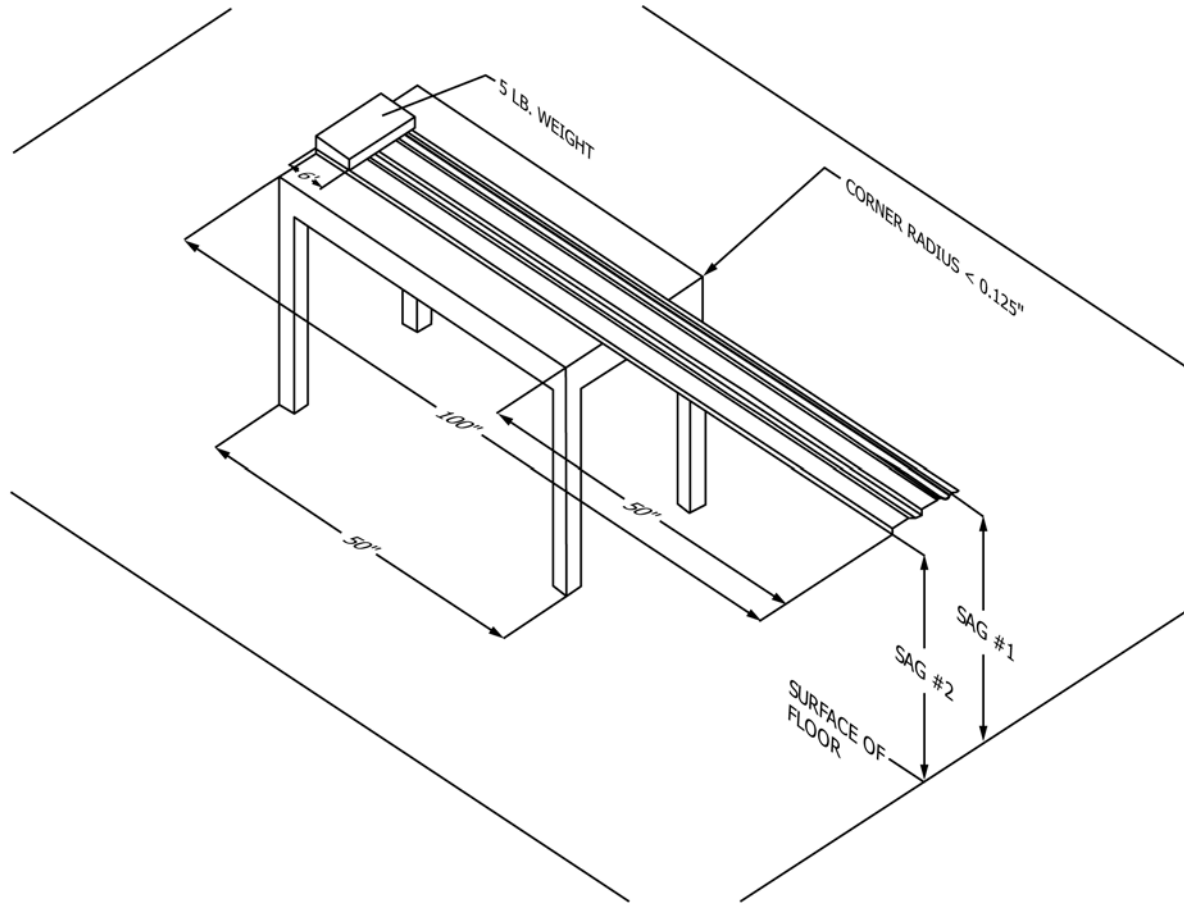

FIG. 1 Testing Apparatus for Rigidity of Vinyl Siding

$$100 \times \frac{(100 - \text{deflection})}{\text{specimen length}} = 100 \times \frac{(100 - \text{deflection})}{100} = 100 - \text{deflection}$$

13. Report

- 13.1 The report shall include the following:
 - 13.1.1 Complete identification of sample tested,
 - 13.1.2 Mean specimen height values and their average,
 - 13.1.3 Table height,
 - 13.1.4 Sample deflection, and
 - 13.1.5 Rigidity index.

14. Precision and Bias

14.1 **Table 1** is based on an interlaboratory study conducted in 2000 involving 15 materials tested by seven laboratories. Similar commercial materials were received from several major siding producers, and coded by the organizing lab. All materials were tested by each laboratory in an as received condition.

14.1.1 In **Table 1** for the materials indicated, mean values were derived from triplicate determinations.

14.1.2 *Sr* is the within laboratory standard deviation of the mean. *r* is the within laboratory critical interval between two test results and $r = 2.83 Sr$.

TABLE 1 Precision and Bias Data

Materials	Mean	<i>Sr</i>	<i>SR</i>	<i>r</i>	<i>R</i>
D4DL1	91.68	0.44	0.74	1.25	2.09
D5H1	93.51	0.29	0.73	0.82	2.07
D5H2	85.84	0.74	0.90	2.09	2.55
D5V1	94.08	0.67	0.89	1.90	2.52
D4DL2	92.16	0.29	0.79	0.82	2.24
D5H3	93.34	0.48	0.84	1.36	2.38
D5V2	86.32	0.28	0.94	0.79	2.66
D4DL2	90.85	0.26	0.80	0.74	2.26
D4DL3	96.12	0.10	0.63	0.28	1.78
D4DL4	92.85	0.10	0.75	0.28	2.12
D5H3	87.71	0.84	1.25	2.38	3.54
D5V3	91.07	0.20	0.68	0.57	1.92
D4DL2	91.48	0.15	0.71	0.42	2.01
D5H3	96.01	0.38	0.71	1.08	2.01
D5L1	91.17	0.19	0.99	0.54	2.80

14.1.3 *SR* is the between laboratory standard deviation of the mean. *R* is the between laboratory critical interval between test results and $R = 2.83 SR$.

NOTE 3—The explanations of *r* and *R* are only intended to present a meaningful way of considering the approximate precision of this test method. The data in **Table 1** should not be applied to acceptance of rejection of materials as these data apply only to the materials tested in the round robin and may not be representative of other lots or formulations. Users of this test method should apply the principles outlined in E691 to generate data specific to their materials and laboratory.

14.2 *Bias*—Since no absolute test method exists for comparison, no bias statement can be presented for this test method.

15. Keywords

15.1 PVC siding; rigidity; rigidity index

SUMMARY OF CHANGES

Committee D20 has identified the location of selected changes to this standard since the last issue (D6777 - 02(2010)^{e1}) that may impact the use of this standard. (May 1, 2016)

(1) Modified 1.2, 5.1, and 6.1, 9.1, and 9.2 for clarity.

ASTM International takes no position respecting the validity of any patent rights asserted in connection with any item mentioned in this standard. Users of this standard are expressly advised that determination of the validity of any such patent rights, and the risk of infringement of such rights, are entirely their own responsibility.

This standard is subject to revision at any time by the responsible technical committee and must be reviewed every five years and if not revised, either reapproved or withdrawn. Your comments are invited either for revision of this standard or for additional standards and should be addressed to ASTM International Headquarters. Your comments will receive careful consideration at a meeting of the responsible technical committee, which you may attend. If you feel that your comments have not received a fair hearing you should make your views known to the ASTM Committee on Standards, at the address shown below.

This standard is copyrighted by ASTM International, 100 Barr Harbor Drive, PO Box C700, West Conshohocken, PA 19428-2959, United States. Individual reprints (single or multiple copies) of this standard may be obtained by contacting ASTM at the above address or at 610-832-9585 (phone), 610-832-9555 (fax), or service@astm.org (e-mail); or through the ASTM website (www.astm.org). Permission rights to photocopy the standard may also be secured from the Copyright Clearance Center, 222 Rosewood Drive, Danvers, MA 01923, Tel: (978) 646-2600; <http://www.copyright.com/>