



Standard Test Method for Measuring Stiffness and Apparent Modulus of Soil and Soil-Aggregate In-Place by Electro-Mechanical Method¹

This standard is issued under the fixed designation D6758; the number immediately following the designation indicates the year of original adoption or, in the case of revision, the year of last revision. A number in parentheses indicates the year of last reapproval. A superscript epsilon (ϵ) indicates an editorial change since the last revision or reapproval.

1. Scope

1.1 This test method covers the measurement by electro-mechanical means of the in-place stiffness of soil or soil-aggregate mixtures so as to determine a Young's modulus based on certain assumptions. The apparatus and procedure provide a fairly rapid means of testing so as to minimize interference and delay of construction. The test procedure is intended for evaluating the stiffness or modulus of materials used in earthworks and roadworks. Rapid in-place stiffness testing supports U.S. federal and state efforts to specify the in-place performance of construction materials based on modulus. Results obtained from this method are applicable to the evaluation of granular cohesionless materials. They are also applicable to the evaluation of silty and clayey materials with more than 20 % fines that are not subject to a change in moisture content. If the silty and clayey material experiences a change in moisture content, then moisture content shall be taken into account if the results of this method are to be applicable. The stiffness measured with this method is influenced by boundary conditions, specifically the support offered by underlying layers as well as the thickness and modulus of the layer being tested. Since this method approximates the layer(s) being evaluated as a half-space, then the modulus measured is also approximate.

1.2 The stiffness, in force per unit displacement, is determined by imparting a small measured force to the surface of the ground, measuring the resulting surface velocity and calculating the stiffness. This is done over a frequency range and the results are averaged.

1.3 The values stated in SI units are to be regarded as the standard. The inch-pound units equivalents may be approximate.

1.4 *This standard does not purport to address all of the safety concerns, if any, associated with its use. It is the responsibility of the user of this standard to establish appro-*

priate safety and health practices and determine the applicability of regulatory limitations prior to use.

NOTE 1—Notwithstanding the statements on precision and bias contained in this test method; the precision of this test method is dependent on the competence of the personnel performing it, and the suitability of the equipment and facilities used. Agencies that meet the criteria of Practice D3740 are generally considered capable of competent and objective testing. Users of this test method are cautioned that compliance with Practice D3740 does not in itself assure reliable testing. Reliable testing depends on many factors; Practice D3740 provides a means of evaluating some of those factors.

2. Referenced Documents

2.1 ASTM Standards:²

- D653 Terminology Relating to Soil, Rock, and Contained Fluids
- D698 Test Methods for Laboratory Compaction Characteristics of Soil Using Standard Effort (12 400 ft-lbf/ft³ (600 kN-m/m³))
- D1557 Test Methods for Laboratory Compaction Characteristics of Soil Using Modified Effort (56,000 ft-lbf/ft³ (2,700 kN-m/m³))
- D2216 Test Methods for Laboratory Determination of Water (Moisture) Content of Soil and Rock by Mass
- D3740 Practice for Minimum Requirements for Agencies Engaged in Testing and/or Inspection of Soil and Rock as Used in Engineering Design and Construction
- D4220 Practices for Preserving and Transporting Soil Samples
- D4643 Test Method for Determination of Water (Moisture) Content of Soil by Microwave Oven Heating
- D4944 Test Method for Field Determination of Water (Moisture) Content of Soil by the Calcium Carbide Gas Pressure Tester
- D4959 Test Method for Determination of Water (Moisture) Content of Soil By Direct Heating

3. Terminology

3.1 Definitions:

² For referenced ASTM standards, visit the ASTM website, www.astm.org, or contact ASTM Customer Service at service@astm.org. For *Annual Book of ASTM Standards* volume information, refer to the standard's Document Summary page on the ASTM website.

¹ This test method is under the jurisdiction of ASTM Committee D18 on Soil and Rock and is the direct responsibility of Subcommittee D18.08 on Special and Construction Control Tests.

Current edition approved Jan. 1, 2008. Published February 2008. Originally approved in 2002. Last previous edition approved in 2002 as D6758 – 02. DOI: 10.1520/D6758-08.

3.1.1 For common definitions of terms in this standard, refer to Terminology **D653**.

3.1.2 *stiffness, n*—the ratio of change of force to the corresponding change in translational deflection of an elastic element. **D653**

3.1.3 *Young's modulus, n*—the ratio of the increase in stress on a test specimen to the resulting increase in strain under constant traverse stress limited to materials having a linear stress-strain relationship over a range of loading. Also called elastic modulus. **D653**

3.1.4 *Poisson's ratio, n*—the ratio between linear strain changes perpendicular to and in the direction of a given uniaxial stress change. **D653**

3.2 Definitions of Terms Specific to This Standard:

3.2.1 *shear modulus, (G), n*—as equation:

$$G = \frac{E}{2(1+\nu)} \quad (1)$$

where:

G = shear modulus, MPa (kpsi),
 E = Young's modulus, MPa (kpsi), and
 ν = Poisson's ratio.

3.2.2 *foot, n*—that part of the apparatus which contacts the ground and imparts force to it.

3.2.3 *footprint, n*—the annular ring imprint left on the ground by the foot of the apparatus.

3.2.4 *non-destructive, adj*—a condition that does not impair future usefulness and serviceability of a layer of soil or soil-aggregate mixture in order to measure, evaluate or assess its physical properties.

3.2.5 *seating the foot, v*—the process of placing the apparatus on the ground such that the desired footprint is achieved.

3.2.6 *site, n*—the general area where measurements are to be made.

3.2.7 *test location, n*—a specific location on the ground where a measurement is made.

4. Significance and Use

4.1 The apparatus and procedure described provides a means for measurement of the stiffness of a layer of soil or soil-aggregate mixture from which a Young's modulus may be determined for an assumed Poisson's ratio. Low strain cyclic loading is applied by the apparatus about a static load that is consistent with highway applications **(1)**.

4.2 This method is useful as a non-destructive method for monitoring or controlling compaction so as to avoid under-compaction, over-compaction or wasted effort. Through an understanding of how stiffness relates to density for a particular material, moisture content and compaction procedure, the stiffness achieved can be related to % compaction in connection with density based compaction control or specifications, for example, to meet the requirements of Method **D698** using standard effort or Method **D1557** using modified effort.

4.2.1 This method applies to silty and clayey materials containing greater than 20 % fines. In such cases, the relationship between stiffness and dry density or dry unit weight is

sensitive to the water content. Water contents should be determined by use of: Test Method **D2216**, **D4643**, or **D4959**. If the determination cannot be made immediately at the time of the stiffness measurements, then soil samples shall be preserved and transported in accordance with Practice **D4220**, Section 8, Groups B, C, or D soils.

4.2.2 This method is useful in the construction of road bases or earthworks, including the installation of buried pipe **(2)**.

4.2.3 The rapid, non-penetrating nature of this method is suited to production testing, for example, it provides a means of testing that does not necessarily interfere with or delay construction.

4.3 This method is suitable for mitigating the risk of pavement failure. By assuring the relative uniformity of highway subbase, subgrade and base stiffnesses, stresses on the pavement is more uniformly distributed. In this way the life of a pavement is extended and repairs minimized.

4.4 This method is suitable for determining when the surface of a soil or soil-aggregate structure is capable of supporting design loads. This is useful for stabilized fills where the material hardens (stiffens) over time without measurable changes in density or moisture content.

4.5 This test method is suitable for the in-place determination of a Young's and a shear modulus of soil and soil-aggregate mixtures **(3, 4)**. Stiffness, as measured by this method, is related to modulus **(5)** from an assumption of Poisson's ratio and from the radius of the foot of the apparatus as follows:

$$K_{gr} \approx \frac{1.77RE}{(1-\nu^2)} \approx \frac{3.54RG}{(1-\nu)} \quad (2)$$

where:

K_{gr} = stiffness of the ground layer being measured, MN/m (klbf/in.),
 R = outside radius of the apparatus' foot, m (in.),
 ν = Poisson's ratio,
 E = Young's modulus, MPa (kpsi), and
 G = Shear modulus, MPa (kpsi).

4.5.1 The stiffness and modulus of silty and clayey materials will change with moisture content and can possibly result in hydro-compaction collapse, loss of bearing capacity or loss of effective shear strength. In addition, for silty and clayey materials with significant fines content, higher stiffness does not necessarily assure adequate compaction **(6)**.

5. Apparatus

5.1 *Stiffness Gauge*—An electro-mechanical instrument, such as that illustrated in **Fig. 1**, capable of being seated on the surface of the material under test and which provides a meaningful and measurable stress level and a means of determining force and displacement.

5.2 *Moist Sand*—A supply of clean, fine sand passing a No. 30 (600- μ m) sieve, that is sufficiently moist to clump in the palm of the hand. This is used to assist the seating of the rigid foot on hard and rough ground surfaces or at anytime when additional assistance in seating is required.

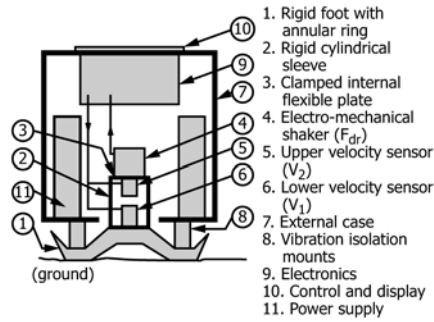

FIG. 1 Possible Apparatus Schematic

5.3 *Principle of Operation*—The force applied by the shaker and transferred to the ground, as illustrated in Fig. 1, is measured and calculated by differential displacement across the internal flexible plate as follows:

$$F_{dr} = K_{flex}(X_2 - X_1) + \omega^2 m_{int} X_1 \quad (3)$$

where:

- F_{dr} = force applied by the shaker, N (lbf),
- K_{flex} = stiffness of the flexible plate, MN/m (klbf/in.),
- X_2 = displacement at the flexible plate, m (in.),
- X_1 = displacement at the rigid foot, m (in.),
- ω = $2\pi f$, where f is frequency, Hz, and
- m_{int} = mass of the internal components attached to the rigid foot and the foot itself, kg (lb).

At the frequencies of operation, the ground-input impedance is dominantly stiffness controlled.

$$K_{gr} = \frac{F_{dr}}{X_1} \quad (4)$$

where:

- K_{gr} = stiffness of the ground layer being measured, MN/m (klbf/in).

By substituting Eq 3 for F_{dr} in Eq 4, averaging over the operating frequencies and substituting velocity, V , for displacement, X , since the units cancel each other, the ground stiffness is calculated as follows:

$$\bar{K}_{gr} = K_{flex} \frac{\sum_1^n \left(\frac{X_2 - X_1}{X_1} \right) + \frac{\sum_1^n \omega^2}{n} m_{int}}{n} = K_{flex} \frac{\sum_1^n \left(\frac{V_2 - V_1}{V_1} \right) + \frac{\sum_1^n \omega^2}{n} m_{int}}{n} \quad (5)$$

where:

- n = number of test frequencies used in the apparatus,
- V_2 = velocity at the flexible plate, m/s (ft/s), and
- V_1 = velocity at the rigid foot, m/s (ft/s).

This approach avoids the need for a non-moving reference for ground displacement and permits the accurate measurement of small displacements. It also assumes the following conditions.

5.3.1 A significant number of discrete measurement frequencies (for example, ≥ 20) should be above the typical operating frequencies of construction equipment and below the frequencies where ground impedance is no longer stiffness controlled (for example, 100 to 200 Hz).

5.3.2 So as to not interfere with or delay construction, a sufficiently short period of time should be required for a single measurement, for example, < 2 min.

5.3.3 The depth of measurement is on the order of twice the foot outside diameter. The depth of measurement may be confirmed by measuring the stiffness of a layer of material in a confined bin per this method and comparing it to the stiffness of the layer as calculated from the measured void ratio, the estimated mean effective stress under the apparatus' foot and the estimated Poisson's ratio (7).

5.3.4 The apparatus should be used in a manner such that construction site noise and vibration do not interfere with the test. The apparatus should be immune to construction noise and vibration as much as is practical.

5.3.5 There should be an apparatus weight sufficient to produce a meaningful stress on the ground, for example, 20.6 to 27.6 kPa (3 to 5 psi).

5.3.6 The measurement should not densify the material being measured or otherwise change its material properties. Periodic, repeated measurements (at least 10) at selected locations where individual results are about equally distributed about the mean of all results will indicate that the measurement has not densified the material.

5.3.7 The apparatus should be of sufficient accuracy to achieve the required precision and bias.

6. Calibration

6.1 Follow the recommendations of the apparatus manufacturer. Calibration via the force-to-displacement produced by moving a mass is suggested, as it will provide an absolute reference for stiffness measurements. This may be done by rigidly attaching a mass of known value to the foot of the apparatus and attaching the mass to isolation mounts with a high frequency cut-off of approximately 5 Hz. A measurement of stiffness in this configuration should agree with the following equation within $\pm 1\%$.

$$K_{eff} = \frac{\sum_1^n M(\omega)^2}{n} \quad (6)$$

where:

- K_{eff} = effective stiffness offered by the moving mass, MN/m (klbf/in.),
- M = value of the moving mass, kg (lb),
- ω = $2\pi f$, where f is frequency, Hz, and
- n = the number of frequencies used in the apparatus.

6.2 Calibration of the apparatus is suggested every 12 months.

6.3 When any stiffness measurement is in doubt, a field check of the calibration may be needed. A check via the force-to-displacement produced by moving a known mass is suggested, as it will provide an approximate reference for stiffness measurements (see 6.1). Note that field conditions may not allow the precision of a laboratory calibration and so an appropriate tolerance should be assigned to the check (for example, $\pm 5\%$ relative to the value of stiffness expected).

7. Procedure

7.1 Guidelines for Seating the Foot:

7.1.1 Before seating the foot, lightly brush any loose material away from the test location. The surface need not be leveled if the gauge can stand on its own. If leveling is required, scraping the surface with a square point shovel is sufficient.

7.1.2 To provide for consistent stress on the ground for each measurement, at least 60 % of the foot's annular ring surface must seat or contact the ground. The amount of surface contact is visibly estimated from the footprint left by the foot when the apparatus is lifted off the ground after the measurement is taken.

7.1.3 If the footprint cannot be readily seen, assist the seating of the foot as described in 7.1.4.

7.1.4 If the requirement of 7.1.2 cannot be met because of a rough or irregular ground surface or if the surface is hard and smooth, apply a thin layer of clean, moist sand about 3.0 to 6.0 mm ($\frac{1}{8}$ to $\frac{1}{4}$ in.) thick, on the test location. Pat down firmly. Seat the foot on top of the sand.

7.1.5 Practice in seating the foot is suggested as described above at each site prior to any actual measurements or each time ground surface conditions change. In addition, follow the manufacturer's recommendations as appropriate.

7.2 Stiffness Measurement:

7.2.1 Assure that the foot is clean and free of soil and other debris.

7.2.2 Turn on the apparatus.

7.2.3 Seat the foot per the directions of 7.1.

7.2.4 Assure that the external case of the apparatus does not come into contact with a trench wall, pipe or any other object.

7.2.5 Initiate the measurement. The apparatus should dwell at each frequency. The shaker will impart a force to the foot of the apparatus (see Fig. 1). The stiffness is calculated at each frequency by measuring and comparing the velocities from the two sensors (see 5.3). When the stiffness is calculated at all frequencies, the average stiffness over frequency is calculated and displayed in MN/m or klb/in. Using the radius of the foot and a user selected value of Poisson's ratio, a Young's modulus may be calculated and displayed (see 4.5).

NOTE 2—Section 4.5 with its accompanying equation by Poulos and Davis (3) provides a means to determine a modulus using a force applied to an annular ring.

7.2.6 Remove the apparatus from the test location and inspect the footprint per the guidelines of 7.1. If contact is not adequate, prepare the surface with sand, per 7.1.3, and redo the

measurement. If contact was adequate, record the displayed values of stiffness and, if used, the user selected value of Poisson's ratio and the calculated modulus.

7.3 Water Content Measurement:

7.3.1 If this method is applied to silty or clayey materials containing greater than 20 % fines, then a water content measurement in companion with stiffness is recommended.

7.3.2 Water content should be determined by test methods D2216, D4643, D4944, or D4959.

7.3.3 A water content measurement should be made on a disturbed sample. The sample should be taken from the approximate center of where the stiffness measurement was taken. The weight of the sample will depend on the maximum particle size as specified by the Standard Test Method used. The sample should be taken from a minimum depth of 10 cm (~ 4 in.) to an optimum depth of 20 (~ 8 in.).

7.3.4 A sample for a water content measurement should be taken at least every 152 m (~ 500 ft) along the material length being measured for stiffness.

7.3.5 Depending on the material, stiffness will be more or less dependent on the water content. It is up to the user to determine and use the appropriate relationship between stiffness and water content to suit the needs of the specific application. This method is intended to define how to perform a precise stiffness measurement, not interpret that measurement relative to an application.

8. Report

8.1 The report shall contain the following as a minimum:

8.1.1 At least a visual classification of the soils and soil mixtures as well as a visual description of the same and the test conditions.

8.1.2 A sketch showing and numerically recording the position of test locations relative to site stations.

8.1.3 All stiffness measurements and any modulus determinations with its assumed Poisson's ratio identified by test location, time and date. Stiffness data shall be rounded and recorded to one decimal place (that is, 14.3 MN/m).

8.1.4 The make(s), model(s) and serial number(s) of the test equipment used.

8.1.5 The name(s) of the operator(s).

8.1.6 Identification of the project, the site, test locations and depth of measure.

8.1.7 Water content in percent if measured.

9. Precision and Bias

9.1 Precision:

9.1.1 Data is continuing to be collected for the determination of this method's precision. The Subcommittee D18.08 is seeking any data from the users of this test method that might be used to make a limited statement on precision.

9.1.2 In this standard, precision is defined as the coefficient of variation of a set of repeated measurements as follows:

$$P = \frac{\sigma}{S} \cdot 100 \quad (7)$$

where:

P = instrument precision in %,

\bar{S} = the average stiffness of measurements made at one test location, MN/m (klbf/in), and
 σ = one standard deviation of the stiffness.

9.1.3 Typically, the precision of a stiffness measurement per this method is represented by a coefficient of variation of 4 %. Repeated measurements for two apparatus on the same location typically have a coefficient of variation of 5.7 %. This is an estimate based in limited field measurements. A comprehensive evaluation of precision continues.

9.1.4 The precision of any given measurement depends on the surface conditions of the layer being measured and how well the foot of the apparatus is seated.

9.2 *Bias:*

9.2.1 The stiffness reference for this test method is a moving mass as defined in Section 6.

9.2.2 The bias of a stiffness measurement per this method is a coefficient of variation of ≤ 1 %.

10. Keywords

10.1 compaction control; in-place modulus; in-place stiffness; in-situ test; non-destructive; production testing; shear modulus; soil stiffness test; stiffness gauge; Young's modulus

REFERENCES

- (1) Nelson, C. R. and Sondag, M., *Comparison of the Humboldt GeoGauge™ With In-Place Quasi-Static Plate Load Tests*, December 1999, CNA Consulting Engineers, Minneapolis, MN. CNA Consulting Engineers, 2800 University Avenue SE, Minneapolis, Minnesota 55414.
- (2) Hill, James J., Kurdziel, John M., Nelson, Charles R., Nystrom, James A. and Sondag, Mike, 1998, MnDOT Overload Field Tests of Standard and SIDD RCP Installations: MnDOT Report, Minnesota Department of Transportation.
- (3) Chen, D.H., Wu, W., Rong, H. and Arrelano, M., 1999, "Evaluation of In-Situ Resilient Modulus Testing Techniques, Recent Advances in the Characterization of Transportation Geo-Materials," ASCE 0-7844-0437-2, 62 pp., E. Tutumluer and A.Y. Papagiannakis, Eds., American Society of Civil Engineers, Geoinstitute, Reston, VA.
- (4) Siekmeier, J. A., Young, D. and Beberg, D., 1999, "Comparison of the Dynamic Cone Penetrometer and Other Tests During Subgrade and Granular Base Characterization in Minnesota," *Nondestructive Testing of Pavements and Backcalculation of Moduli: Third Volume, ASTM STP 1375*, S. D. Tayabji and E. O. Lukanen, Eds., American Society for Testing and Materials, West Conshohocken, PA.
- (5) Poulos, H.G., and Davis, E.H., *Elastic Solutions For Soil & Rock Mechanics*, John Wiley & Sons, Inc., New York, New York, 1974, pp. 167-168.
- (6) Seed, H. B. and Chan, C. K., (1959), "Structure and Strength Characteristics of Compacted Clays," *Journal of the Soil Mechanics and Foundations Division, ASCE*, Vol. 85, No. SM5, October, Fig. 6.
- (7) Lenke, L. R., Grush, M. and McKeen, R. G., *Evaluation of the Humboldt GeoGauge™ on Dry Cohesionless Silica Sand in a Cubical Test Bin*, January 2000, University of New Mexico. ATR Institute, University of New Mexico, Albuquerque, NM 87131.

ASTM International takes no position respecting the validity of any patent rights asserted in connection with any item mentioned in this standard. Users of this standard are expressly advised that determination of the validity of any such patent rights, and the risk of infringement of such rights, are entirely their own responsibility.

This standard is subject to revision at any time by the responsible technical committee and must be reviewed every five years and if not revised, either reapproved or withdrawn. Your comments are invited either for revision of this standard or for additional standards and should be addressed to ASTM International Headquarters. Your comments will receive careful consideration at a meeting of the responsible technical committee, which you may attend. If you feel that your comments have not received a fair hearing you should make your views known to the ASTM Committee on Standards, at the address shown below.

This standard is copyrighted by ASTM International, 100 Barr Harbor Drive, PO Box C700, West Conshohocken, PA 19428-2959, United States. Individual reprints (single or multiple copies) of this standard may be obtained by contacting ASTM at the above address or at 610-832-9585 (phone), 610-832-9555 (fax), or service@astm.org (e-mail); or through the ASTM website (www.astm.org). Permission rights to photocopy the standard may also be secured from the Copyright Clearance Center, 222 Rosewood Drive, Danvers, MA 01923, Tel: (978) 646-2600; http://www.copyright.com/