



Standard Guide for Installation of Direct Push Groundwater Monitoring Wells¹

This standard is issued under the fixed designation D6724/D6724M; the number immediately following the designation indicates the year of original adoption or, in the case of revision, the year of last revision. A number in parentheses indicates the year of last reapproval. A superscript epsilon (ϵ) indicates an editorial change since the last revision or reapproval.

1. Scope*

1.1 This guide describes various direct push groundwater monitoring wells and provides guidance on their selection and installation for obtaining representative groundwater samples and monitoring water table elevations. Direct push wells are used extensively for monitoring groundwater quality in unconsolidated formations. This guide also includes discussion of some groundwater sampling devices which can be permanently emplaced as monitoring wells.

1.2 This guide does not address the single event sampling of groundwater using direct push water samplers as presented in Guide [D6001](#). The methods in this guide are often used with other tests such as direct push soil sampling (Guide [D6282](#)) and the cone penetrometer test (Guide [D6067](#)). The guide does not address the installation of monitoring wells by rotary drilling or sonic drilling methods such as those presented in Practice [D5092](#). Techniques for obtaining groundwater samples from monitoring wells are covered in Guides [D4448](#), [D7929](#), and Practice [D6771](#). Practice [D6725](#) addresses direct push wells using pre-packed screens.

1.3 The installation of direct push groundwater monitoring wells is limited to unconsolidated soils and sediments including clays, silts, sands, and some gravels and cobbles. Penetration may be limited, or damage may occur to equipment, in certain subsurface conditions; some of which are discussed in [5.5](#). Information in this guide is limited to groundwater monitoring in the saturated zone.

1.4 The values stated in either inch-pound units or SI units presented in brackets are to be regarded separately as standard. The values stated in each system may not be exact equivalents; therefore, each system shall be used independently of the other. Combining values from the two systems may result in non-conformance with the standard.

1.5 All observed and calculated values shall conform to the guidelines for significant digits and rounding established in Practice [D6026](#), unless superseded by this standard.

1.6 This guide offers an organized collection of information or a series of options and does not recommend a specific course of action. This document cannot replace education or experience and should be used in conjunction with professional judgement. Not all aspects of this guide may be applicable in all circumstances. This ASTM standard is not intended to represent or replace the standard of care by which the adequacy of a given professional service must be judged, nor should this document be applied without consideration of a project's many unique aspects. The word "Standard" in the title of this document means only that the document has been approved through the ASTM consensus process.

1.6.1 This guide does not purport to comprehensively address all of the methods and issues associated with monitoring well installation. Users should seek input from qualified professionals for the selection of proper equipment and methods that would be the most successful for their site conditions. Other methods may be available for monitoring well installation, and qualified professionals should have flexibility to exercise judgement concerning alternatives not covered in this guide. The practice described in this guide is current at the time of issue; however, new, alternative, and innovative methods may become available prior to revisions. Therefore, users should consult with manufacturers or producers prior to specifying program requirements.

1.7 *This standard does not purport to address all of the safety concerns, if any, associated with its use. It is the responsibility of the user of this standard to establish appropriate safety and health practices and determine the applicability of regulatory requirements prior to use.*

2. Referenced Documents

2.1 ASTM Standards:²

- [D653 Terminology Relating to Soil, Rock, and Contained Fluids](#)
- [D3740 Practice for Minimum Requirements for Agencies Engaged in Testing and/or Inspection of Soil and Rock as Used in Engineering Design and Construction](#)
- [D4448 Guide for Sampling Ground-Water Monitoring Wells](#)

¹ This guide is under the jurisdiction of ASTM Committee [D18](#) on Soil and Rock and is the direct responsibility of Subcommittee [D18.21](#) on Groundwater and Vadose Zone Investigations.

Current edition approved July 1, 2016. Published July 2016. Originally approved in 2001. Last previous edition approved in 2010 as [D6724-04\(2010\)](#). DOI: 10.1520/D6724_D6724M-16.

² For referenced ASTM standards, visit the ASTM website, www.astm.org, or contact ASTM Customer Service at service@astm.org. For Annual Book of ASTM Standards volume information, refer to the standard's Document Summary page on the ASTM website.

*A Summary of Changes section appears at the end of this standard

D4750 Test Method for Determining Subsurface Liquid Levels in a Borehole or Monitoring Well (Observation Well) (Withdrawn 2010)³

D5088 Practice for Decontamination of Field Equipment Used at Waste Sites

D5092 Practice for Design and Installation of Groundwater Monitoring Wells

D5254 Practice for Minimum Set of Data Elements to Identify a Ground-Water Site

D5299 Guide for Decommissioning of Groundwater Wells, Vadose Zone Monitoring Devices, Boreholes, and Other Devices for Environmental Activities

D5434 Guide for Field Logging of Subsurface Explorations of Soil and Rock

D5474 Guide for Selection of Data Elements for Groundwater Investigations

D5521 Guide for Development of Groundwater Monitoring Wells in Granular Aquifers

D5730 Guide for Site Characterization for Environmental Purposes With Emphasis on Soil, Rock, the Vadose Zone and Groundwater (Withdrawn 2013)³

D5978 Guide for Maintenance and Rehabilitation of Groundwater Monitoring Wells

D6001 Guide for Direct-Push Groundwater Sampling for Environmental Site Characterization

D6026 Practice for Using Significant Digits in Geotechnical Data

D6067 Practice for Using the Electronic Piezocone Penetrometer Tests for Environmental Site Characterization

D6282 Guide for Direct Push Soil Sampling for Environmental Site Characterizations

D6286 Guide for Selection of Drilling Methods for Environmental Site Characterization

D6452 Guide for Purging Methods for Wells Used for Groundwater Quality Investigations

D6564 Guide for Field Filtration of Groundwater Samples

D6634 Guide for Selection of Purging and Sampling Devices for Groundwater Monitoring Wells

D6725 Practice for Direct Push Installation of Prepacked Screen Monitoring Wells in Unconsolidated Aquifers

D6771 Practice for Low-Flow Purging and Sampling for Wells and Devices Used for Ground-Water Quality Investigations (Withdrawn 2011)³

D6914 Practice for Sonic Drilling for Site Characterization and the Installation of Subsurface Monitoring Devices

D7242 Practice for Field Pneumatic Slug (Instantaneous Change in Head) Tests to Determine Hydraulic Properties of Aquifers with Direct Push Groundwater Samplers

D7352 Practice for Direct Push Technology for Volatile Contaminant Logging with the Membrane Interface Probe (MIP)

D7929 Guide for Selection of Passive Techniques for Sampling Groundwater Monitoring Wells

3. Terminology

3.1 *Definitions*—For common definitions of terms in this standard, refer to Terminology D653.

3.2 *Definitions of Terms Specific to This Standard:*

3.2.1 *dual tube systems, n*—a system whereby inner and outer tubes are advanced independently or simultaneously into the subsurface strata.

3.2.1.1 *Discussion*—The outer casing tube is used for borehole stabilization. The inner tube for is used sampler recovery and insertion of other devices. In Practice D6282, direct push soil sampling the dual tube system takes soil samples with a sampler fixed to the inner rods.

4. Summary of Guide

4.1 This guide provides information to be used by experienced groundwater professionals for exploration of the subsurface and ambient groundwater conditions.

4.2 This guide outlines a variety of field methods for installing direct push groundwater monitoring wells. Installation methods include: (1) soil probing using combinations of dynamic (percussion or vibratory) driving with, or without, additions of static (constant) force; (2) static force from the surface using hydraulic penetrometer or drilling equipment; and (3) incremental drilling combined with direct push methods. Methods for installation of annular seals and annular grouts are also discussed as well as abandonment grouting.

4.3 This guide addresses considerations for selection and use of direct push well systems and installation techniques that may be classified into two main categories; exposed screen techniques and protected screen techniques. In exposed screen techniques, the screened casing may serve as the drive rod, or may surround a drive rod that is removed following installation. In protected screen techniques, the well may be advanced along with a protective outer casing, or may be lowered into a driven casing that is subsequently removed. Alternatively, the screen, riser, and a retractable shield may be driven simultaneously and all remain in the ground.

4.4 The interval to be tested is determined in advance by prior exploration, or by soil or water sampling during direct push driving. A screen section, either protected or unprotected, is connected to riser pipes and either driven on the outside of, or placed inside of direct push rods. With some monitoring well designs, it may be necessary to add sand pack and seals to isolate the screened test zone as the rods are retracted. The top of the installation is usually completed in a manner consistent with regulatory requirements. The well can be developed to remove mobile sediments. Water levels can be measured, and water samples are taken as required in the sampling plan.

5. Significance and Use

5.1 The direct push ground method is a rapid and economical procedure for installing groundwater monitoring wells to obtain representative groundwater samples and location-specific hydrogeologic measurements. Direct push installations may offer an advantage over conventional rotary drilled

³ The last approved version of this historical standard is referenced on www.astm.org.

monitoring wells (Practice **D5092**) for groundwater explorations in unconsolidated formations because they reduce disturbance to the formation, and eliminate or minimize drill cuttings. At facilities where contaminated soils are present, this can reduce hazard exposure for operators, local personnel, and the environment, and can reduce investigative derived wastes. Additionally, smaller equipment can be used for installation, providing better access to constricted locations.

5.2 Direct push monitoring wells are typically smaller in diameter than drilled wells, thereby reducing purge water volumes, sampling time, and investigative derived wastes. Practice **D5092** monitoring wells are used when larger diameters and/or sample volumes are required, or at depths or in geologic formations to where it is difficult to install direct push wells. Direct push monitoring wells should be viable for monitoring for many years.

5.3 Prior to construction and installation of a direct push well or any other type of groundwater well the reader should consult appropriate local agencies regarding regulatory requirements for well construction. A regulatory variance may be required for installation of direct push monitoring wells.

5.4 To date, published comparison studies between drilled monitoring wells and direct push monitoring wells have shown comparability (**1-10**)⁴. However, selection of direct push monitoring wells over conventional rotary drilled wells should be based on several criteria, such as site accessibility and penetrability, stratigraphic structure, depth to groundwater, and aquifer transmissivity.

5.5 Typical penetration depths for installation of groundwater monitoring wells with direct push equipment depend on many variables. Some of the variables are the size and type of the driving system, diameter of the drive rods and monitoring well, and the resistance of the earth materials being penetrated. Some direct push systems are capable of installing groundwater monitoring wells to depths in excess of 100 ft [30 m], and larger direct push equipment can reach depths of several hundred feet. However, installation depths of 10 to 50 ft [5 to 15 m] are most common. Direct push methods cannot be used to install monitoring wells in consolidated bedrock (for example, granite, limestone, gneiss), but are intended for installation in unconsolidated materials such as clays, silts, sands, and some gravels. Additionally, deposits containing significant cobbles and boulders (for example, some glacial deposits), or strongly cemented materials (for example, caliche) are likely to hinder or prevent penetration to the desired monitoring depth.

5.6 For direct push methods to provide accurate groundwater monitoring results, precautions must be taken to ensure that cross-contamination by “smearing” or “drag-down” (that is, driving shallow contamination to deeper levels) does not occur, and that hydraulic connections between otherwise isolated water bearing strata are not created. Similar precautions as those applied during conventional rotary drilling operations (Guide **D6286**) should be followed.

⁴ The boldface numbers in parentheses refer to a list of references at the end of this standard.

5.7 There have been no conclusive comparisons of effectiveness of sealing between drilled monitoring wells and direct push monitoring wells. As with drilled monitoring wells, sealing methods must be carefully applied to be effective. Research on well sealing (**11**) has shown that bentonite seals are not effective above the water table and that if used bentonite grout requires a minimum of 20 % solids.

5.8 Selection of direct push monitoring wells versus conventional rotary drilled monitoring wells should be based on many issues. The advantages and disadvantages of the many available types of driving equipment and well systems must be considered with regard to the specific site conditions. Specific well systems and components, as well as direct push driving equipment, are described in Section 7.

5.9 *Advantages:*

5.9.1 Minimally intrusive and less disturbance of the natural formation conditions than many conventional drilling techniques.

5.9.2 Rapid and economical.

5.9.3 Smaller equipment with easier access to many locations.

5.9.4 Use of shorter screens can eliminate connections between multiple aquifers providing better vertical definition of water quality than long well screens. Shorter screens are also more effective at identifying contaminated zones in heterogeneous formation conditions.

5.9.5 Generates little or potentially no contaminated drill cuttings.

5.9.6 Less labor intensive than most conventional drilling techniques.

5.10 *Disadvantages:*

5.10.1 Cannot be used to install monitoring devices in consolidated bedrock and deposits containing significant cobbles and boulders.

5.10.2 Small diameter risers and screens limit the selection of useable down-hole equipment for purging and sampling.

5.10.3 Difficulty installing sand pack in small annular space if gravity installation of sand pack is used.

5.10.4 Difficulty installing grout in same annular space unless appropriately designed equipment is used.

NOTE 1—The quality of the result produced by this standard is dependent on the competence of the personnel performing it, and the suitability of the equipment and facilities used. Agencies that meet the criteria of Practice **D3740** are generally considered capable of competent and objective testing/sampling/inspection/etc. Users of this standard are cautioned that compliance with Practice **D3740** does not in itself assure reliable results. Reliable results depend on many factors; Practice **D3740** provides a means of evaluating some of those factors.

Practice **D3740** was developed for agencies engaged in the laboratory testing and/or inspection of soils and rock. As such, it is not totally applicable to agencies performing this field practice. However, user of this practice should recognize that the framework of Practice **D3740** is appropriate for evaluating the quality of an agency performing this practice. Currently there is no known qualifying national authority that inspects agencies that perform this practice.

6. Pre-Installation Considerations

6.1 *Site Characterization*—Successful installation of direct push groundwater monitoring wells must be preceded by appropriate site characterization activities. These activities

may include reconnaissance, research, conceptual model development, exploratory field investigations, and confirmation and re-evaluation of any existing flow models.

6.2 For the installation to be successful, it is imperative that the target aquifer be located accurately. As with any well installation, the geologic conditions must be understood and the stratigraphy must be known. Although direct push wells can monitor thinner aquifers, with more precision, they may be ineffective if incorrectly placed. In thicker aquifers, and when seeking dense non-aqueous phase liquids, screens may need to be located in the bottom of the water-bearing stratum. Wells placed without determination of nearby geologic conditions can be ineffective and possibly dangerous. Geologic investigations should look for perched aquifers and use installation methods which will avoid any cross contamination of the unit.

6.3 Environmental site characterization approaches are described in Guide [D5730](#). Proper site characterization for monitoring well placement is reviewed in Practice [D5092](#) on Monitoring Well Design.

6.3.1 *Characterization Tools*—In geologic settings amenable to the use of direct push groundwater monitoring wells, other direct push methods and tools can likely also be used to effectively characterize the site. For example, the Cone Penetrometer Test (CPT) (Guide [D6067](#)) is an effective tool for mapping stratigraphy and locating target layers. The Hydraulic Profiling tool is a method to map formation permeability and may be used to guide well placement. The membrane interface probe (Practice [D7352](#)) may be used to identify zones of volatile organic contamination to guide screen placement. Other sensors, such as electrical conductivity and optical detectors have been placed on CPT and other direct push systems. Direct push soil sampling (Guide [D6282](#)) and water sampling (Guide [D6001](#)) can be used in advance to locate strata of concern. Direct push characterization experience at a site can guide the user in well design or device selection.

6.3.2 *Sampling During Installation*—Many direct push systems can take soil or water samples as part of the well installation process. For example, two-tube systems described in direct push soil sampling Guide [D6282](#) can be used to collect soil samples while driving. When the target aquifer is reached, the well screen system can be installed in the casing. Sampling data taken prior to well installation can confirm the target stratum has been reached.

6.3.3 *Sampling Systems*—There is a wide variety of direct push groundwater sampling systems which can also be used for groundwater monitoring. Direct push water sampling Guide [D6001](#) describes exposed screen versus protected screen samplers. Guide [D6282](#) describes the differences in two-tube and single-rod direct push soil sampling systems.

6.4 *Access and Clearances*—The selection of driving equipment should consider the accessibility of the installation site. The site should be surveyed for accessibility. Utility clearances may be required. Certain driving methods are incompatible with nearby hazards (for example, flammables). Also check for overhead utility lines during the site survey.

6.5 *Well Size Selection*—Driving resistance can govern the selection of an appropriate well diameter. Driving resistance

can be evaluated by direct push testing on the site prior to well installation. Larger diameter monitoring wells may be easy to install on soft or loose ground sites. Smaller diameter monitoring wells may facilitate deeper installation on sites that are more resistant to penetration, but also present additional considerations for use as discussed below.

6.5.1 The availability of appropriate well development and sampling equipment for use in small-diameter monitoring wells may be limited. Many conventional down-hole pumps for purging and sampling are too large for use in small-diameter screens and risers. However, simple inertial pumps are robust and generally effective for developing smaller DP wells installed in coarse grained formations.

6.5.2 Small diameter monitoring wells, because they are generally less rigid than larger diameter monitoring wells, require special attention during backfilling to maintain vertical alignment. This may include the use of centralizers.

7. Direct Push Wells Systems and Components

7.1 *Drive Rod and Casing*—Rod systems can be single rods or casing tubes or dual tube systems (Practice [D6282](#)) specifically designed for direct push hammers. In some instances with single tube system the well itself may serve as the drive rod. Direct push drive rod is typically constructed of steel in threaded sections. Lengths of 5 ft [1 m] are common. The diameter selected will depend on the driving resistance of the soil and well size considerations. Consult experienced area contractors or qualified manufacturers to select the appropriate diameters for the site. Drive rods used inside of dual tube casings range from 0.5 to 1.25 in. [15 to 30 mm] in diameter. Outer drive casings of up to 4.5-in. [10 mm] diameter have been used at relatively soft or loose soil sites allowing installation of 2-in. [50 mm] screen/riser assemblies. The most common casing sizes are 2 to 3 in. [50 to 75 mm]. Large drive rods can be advanced with large vibratory drills (Guide [D6286](#)). Threaded sections can be outfitted with o-ring seals or polytetrafluoroethylene (PTFE) tape to reduce groundwater infiltration. Drive casings are equipped with expendable steel or aluminum drive points that are left in the bottom of the well. Depending on well design, the bottom of the casing may be advanced from a few inches [75 mm] to few feet deeper [1 m] than the bottom of the desired screen interval to separate the expendable point from the well if desired. Alternately, dual tube systems may use an inner rod equipped with an attached drive point that is removed before well insertion. An expendable cutting shoe is often used with these systems and the shoe is left in place as the casing is retracted to set the well.

7.2 *Well Screen and Riser Pipe*—Slotted PVC with flush-joint riser pipe is commonly used in the installation of direct push monitoring wells. Sizes range from ½ in. to 2 in. (Schedules 40 and 80) [15 to 50 mm]. Other riser screen and riser materials such as stainless steel, polyethylene, or PTFE may be used. PVC is preferred due to its low cost and because it is relatively inert. Selection of well material should consider possible material interactions with the contaminant being monitored. While PVC and stainless steel are commonly used in most monitoring wells without any problem, there are extreme environmental conditions that could lead to failure of

these materials. PVC should not be exposed to neat organic solvents (that is, pure products) that are PVC solvents or swelling agents or to extremely high concentrations of these chemicals (approaching a saturated solution) (5, 12-16). Although there is very little data on the expected life of steel well casings (17), stainless steel is reported to perform well in most environments (17-19). Stainless steel should be avoided in extremely corrosive conditions, which may include water high in chlorides, low in pH, high in dissolved solids or high in dissolved oxygen (20-23). As screen and riser pipe may contain chemical residue from manufacturing, the screen and riser should be cleaned prior to installation. Most manufacturers supply pre-cleaned riser pipe. Threaded joints of the riser pipe can be sealed with O-rings or by using PTFE tape.

7.2.1 Slotted (PVC) or wire-wrapped (steel) well screen is normally supplied with slot widths of 0.01 or 0.02 in. [0.25 to 0.50 mm]. The screen can be wrapped with stainless steel wire mesh of 0.006 in. [0.15 mm] opening. The selection of slot size depends on the formation grain size distribution and if a sand pack will be needed to reduce turbidity. Practice D5092 provides slot size and sand pack selection criteria.

7.2.2 A sediment trap may be specified. If the riser is lifted and needs to be pushed back into place, pointed sediment traps are useful.

7.3 Sand Pack—The use of sand packs assists in reducing turbidity and the amount of well development required to obtain low turbidity samples. Monitoring wells without sand packs will likely yield more turbid water, which may impact the results of some chemical analyses. However, a filter can be as thin as several grain diameters to be effective. Improving well yield is not the purpose of the sand pack; yield is controlled by the formation. For monitoring of metals, filtering of samples (Guide D6564) may be required for samples with elevated turbidity levels.

7.3.1 Sand Pack Selection and Size Range—Formations of clean sands and gravels (that is, less than 5 % fines) may not require a sand pack. For soil containing appreciable fines, use of a sand pack should be considered. The gradation requirement depends on the particle size distribution in the target aquifer. Refer to Practice D5092 for criteria on sand pack design.

7.3.2 Pre-packed Screens—Pre-packed screen systems are intended to ease the installation of sand in direct push cased monitoring wells by carrying it with the casing. The prepack sections use hollow stainless steel screen casings to accommodate the slotted riser. A screen opening of 0.006 in. [0.15 mm] is typical. Pre-packed screen systems addressed in Practice D6725 are used in two tube systems and allow for better control of placement of well screen filter pack and top seal and allow for placement of fine sand filters needed for fine grained formations (Practice D5092).

7.4 Seals—In addition to the sand pack, a seal above the screen is needed. Current local agency regulations and environmental guidance documents (7, 10, 24-26) require the installation of annular seals and grouting of the well annulus to prevent potential cross contamination along the well bore and the possibility of surface water or chemical spills from contaminating the monitored aquifer(s). Sealing is necessary to

prevent infiltration of surface runoff and to maintain the hydraulic integrity of confining layers. The sealing required depends on the formation, well type, and installation technique (Section 8). Several methods can be used to assure a seal above the screened zone. Most completion methods with cased systems use tremie grout placed as the casing is withdrawn. The grout can be bentonite or cement similar to that specified in Guides D6001, D6282, and Practice D5092. A typical well completion diagram is shown on Fig. 1. A grout barrier of fine to medium sand is used to protect the sand pack or screened interval from infiltration of grout, which can change the local water chemistry. Practice D5092 addresses this subject.

7.4.1 Mechanical techniques can also be used to create an effective seal. For example, Fig. 2 depicts a solid metal sleeve left in the ground, and Fig. 3 shows modular expandable foam and bentonite sleeves used above the screened interval. Rubber wiper seal may also be used. Whether this barrier is formed by the addition of fine to medium sand, by collapse of the surrounding formation, or mechanically, the materials employed must be chosen to be compatible with the local groundwater conditions and contaminants of interest.

7.5 Modular Well Systems—The most recent developments have been towards the use of modular components for placing sand pack and seals. Pre-packed screens can be used with most drive systems. The screens are stainless steel wire mesh filled with sand of different gradations. Fig. 1 and Fig. 3 show the use of these modular sand packs.

7.6 Other Variations—Numerous innovations have been developed for groundwater monitoring through direct push well systems. For example, multiple screened sections can be completed in one installation, using Continuous Multichannel Tubing (CMT) and sampling of multiple zones can be performed by using packers or sampling ports for groundwater extraction (28, 29). This system shown in Fig. 4 and is normally installed in rotary drilling operations, but can be

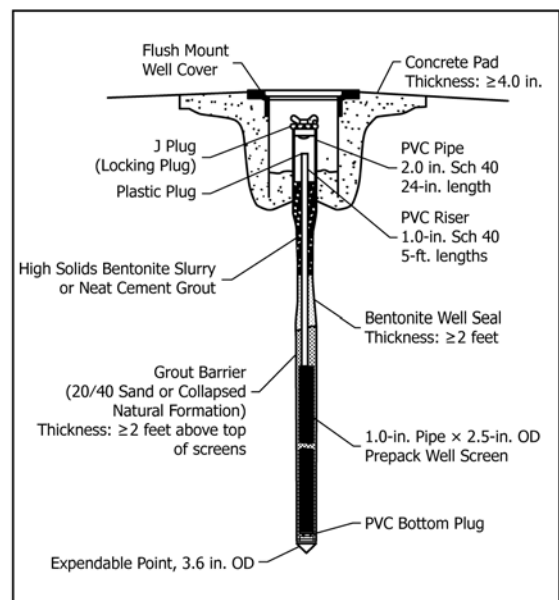

FIG. 1 Example of a Completed Direct Push Monitoring Well (27)

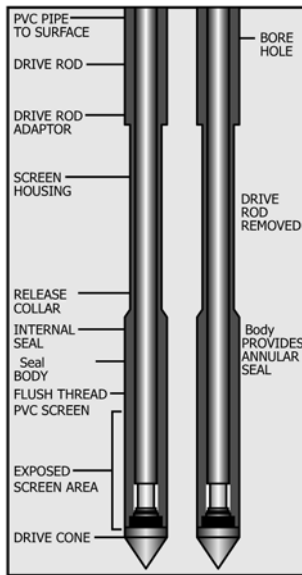

FIG. 2 Example of a Steel Seal Body Above the Screen

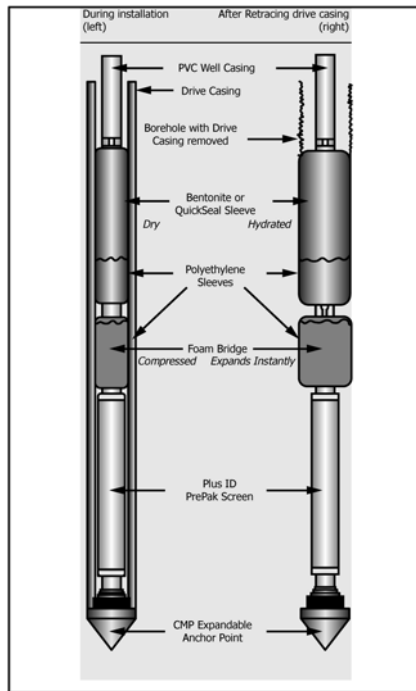

FIG. 3 Direct Push Well with Modular Sealing Components

installed in large diameter direct push casing tubes. The multichannel HDPE tube is equipped with prepack sand packs and bentonite sealing systems to isolate zones for testing. Another recent development has been the use of an everting flexible liner system to seal the borehole and isolate contaminated zones and water sampling intervals (30).

8. Installation Techniques

8.1 There are several techniques for installing direct push monitoring wells. Techniques can be broadly classified into two categories: exposed screen techniques, and protected screen techniques. Each of the systems described hereafter may

require a unique installation procedure. Regardless of the choice of techniques and systems, a written operating procedure should be developed which allows some flexibility in response to field conditions. Project sampling plans and standard operating procedures should be consulted prior to installation.

8.2 *Direct Push Driving Equipment*—Direct push Guides D6001 and D6282 describe typical driving systems. Some systems are manual (slam bar, hand held electric or pneumatic hammers), static weight (cone penetrometers), percussion (hydraulic hammers, air hammers, electric hammers), and vibratory systems. In some cases, direct push monitoring wells may be installed in combination with rotary drilling.

8.3 *Exposed Screen Techniques*—One method of installing direct push wells is to advance a screen and riser of constant diameter that remain in direct contact with the formation during installation. The riser may be driven either alone or by using a mandrel rod inside the screen and riser (Fig. 5). Because the well screen is exposed to soil during driving, development by surging or jetting will be necessary to remove sediment from the screen slots (see Guide D5521 for well development methods). When installing exposed screen monitoring wells the slotted screens may become clogged with fine-grained materials if any are present in the penetrated formation. If the zone penetrated with the slotted screens is contaminated the materials trapped in the screens may be contaminated and result in cross contamination of the screened interval. Additional development may be required to remove the material clogged in the screens. Failure to remove such material may bias sample quality.

8.3.1 *Driven or Jetted Wellpoints*—As is commonly practiced in other hydrology applications (for example, construction site dewatering), well points can be jetted or driven (hammer or vibration) through sands. Fig. 5 shows this simple type of installation. At many saturated sand sites, the well point can be quickly driven using vibrators or vibratory hammers. Well points are generally 2 to 3 in. [50 to 75 mm] diameter and constructed of slotted or wire-wrapped steel or stainless steel. Slot widths of 0.01 to 0.02 in. [0.25 to 0.50 mm] are typical. These monitoring wells perform well in clean, coarse to medium sand deposits, but they do not have a sand pack and will yield sediment in soils containing fines. The use of jetting will reduce effective sealing above the screen. Installation by jetting with water or other fluids is not recommended for environmental water quality monitoring wells, as injection of large volumes of fluids into the local formation will result in significant alteration of the local groundwater geochemistry.

8.3.2 *Mandrel-Driven Screen and Riser*—Fig. 6 shows a section of poly vinyl chloride (PVC) screen and riser that is driven using inner steel CPT rods. A drive tip slightly over-reams the hole to reduce friction on the riser pipes. Through experience, the drive tip diameter can be optimized to assure good sealing above the screen. With this type of installation, rigorous development to remove possible cross-contamination must be performed. A combination of mechanical surging and continuous withdrawal of the well water is effective for this purpose. This well installation method is often used on cone

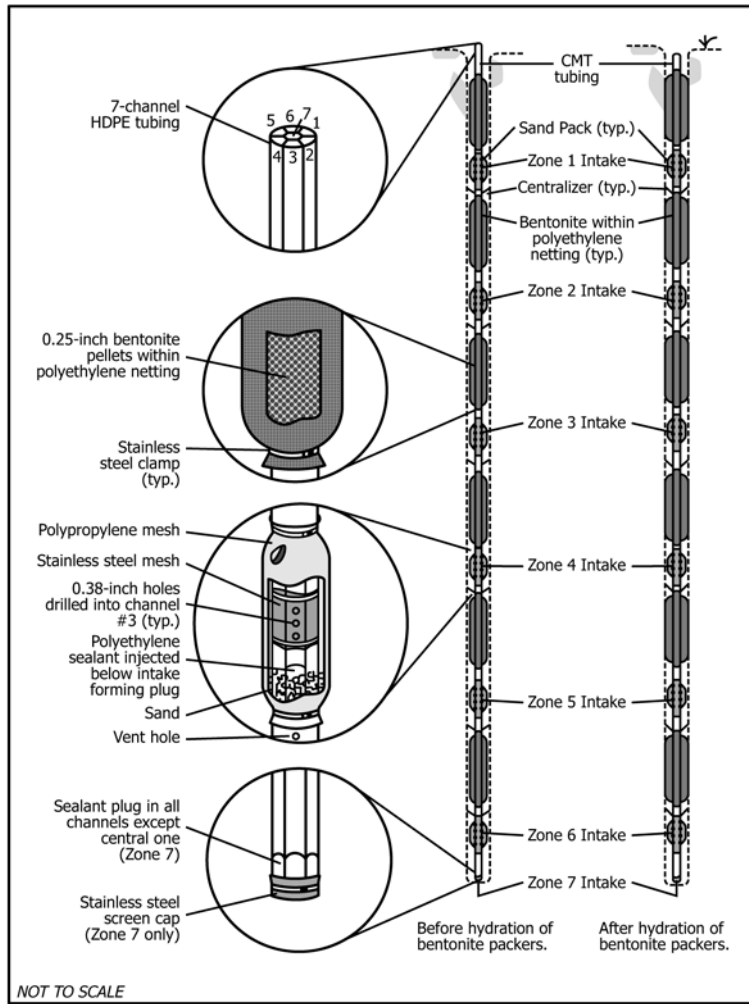

FIG. 4 Schematic of a CMT Well (Courtesy of Solinist) (28)

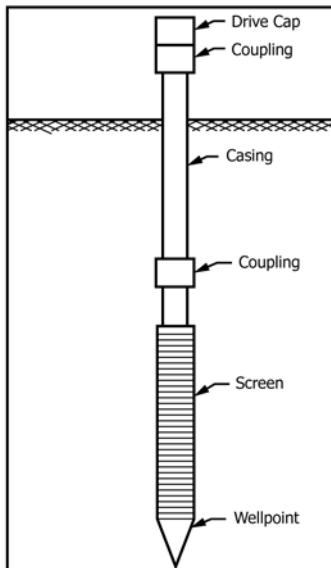

FIG. 5 Example of an Exposed-Screen Driven Well Point (17)

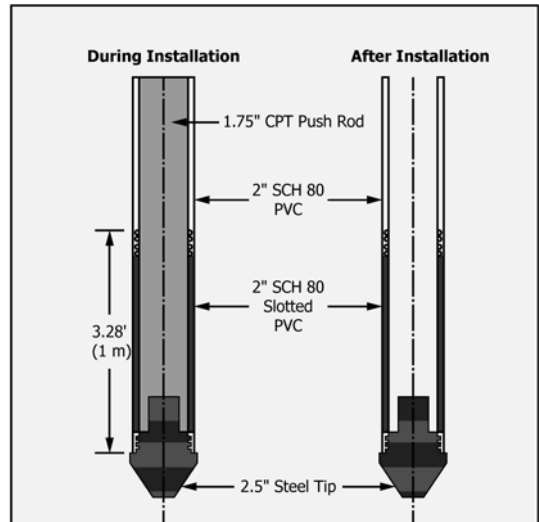

FIG. 6 Mandrel-Pushed Screen and Riser

penetrometer test systems using static push (Practice D6067). See Guide D5521 for well development guidance.

8.4 Protected Screen Techniques—Protected screen techniques do not allow the well screen to come in contact with the formation until the screened section is at the target installation

depth. The well is driven inside of a protective outer casing, or lowered down into the casing once it has been driven to the desired depth. A variety of sand pack and sealing approaches are available, as discussed in subsequent sections. There may be difficulty in installing sand pack or grout in the annular space that is created. However, the use of pre-packed well screens facilitates the quick and accurate placement of the sand pack. Additionally, new grouting technology allows for efficient and accurate placement of seals and grout by the bottom-up tremie method recommended by EPA guidance (17, 24, 25) and most local regulatory agencies.

8.4.1 *Single Rod Water Sampler Screens*—Guide D6001 describes rod-driven water samplers, which can be driven and left in place as temporary monitoring points without backfilling. Fig. 7 shows a typical rod-driven water sampler. If the drive rod is smaller in diameter than the sampler body, surface infiltration can be prevented by grouting the annular space above the sampler body. Otherwise, the only seal will be between the formation and that portion of sampler body above the screen. If the annulus between the drive rod and soil remains unsealed, such installations are satisfactory only for monitoring the uppermost portions of surficial aquifers, and where potential contamination by infiltration from above is not a concern. Most conventional direct push water samplers of this type are used as observation wells and are typically not left in the ground for long periods due to equipment expense.

8.4.2 *Single Casing Tube Method*—Often DP wells are installed by first advancing a single casing tube with expendable point to the base of the desired screen interval. This is a preferred method over the sampling mode below (8.4.3) because the target aquifer is identified and the problems associated with sampling disturbance can be better controlled such as in heaving sand conditions. The casing tube is typically the outer tube of the dual tube direct push system. Once the driven casing is in position the well may be built through the casing as it is retracted as with conventional rotary monitoring wells (D5092). Due to the small diameter of many DP systems gravity pouring or tremie installation of filter pack is difficult and time consuming. For this reason many DP wells are

constructed using prepacked well screens (D6725). After the casing with expendable point is advanced to depth the pre-packed screens and PVC riser are assembled and lowered down the open bore of the casing (Fig. 8). Once the PVC riser and prepacked screens are in place the drive casing is slowly retracted. As the drive casing is retracted above the prepacked screens either natural formation collapse or gravity poured sand is used to construct a grout barrier above the screen. Then the desired grout slurry is pumped in bottom-up using a tremie tube. Finally well protection is installed complying with local regulations and work plan requirements. Once completed (Fig. 1) the monitoring well meets the basic requirements for groundwater monitoring (8, 10, and 25).

8.4.3 *Dual Tube Systems—Sampling Mode*—With the dual tube system, inner rods and outer steel drive casings are advanced to the desired depth simultaneously. The dual tube system may be used to collect soil samples as the casing is advanced (D6282). If soil sampling is performed an expendable cutting shoe (Fig. 9 b.) may be required if prepacked well screens are to be installed. Alternately, the inner drive casing may be equipped with a solid drive point to close off the cutting shoe during advancement (Fig. 10). Once at the desired depth the inner rod with drive point (or sample) is tripped out. The well screen and riser are assembled and lowered down the open bore of the outer drive rod into position. Next the outer drive casing is slowly retracted to set the well screen in the formation. As the drive casing is retracted above the top of the screen either natural formation collapse or sand installed from the surface may be used to construct a grout barrier. Next the desired grout mixture is pumped in as the casing is retracted to the surface. Often a tremie tube is used to install the grout bottom-up to achieve a high integrity seal. Finally well protection is installed complying with local regulations and work plan requirements. Once completed (Fig. 1) the monitoring well meets the basic requirements for groundwater monitoring (8, 10, and 25).

8.4.4 *Filter Packs and Seals*—In a shallow well in a surficial aquifer it may be appropriate to allow the formation to collapse

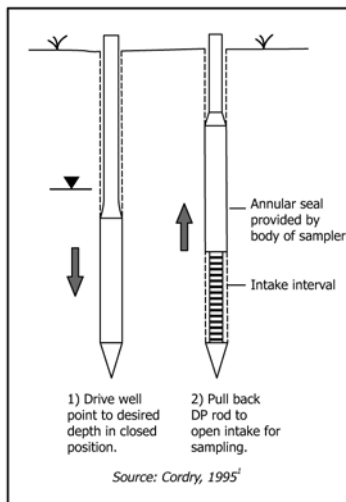

FIG. 7 Typical Rod Driven Water Sampler (31)

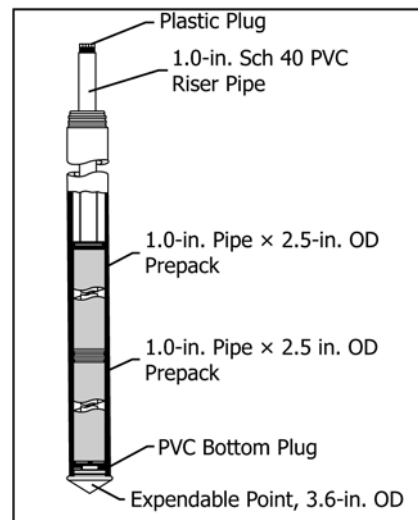

FIG. 8 Example of Prepacked Screens Installed After the Drive Casing is in Position ASTM Practice D6725 (27)

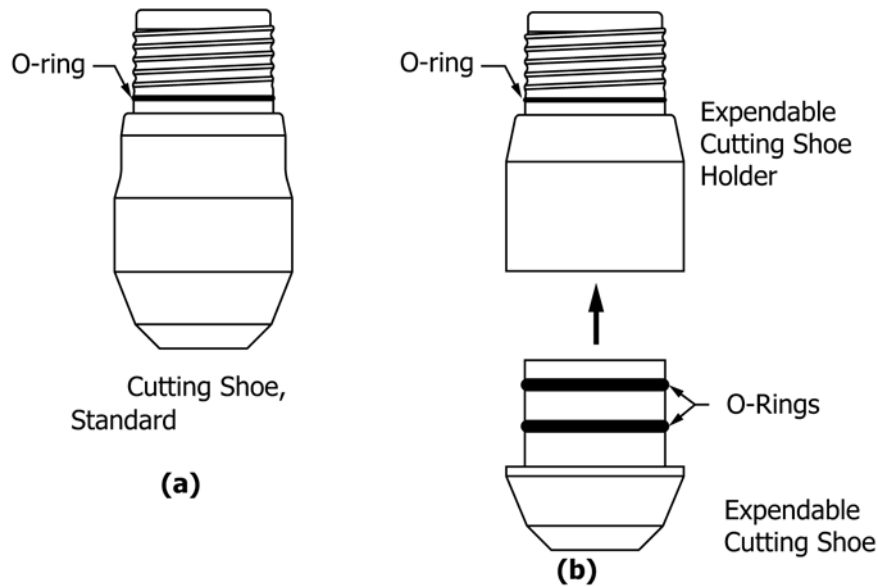

FIG. 9 (a) Standard Dual Tube Cutting Shoe and (b) Expendable Dual Tube Cutting Shoe for Use When Installing Well Screen

back in against the screen and riser without adding a sand pack as shown with temporary exposed screen single rod systems as long as the correct slot size is used for the screen. In this case the surface completion method must provide adequate protection against infiltration by surface runoff. Otherwise for dual tube systems, sand pack and seals, if not provided by Practice D6725 on pre-packed or modular construction (7.3.2 and 7.5, respectively), can be placed by tremie or pouring methods, or by pumping.

9. Installation Procedure

9.1 *Decontamination of Materials*—Well components and installation equipment may require decontamination before and/or after well installation. Consult Practice D5088 for decontamination procedures.

9.2 *Installation*—Drive the direct push monitoring well in accordance with the standard operating procedures developed for the push system and/or monitoring well (8.1). Record all assembly lengths and rod or casing lengths to the nearest 0.1 ft [0.03 m] or better, and any unusual driving conditions as the push progresses on the well completion log (Fig. 11). Record water levels if required (see Test Method D4750). For cased systems in sand below the water table, it may be necessary to fill the casing with clean water to prevent sand heaving. With cased systems, it may be necessary to check for groundwater infiltration using a water level meter prior to detaching the expendable tip. This check is imperative in conditions of contaminated perched water.

9.3 *Centralizers*—For small diameter casings (less than half the size of the borehole created), the use of centralizers prevents deflections of the riser during backfilling of the annular space. Riser deflection can later interfere with the free passage of bailers and other equipment through the casing. Centralizers may also assist in sealing procedures by keeping the riser in a consistent position within the borehole.

9.4 *Sealing*—Procedures for sealing direct push monitoring wells are similar to those in Practice D5092. Direct push sealing considerations and procedures are also addressed in sampling Guides D6001 and D6282. Groundwater that has entered the cased system may cause difficulty in placing seal materials by the gravity-pouring method. New grouting equipment allows for efficient and effective installation of well seals and grout (20 to 30 % solids bentonite) by bottom-up tremie methods with tremie tubes as small as 0.25-in. inside diameter. Depth to the top of seal materials can be periodically checked using rods or weighted tape lowered into the annular space.

9.5 *Surface Completion*—Well capping details vary from simple to detailed, similar to rotary drilled monitoring wells (Practice D5092). After the final height of the riser is established, record the elevation of the top of the riser pipe.

9.6 *Well Development*—Direct-push monitoring wells can be developed using mechanical surging, pumping and backwashing, hydraulic jetting, or inertial lift pumps. The first three methods are described in detail in Guide D5521. Inertial-lift pumps (also referred to as tubing check valve pumps) are operated by oscillating a piece of rigid or semi-rigid tubing, with a simple ball check valve on the down-hole end, in the water column within the well screen. The tubing and check valve act like a surge block, alternately forcing water to flow into the well (on the upstroke) and out of the well (on the downstroke), and significantly agitating the water column in the well and the water contained within the filter pack and the adjacent formation materials. The downstroke causes a back-washing action to loosen bridges in the formation and filter pack, and fills the tubing with water and suspended sediment brought into the well during the upstroke. The upstroke pulls dislodged fine-grained material into the well and causes water in the tubing to move upward under inertia, as the tubing is pushed back into the well. This oscillation of the tubing is repeated until water and suspended sediment are discharged

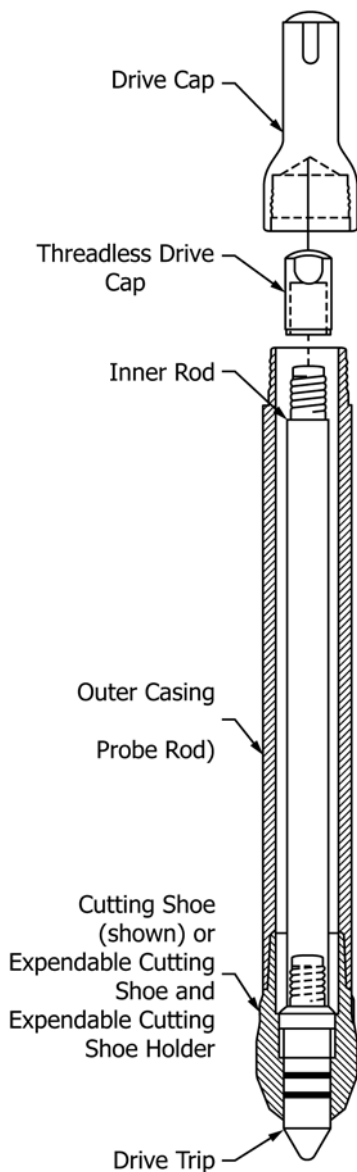

FIG. 10 A solid point may be used to plug the cutting shoe if sampling is not required during dual tube advancement.

from the tubing at the surface; development is complete when the water being discharged is free of suspended sediment. Additional purging with a pumping method that does not surge the well (peristaltic, bladder, etc.) may be needed to achieve low turbidity levels required for some analytes. Information on different monitoring well development and purging devices is available in Guide [D6634](#). Details on development methods may be found in Practice [D5092](#), Guide [D5521](#), and Refs. ([6](#), [7](#), [10](#), [24](#), [25](#)).

9.6.1 In predominantly fine-grained formation materials (with a high silt and clay content), attempts to develop direct-push wells may not improve well yield and may result in increases in suspended sediment, clogging of the well screen and filter pack, or damage to the screen or filter pack. Pumping the well at a low flow rate, to the point at which pump discharge is free of suspended sediment (using a peristaltic

pump, bladder pump, or gas-displacement pump), is often an effective development method for wells installed in fine-grained formations.

9.6.2 Well development should be done either after the well casing, screen and filter pack have been installed and the drive casing has been pulled back to just above the top of the screen (that is, prior to installation of annular seal materials), or after the entire well has been completed. In the latter case, it is necessary to wait until the annular seal materials have set or cured, typically 48 to 72 hours after well installation. Small inertial pumps are usually effective for development of the smaller diameter DP wells, especially in coarse grained formations. The simultaneous surging and purging action of an inertial pump usually helps to clear fines from the well, filter pack and nearby formation and establish flow into the well. Water quality parameters (Specific conductance, pH, DO, ORP, turbidity) may be monitored to verify adequate development.

9.7 *Purging and Sampling*—Purging a direct-push monitoring well is generally required prior to sampling the well. Several types of devices appropriate for use in purging and sampling a direct-push monitoring well, and the procedures for using them, are described in detail in Guide [D6634](#). Because of the smaller inside diameter of most direct-push well, the selection of devices is more limited than it is for wells 2 in. [50 mm] nominal diameter and larger. Bladder pumps, gas-displacement pumps, peristaltic pumps, bailers, and inertial-lift (tubing check valve) pumps may all be used for both purging and sampling. Guide [D6634](#) should be consulted to determine the conditions and analytes for which each device is appropriate. Additional information on sampling and equipment methods and procedures can be found in Guide [D4448](#), and Practices [D6771](#) and [D7929](#), and Refs. ([6](#), [7](#), [10](#), [24](#), [25](#)). Information on decontamination of sampling equipment is provided in Practice [D5088](#). In wells in which low-flow purging and sampling methods (Practice [D6771](#)) are to be used, or from which low-turbidity samples are required, bailers and inertial-lift pumps are not appropriate devices ([32](#)). Bladder pumps are now available in sizes as small as ½ in. diameter ([33](#)) and are well suited for low flow sampling. Low flow purging and sampling (Practice [D6771](#)) is highly recommended when sampling for metals in groundwater or other parameters that are affected by elevated turbidity, as well as sampling VOC's.

9.8 *Measuring Hydraulic Conductivity*—A pneumatic slug test system ([34](#)) has been developed so that slug tests of the smaller diameter DP wells ([35](#), [36](#)) may be performed to determine local formation hydraulic conductivity (Practice [D7242](#)). The smaller diameter DP wells also may be used effectively as observation wells during pumping tests.

9.9 *Maintenance*—Monitoring wells that will be used for sufficiently long that biofouling or silt accumulation will be a concern may require periodic maintenance. Maintenance practices might include disinfection, acid treatment, and redevelopment and purging. Refer to Practice [D5978](#) on well maintenance for more information. However, using acid on stainless steel systems is not recommended because of problems with



CPT WELL INSTALLATION REPORT

Project: _____		Observation Well: _____	
City/State: _____		CPT ID: _____	
Client: _____		Installation Date: _____	
Crew Chief: _____		Location: _____	
File No: _____			

Ground El. _____ El. Datum _____ Comments: _____		Type of Protective Cover/Lock _____ Depth of Top of Roadway Box below Ground Surface _____ ft Depth of Top of Riser Pipe below Ground Surface _____ ft Type of Protective Casing: _____ Length _____ ft Inside Diameter _____ in Depth of Bottom of Roadway Box _____ ft Seals: <table style="width: 100%; border-collapse: collapse;"> <thead> <tr> <th style="text-align: left;">Type</th> <th style="text-align: left;">Depth to Top (ft)</th> <th style="text-align: left;">Thickness (ft)</th> </tr> </thead> <tbody> <tr> <td> </td> <td> </td> <td> </td> </tr> </tbody> </table> Type of Riser Pipe: _____ Inside Diameter of Riser Pipe _____ in Type of Backfill around Riser _____ Diameter of Largest CPT Expander _____ in Depth of Top of Wellpoint _____ ft Type of Point or Manufacture: _____ Screen Gauge or Size of Openings _____ in Diameter of Wellpoint _____ in Depth of Bottom of Wellpoint _____ ft Silt Trap _____ Depth of Bottom of Borehole _____ ft (Depth refer to ground surface)	Type	Depth to Top (ft)	Thickness (ft)			
Type	Depth to Top (ft)	Thickness (ft)						

ft	ft	ft	ft
Riser length (L1)	Screen length (L2)	Length of silt trap (L3)	Total length
+ _____	+ _____	+ _____	= _____

FIG. 11 Example of a Direct Push Well Completion Report

corrosion, and both disinfection and acid treatment are discouraged for environmental water quality monitoring wells as these practices may significantly alter the local chemistry.

9.10 Abandonment/Decommissioning—Direct push sampling wells may require removal or closure either at the end of their service life or if an installation attempt is unsuccessful (for example, equipment breakage or failure to reach target depth). The closure and plugging of such wells should be done in accordance with Practice D5299, relative to techniques for direct push wells. It may be sufficient to fill the screen and riser with an impermeable grout, or if plugging the well is not acceptable, the casing may be removed by rotary over-drilling using a hollow stem auger.

10. Report: Test Data Sheet(s)/Form(s)

10.1 The methodology used to specify how data are recorded on the test data sheet(s)/form(s), as given below, is covered in 1.6.

10.2 Record as a minimum the following general information:

10.2.1 Record and report information as required in the sampling plan and as noted in Section 8 on the well installation. An example of a well completion report form is shown on Fig. 11.

10.2.2 Report any subsurface exploration data that are required in the sampling plan and consult Guide D5434 on logging of subsurface investigations. All records must be dated and include the names of those performing the work.

10.2.3 If the well data are to be used in a Geographic Information System, consult Guide D5254 on minimum data elements for documenting a groundwater sampling site.

10.2.4 Well development events may require a separate report of monitored groundwater conditions during development.

10.2.5 A field notebook should be kept to document all activities relevant to the work plan. Activities include sampling

events and conditions that occur during installation, development, and sampling as part of a quality assurance program.

10.2.6 If samples are obtained during the installation, as with two-tube soil sampling Guide [D6282](#), record and report the sample intervals and the data that are required.

10.2.7 If water samples are acquired during the push (Guide [D6001](#)), record the purge water volumes and any monitored water quality indicators.

10.2.8 Record and report the depth of the push, and details such as effective screen length, effective seal lengths, backfilling and sealing methods. As the well is completed, ensure that all necessary installation information is recorded.

10.3 Record as a minimum the following data:

10.3.1 Record all drilling depths, and installation depths and lengths, the nearest 0.1 ft. [0.03 m] or better on well completion diagrams used in [10.2](#).

10.3.2 Record all quantities and volumes for filter pack, grout, and backfill to three significant digits.

11. Keywords

11.1 direct push; groundwater; monitoring well; site investigation

REFERENCES

- (1) Foster, M., Stefanov, J., Bauder, T., Shinn, J., and Wilson, R., (1995), *Ground Water Monitoring Review*, National Ground Water Association, Dublin, OH.
- (2) Thornton, D., Ita, S., and Larsen, K., 1997, Broader Use of Innovative Ground Water Access Technologies. In Superfund XVIII Conference Proceedings, Vol 2. p. 639 - 646. E.J. Krause and Assoc. Washington, D.C.
- (3) McCall, W., Stover, S., Enos, C., and Fuhrmann, G., 1997, Field Comparison of Direct Push Prepacked Screen Monitoring Wells to Paired HSA 2" PVC Wells. In Superfund XVIII Conference Proceedings, Vol 2. p. 647 -655. E.J. Krause and Assoc. Washington, D.C.
- (4) McCall, W., 1999, "Field Comparison of Paired direct push and HSA Monitoring Wells," Natural Attenuation of Chlorinated Solvents, Petroleum Hydrocarbons, and Other Organic Compounds," April 19-22, 1999, Alleman and Leeson, eds., Battelle Press, Columbus, OH and Richland WA.
- (5) Kram, Mark, D. Lorenzana, J. Michaelsen, E. Lory, 2001. Performance Comparison: DirectPush Wells Versus Drilled Wells, Naval Facilities Engineering Service Center Technical Report, TR-2120-ENV, January 2001, 55 pp.
- (6) McCall, Wesley, David M. Nielsen, Stephen P. Farrington and Thomas M. Christy, Use of Direct Push Technologies in Environmental Site Characterization and Ground-Water Monitoring. *Practical Handbook of Environmental Site Characterization and Ground-Water Monitoring, 2nd Edition*. CRC Taylor & Fancis, Boca Raton, FL. Chapter 6, pages 345-472, 2006.
- (7) *Well Design and Construction for Monitoring Groundwater at Contaminated Sites*, (2014), California Environmental Protection Agency, Department of Toxic Substances Control, Sacramento, CA., www.dtsc.cs.gov/publications, June.
- (8) ITRC (Interstate Technology & Regulatory Council). 2006. *The Use of Direct-push Well Technology for Long-term Environmental Monitoring in Groundwater Investigations*. SCM-2. Washington, D.C.: Interstate Technology& Regulatory Council, Sampling, Characterization and Monitoring Team. www.itrcweb.org.
- (9) U.S. EPA, 1997. Expedited Site Assessment Tools for Underground Storage Tank Sites: A Guide for Regulators. Solid Waste and Emergency Response 5403G. EPA 510-B-97-001. March.
- (10) Ohio EPA, 2005. Chapter 15: Use of Direct Push Technologies for Soil and Ground Water Sampling. Ohio EPA, Division of Drinking and Ground Waters, Columbus, Ohio. www.epa.state.oh.us/ddagw. February.
- (11) Lackey, S.O., W. Myers, T.C. Christopherson, and J.J. Gottula, 2009. "In-Situ Study of Grout Materials 2001-2006 and 2007 Dye Tests," Nebraska Grout Task Force, Lincoln, NE: University of Nebraska, October 2009. <http://dhhs.ne.gov/publichealth/Documents/TheGroutStudy.pdf>
- (12) Parker, L.V. 1992. Suggested Guidelines for the Use of PTFE, PVC and Stainless Steel in Samplers and Well Casings. In *Current Practices in Ground Water and Vadose Zone Investigations*, ASTM STP 1118, David M. Nielsen and Martin N. Sara, editors, American Society for Testing and Materials, Philadelphia, pp. 217-229.
- (13) Parker, L.V. and T.A. Ranney. 1994. Softening of Rigid PVC by Aqueous Solutions of Organic Solvents. CRREL Special Report 94-27.
- (14) Parker, L.V. and T.A. Ranney. 1995. Additional Studies on the Softening of Rigid PVC by Aqueous Solutions of Organic Solvents. CRREL Special Report 95-8.
- (15) Parker, L.V. and T.A. Ranney. 1996. Further Studies on the Softening of Rigid PVC by Aqueous Solutions of Organic Solvents, CRREL Special Report 96-26.
- (16) Ranney, T.A. and L.V. Parker. 1997. Comparison of Fiberglass and Other Polymeric Well Casings: Part I. Susceptibility to Degradation by Chemicals. *Ground Water Monitoring and Remediation*, vol. 16, no.2: 97-103.
- (17) Aller, L., T.W. Bennett, G. Hackett, R.J. Petty, J.H. Lehr, H. Sedoris, D.M. Nielsen, and J.E. Denne. 1989. *Handbook of Suggested Practices for the Design and Installation of Groundwater Monitoring Wells*, National Water Well Association, Dublin, OH.
- (18) D. Driscoll, Fletcher G. 1986. *Groundwater and Wells*, Second Edition. Johnson Screens, St. Paul, MN.
- (19) Barcelona, M.J., J.P. Gibb, R.A. Miller. 1984. A Guide to the Selection of Materials for Monitoring Well Construction and Ground-Water Sampling. US Environmental Protection Agency Report Number EPA-600/2-84-024, Robert S. Kerr Environmental Research Laboratory, US EPA, Ada, OK.
- (20) Parker, L.V., A.D. Hewitt, and T.F. Jenkins. 1990. "Influence of Casing Materials on TraceLevel Chemicals in Well Water," *Ground Water Monitoring and Remediation* 10(2): 146-156.
- (21) Hewitt, A.D. 1992, "Potential of Common Well Casing Materials to Influence Aqueous Metal Concentrations," *Ground Water Monitoring and Remediation* 12(2): 131-136.
- (22) Hewitt, A.D. 1994 "Dynamic Study of Common Well Screen Materials," *Ground Water Monitoring and Remediation* 14(1): 87-94.
- (23) Oakley, D. and N.E. Korte. 1996. Nickel and Chromium in Ground Water Samples as Influenced by Well Construction and Sampling Methods, *Ground Water Monitoring and Remediation* 16(1): 93-99.
- (24) EPA 1986, Technical Enforcement Guidance Document (TEGD). OSWER Directive 9950.1, PB87-107751. September.

- (25) EPA 1992, RCRA Ground-Water Monitoring: Draft Technical Guidance. Office of Solid Waste. EPA/530-R-93-001, PB93-139 350. November.
- (26) Applied Research Associates, (1998), "Work Plan for direct push Monitoring Point Assessment," Contract No. F08037-98-C6002 task 32.03S, Air Force Research Laboratory, Air Base and Environmental Technology Division, Tyndall Air Force Base, August 31
- (27) Geoprobe Systems, (1999), "Geoprobe Prepack Screen Monitoring Well—Standard Operating Procedure," Technical Bulletins 99-2000 and - 2500, Geoprobe Systems, Salina, Kansas.
- (28) Einarson, M. D. and Cherry, J. A. (2002), A New Multilevel Ground Water Monitoring System Using Multichannel Tubing. *Groundwater Monitoring & Remediation*, 22: 52–65. doi: 10.1111/j.1745-6592.2002.tb00771.x
- (29) Dumble, P., Fuller, M., Beck, P., and P. Sojka, (2006), "Assessing contaminant migration pathways and vertical gradients in a low-permeability aquifer using multilevel borehole systems, *Land Contamination & Reclamation*, 14 (3), EPP Publications Ltd DOI 10.2462/09670513.698
- (30) Keller, C., (1999), "Brief Summary of the FLUTe Water Sampling Systems and Installation Procedures," Flexible Liner Underground Technologies LTD, 6 Easy St., Santa Fe, NM.
- (31) Cordry, K.E., 1995. "The Powerpunch," In *Proceedings of the 9th National Outdoor Action Conference*, National Ground Water Association, Columbus, OH.
- (32) Puls, Robert W., and Michael J. Barcelona, 1996. EPA Ground Water Issue: Low-Flow (Minimal Drawdown) Ground-Water Sampling Procedures. EPA/540/S-95/504. April.
- (33) Geoprobe, 2003. Geoprobe Model MB470 Mechanical Bladder Pump, Standard Operating Procedure. Technical Bulletin No. MK3013. Kejr Inc., Salina, KS. Revised January, 2011. www.geoprobe.com
- (34) Geoprobe, 2014. Geoprobe Pneumatic Slug Test Kit(GW1600) Installation and Operation Instruction for USB System. Instructional Bulletin No. MK3195. Kejr Inc., Salina, KS. January. www.geoprobe.com
- (35) Parker, Louise, Wesley McCall, Nathan Mulherin, Dale Williams and Susan Bigl, 2010. Comparison of Hydraulic Conductivity in Direct-Push Monitoring Wells, ERDC/CRREL TR-10-Draft. U.S. Army Corps of Engineers, Cold Regions Research and Engineering Laboratory, Hanover, NH. December.
- (36) Bartlett, Stephen A., Gary A. Robbins, J. Douglas Mandrick, Michael Barcelona, Wes McCall and Mark Kram, 2004. Comparison of Hydraulic Conductivity Determinations in Direct Push and Conventional Wells, Technical Report TR-2252-ENV. Naval Facilities Engineering Command, Engineering Service Center, Port Hueneme, CA. October.

SUMMARY OF CHANGES

In accordance with Committee D18 policy, this section identifies the location of changes to this standard since the last edition (2004 (Reapproved 2010)) that may impact the use of this standard. (July 1, 2016)

- (1) Units were converted to English [SI] rationalized units added significant digits requirements.
- (2) D18 requirements for significant digits and rounding and report section were added.
- (3) D3740 caveat was added.
- (4) New references were added from national, interstate, and state guidance documents.
- (5) Added new information on bladder pumps and purging and sampling methods.
- (6) Referred to subsequent Practice D6725 on direct push pre-packed screen wells and use in dual tube systems used in Practice D6282.
- (7) Added new references to Practice D7242 for slug testing small wells.
- (8) Removed the acceptability of shallow exposed screen temporary wells for long term monitoring.
- (9) Removed requirement for rinseate sample for every well.
- (10) Added information in Section 7 on CMT multipoint wells.
- (11) Expanded the dual tube section to include a single tube method and a sampling method and added two figures (Fig. 8 and 9) on expendable tips and closed point driving.

ASTM International takes no position respecting the validity of any patent rights asserted in connection with any item mentioned in this standard. Users of this standard are expressly advised that determination of the validity of any such patent rights, and the risk of infringement of such rights, are entirely their own responsibility.

This standard is subject to revision at any time by the responsible technical committee and must be reviewed every five years and if not revised, either reapproved or withdrawn. Your comments are invited either for revision of this standard or for additional standards and should be addressed to ASTM International Headquarters. Your comments will receive careful consideration at a meeting of the responsible technical committee, which you may attend. If you feel that your comments have not received a fair hearing you should make your views known to the ASTM Committee on Standards, at the address shown below.

This standard is copyrighted by ASTM International, 100 Barr Harbor Drive, PO Box C700, West Conshohocken, PA 19428-2959, United States. Individual reprints (single or multiple copies) of this standard may be obtained by contacting ASTM at the above address or at 610-832-9585 (phone), 610-832-9555 (fax), or service@astm.org (e-mail); or through the ASTM website (www.astm.org). Permission rights to photocopy the standard may also be secured from the Copyright Clearance Center, 222 Rosewood Drive, Danvers, MA 01923, Tel: (978) 646-2600; http://www.copyright.com/