



Designation: D6681 – 17

# Standard Test Method for Evaluation of Engine Oils in a High Speed, Single-Cylinder Diesel Engine—Caterpillar 1P Test Procedure<sup>1</sup>

This standard is issued under the fixed designation D6681; the number immediately following the designation indicates the year of original adoption or, in the case of revision, the year of last revision. A number in parentheses indicates the year of last reapproval. A superscript epsilon ( $\epsilon$ ) indicates an editorial change since the last revision or reapproval.

## INTRODUCTION

Any properly equipped laboratory without outside assistance can use the test method described in this standard. However, the ASTM Test Monitoring Center (TMC)<sup>2</sup> provides calibration oils and an assessment of the test results obtained on those oils by the laboratory. By this means the laboratory will know whether their use of the test method gives results statistically similar to those obtained by other laboratories. Furthermore, various agencies require that a laboratory utilize the TMC services in seeking qualification of oils against specifications. For example, the U.S. Army has such a requirement in some of its engine oil specifications. Accordingly, this test method is written for those laboratories that use the TMC services. Laboratories that choose not to use these services should ignore those portions of the test method that refer to the TMC. Information Letters issued periodically by the TMC may modify this method.<sup>3</sup> In addition, the TMC may issue supplementary memoranda related to the test method.

## 1. Scope\*

1.1 This test method covers and is required to evaluate the performance of engine oils intended to satisfy certain American Petroleum Institute (API) C service categories (included in Specification D4485). It is performed in a laboratory using a standardized high-speed, single-cylinder diesel engine.<sup>4</sup> Piston and ring groove deposit-forming tendency and oil consumption is measured. The piston, the rings, and the liner are also examined for distress and the rings for mobility.

1.2 The values stated in SI units are to be regarded as standard. No other units of measurement are included in this standard.

1.2.1 *Exceptions*—Where there is no direct SI equivalent such as screw threads, National Pipe Threads/diameters, tubing size, or where there is a sole source supply equipment specification.

<sup>1</sup> This test method is under the jurisdiction of ASTM Committee D02 on Petroleum Products, Liquid Fuels, and Lubricants and is the direct responsibility of Subcommittee D02.B0.02 on Heavy Duty Engine Oils.

Current edition approved May 1, 2017. Published May 2017. Originally approved in 2001. Last previous edition approved in 2016 as D6681 – 16. DOI: 10.1520/D6681-17.

<sup>2</sup> ASTM Test Monitoring Center (TMC), 6555 Penn Ave., Pittsburgh, PA 15206-4489.

<sup>3</sup> This edition incorporates revisions contained in all information letters through 16-1. Users of this test method shall contact the ASTM Test Monitoring Center to obtain the most recent information letters.

<sup>4</sup> Available from Caterpillar Inc., Engine System Technology Development, P.O. Box 610, Mossville, IL 61552-0610.

1.3 *This standard does not purport to address all of the safety concerns, if any, associated with its use. It is the responsibility of the user of this standard to establish appropriate safety and health practices and determine the applicability of regulatory limitations prior to use.* Being an engine test method, this standard does have definite hazards that require safe practices (see Appendix X2 on Safety).

1.4 The following is the Table of Contents:

	Section
Scope	1
Referenced Documents	2
Terminology	3
Summary of Test Method	4
Significance and Use	5
Apparatus and Installation	6
Intake Air System	6.2.1
Exhaust System	6.2.2
Fuel System	6.2.3
Oil Consumption System	6.2.4
Engine Oil System	6.2.5
Oil Heating System	6.2.5.1
Oil Sample Valve	6.2.5.2
Engine Coolant System	6.2.6
Engine Instrumentation	6.2.7
Reagents and Materials	7
Oil Samples	8
Preparation of Apparatus	9
General Engine Assembly Practices	9.1
Complete Engine Inspection	9.2
Copper Components	9.3
Engine Lubricant System Flush	9.4
Engine Piston Cooling Jets	9.5
Engine Measurements and Inspections	9.6
Cylinder Head	9.7
Valve Guide Bushings	9.8

\*A Summary of Changes section appears at the end of this standard

	Section	
Fuel Injector	9.9	
Piston and Rings	9.10	
Cylinder Liner	9.11	
Compression Ratio	9.12	
Engine Timing	9.13	
Engine Coolant System Cleaning Procedure	9.14	
Calibration and Standardization	10	
Test Cell Instrumentation	10.1	
Instrumentation Standards	10.2	
Coolant Flow	10.3	
Re-calibration Requirements	10.4	
Fuel Injectors	10.5	
Air Flow	10.6	
Intake Air Barrel	10.7	
Fuel Filter	10.8	
Oil Scale Flow Rates	10.9	
Calibration of Test Stands	10.10	
Extending Test Stand Calibration Period	10.11	
Test Run Numbering	10.13	
Humidity Calibration Requirements	10.14	
Calibration of Piston Deposit Raters	10.15	
Procedure	11	
Engine Break-in Procedure	11.1	
Cool-down Procedure	11.2	
Warm-up Procedure	11.3	
Shutdowns and Lost Time	11.4	
Periodic Measurements	11.5	
Engine Control Systems	11.6	
Engine Coolant	11.6.1	
Engine Fuel System	11.6.2	
Engine Oil Temperature	11.6.3	
Exhaust Pressure	11.6.4	
Intake Air	11.6.5	
Post-Test Procedures	11.7	
Piston Ring Side Clearances	11.7.1	
Piston Ratings	11.7.2	
Referee Ratings	11.7.3	
Ring End Gap Increase	11.7.4	
Cylinder Liner Wear	11.7.5	
Cylinder Liner Bore Polish	11.7.6	
Photographs	11.7.7	
Calculation and Interpretation of Results	12	
Test Validity	12.1	
Calculations	12.2	
Quality Index	12.2.1	
Oil Consumption	12.2.2	
Report	13	
Forms and Data Dictionary	13.1	
Test Validity	13.2	
Report Specifics	13.3	
Precision and Bias	14	
Precision	14.1	
Bias	14.1.4	
Keywords	15	
	Annexes	
Engine and Parts Warranty	Annex A1	
Instrument Locations, Measurements, and Calculations	Annex A2	
Cooling System Arrangement	Annex A3	
Intake Air Mass Flow Sensor Installation	Annex A4	
Fuel System Design and Required Components	Annex A5	
Oil System	Annex A6	
Exhaust and Intake Barrel Piping	Annex A7	
Humidity Probe Installation (Location)	Annex A8	
Return Goods Authorization (Claim Form)	Annex A9	
Engine Assembly Information	Annex A10	
Flushing Instructions and Apparatus	Annex A11	
Warm-up, Cool-down and Testing Conditions	Annex A12	
Piston and Liner Rating Modifications	Annex A13	
Additional Report Forms	Annex A14	
Test Report Forms	Annex A15	
	Appendixes	
Various Examples for Reference Purposes	Appendix X1	
Safety	Appendix X2	

*Development of International Standards, Guides and Recommendations issued by the World Trade Organization Technical Barriers to Trade (TBT) Committee.*

## 2. Referenced Documents

### 2.1 ASTM Standards:<sup>5</sup>

- [D86 Test Method for Distillation of Petroleum Products and Liquid Fuels at Atmospheric Pressure](#)
- [D93 Test Methods for Flash Point by Pensky-Martens Closed Cup Tester](#)
- [D97 Test Method for Pour Point of Petroleum Products](#)
- [D130 Test Method for Corrosiveness to Copper from Petroleum Products by Copper Strip Test](#)
- [D235 Specification for Mineral Spirits \(Petroleum Spirits\) \(Hydrocarbon Dry Cleaning Solvent\)](#)
- [D445 Test Method for Kinematic Viscosity of Transparent and Opaque Liquids \(and Calculation of Dynamic Viscosity\)](#)
- [D482 Test Method for Ash from Petroleum Products](#)
- [D524 Test Method for Ramsbottom Carbon Residue of Petroleum Products](#)
- [D613 Test Method for Cetane Number of Diesel Fuel Oil](#)
- [D664 Test Method for Acid Number of Petroleum Products by Potentiometric Titration](#)
- [D1319 Test Method for Hydrocarbon Types in Liquid Petroleum Products by Fluorescent Indicator Adsorption](#)
- [D2274 Test Method for Oxidation Stability of Distillate Fuel Oil \(Accelerated Method\)](#)
- [D2425 Test Method for Hydrocarbon Types in Middle Distillates by Mass Spectrometry](#)
- [D2500 Test Method for Cloud Point of Petroleum Products and Liquid Fuels](#)
- [D2622 Test Method for Sulfur in Petroleum Products by Wavelength Dispersive X-ray Fluorescence Spectrometry](#)
- [D2709 Test Method for Water and Sediment in Middle Distillate Fuels by Centrifuge](#)
- [D3227 Test Method for \(Thiol Mercaptan\) Sulfur in Gasoline, Kerosine, Aviation Turbine, and Distillate Fuels \(Potentiometric Method\)](#)
- [D3524 Test Method for Diesel Fuel Diluent in Used Diesel Engine Oils by Gas Chromatography](#)
- [D4175 Terminology Relating to Petroleum Products, Liquid Fuels, and Lubricants](#)
- [D4052 Test Method for Density, Relative Density, and API Gravity of Liquids by Digital Density Meter](#)
- [D4485 Specification for Performance of Active API Service Category Engine Oils](#)
- [D4739 Test Method for Base Number Determination by Potentiometric Hydrochloric Acid Titration](#)
- [D5185 Test Method for Multielement Determination of Used and Unused Lubricating Oils and Base Oils by Inductively Coupled Plasma Atomic Emission Spectrometry \(ICP-AES\)](#)

<sup>5</sup> For referenced ASTM standards, visit the ASTM website, [www.astm.org](http://www.astm.org), or contact ASTM Customer Service at [service@astm.org](mailto:service@astm.org). For *Annual Book of ASTM Standards* volume information, refer to the standard's Document Summary page on the ASTM website.

1.5 *This international standard was developed in accordance with internationally recognized principles on standardization established in the Decision on Principles for the*

**D5862** Test Method for Evaluation of Engine Oils in Two-Stroke Cycle Turbo-Supercharged 6V92TA Diesel Engine (Withdrawn 2009)<sup>6</sup>

**D6202** Test Method for Automotive Engine Oils on the Fuel Economy of Passenger Cars and Light-Duty Trucks in the Sequence VIA Spark Ignition Engine (Withdrawn 2009)<sup>6</sup>

**D6593** Test Method for Evaluation of Automotive Engine Oils for Inhibition of Deposit Formation in a Spark-Ignition Internal Combustion Engine Fueled with Gasoline and Operated Under Low-Temperature, Light-Duty Conditions

**D7422** Test Method for Evaluation of Diesel Engine Oils in T-12 Exhaust Gas Recirculation Diesel Engine

**E29** Practice for Using Significant Digits in Test Data to Determine Conformance with Specifications

**G40** Terminology Relating to Wear and Erosion

2.2 *SAE Standard:*

**SAE J183** Engine Oil Performance and Engine Service Classification<sup>7</sup>

2.3 *API Standard:*

**API 1509** Engine Service Classification and Guide to Crankcase Oil Selection<sup>8</sup>

2.4 *Other ASTM Document:*

**ASTM Deposit Rating Manual 20** (formerly CRC Manual 20)<sup>9</sup>

### 3. Terminology

3.1 *Definitions:*

3.1.1 *additive, n*—a material added to another, usually in a small amount, to impart or enhance desirable properties or to suppress undesirable properties. **D4175**

3.1.2 *automotive, adj*—descriptive of equipment associated with self-propelled machinery, usually vehicles driven by internal combustion engines. **D4485**

3.1.3 *blind reference oil, n*—a reference oil, the identity of which is unknown by the test facility. **D4175**

3.1.3.1 *Discussion*—This is a coded reference oil which is submitted by a source independent from the test facility.

3.1.4 *blowby, n—in internal combustion engines*, that portion of the the combustion products and unburned air/fuel mixture that leaks past piston rings into the engine crankcase during operation. **D4175**

3.1.5 *calibrate, v*—to determine the indication or output of a device (e.g., thermometer, manometer, engine) with respect to that of a standard.

3.1.6 *calibrated test stand, n*—a test stand on which the testing of reference material(s), conducted as specified in the standard, provided acceptable test results. **Sub. B Glossary**<sup>2</sup>

<sup>6</sup> The last approved version of this historical standard is referenced on [www.astm.org](http://www.astm.org).

<sup>7</sup> Available from SAE International (SAE), 400 Commonwealth Dr., Warrendale, PA 15096, <http://www.sae.org>.

<sup>8</sup> Available from American Petroleum Institute (API), 1220 L. St., NW, Washington, DC 20005-4070, <http://www.api.org>.

<sup>9</sup> For Stock #TMCML20, visit the ASTM website, [www.astm.org](http://www.astm.org), or contact ASTM International Customer Service at [service@astm.org](mailto:service@astm.org).

3.1.6.1 *Discussion*—In several automotive lubricant standard test methods, the ASTM Test Monitoring Center provides testing guidance and determines acceptability.

3.1.7 *candidate oil, n*—an oil which is intended to have the performance characteristics necessary to satisfy a specification and is to be tested against that specification. **D4175**

3.1.7.1 *Discussion*—These oils are mainly submitted for testing as *candidates* to satisfy a specified performance; hence the designation of the term.

3.1.8 *debris, n—in internal combustion engines*, solid contaminant materials unintentionally introduced into the engine or resulting from wear. **D5862**

3.1.9 *dispersant, n—in engine oil*, an additive that reduces deposits on oil-wetted engine surfaces primarily through suspension of particles. **D4175**

3.1.10 *engine oil, n*—a liquid that reduces friction or wear, or both, between the moving parts within an engine; removes heat, particularly from the underside of pistons; and serves as a combustion gas sealant for the piston rings. **D5862**

3.1.10.1 *Discussion*—It may contain additives to enhance certain properties. Inhibition of engine rusting, deposit formation, valve train wear, oil oxidation and, foaming are examples.

3.1.11 *heavy-duty, adj—in internal combustion engine operation*, characterized by average speeds, power output, and internal temperatures that are generally close to the potential maximums. **D4485**

3.1.12 *lubricant, n*—any material interposed between two surfaces that reduces the friction or wear, or both, between them. **D5862**

3.1.13 *lubricating oil, n*—a liquid lubricant, usually comprising several ingredients, including a major portion of base oil and minor portions of various additives. **D4175**<sup>2</sup>

3.1.14 *oxidation, n—of engine oil*, the reaction of the oil with an electron acceptor, generally oxygen, that can produce deleterious acidic or resinous materials often manifested as sludge formation, varnish formation, viscosity increase, or corrosion, or a combination thereof. **D4175**

3.1.15 *non-reference oil, n*—any oil other than a reference oil; such as a research formulation, commercial oil, or candidate oil. **D4175**

3.1.16 *purchaser, n—of an ASTM test*, person or organization that pays for the conduct of an ASTM test method on a specified product. **D6202**

3.1.17 *reference oil, n*—an oil of known performance characteristics, used as a basis for comparison.

3.1.17.1 *Discussion*—Reference oils are used to calibrate testing facilities, to compare the performance of other oils, or to evaluate other material (such as seals) that interact with oils. **D4175**

3.1.18 *scoring, n—in tribology*, a severe form of wear characterized by the formation of extensive grooves and scratches in the direction of sliding. **G40**

3.1.19 *scuffing, n—in lubrication*, damage caused by instantaneous localized welding between surfaces in relative motion which does not result in immobilization of the parts. **D6593**

3.1.20 *sponsor, n*—of an ASTM test method, an organization that is responsible for ensuring supply of the apparatus used in the test procedure portion of the test method. **D4175**

3.1.20.1 *Discussion*—In some instances, such as a test method for chemical analysis, an ASTM working group can be the sponsor of the test method. In other instances, a company with a self-interest may or may not be the developer of the test procedure used within the method, but is the sponsor of the test method.

3.1.21 *used oil, n*—any oil that has been in a piece of equipment (for example, an engine, gearbox, transformer, or turbine), whether operated or not. **D4175**

3.1.22 *varnish, n*—in internal combustion engines, a hard, dry, generally lustrous deposit that can be removed by solvents but not by wiping with a cloth. **D4175**

3.1.23 *wear, n*—the loss of material from a surface, generally occurring between two surfaces in relative motion, and resulting from mechanical or chemical action or a combination of both. **D7422**

## 4. Summary of Test Method

4.1 Prior to each test, the power section of the engine is disassembled, solvent-cleaned, measured, and rebuilt in strict accordance with the specifications. A new piston, ring assembly, and cylinder liner are measured and installed for each test. The engine crankcase is solvent-cleaned and worn or defective parts are replaced. The test stand is equipped with feedback control systems for fuel rate, engine speed, and other engine operating conditions. A suitable system for filtering, compressing, humidifying, and heating the inlet air is required along with a system for controlling the engine exhaust pressure. Test operations involve the control of the single-cylinder diesel test engine for a total of 360 h at specified speeds and fuel rate input using the test oil as a lubricant. A defined break-in precedes each test and is also used when restarting an engine. At the end of the test, the piston deposits are rated, the piston, rings and liners are photographed, inspected and measured, oil consumption is calculated and the oil is analyzed to determine the test results. Critical engine conditions are statistically analyzed to determine if the test was precisely operated. Test acceptability parameters for each calibration test are also statistically analyzed to determine if the engine/test stand produce the specified results.

## 5. Significance and Use

5.1 This is an accelerated engine oil test, performed in a standardized, calibrated, stationary single-cylinder diesel engine that gives a measure of (1) piston and ring groove deposit forming tendency, (2) piston, ring and liner scuffing and (3) oil consumption. The test is used in the establishment of diesel engine oil specification requirements as cited in Specification **D4485** for appropriate API Performance Category C oils (API 1509). The test method can also be used in diesel engine oil development.

## 6. Apparatus and Installation

6.1 The test engine is an electronically controlled, direct injection, in-head camshaft, single-cylinder diesel engine with

a four-valve arrangement. The engine has a 137.2 mm bore and a 165.1 mm stroke resulting in a displacement of 2.4 L.

6.1.1 The electronic control module (ECM) defines the desired engine fuel timing, monitors and limits maximum engine speed, maximum engine power, minimum oil pressure, and, optionally, maximum engine crankcase pressure. The ECM also controls the fuel injection duration that defines the engine fuel rate based on set conditions from the test cell feedback control systems. The oil pressure is also set by the ECM with signals to the 1Y3867 engine air pressure controller (Mamac) to modulate the facility air supply to the 1Y3898 Johnson Controls relief valve.

6.1.2 The 1Y3700 engine arrangement also consists of inlet air piping and hoses from the cylinder head to the air barrel and exhaust piping and bellows from the cylinder head to the exhaust barrel that are specifically designed for oil testing. See the Caterpillar Service Manual.<sup>4</sup>

6.2 Equip the engine test stand with the following accessories or equipment:

6.2.1 *Intake Air System*—The intake air system components from the cylinder head to the air barrel are a part of the basic 1Y3700 engine arrangement. These components consisting of an adapter, elbow, hose, clamps, and flanged tube can be found in the 1Y3700 Parts Book.<sup>4</sup>

6.2.1.1 Purchase the 1Y3978 intake air barrel (which is almost identical to the exhaust barrel except for the top cover) that has been specifically designed from one of the three approved manufacturers.<sup>10,11</sup> Install the intake air barrel at the location shown in **Annex A7**. Do not add insulation to the barrel.

6.2.1.2 Paint the inside of the intake air piping with Caterpillar yellow primer or red Glyptal prior to installation.<sup>12,11</sup>

6.2.1.3 Install the air heater elements in the intake air barrel as specified in **Annex A7** (even if they will not be supplied with electricity).<sup>13,11</sup>

6.2.1.4 Use an air filter capable of filtering particles 10 μ (or smaller).

6.2.1.5 Use a Sierra Model 780 airflow meter with Feature 1 = F6, Feature 2 = CG and calibration temperature = 60 °C to measure intake airflow for each calibration test.<sup>14,11</sup> **Annex A4** shows the piping requirements for the installation of the Sierra Model 780 airflow meter.

6.2.1.6 Measure the inlet air temperature at the location shown in **Annex A2**. Measure the inlet air pressure at the air

<sup>10</sup> The sole sources of supply of the intake air barrel known to the committee at this time are Cimino Machinery Corp., 5958 South Central Ave., Chicago, IL 60638; Gaspar Inc., 4106 Mahoning Rd. N.E., Canton, OH 44705; and M.L. Wyrick Welding, 2301 Zanderson Highway 16 N, Jourdanton, TX 78026.

<sup>11</sup> If you are aware of alternative suppliers, please provide this information to ASTM International Headquarters. Your comments will receive careful consideration at a meeting of the responsible technical committee<sup>1</sup>, which you may attend.

<sup>12</sup> The sole source of supply of the crankcase paint primer known to the committee at this time is BASF Coating and Colorant Div., P.O. Box 1297, Morganton, NC 28655. (Primer No.A123590 and BASF Part No.U27YD005, Yellow CAT Primer Part No.IE2083A.)

<sup>13</sup> The sole source of supply of the air heater elements known to the committee at this time is Watlow Air Heaters, Chicago, IL 708-490-3900.

<sup>14</sup> The sole source of supply of the airflow meter known to the committee at this time is Sierra Instruments, Inc., 5 Harris Ct., Monterey, CA 93940.



barrel as shown in [Annex A7](#). The location of the 1Y3977 humidity probe is shown in [Annex A8](#). The sample line might require insulation to prevent dropping below dew point temperature and shall not be hygroscopic. Drain taps may be installed at the low points of the combustion air system.

6.2.1.7 Use feedback-equipped controls to maintain filtered, compressed, and humidified inlet air at the conditions specified in [Annex A12](#).

6.2.2 *Exhaust System*—The exhaust system components from the cylinder head to the exhaust barrel are part of the basic 1Y3700 engine arrangement. These components consisting of an adapter, elbow, bellows, flange, and clamps can be found in the 1Y3700 Parts Book.

6.2.2.1 Purchase the 1Y3976 exhaust barrel (which is almost identical to the intake barrel except for the top cover) that has been specifically designed from one of the three approved manufacturers. Install the exhaust barrel at the location shown in [Annex A7](#). Do not add insulation to the barrel.

6.2.2.2 Install a restriction valve downstream from the exhaust barrel. The distance between the valve and barrel is not specified. The location of the exhaust thermocouple is shown in [Annex A2](#). Measure the exhaust pressure at the exhaust barrel shown in [Annex A7](#).

6.2.2.3 Use feedback-equipped controls to maintain the exhaust gases at the pressure specified in [Annex A12](#).

6.2.3 *Fuel System*—The fuel system schematic is shown in [Annex A5](#). Desired fuel injection timing is controlled by the engine computer at 13° BTC. Measure the fuel rate using micro motion device with a maximum range of 90 kg/h scaled to the 1P operation range specified in [Annex A12](#).<sup>15,11</sup> Use the day tank specified in [Annex A5](#). Measure fuel temperature at the fuel filter base as shown in [Annex A2](#) and control it using the cell facility feedback system. Use the required fuel heat exchanger(s) and arrange them as specified in [Annex A5](#). Use the Fisher regulator specified in [Annex A5](#).

6.2.4 *Oil Consumption System*—Use an oil scale system to accurately measure oil consumption (see [Fig. A6.2](#) and [Fig. A6.3](#)). The oil scale system shall have a resolution as listed in [Annex A2](#). Use flexible hoses similar to Aeroquip flexible hose, FC352-08, to-and-from the oil scale reservoir to eliminate measurement errors.<sup>16,11</sup> Use No.5 TFE-fluorocarbon, steel-braided hoses to and from the oil scale pumps. The hose length to-and-from the oil scale cart shall not exceed 2.7 m. Use the special oil pan adapter described in [Fig. A6.4](#).

6.2.5 *Engine Oil System*—A schematic of the oil system is shown in [Fig. A6.1](#). Measure oil pressure at the engine oil manifold (see [Annex A2](#)). An engine oil pressure sensor transmits a signal to the ECM that maintains oil pressure at 415 kPa. The ECM transmits a signal to an engine-mounted Mamac air pressure controller. The Mamac modulates the facility air pressure of 280 kPa to levels that vary between 0 kPa to 140 kPa and directs it to the normally closed Johnson Controls relief valve. Because the engine oil pressure sensor calibration might vary from the cell data acquisition transducer,

vary the oil pressure adjust signal to the ECM to maintain the oil pressure at the test specifications. See the Electronic Installation and Operation manual for additional information. The ECM maintains the oil pressure regardless of engine speed. Measure the oil temperatures at locations shown in [Annex A2](#).

6.2.5.1 *Oil Heating System*—Use an external oil heating system provided by the test facility to maintain the engine oil manifold temperature specified in [Annex A12](#). An example system is shown in [Appendix X1](#). A special 1Y3908 oil cooler bonnet has been designed to allow separate fluids to the engine coolant tower arrangement (see [Fig. A6.9](#)). Plug the 1Y3660 oil cooler adapter and 1Y3908 heat exchanger bonnet as shown in [Annex A6](#). Use Paratherm NF for the heating fluid.<sup>17,11</sup> The temperature of the Paratherm NF is measured by the thermocouple shown in [Annex A2](#).

6.2.5.2 *Oil Sample Valve*—Refer to [Annex A2](#) for the installation location and component makeup of the oil sample valve. Use of alternate equivalent components for the sample valve is permitted.

6.2.6 *Engine Coolant System*—The coolant system schematic is shown in [Annex A3](#). Control the coolant temperature out of the engine using a cell facility feedback system. Use a 1Y3898 Johnson Controls valve or equivalent fail-open valve to regulate the coolant temperature out of the engine as shown by the schematic in [Annex A3](#). If the 1Y3898 Johnson valve is used, supply facility air pressure at 280 kPa to the controller that regulates air pressure to the valve at 0 kPa to 140 kPa. Install a feedback-equipped control system to pneumatically adjust the valve. Remove the 1Y3832 hose originally supplied with the engine and install a sight glass using the components shown in [Annex A3](#).

6.2.7 *Engine Instrumentation*—Use feedback-equipped systems to control the engine operating temperatures, pressures, and flow rates. Measure the engine operating conditions at the locations shown in [Annex A2](#). For temperature measurements, use thermocouples 1Y468 (intake air), 1Y467 (engine exhaust) and 1Y466 (fluids-water, oil, and fuel) or equivalent thermocouples as specified in [Annex A2](#). Instrument measurement and reporting resolutions are shown in [Annex A2](#).

6.2.8 A dynamometer with feedback control to maintain engine torque and speed. Use a starting system capable of at least breakaway torque of 136 N·m and sustained torque of 102 N·m at 200 r/min.

6.2.9 Compressed air at 35 kPa to the top of the coolant tower as specified in [Annex A3](#) to ensure water does not boil out of the antifreeze mixture and result in less heat rejection from the engine.

6.2.10 Measure engine blowby downstream of the engine breather housing by measuring the delta pressure across an orifice or an equivalent device.

6.2.11 The crankcase pressure is above atmospheric pressure with this engine arrangement. Measure it at the location shown in [Annex A2](#).

<sup>15</sup> The sole source of supply of the apparatus known to the committee at this time is Micro Motion, Inc. 7070 Winchester Circle, Boulder, CO 80301.

<sup>16</sup> The sole source of supply of the flexible hose known to the committee at this time is Aeroquip Industrial Div, 1225 W. Main Street, Van Wert, OH 45891.

<sup>17</sup> The sole source of supply of the fluid known to the committee at this time is Paratherm NF Oil, Conshohocken, PA 19428.

6.3 Obtain information concerning the test engine, engine electronics system, new engine parts, replacement parts, and permissible substitution or replacement parts from Caterpillar, Inc.

6.4 Engine and parts warranty information can be found in **Annex A1**. Use the form listed in **Annex A9** for returning defective parts.

## 7. Reagents and Materials

7.1 *Purity of Reagents*—Reagent grade chemicals shall be used in all tests. Unless otherwise indicated, it is intended that all reagents conform to the specifications of the Committee on Analytical Reagents of the American Chemical Society where such specifications are available.<sup>18</sup> Other grades may be used, provided it is first ascertained that the reagent is of sufficiently high purity to permit its use without lessening the accuracy of the determination.

7.2 *Diesel Piston Rating Booth*, as described by ASTM Deposit Rating Manual 20.

7.3 *Diesel Piston Rating Lamp*, as described by ASTM Deposit Rating Manual 20

7.4 *Dispersant Engine Cleaner*.<sup>19,11</sup>

7.5 *Engine Coolant*—Use a 50/50 mixture of mineral-free water and Caterpillar brand coolant (P/N 8C684 for 3.8 L or 8C3686 for 208 L drum) for engine coolant. Mineral-free water is defined as water having a mineral content no higher than 34.2 mg/kg total dissolved solids. The coolant mixture may be reused for up to 1600 h. Keep the mixture at a 50:50 ratio as determined by using either Caterpillar testers 5P3514 or 5P0957 or an equivalent tester. Keep the coolant mixture contamination free. Total solids shall remain below 5000 mg/kg. Keep the additive level correct using Caterpillar test kit P/N 8T5296.

7.6 *Lead Shot*, commercial grade, approximately 5 mm in diameter.

7.7 *Light Grease*.

7.8 *Mobil EF-411*, available from ExxonMobil for engine assembly and calibration of the oil scale pump flow rates.<sup>20,11</sup>

7.9 *Paratherm NF*, as supplied by Paratherm and used as the fluid to heat the engine oil.<sup>17,11</sup>

7.10 *Pentane (Solvent)*, purity > 99 %, high-performance, liquid chromatography grade.

7.11 *Reference Oil*, as supplied by the TMC for calibration of the test stand.

7.12 *REO 217*, as supplied by the CRC and used when any copper components are changed.

7.13 *Sodium Bisulfate (NaHSO<sub>4</sub>)*, commercial grade.

7.14 *Solvent*—Use only mineral spirits meeting the requirements of Specification **D235**, Type II, Class C for Aromatic Content (0 % to 2 %) by vol, Flash Point (61 °C, min) and Color (not darker than + 25 on Saybolt Scale or 25 on Pt-Co Scale). (**Warning**—Combustible. Health hazard.) Obtain a Certificate of Analysis for each batch of solvent from the supplier.

7.15 *Fuel*—Obtain the required test fuel from Chevron Phillips<sup>21,11</sup> as PC-9-HS Reference Diesel Fuel (see **Annex A14**).

7.16 *Test Oil*—The total amount of oil needed for each lubricant test is approximately 42 L.

7.17 *Trisodium Phosphate (Na<sub>3</sub>PO<sub>4</sub>)*, commercial grade.

7.18 *5.4000 in. Ring Bore Standard Class Z Master*.<sup>22,11</sup>

## 8. Oil Samples

8.1 Take purge samples of 250 mL at 48 h, 72 h, 120 h, 144 h, 168 h, 192 h, 216 h, 264 h, 312 h, and 336 h. Following removal of each purge sample, remove a 30 mL sample, then add 317 g ± 10 g of new oil. It is not necessary to perform analysis on these samples of 30 mL. Use the purge sample to return to the full mark.

8.1.1 Take purge samples of 250 mL at 0 h (new) and 24 h, 96 h, 240 h, 288 h, and 360 h. Following removal of each purge sample, remove a 90 mL sample and add 370 g ± 10 g of new oil.

8.1.2 Analyze all 90 mL samples for viscosity by Test Method **D445** at 100 °C and 40 °C, TBN by Test Method **D4739**, TAN by Test Method **D664**, and the wear metals Al, Cr, Cu, Fe, Pb, Si by Test Method **D5185**. Analyze the samples for fuel dilution taken at 24 h, 240 h, and 360 h by Test Method **D3524**. See **Fig. A6.7** and **Fig. A6.8** for two graphical examples and a sample worksheet.

## 9. Preparation of Apparatus

9.1 *General Engine Assembly Practices*—As a part of good laboratory practice, inspect all components and assemblies that are exposed when the engine is disassembled and record the information for future reference. Inspect valve train components, bearings, journals, housings, seals and gaskets, and so forth and replace as needed. Assemble the engine with components and bolt torques as specified in the 1Y3700 engine Service Manual (see **Annex A10** for a partial list). It is the intent of this procedure for all engine assemblies and adjustments to be targeted to the mean of the specified values. Clean and lubricate the components in keeping with good assembly practices. Keep airborne dirt and debris to a minimum in the

<sup>18</sup> *Reagent Chemicals, American Chemical Society Specifications*, American Chemical Society, Washington, DC. For Suggestions on the testing of reagents not listed by the American Chemical Society, see *Annual Standards for Laboratory Chemicals*, BDH Ltd., Poole, Dorset, U.K., and the *United States Pharmacopeia and National Formulary*, U.S. Pharmacopeial Convention, Inc. (USPC), Rockville, MD.

<sup>19</sup> The sole source of supply of the engine cleaner known to the committee at this time is The Lubrizol Corp., 29400 Lakeland Blvd., Cleveland, OH 44092

<sup>20</sup> The sole source of supply of the oil known to the committee at this time is Mobil EF-411, from Golden West Oil Co., 3010 Aniol St., San Antonio, TX 78219.

<sup>21</sup> The sole source for IP fuel known to the committee at this time is Chevron Phillips Chemical Co., Chevron Tower, 1301 McKinney Street, Houston, TX 77010-3030.

<sup>22</sup> The sole source of supply of the apparatus known to the committee at this time is Morse-Hemco, 457 Douglas Ave., Holland, MI 49423.

assembly area. Maintain standard engine assembly techniques and practices (such as staggering piston ring gap positions, and so forth).

**9.2 Complete Engine Inspection**—Perform a complete engine inspection at intervals of 13 000 h. Ensure that wearing surfaces such as main bearings and journals, rod bearings and journals, camshaft bearings, valve train components, fuel system components, and so forth all are within manufacturer’s specifications. Refer to the 1Y3700 Service Manual for disassembly, assembly, inspections, and specifications. Paint crankcases as necessary with either Caterpillar yellow primer or red Glyptal.<sup>12,11</sup>

**9.3 Copper Components**—Anytime a copper part is replaced, run an engine test using REO 217 until two consecutive periods of 12 h show a stable copper level. To eliminate the need to perform this pacification process when replacing the engine oil cooler, use of a nickel-plated oil cooler is permitted.

**9.4 Engine Lubricant System Flush**—Flush the engine of used oil before every test. **Annex A11** shows the engine flush procedure and apparatus. A flushing instruction sheet shown in **Annex A11** gives the step-by-step process required for flushing. The 1Y3700 engine arrangement includes five flushing nozzles in the crankcase and front cover (see **Annex A11**). These nozzles are piped in parallel with the 1Y3935 filter flushing adapter (or equivalent) from a laboratory-provided manifold that pressurizes fluids supplied by a flush cart (see **Appendix X1**). Seal the gear train housing during flush with a 1Y3917 round plug with a 117-8801 o-ring as shown in **Annex A11**. Seal the crankcase using a 1Y3979 block flush cover with an internal bleed passage for the cam oil supply. Bolt a 1Y3980 plastic jet aiming fixture to the flush cover that is also used for flushing (see **Annex A11**). If the test oil is not available at engine assembly, Mobil EF411 oil may be substituted.

**9.5 Engine Piston Cooling Jets**—The piston cooling jets are flow-checked at the supplier and serialized to ensure proper performance, but the minimal rod clearances might result in jet movement during assembly. Verify proper jet flow positioning using EF-411 before each test with the 1Y3980 plastic jet aiming fixture and oil pressure to the manifold of 415 kPa. Record the cooling jet serial number.

**9.6 Engine Measurements and Inspections**—Measure and inspect the engine components prior to each test (see **Table A10.2** for partial specification list). Refer to the 1Y3700 Service Manual for information concerning component reusability and assembly not found in this procedure. The part numbers of components that need replacing are found in the 1Y3700 Parts Manual. Record the crankshaft angles at the specified maximum injector lift, exhaust, and intake maximum lift before each test using the reference listed in **Fig. A10.7**. Record component part numbers and serial numbers and other required measurements as shown in the test report. Inspect and reuse the rocker arm roller followers and camshaft lobe surfaces based on Caterpillar Service Publication SEBF8256.<sup>4</sup>

**9.7 Cylinder Head**—A reconditioned head is required for each test. Measurements after reconditioning shall be within specifications as shown in the 1Y3700 Service Manual. Do not

swap the cylinder head/jug assembly from test stand-to-test stand. Use the head/jug assembly used to calibrate the stand for all non-reference oil testing in that stand. **Fig. A10.1** shows the cylinder head nut torque sequence.

**9.8 Valve Guide Bushings**—Clean the valve guide bushings with a solvent and bristle brush prior to assembly. Lubricate the bushings and valve stems with Mobil EF-411 prior to assembly. See the 1Y3700 Service Manual for guide reusability specifications. Install new valve guide seals for each test.

**9.9 Fuel Injector**—Remove the fuel injector from the cylinder head before reconditioning commences. Refer to the 1Y3700 Service Manual for removal and assembly. Return defective fuel injectors to Caterpillar for warranty and failure-mode testing using the form listed in **Annex A9**.

**9.10 Piston and Rings**—Use a new piston (1Y3400 iron crown, 1Y3659 aluminum skirt) and new rings (1Y3802, 1Y3803, 1Y3804) for each test.

**9.10.1** Clean all three rings with pentane and a lint-free 100 % cotton towel.

**9.10.2** Measure the ring side clearances and ring end gaps for all three rings (see **Fig. A10.2** and **Table A10.1**). Keystone ring side clearance measurements require the ring to be confined in a dedicated slotted liner (see **Appendix X1**) or a ring gage<sup>15,11</sup> 137.16 mm in diameter. Measure the side clearances using four feeler gages of equal width and thickness of 0.01 mm at intervals of 90° around the piston. Measure the rectangular ring side clearance this way as well. Measure the minimum side clearance as specified in ASTM Deposit Rating Manual 20.

**9.10.3** Record the measurements for these parts before and after each test. Compare the measurements before the test and after the test to determine the amount of wear.

**9.10.4** Assemble the piston with the part number toward the camshaft.

**9.11 Cylinder Liner**—Use a new 1Y3805 or 1Y3997 cylinder liner for each test.

**9.11.1** After removing the protective oil/grease with mineral spirits (see **7.14**), clean the liner bore with a hot tap water and heavy-duty clothes washing detergent solution, then rinse with hot tap water.

**9.11.2** Measure and record the liner surface finish. The surface finish specification shown in **Fig. A10.3** does not apply to the 1Y3997 cylinder liner.

**9.11.3** Oil the liner bore with only Mobil EF-411. Assemble the cylinder liner, block and head with the torque specification shown in the 1Y3700 Service Manual or **Fig. A10.1**.

**9.11.4** Measure the liner with a dial bore gage to ensure that the out-of-round and taper conditions are within specified tolerances measured at seven intervals as shown in **Fig. A10.3**. Measure the cylinder liner projection using the modified indicator shown in **Fig. A10.4**.

**9.11.5** Torque the cylinder liner support ring using the procedure shown in **Fig. A10.5**.

**9.12 Compression Ratio**—Before starting each test, measure the piston-to-head clearance to ensure the proper compression ratio is used. Determine this dimension by using lead balls, each with a diameter of approximately 3.5 mm. Locate four



lead balls on the top of the piston at 90° intervals on the major and minor piston diameters. Hold them in place with light grease. With the piston near the top of the stroke, install the head and block assembly and torque to specifications. Turn the engine over top center by hand to compress the lead balls then remove the head and block assembly and measure the thickness of the lead balls to obtain the average piston-to-head clearance. The piston-to-head clearance specification is 1.62 mm ± 0.07 mm. Use multiple 1Y3817 block gaskets to adjust the clearance. If the piston-to-head measurement exceeds the tolerance specification, check the crankshaft main and rod journals, connecting rod and main bearings, and piston pin and rod bushing for excessive wear. The specified compression ratio for the 1Y3700 engine is 16.2 to 1.

9.13 *Engine Timing*—The engine ECM sets desired fuel injection timing to 13° BTC. Record this timing using the engine technician service tool. Mechanically time the actual engine components as shown in [Annex A10](#). Install the electronic sensors as shown in the Electronic Installation and Operation manual. Correctly assemble both the mechanical and electrical systems to produce the desired fuel timing.

9.14 *Engine Coolant System Cleaning Procedure*—Clean the coolant system when visual inspections show the presence of any oil, grease, mineral deposits, or rust following the procedure listed in [Annex A3](#).

9.15 After the engine components have been prepared and assembled, perform the following:

9.15.1 Fill the crankcase with 5800 g ± 50 g of test oil.

9.15.2 Install a new 1R0713 oil filter.

9.15.3 Fill the coolant system with coolant specified in Section 7.

9.15.4 Ensure the facility coolant to the engine heat exchanger is operational.

9.15.5 Pressurize the fuel system to remove air, then return the system to a non-pressurized state before starting engine.

9.15.6 Ensure all other systems and facilities are operational before starting the engine break-in.

## 10. Calibration and Standardization

10.1 *Test Cell Instrumentation*—Calibrate all facility read-out instrumentation used for the test immediately prior to subsequent stand calibration. Instrumentation calibration prior to subsequent stand calibration tests (that is, those that follow a failed or invalid first attempt) are at the discretion of the test laboratory. Refer to [Annex A2](#) for calibration tolerances and allowable *system* time constants.

10.2 *Instrumentation Standards*—Calibrate all temperature, pressure, flow, and speed measurement *standards* on a yearly basis. The calibration of all standards shall be traceable to a national bureau of standards. Maintain all calibration records for a minimum of two years.

10.3 *Coolant Flow*—Calibrate the coolant flow rate as follows: (1) calibrate the differential pressure transducer as outlined in [10.1](#) and [10.2](#) and, (2) replace the Barco venturi

every two years.<sup>23,11</sup> Use the following relationships as conversion factors from the differential pressure across the Barco venturi to liters per minute: 3.0 in. H<sub>2</sub>O = 24.3 L/min, 7.1 in. H<sub>2</sub>O = 37.8 L/min and 28 in. H<sub>2</sub>O = 75.7 L/min or use [Eq 1](#) where Δ*P* is measured in in. H<sub>2</sub>O.

$$L/min = \sqrt{\Delta P} 14.44 - 0.69 \quad (1)$$

10.4 *Re-calibration Requirements*—Re-calibration due to parts replacement is not required unless the engine crankcase or crankshaft, or both, require replacing or regrinding, or the crankshaft is removed for any other purpose besides bearing replacement, or the head/jug suffer a failure for any reason during the calibration period.

10.5 *Fuel Injectors*—The fuel injectors are calibrated during the manufacturing process. These fuel injectors can not be re-calibrated in the usual manner and require special test equipment to ensure proper flow, timing response, and spray patterns. Therefore, replace the fuel injector at the start of every calibration test (unless that test is the second of two required tests for a new stand or is a rerun of a previous calibration attempt). If the fuel injector is replaced on a calibrated stand, re-calibration is not required.

10.6 *Air Flow*—Install the Sierra Model 780 airflow meter to measure intake airflow. This meter should be calibrated yearly at a temperature of 60 °C. Measure the intake airflow during the break-in of every calibration test. Record the last value recorded during step five of the break-in as shown in [Annex A12](#).

10.7 *Intake Air Barrel*—Prior to each stand calibration test, inspect the intake air barrel for rust or debris. This may be done through either of the pipe flanges using a borescope or some other optical means.

10.8 *Fuel Filter*—Change the fuel filter before every calibration test.

10.9 *Oil Scale Flow Rates*—Verify the oil scale flow rates before the start of every calibration test using the procedure listed in [Annex A6](#).

10.10 *Calibration of Test Stands*—Use a blind calibration oil from the TMC to calibrate the engine stand. A stand calibration test is required every nine months. The calibration period begins on the start date of the acceptable calibration test. A test stand is considered calibrated when the test results are within the acceptability limits as published by TMC and the test is operationally valid. The TMC may request stand checks on calibration tests that fail to meet acceptability limits. If the calibration test is operationally valid, send the piston to another calibrated laboratory for a referee rating. The TMC issues a control chart analysis for each calibration test to the testing laboratory (see [Fig. A14.2](#)). The test stand is not considered calibrated if the calibration test was invalid or uninterpretable. Start any non-reference test prior to the expiration of the calibration period.

<sup>23</sup> The sole source of supply of the apparatus known to the committee at this time is Hyspan Precision Products, Inc., 1685 Brandywine Avenue, Chula Vista, CA 91911.



10.11 *Guidelines for Adjustments to Calibration Periods*—Reference oil test frequency may be adjusted for the following reasons:

10.11.1 *Procedural Deviations*—On occasions when a laboratory becomes aware of a significant deviation from the test method, such as might arise during an in-house review or a TMC inspection, the laboratory and the TMC shall agree on an appropriate course of action to remedy the deviation. This action might include the shortening of existing reference oil calibration periods.

10.11.2 *Parts and Fuel Shortages*—Under special circumstances, such as industry-wide parts or fuel shortages, the surveillance panel might direct the TMC to extend the time intervals between reference oil tests. These extensions shall not exceed one regular calibration period.

10.11.3 *Reference Oil Test Data Flow*—To ensure continuous severity and precision monitoring, calibration tests are conducted periodically throughout the year. There might be occasions when laboratories conduct a large portion of calibration tests in a short period of time. This could result in an unacceptably large time frame when very few calibration tests are conducted. The TMC can shorten or extend calibration periods as needed to provide a consistent flow of reference oil test data. Adjustments to calibration periods are made such that laboratories incur no net loss (or gain) in calibration status.

10.11.4 *Special Use of the Reference Oil Calibration System*—The surveillance panel has the option to use the reference oil system to evaluate changes that have potential impact on test severity and precision. This option is only taken when a program of donated tests is not feasible. The surveillance panel and the TMC shall develop a detailed plan for the test program. This plan requires all reference oil tests in the program to be completed as close to the same time as possible, so that no laboratory/stand calibration is left in an excessively long pending status. In order to maintain the integrity of the reference oil monitoring system, each reference oil test is conducted so as to be interpretable for stand calibration. To facilitate the required test scheduling, the surveillance panel might direct the TMC to lengthen and shorten reference oil calibration periods within laboratories such that the laboratories incur no net loss (or gain) in calibration status.

10.12 *Donated Reference Oil Test Programs*—The Surveillance Panel is charged with maintaining effective reference oil test severity and precision monitoring. During times of new parts introductions, new or re-blended reference oil additions, and procedural revisions, it might be necessary to evaluate the possible effects on severity and precision levels. The surveillance panel might choose to conduct a program of donated reference oil tests in those laboratories participating in the monitoring system, in order to quantify the effect of a particular change on severity and precision. Typically, the surveillance panel requests its panel members to volunteer enough reference oil test results to create a robust data set. Broad laboratory participation is needed to provide a representative sampling of the industry. To ensure the quality of the data obtained, donated tests are conducted on calibrated test stands. The surveillance panel shall arrange an appropriate number of donated tests and ensure completion of the test program in a timely manner.

10.13 *Test Run Numbering*—Number each test to identify the test stand number and the test run number. Number all runs sequentially. Append repeat calibration runs with a letter that is also sequential (that is, number the first rerun of test 45 as 46A, the second as 47B, and so forth). Maintain the letter suffix sequencing for each calibration test until the calibration has been accepted. Increment the run number for any test start.

10.14 *Humidity Calibration Requirements*—The accuracy of the laboratory's primary humidity measurement system shall be within  $\pm 0.6$  g of the humidity measuring chilled mirror dew point hygrometer or equivalent.

10.14.1 Calibrate the primary laboratory humidity measurement system within 48 h before the start of each stand calibration test or during the calibration test at each stand using a chilled mirror dew point hygrometer or equivalent with an accuracy of at least  $\pm 0.55$  °C at a dew point of 24 °C.

10.14.2 The calibration consists of a series of paired comparison measurements between the primary system and the chilled mirror dew point hygrometer or equivalent. The comparison period lasts from 20 min to 2 h with measurements taken at 1 min to 6 min intervals, for a total of 20 paired measurements. The measurement interval should be appropriate for the time constant of the humidity measuring instruments.

10.14.3 Ensure that the flow rate is within the equipment manufacturer's specification.

10.14.4 Take all measurements made with the dew point hygrometer or equivalent at atmospheric pressure and correct them to standard pressure conditions (101.12 kPa). Compute the difference between each pair of measurements and calculate the mean and standard deviation of the differences. The absolute value of the mean difference shall not exceed 0.6 g and the standard deviation shall be less than or equal to 0.3 g.

10.14.5 The primary humidity measurement system is deemed calibrated only if both of these requirements are met. If either of these requirements is not met, investigate the cause, make repairs, and recalibrate. Maintain the calibration data for a minimum of two years.

10.15 *Calibration of Piston Deposit Raters*—Each calendar year, each facility shall send at least one Heavy Duty Diesel Piston Rater to the ASTM Heavy Duty Piston Rating Workshop held every Fall. Each rater shall rate a minimum of six diesel pistons. If this schedule is not suitable to a particular rater or test laboratory, then make alternative arrangements as soon as possible to have the rater calibrated.

## 11. Procedure

11.1 *Engine Break-in Procedure*—Open any drain taps at the low points of the combustion air system (if they are installed) during the start of the break-in and warm-ups, and following any shutdowns.

11.1.1 The engine break-in and operational conditions are specified in [Annex A12](#). The total break-in time is 85 min. During the break-in, fix all leaks and make adjustments to ensure proper engine operation. Record the ECM personality module part number and release date.

11.1.2 After the break-in period and while the engine is hot, drain the oil from the crankcase, oil cooler, engine oil filter, and weigh scale for 30 min. Then weigh  $5800\text{ g} \pm 50\text{ g}$  of new test oil into the engine.

11.1.3 Start the engine, warm it up, and operate it for 360 h at the test conditions specified in step five of [Annex A12](#) with no oil changes.

11.1.4 Turn on the oil scale pumps once the engine has reached the beginning of Step 5 of the warm-up sequence. Record the oil mass in the oil scale as the full mark at the end of the fourth test hour. Throughout the test, record the oil scale reading at least once every 6 min.

11.1.5 Count test time from the moment the warm-up time is completed. The oil sample frequency is described in Section 8.

11.1.6 Do not remove the cylinder head, piston, or power assembly from the engine during a test.

11.1.7 Reinitialize engine timing calibration after the cam shaft/gear or cylinder head has been removed. See the electronic installation and operation manual. Complete this during the first step of the break-in.

11.2 *Cool-down Procedure*—Except for emergency (uncontrolled) stops, shut the engine down by operating it at conditions shown in Steps 4, 3, 2, and then 1 in [Annex A12](#).

11.3 *Warm-up Procedure*—Use the same procedure used for engine break-in to warm-up the engine for all subsequent starts throughout the test.

11.4 *Shutdowns and Lost Time*—Record the test hours, date, and length of off-test conditions for all occurrences. Record when the engine has early inspections or early test termination with the reasons for the occurrences. If the cool down procedure is not used, identify the shutdown as an *Emergency Shutdown*. A maximum allowed time of off-test conditions is 125 h. If the engine shuts down, immediately stop the oil scale pumps. In the event of an emergency shutdown, leave the engine shut down for 2 h (or more) to allow complete engine cool down before restarting. In order to limit foreign matter entering the combustion chamber and to protect piston deposits, rotate the engine to top dead center of the compression stroke during downtime.

11.5 *Periodic Measurements*—Record all engine conditions listed in Step 5 of [Annex A12](#) as a snapshot at least once every 6 min. Record humidity readings using the laboratory's primary humidity measurement system. Correct the recorded humidity values to standard pressure conditions of 101.12 kPa. Record the fuel position as indicated by the electronic technician at test hours 24, 240, and 360.

#### 11.6 *Engine Control Systems:*

11.6.1 *Engine Coolant*—Pressurize the coolant system to  $35.0\text{ kPa} \pm 7\text{ kPa}$  as shown in [Annex A3](#) to ensure the water does not boil out of the antifreeze. Manually adjust the coolant flow rate by turning the valve on top of the coolant tower to maintain the conditions specified in [Annex A12](#).

11.6.2 *Engine Fuel System*—Control the fuel rate by modifying the fuel limit adjusting the ECM using a facility controller that compares the actual fuel rate to the specified fuel rate listed in [Annex A12](#). See the Electronic Installation and

Operation manual for more details. Manually adjust the Fisher regulator to control fuel pressure. Maintain the fuel pressure and temperature as specified in [Annex A12](#).

11.6.3 *Engine Oil Temperature*—Maintain the oil manifold temperature to test specifications as shown in [Annex A12](#). The temperature of the Paratherm NF shall not exceed  $165\text{ }^\circ\text{C}$  at any time during break-in, warm-up, or testing. Shut off the external oil heater (but not its circulating pump) the moment the engine goes to cool-down.

11.6.4 *Exhaust Pressure*—Set the pressure as specified in [Annex A12](#) using a facility feedback-controlled restrictor valve.

11.6.5 *Intake Air*—Filter, compress, and humidify the inlet air to the conditions specified in [Annex A12](#). Heat (or cool, if necessary) the inlet air to the conditions in [Annex A12](#).

11.7 *Post-Test Procedures*—Remove the piston and ring assembly from the engine. Mark the location of the ring gaps on top of the piston.

11.7.1 *Piston Ring Side Clearances*—Measure the piston ring side clearances prior to removal of the rings to determine the level of deposit formation (see [Annex A10](#)). Align ring gaps to the EOT ring gap marks on the top of the piston. Do not force the feeler gages between the ring and groove to disturb or remove the deposits.

11.7.2 *Piston Ratings*—Immerse the piston assembly in mineral spirits (see 7.14) and air-dry it prior to any rating.

11.7.2.1 Process and measure the piston deposits according to the Modified CRC Diesel Piston Rating Method described in ASTM Deposit Rating Manual 20 modified by the directions listed in [Annex A13](#). Rate only two levels of carbon (heavy and light) on the second groove and all lands, and only one level of carbon (light) for the under-crown and cooling groove. Use a combined varnish rating method for the third groove, third land, fourth land, under-crown, and cooling groove (see [Annex A13](#)). An example rating worksheet is shown in [Appendix X1](#).

11.7.2.2 Another heavy-duty engine deposit rater shall verify all piston deposit ratings done by the testing laboratory. In special cases where another rater is not available, the rating may be verified by other qualified laboratory personnel. Record the initials of both the rater and the verifying rater.

11.7.3 *Referee Ratings*—The referee laboratory rates the entire piston. Wrap all pistons to be referee-rated in paper with ASTM desiccant chips. Then place them in plastic and seal before shipping to the referee laboratory. Report referee ratings to the TMC within ten days of EOT for calibration tests. Referee-rate piston deposits for all non-reference tests reviewed by Caterpillar.

11.7.4 *Ring End Gap Increase*—Remove all carbon from the rings. If scraping of the rings is necessary, use only a wooden instrument or equivalent. Measure and record the ring end gaps.

11.7.5 *Cylinder Liner Wear*—Use a surface profile measurement to determine the liner wear step in both transverse and longitudinal directions relative to the crankshaft. Remove deposits on the liner above the piston ring travel. Take transverse and longitudinal measurements at the wear step location approximately 13 mm from the top of the liner at four locations. Record the measurements as the liner wear step.

11.7.6 *Cylinder Liner Bore Polish*—Section the cylinder liner through the front and rear axis and measure the cylinder liner to determine the amount of bore polishing. Use the liner rating method listed in [Annex A13](#).

11.7.7 *Photographs*—Photograph the piston and rings showing the thrust, anti-thrust, front, rear, and undercrown positions (see [Appendix X1](#)). Place the rings on top of the piston to show ring gaps (thrust view) and 180° from gaps (anti-thrust view). Show the piston from the crown down to at least the bottom of the pin bore. Photograph the piston crown and skirt as one assembly. Photograph the bore ID of the sectioned liner (see [Appendix X1](#)).

## 12. Calculation or Interpretation of Results

12.1 *Test Validity Descriptions*—If a test was run for 360 h according to this test method, declare the test valid.

12.1.1 If a test was not run as specified by this test method, the test is operationally invalid. Some examples of an invalid test are: use of non-specified hardware, non-specified assembly methods, a test run whose downtime is greater than 125 h, and so forth. If a test without data acquisition on any controlled parameter has a gap greater than 4 h, the test is operationally invalid.

12.1.1.1 Conduct an engineering review when a control parameter QI value is below the threshold value of zero. A typical engineering review involves investigation of the test data to determine the cause of the below threshold QI. Other affected parameters may also be included in the engineering review. This can be helpful in determining if a real control problem existed and the possible extent to which it may have impacted the test. For example, a test runs with a low QI for fuel flow. An examination of the fuel flow data may show that the fuel flow data contains several over range values. At this point, an examination of exhaust temperatures may help determine whether the instrumentation problem affected real fuel flow versus affecting only the data acquisition.

(1) For reference oil tests, conduct the engineering review jointly with the TMC. For nonreference oil tests, optional input is available from the TMC for the engineering review.

(2) Determine operational validity based upon the engineering review and summarize the decision in the comment section on the appropriate form. It may be helpful to include any supporting documentation at the end of the test report. The final decision regarding operational validity rests with the laboratory.

12.1.2 If a test completes 360 h and the piston, rings, or liner exhibit distress, consider the test non-interpretable. Likewise, if the test is terminated *prior* to completing 360 h for reasons including purchaser request, excessive oil consumption, or piston, ring, or liner distress, then consider the test non-interpretable.

12.2 *Calculations*—Use the same set of data for all calculations and graphs in the test report.

12.2.1 *Quality Index*—Calculate and plot the Quality Index according to the instructions in [Annex A2](#).

12.2.2 *Oil Consumption*—Calculate oil consumption in grams per hour over intervals of 24 h. Delete the first 4 h of readings after an oil add from the linear regression. The linear

regression technique is shown in [Fig. A6.5](#) and [Fig. A6.6](#). Calculate the overall average oil consumption, the initial average oil consumption, and end-of-test (EOT) average oil consumption. The initial average is the average of the data points taken at the 24th hour and 48th hour from the oil consumption graph. The EOT average is the average of the data points taken at the 336th hour and 360th hour for a full length test, or for a short-term test it is the average of the last two data points from the oil consumption graph. Calculate the natural logarithmic transformation of the average and EOT oil consumption values using the following equations:

$$\text{transformed average oil consumption} = \ln(\text{average oil consumption}) \quad (2)$$

$$\text{transformed EOT oil consumption} = \ln(\text{EOT oil consumption}) \quad (3)$$

12.2.3 For a period of 24 h including a shutdown, calculate the oil consumption as follows:

12.2.3.1 Do not include the first oil mass amounts removed at 4 h after a shutdown in the linear regression.

12.2.3.2 Calculate the linear regression for the period before the shutdown.

12.2.3.3 Calculate the linear regression for the period after the shutdown.

12.2.3.4 Calculate a time-weighted average from both regressions to obtain the oil consumption for that 24 h period. For example, a test experiences a 7 h shutdown at test hour 12. The slope for the first period of 8 h (hour 4 to 12) is 10.7 g/h, and the slope for the second period of 8 h (hour 16 to 24) is 2.1 g/h. The weighted average is calculated as follows:

$$\text{weighted average} = \frac{(910.7 \text{ g/h})(8 \text{ h}) + (2.1 \text{ g/h})(8 \text{ h})}{8 \text{ h} + 8 \text{ h}} \quad (4)$$

## 13. Report

13.1 *Forms and Data Dictionary*—For reference oil tests, the standardized report forms and data dictionary for reporting test results and for summarizing the operational data are required. All report forms making up the 1P final report are available at the TMC website (<http://www.astmtmc.cmu.edu>). Report values for all the field names listed in the report forms. Some fields might be blank for short-term tests. Report all deposits, wear, and engine operational data as shown in the test report. The data dictionary defines the field lengths, decimal size, data type, units and format for the field names listed in the test report forms.

13.2 *Test Validity Reporting*—Mark whether the test is Valid, Invalid, or Non-interpretable where indicated in the test report. For a *valid stand calibration run*, report the test data to the TMC, and its engineers shall include the test data in the operationally valid database and determine statistical validity using the LTMS method. The LTMS method tracks the severity and precision of stand and laboratory test results. For a complete definition, refer to the LTMS manual that is available from the ASTM Test Monitoring Center.<sup>2</sup> For an *invalid or non-interpretable stand calibration run*, report the test data to the TMC with comments describing why the test is considered invalid or non-interpretable; the TMC shall not include these test data in the operationally valid database. All operationally invalid and non-interpretable calibration tests are reported by



**TABLE 1 Reference Oil Test Precision**

NOTE 1—These statistics are based on results obtained on Test Monitoring Center reference oils between Feb. 19, 1997 and Dec. 6, 2004.

Test Parameter	S <sub>IP</sub>	i.p.	S <sub>R</sub>	R
TGC—top groove carbon, demerits	7.90	22.12	7.99	22.37
WD—weighted piston deposits, demerits	44.9	125.7	46.5	130.2
TLC—top land carbon, demerits	10.08	28.22	10.13	28.36
OC—oil consumption, ln(OC) <sup>A</sup>	0.2660	0.7448	0.2772	0.7762
ETOC—end of test oil consumptions, ln(ETOC) <sup>B</sup>	0.4467	1.2508	0.4490	1.2572

Legend:

S<sub>i.p.</sub> = standard deviation for intermediate precision.

i.p. = intermediate precision.

S<sub>R</sub> = standard deviation for reproducibility.

R = reproducibility.

<sup>A</sup> This parameter is transformed using ln(OC). When comparing two test results on this parameter, first apply this transformation to each test result. Compare the absolute difference between the transformed results with the appropriate (intermediate precision, or reproducibility) precision limit.

<sup>B</sup> This parameter is transformed using ln(ETOC). When comparing two test results on this parameter, first apply this transformation to each test result. Compare the absolute difference between the transformed results with the appropriate (intermediate precision, or reproducibility) precision limit.

the TMC to the ASTM Single Cylinder Diesel Surveillance Panel in periodic testing summaries.

NOTE 1—For a *valid ACC Registered Oil Test*, report the data to the registration organization.<sup>24</sup> For an *invalid or non-interpretable ACC Registered Oil Test*, report the test data to the registration organization with supporting comments describing why the test is considered invalid or non-interpretable. When tests are presented to Caterpillar for review, include the data from all tests that were registered with the registration organization as part of the program.

### 13.3 Report Specifics:

13.3.1 If more than one fuel batch is used, report the fuel batch analysis that is most representative of the fuel in the tank.

13.3.2 Report any causes for any missing or bad test data in the comment section of the Downtime Summary form. If any alternative data acquisition method is used, document it as well.

13.3.3 If a calibration period is extended beyond the normal nine-month period, make a note in the comment section of the Downtime Summary form and attach a written confirmation from the TMC to the test report. List the outcomes of previous calibration runs in the comment section of the Downtime Summary form.

13.3.4 Attach to the test report the fuel analysis provided by the fuel supplier. For calibration tests, attach a copy of the TMC control chart analysis.

NOTE 2—It is recommended that test purchasers include the form shown in Fig. X1.8 when presenting the test results against specification limits, such as those in Specification D4485 or military specifications.

## 14. Precision and Bias

14.1 Test precision is established on the basis of reference oil test results (for operationally valid tests) monitored by the ASTM Test Monitoring Center. The data are reviewed semi-annually by the Single-Cylinder Diesel Surveillance Panel. Contact the ASTM TMC for current industry data.

14.1.1 **Table 1** summarizes reference oil intermediate precision and reproducibility of the test. The tabulated values are current as of Feb. 1, 2005. The Surveillance Panel updates these values as necessary.

14.1.2 *Intermediate Precision Conditions*—Conditions where test results are obtained with the same test method using the same test oil, with changing conditions such as operators, measuring equipment, test stands, test engines, and time.

NOTE 3—Intermediate precision is the appropriate term for this test method rather than repeatability which defines more rigorous within-laboratory conditions.

14.1.2.1 *Intermediate Precision Limit*—(i.p.)The difference between two results obtained under intermediate precision conditions that would, in the long run, in the normal and correct conduct of the test method, exceed the values shown in **Table 1** in only one case in twenty. When only a single test result is available, the Intermediate Precision Limit can be used to calculate a range (test result ± Intermediate Precision Limit) outside of which a second test result would be expected to fall about one time in twenty.

14.1.3 *Reproducibility Conditions*—Conditions where test results are obtained with the same test method using the same test oil in different laboratories with different operators using different equipment.

14.1.3.1 *Reproducibility Limit*—(R)The difference between two results obtained under reproducibility conditions that would, in the long run, in the normal and correct conduct of the test method, exceed the values shown in **Table 1** in only one case in twenty. When only a single test result is available, the Reproducibility Limit can be used to calculate a range (test result ± Reproducibility Limit) outside of which a second test result would be expected to fall about one time in twenty.

14.1.4 *Bias*—Bias is determined by applying an acceptable statistical technique to reference oil test results and when a significant bias is determined, a severity adjustment is permitted for non-reference oil test results (see TMC Memo 94-200, Lubricant Test Monitoring System document for details<sup>2</sup>).

## 15. Keywords

15.1 caterpillar 1P test procedure; oil consumption; piston deposits; single cylinder oil test

<sup>24</sup> Registration Systems, Inc., ACC Monitoring Agency, 4139 Gardendale, Suite 205, San Antonio, TX 78229.

## ANNEXES

### (Mandatory Information)

#### A1. ENGINE AND PARTS WARRANTY

A1.1 *Engine Warranty*—Caterpillar Inc. warrants single cylinder test engines sold by it to be free from defects in material and workmanship for a period of 12 months starting from the date of delivery to the first user. If a defect in material or workmanship is found during the warranty period, Caterpillar provides the replacement parts to be installed by the user. There is no charge to the user for parts furnished by Caterpillar. User at its own expense, shall return all defective parts to Caterpillar at Caterpillar's request. User is responsible for giving Caterpillar timely notice of a warranty failure. User is also responsible for labor costs and any applicable local taxes. Caterpillar is not responsible for failures resulting from abuse, neglect, and/or improper repair. **THIS WARRANTY IS EXPRESSLY IN LIEU OF ANY OTHER WARRANTIES, EXPRESSED OR IMPLIED, INCLUDING ANY WARRANTY OF MERCHANTABILITY OR FITNESS FOR PARTICULAR PURPOSE. REMEDIES UNDER THIS WARRANTY ARE LIMITED TO THE PROVISION OF PARTS AS SPECIFIED HEREIN. CATERPILLAR IS NOT RESPONSIBLE FOR INCIDENTAL OR CONSEQUENTIAL DAMAGES.**

A1.2 *Engine Parts Warranty*—All parts for the 1Y3700 engine that are nonconforming by reason of faulty manufacture should be discussed with Engine System Technology Development (ESTD).

A1.2.1 The test laboratories should contact ESTD (R.A. Riviere, Telephone: 309-636-5247, Fax: 309-675-1598) when they believe a part is nonconforming:

A1.2.2 ESTD determines if they want the part returned, or provide warranty without viewing the part.

A1.2.3 If ESTD determines that the part is nonconforming without viewing the part, the test laboratories will be asked to return the part to their Caterpillar dealer. ESTD will contact the Dealer and let them know the part is coming and to provide warranty for it.

A1.2.4 If ESTD wants to view the part, they issue a Return Goods Authorization No. (RGA) to the test laboratory. The laboratory fills out the form shown in **Annex A9** and sends the part and the form to Caterpillar Inc., Tech Center TC-L, Wing 4 - Rm 406, 14009 Old Galena Rd., Mossville, IL 61552, Att: A.C. Hahn.

A1.2.5 The test laboratories should fax a copy of the RGA claim form to Caterpillar Inc., Tech Services Div., Tech Center Bldg L, Fax: 309-578-4232, Att: A.C. Hahn.

A1.2.6 If ESTD determines that the part is nonconforming, they contact the dealer for the test laboratory and have the dealer provide warranty.

A1.2.7 A sample of the RGA claim form is shown in **Annex A9** and should include: return goods authorization no., part name, hours on the part, part no., quantity, engine serial no., date purchased, test laboratory that purchased the part and contact person's name, phone, fax, and address, dealer's name that sold the part, measurements or photographs, or both, to document the nonconformance.

#### A2. INSTRUMENT LOCATIONS, MEASUREMENTS, AND CALCULATIONS

A2.1 **Tables A2.1-A2.6** and **Figs. A2.1-A2.5** provide detailed information.

##### A2.2 *Requirements for the Quality Index Calculation:*

A2.2.1 Round the recorded values in accordance with the specifications listed in **Table A2.5**.

A2.2.2 Use the values listed in **Table A2.6** for all calculations.

A2.2.3 Use data taken at 6 min to calculate the Quality Index.

A2.2.4 Reset data that is greater than the high values listed in **Table A2.6** from the Over and Under Range Values column to the high value for that particular parameter.

A2.2.5 Reset data that is less than the low values listed in **Table A2.6** from the Over and Under Range Values column to the low value for that particular parameter.

A2.2.6 Round the Quality Index values to the nearest 0.001.

A2.2.7 Report Quality Index values on Form 2 of the test report.

NOTE A2.1—Refer to the DACA II Final Report for calculating the Quality Index involving the loss of test data or bad quality test data.

A2.3 Formula to calculate the Quality Index:

$$QI = 1 - \frac{1}{n} \sum \left( \frac{U+L - 2X_i}{U-L} \right)^2 \quad (A2.1)$$

where:

- $X_i$  = recorded test measurement parameter,
- $U$  = upper specification for that parameter,
- $L$  = lower specification for that parameter, and

$n$  = total number of data points taken as determined from test length and procedural specified sampling rate.

**TABLE A2.1 Instrument Locations**

Parameter	Data Acquisition and Control	Engine Computer Sensors	Facility Feedback Control (if separate sensor is required)
Cam speed and timing sensor		A	
Crankshaft speed and timing sensor		B	(at dyno)
Coolant pressure to jug	1		
Coolant temperature to jug	2		
Oil temperature to cooler	3		
Atmospheric pressure		C	
Crankcase pressure	4	D	
Facility air pressure to cooling tower	5		
Oil manifold temperature	6	E	6 or W
Oil sampling valve	7		
Oil manifold pressure	8	F	
Coolant temperature from engine	9	H	9 or X
Coolant pressure from engine		G	
Coolant flow barco delta pressure	10		
Air inlet manifold pressure	(at barrel)	I	(at barrel)
Air inlet manifold temperature	11		11 or Y
Fuel temperature from filter	Z		12
Fuel pressure from head	13		
Fuel flow rate	(at micro motion)		(at micro motion)
Exhaust manifold temperature	14	J	
Exhaust manifold pressure	(at barrel)		(at barrel)
Humidity	(at barrel)		(at barrel)
Air flow rate	(at meter)		
Blowby flow rate	(at meter)		

**TABLE A2.2 Thermocouple Diameters, Lengths and Immersion Depths**

Location	Diameter, mm	Length, mm, max	Depth, mm $\pm 3$ mm
Oil to manifold	not applicable	152	22
Oil to cooler	not applicable	152	27
External heating oil	not applicable	152	27
Coolant in	not applicable	152	40
Coolant out	not applicable	152	26
Inlet air	not applicable	152	57
Exhaust	not applicable	152	67
Fuel	not applicable	152	34



**TABLE A2.3 Calibration Tolerances**

Parameters	Tolerance
Torque	not applicable due to differences within the industry; TMC will verify each laboratory it visits
Fuel flow rate	0.4 g/min
Air flow rate	± 2 % of reading from 10-100 % of calibrated range; ± 0.5 % of FS below 10 % of calibrated range
Humidity	listed in this test method
<b>Temperatures</b>	<b>°C</b>
Fuel at filter	0.5
Coolant to jug	0.25
Coolant from engine	0.25
Oil to cooler	0.5
Oil manifold	0.5
External heating oil	0.5
Air inlet manifold	0.5
Exhaust manifold	1.0
<b>Pressures</b>	<b>kPa</b>
Fuel from head	0.7
Oil manifold	0.7
Air inlet	0.3
Exhaust	0.3
Crankcase	0.02

**TABLE A2.4 Maximum Allowable System Time Constants**

Measurements	Time, s
Speed	3.0
Fuel flow rate	20.0
Air flow rate	3.0
Oil mass	TBD
<b>Temperatures</b>	
Fuel at filter	3.0
Coolant to jug	3.0
Coolant from engine	3.0
Oil to cooler	3.0
Oil manifold	3.0
External heating oil	3.0
Air inlet manifold	3.0
Exhaust manifold	3.0
<b>Pressures</b>	
Fuel from head	3.0
Oil manifold	3.0
Air inlet	3.0
Exhaust	3.0
Crankcase	3.0

**TABLE A2.5 Measurement and Reporting Resolutions**

Parameter	Units	Tol	Specification	Minimum Measurement Resolution	Round Values to the Nearest Whole Number
Speed	r/min	±3	1800	1	whole number
Power	kW	approximately	55	0.1	tenth
Torque	N·m	approximately	285	0.1	tenth
Fuel rate	g/min	±1	185	0.1	tenth
Fuel timing	BTC		13		
Humidity	g/kg	±1.7	17.8	0.1	tenth
Oil mass	g			2	whole number
<b>Temperatures °C</b>					
Fuel into head		±3	42	0.1	tenth
Coolant into jug		approximately	86	0.1	tenth
Coolant from head		±3	90	0.1	tenth
Oil to cooler		approximately	128	0.1	tenth
Oil manifold		±3	130	0.1	tenth
External heating oil			165 max	0.1	tenth
Inlet air manifold		±3	60	0.1	tenth
Exhaust manifold		approximately	480	1	whole number
<b>Pressures kPa</b>					
Fuel from head		±20	275	1	whole number
Coolant into jug		approximately	81	1	whole number
Oil manifold		±20	415	1	whole number
Inlet air barrel (abs)		±1	272	0.1	tenth
Exhaust barrel (abs)		±1	265	0.1	tenth
Crankcase		approximately	0.10	0.01	hundredth
<b>Flows</b>					
Coolant	L/min	±2	75	0.1	tenth
Blowby	L/min	approximately	35	1	whole number
Air	kg/h	approximately	315	0.1	tenth

**TABLE A2.6 Quality Index Calculation Values and Plotting Axis Scale Definitions**

Controlled Parameters	units	Quality Index U and L Values <sup>A</sup>		Over and Under Range Values <sup>B</sup>		Plot Axes Ranges <sup>C</sup>		increment
		L	U	low	high	min	max	
Speed	r/min	1798.530	1801.470	1710	1890	1770	1830	10
Fuel flow	g/min	183.970	186.030	125	245	175	200	5
Humidity	g/kg	16.780	18.820	5	21	5	40	5
Coolant flow	L/min	73.060	76.940	0	82	60	90	5
Coolant out temperature	°C	89.379	90.622	55	125	70	110	5
Oil to Manifold Temperature	°C	128.798	131.202	60	200	120	150	5
Inlet air temperature	°C	59.360	60.640	20	100	50	70	5
Fuel into head temperature	°C	40.885	43.116	0	75	30	60	5
Oil to manifold pressure <sup>D</sup>	kPa	404.384	425.616	0	690	380	450	10
Inlet air pressure	kPa	271.449	272.551	242	302	265	280	5
Exhaust pressure	kPa	264.150	265.850	215	315	250	280	5
Fuel pressure	kPa	271.471	278.529	125	425	230	300	10
Uncontrolled Parameters								
Power	kW					50	60	1
Torque	N·m					230	310	10
Blowby	L/min					5	65	5
Coolant in temperature	°C					75	100	5
Coolant delta	°C					0	10	1
Oil cooler in temperature	°C					120	140	5
Heating oil temperature	°C					120	165	5
Exhaust temperature	°C					450	500	10
Crankcase pressure	kPa					0.0	1.5	0.1
Coolant pressure	kPa					60	95	5

<sup>A</sup> The threshold for operational validity is 0.00.

<sup>B</sup> Only to be used in the calculation of Quality Index and Average and does not affect how process is graphed.

<sup>C</sup> Quality Index Scales are to range from -0.3 to 1.0 with increments of 0.1. The axis for test time is 0 h to 360 h in increments of 30 h. X-axis length should be at least 203 mm; Y-axis length should be at least 140 mm.

<sup>D</sup> Oil pressure operating specifications apply only to 15W-40 oils. Attempt to maintain these limits for all oils. When oils other than 15W-40 oils fall outside these limits, explain these deviations from the limits in the comments section of the test report.



See A2.1 for Legend

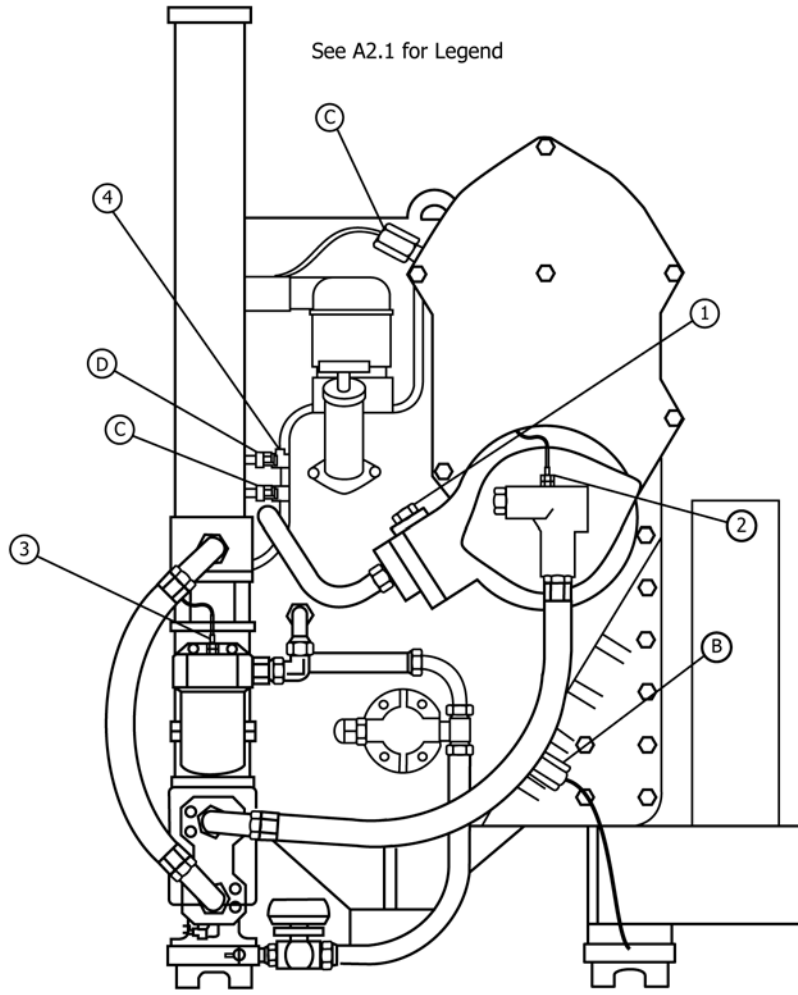

FRONT VIEW

FIG. A2.1 Instrument Locations—Engine Front View

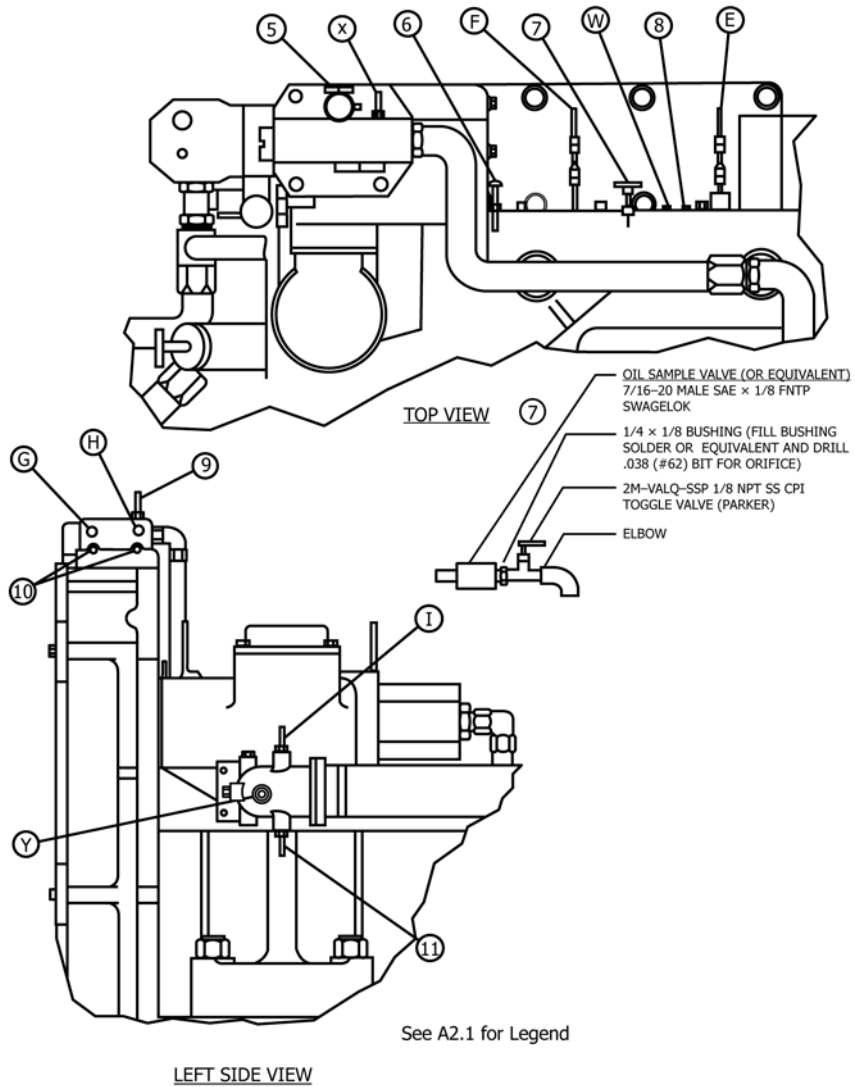

LEFT SIDE VIEW

FIG. A2.2 Instrument Locations—Top and Left Engine Views

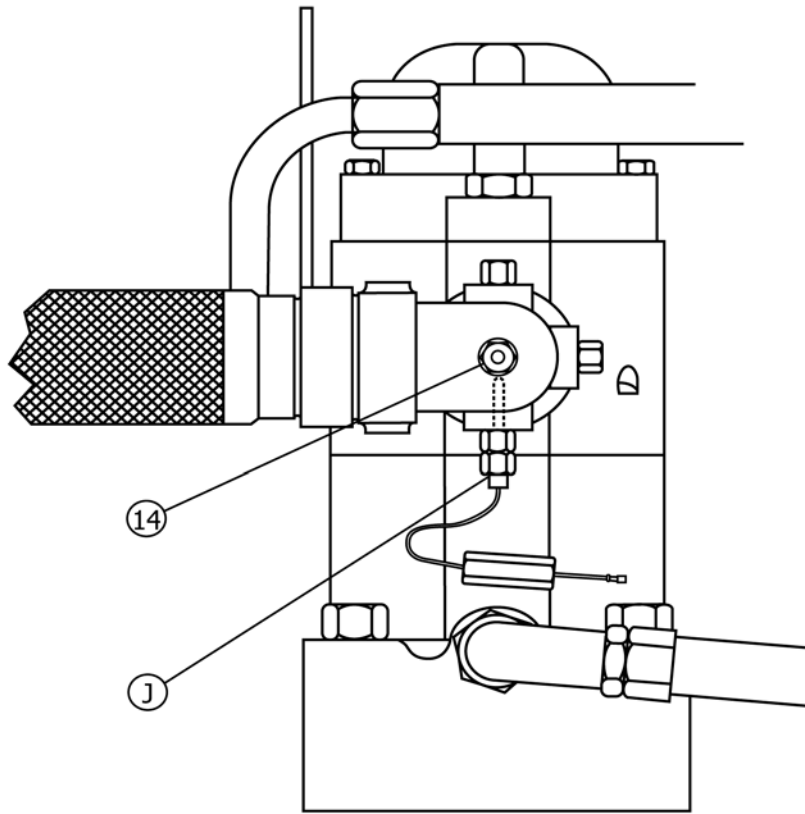

RIGHT SIDE VIEW  
See A2.1 for Legend

FIG. A2.3 Instrument Locations—Right Engine View

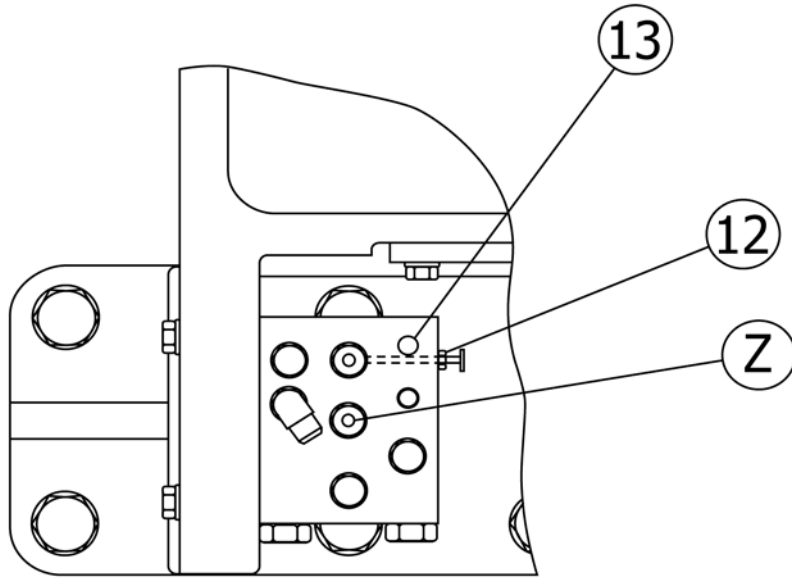

TOP VIEW

See A2.1 for Legend

FIG. A2.4 Instrument Locations—Top Engine View



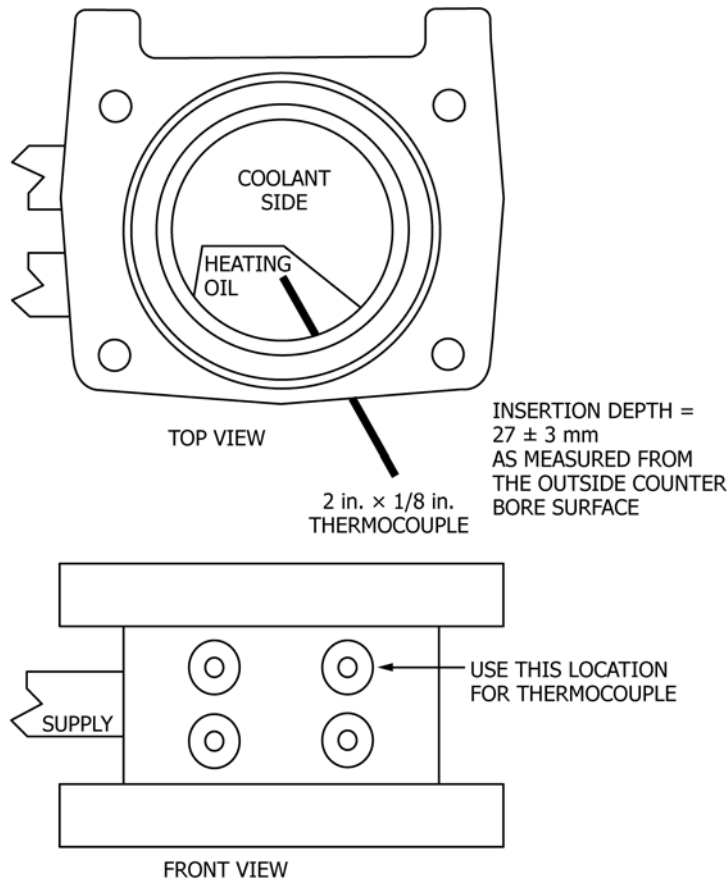

NOTE 1—Turn oil filter block drain valve 180° so that it is facing out and easier to use.

FIG. A2.5 Engine Heating Oil Thermocouple Location

### A3. COOLING SYSTEM ARRANGEMENT

A3.1 Install a sight glass as shown using the following components listed in [Table A3.1](#).

A3.1.1 Reuse one of the straight 37° flare swivel hose fittings on the existing hose for the tower side of assembly. The 90° fitting in the cylinder head is also still used. Installation angle will be slightly different.

A3.2 *Cleaning Procedure for the Engine Coolant System*—Clean the coolant system when visual inspections show the presence of any oil, grease, mineral deposits, or rust. The engine cooling system arrangement is shown in [Fig. A3.1](#).

A3.2.1 To remove oil and grease from the cooling system:

A3.2.1.1 Operate the engine until oil and water operating temperatures are attained; shutdown the engine and drain the cooling system.

A3.2.1.2 Fill the cooling system with a solution of 454 g of trisodium phosphate ( $\text{Na}_3\text{PO}_4$ ) to 38 L of water; operate the engine for 5 min to ensure complete mixing of the solution with any material remaining from the previous fill.

A3.2.1.3 Shutdown the engine and drain and flush the engine with fresh water and drain the water from the system.

A3.2.2 To remove mineral deposits from the cooling system:

A3.2.2.1 Operate the engine until oil and water operating temperatures are attained; shutdown the engine and drain the cooling system.

A3.2.2.2 Fill the cooling system with a solution of 454 g of commercial sodium bisulfate ( $\text{NaHSO}_4$ ) to 19 L of water; then run the engine at operating temperatures for 30 min.

A3.2.2.3 Shutdown the engine, drain and flush the engine with fresh water and drain the water from the system.

A3.2.2.4 Fill the cooling system with a solution of 454 g of trisodium phosphate ( $\text{Na}_3\text{PO}_4$ ) to 38 L of water; operate the engine for 5 min to ensure complete mixing of the solution with any material remaining from the previous flush.

A3.2.2.5 Shutdown the engine and drain the engine, flush with clear water and drain after flushing.

A3.2.2.6 Disassemble the engine and prepare for the next test.

TABLE A3.1 Coolant Sight Glass Components

Item	Quantity	Part No.	Source	Description	Location
1	1	2061-20-20S	Aeroquip	45° SAE O-ring port to 37° flare	inlet to top of coolant tower
2	1	190265-20S	Aeroquip	45° Elbow – SAE O-ring to 37° flange swivel	head outlet
3	2	412-16-20S	Aeroquip	Male pipe re-usable fitting	inlet and outlet of sight glass
4	1	4288 1 in. NPT Female	Gits <sup>A</sup>	style OL flow gage (sight glass)	locate in middle of hose assembly
5	1	FC350-20	Aeroquip	hose ~ 140 mm	head side of assembly
6	1	FC350-20	Aeroquip	hose ~ 165 mm	tower side of assembly

<sup>A</sup> Gits Manufacturing Co.

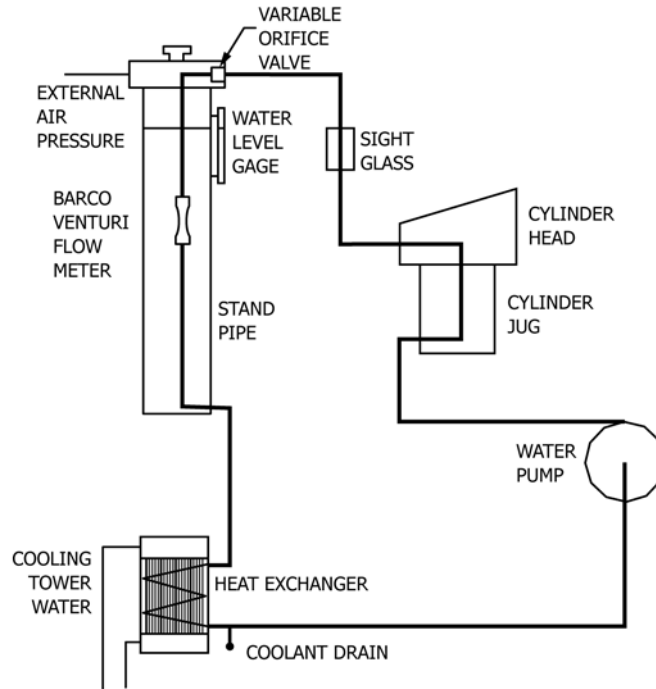
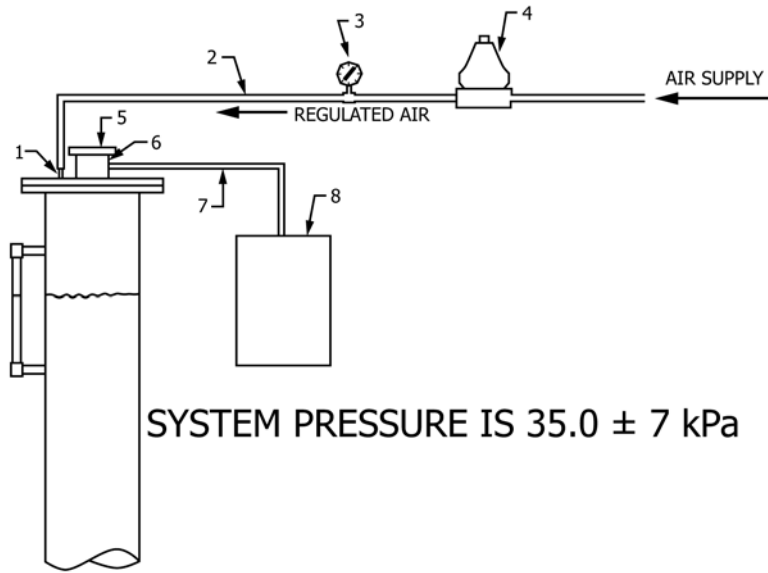

FIG. A3.1 Engine Cooling System Arrangement

A3.2.3 If the cooling system is contaminated by oil and mineral deposits, remove the oil from the system, then remove the mineral deposits. Alternatively, the cylinder head coolant passages may be cleaned after the head is removed.

A3.2.4 The coolant pressurization system is shown in Fig. A3.2 and the cooling tower water circuit is shown in Fig. A3.3.



NOTE 1—Legend:

- 1. 1/4 in. NPT-to-No.4AN (male connector)
- 2. No. 4 hose
- 3. Pressure gage 0 kPa to 103 kPa
- 4. Pressure regulator (self bleeding)
- 5. Radiator cap 105 kPa to 110 kPa
- 6. Radiator filler neck
- 7. Overflow tube (optional)
- 8. Overflow tank (optional)

FIG. A3.2 Coolant Pressurization System

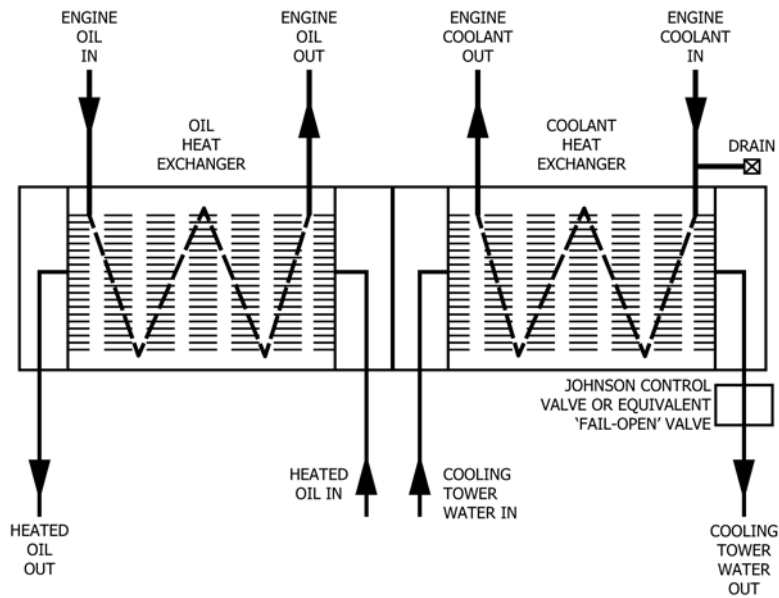
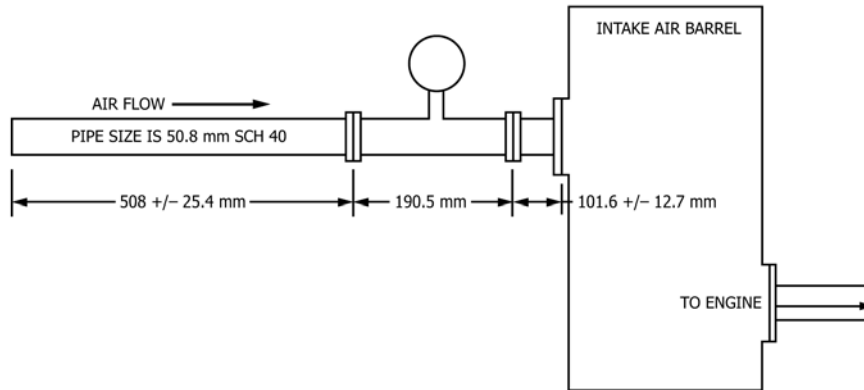

FIG. A3.3 Cooling Tower Water Circuit

A4. INTAKE AIR MASS FLOW SENSOR INSTALLATION

A4.1 The intake air sensor installation is shown in Fig. A4.1.



NOTE 1—Meter: Model 780 in-line mass flow meter by Sierra Instruments;  
 Accuracy:  $\pm 2\%$ ;  
 Part No.: (780-F6-CG-other options).

FIG. A4.1 Intake Air Sensor Installation

A5. FUEL SYSTEM DESIGN AND REQUIRED COMPONENTS



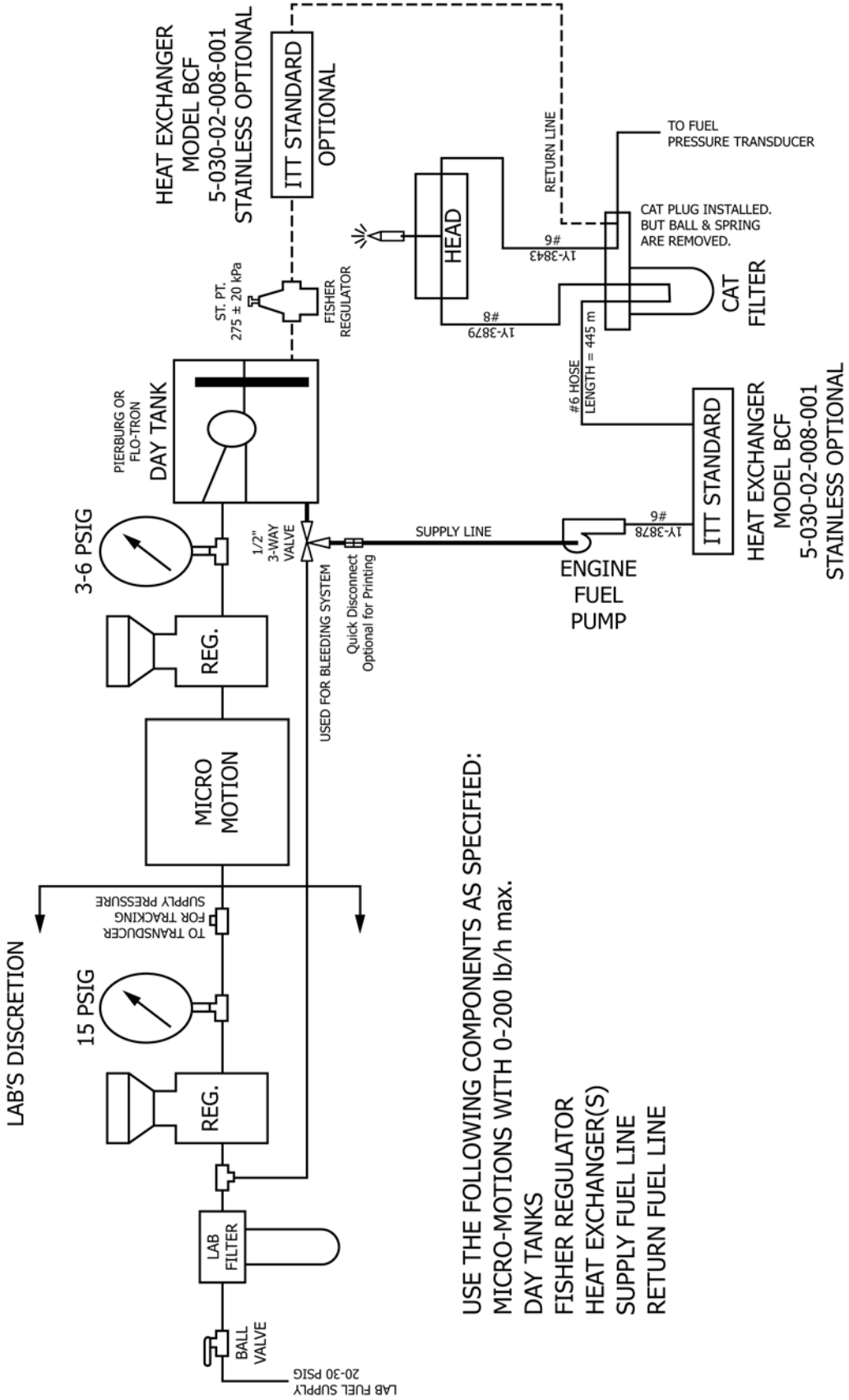

USE THE FOLLOWING COMPONENTS AS SPECIFIED:  
 MICRO-MOTIONS WITH 0-200 lb/h max.  
 DAY TANKS  
 FISHER REGULATOR  
 HEAT EXCHANGER(S)  
 SUPPLY FUEL LINE  
 RETURN FUEL LINE

SUPPLY FUEL LINE IS FC300-10 AEROQUIP (ID=5") HOSE OR 1/2" STAINLESS STEEL TUBING  
 RETURN FUEL LINE IS FC300-06 AEROQUIP (ID=5/16") HOSE OR 5/16" STAINLESS STEEL TUBING

FIG. A5.1 Fuel System Design and Required Components

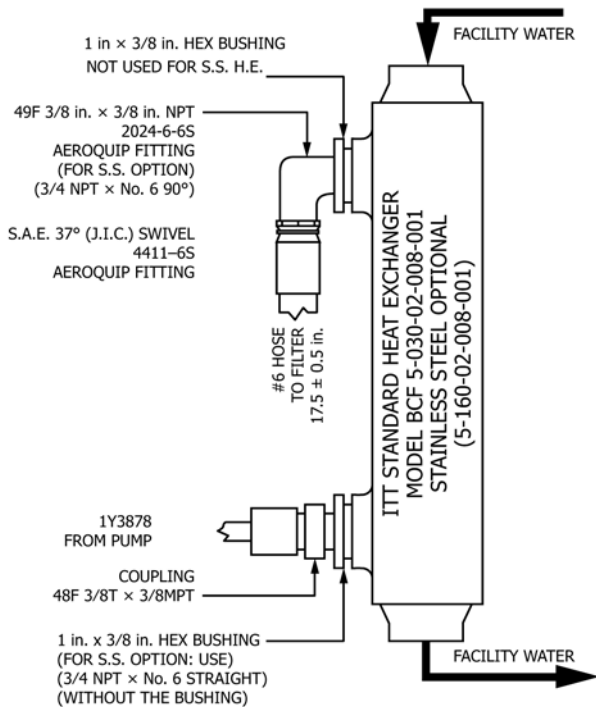

FIG. A5.2 Fuel Heat Exchanger Plumbing Connections

TABLE A5.1 Fisher Regulator Information

NOTE 1—Information as it appears on regulator tag.

Type	Pressure Units	Inlet, max	Spring Range	Trim Material	Allowable Inlet Pressure, max
H-17	PSIG	75	22-75	SST	250

## A6. OIL SYSTEM

A6.1 *Oil Scale System*—Additional information about the oil scale system is provided by Figs. A6.1-A6.4.

A6.2 *Oil Consumption Linear Regression Method*—If there is good reason to assume that a variable  $Y$  is dependent upon another variable  $X$  and that the relationship is linear, the best-fit line describing this relationship can be plotted using the following equations. Also see Figs. A6.5 and A6.6.

$$m = \frac{\sum x_i y_i - \frac{\sum x_i \sum y_i}{n}}{\sum x_i^2 - \frac{(\sum x_i)^2}{n}} \quad (A6.1)$$

$$b = \left[ \frac{\sum y_i}{n} - m \frac{\sum x_i}{n} \right] \quad (A6.2)$$

$$r^2 = \frac{\left[ \sum x_i y_i - \frac{\sum x_i \sum y_i}{n} \right]^2}{\left[ \sum (x_i)^2 - \frac{(\sum x_i)^2}{n} \right] \left[ \sum (y_i)^2 - \frac{(\sum y_i)^2}{n} \right]} \quad (A6.3)$$

where:

- $y_i$  = oil mass removed at time  $x$ ,
- $x_i$  = times at which oil mass observations  $x$  are made,
- $m$  = slope of best-fit line = oil consumption,
- $b$  =  $y$  intercept, and
- $r^2$  = goodness of fit (1 if perfect, 0 if not fit at all).

### A6.3 Oil Sampling Procedure:

A6.3.1 Record oil scale reading at test hour four \_\_\_\_\_ g. This is the *Full Mark*.

A6.3.2 Record the *oil mass* from the 24th hourly reading \_\_\_\_\_ g.

A6.3.3 Remove purge sample of 250 mL from sample valve on the oil manifold.

$$\frac{\text{purge+container}}{\text{container}} = \frac{g}{\text{purge}}$$

A6.3.4 For test hours 24, 96, 240, 288 and 360, remove a sample of 90 mL from the sample valve on the oil manifold.

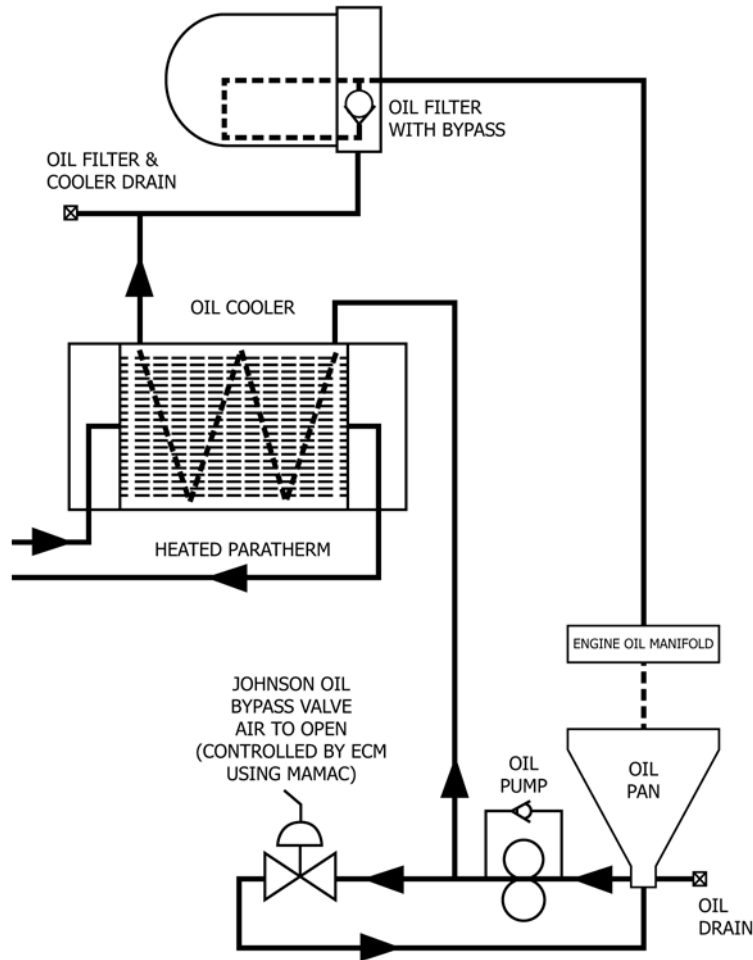

FIG. A6.1 Oil System

$$\frac{\text{sample} + \text{container}}{\text{sample} + \text{container}} - \frac{\text{container}}{\text{container}} = \frac{g}{\text{sample}}$$

A6.3.4.1 Add 370 g ± 10 g of *NEW test oil* to the oil weigh tank.

$$\frac{\text{new oil} + \text{container}}{\text{new oil} + \text{container}} - \frac{\text{container}}{\text{container}} = \frac{g}{\text{new oil}}$$

A6.3.5 For *test hours* 48, 72, 120, 144, 168, 192, 216, 264, 312 and 336, remove a sample of 30 mL from the sample valve on the oil manifold.

$$\frac{\text{sample} + \text{container}}{\text{sample} + \text{container}} - \frac{\text{container}}{\text{container}} = \frac{g}{\text{sample}}$$

A6.3.5.1 Add 317 g ± 10 g of *NEW test oil* to the oil weigh tank.

$$\frac{\text{new oil} + \text{container}}{\text{new oil} + \text{container}} - \frac{\text{container}}{\text{container}} = \frac{g}{\text{new oil}}$$

A6.3.6 Add back enough purge sample to return the oil weigh tank to its Full Mark using the following formula:

$$\text{purged to be returned} = FM - A \quad (\text{A6.4})$$

where:

$$A = \frac{\#2; 24\text{th Hourly Reading}; (\text{Scale Mass}) - \#3; \text{Purge Mass}}{-\#4; \text{Sample Mass}; (\text{if taken}) + \#5; \text{New Oil Mass}}$$

A6.3.7 Record the mass of *unused* purge sample by using scale.

$$\frac{\text{unused purge} + \text{container}}{\text{unused purge} + \text{container}} - \frac{\text{container}}{\text{container}} = \frac{g}{\text{unused purge left over}}$$

NOTE A6.1—If you are short in returning to the full mark, use fresh oil to make up the difference.

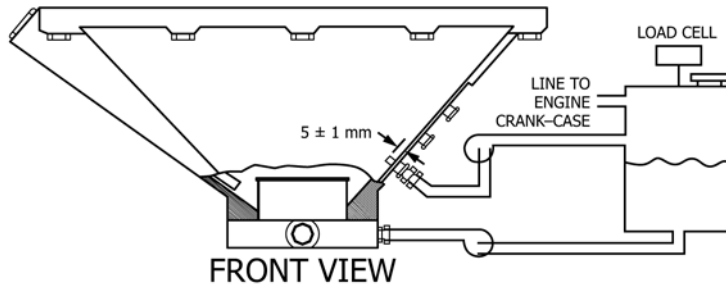
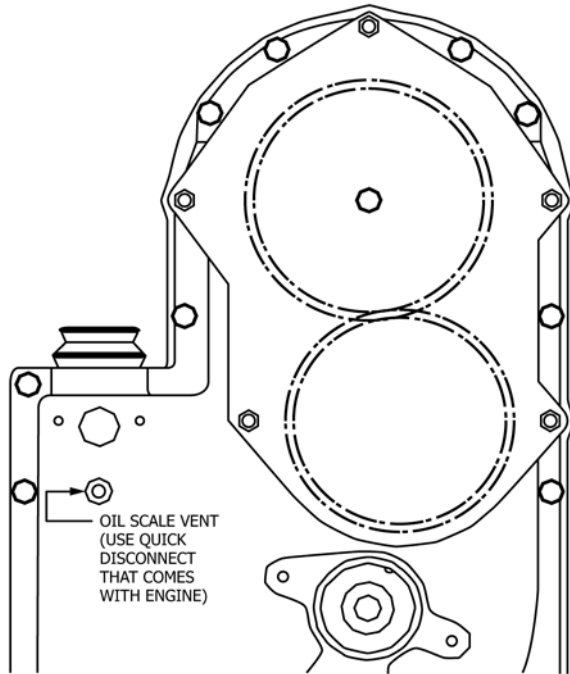
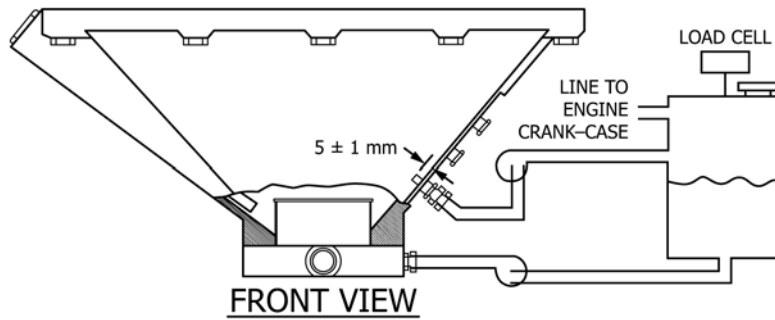

FIG. A6.2 Oil Scale Measurement System





NOTE 1—(1) Suction Hose or equivalent):

TFE-fluorocarbon steel braided, ID 6.4 mm, maximum length, 2.74 m

(2) Return Hose or equivalent):

TFE-fluorocarbon steel braided, ID 6.4 mm, maximum length 2.74 m

(3) Pump—(Use appropriate pumps) to achieve 23.6 kg/h to 24.9 kg/h suction and 16.3 kg/h to 17.7 kg/h return flow. Viking Model SG-041825-EO has been found to be suitable.)

(4) Pump Motor (or equivalent):

Type: 56 Nema Grainger 6K949

Speed: 1140 r/min

Power: 0.56 kW

(5) Vent Line: hose ID 6.35 mm

(6) Oil in Reservoir: 1000 g (approximately)

(7) Scale Precision: See Procedure

(8) Flexible Hose: (to and from fixed external sump support) (or equivalent): Aeroquip FC352-08

FIG. A6.3 Low Flow Oil Scale System

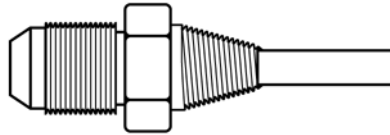

FIG. A6.4 Oil Pan Suction Fitting to Oil Scale

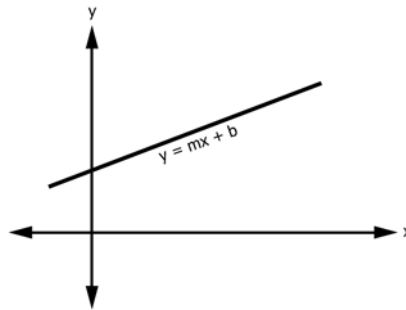

FIG. A6.5 Equation of a Straight Line

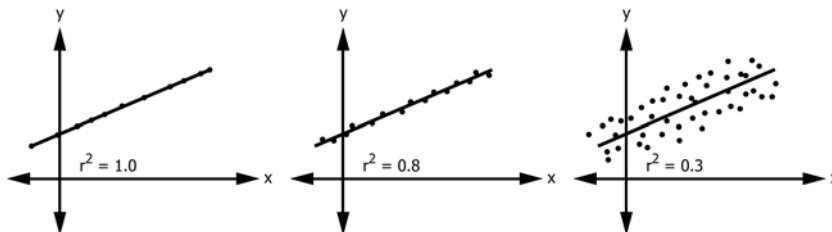
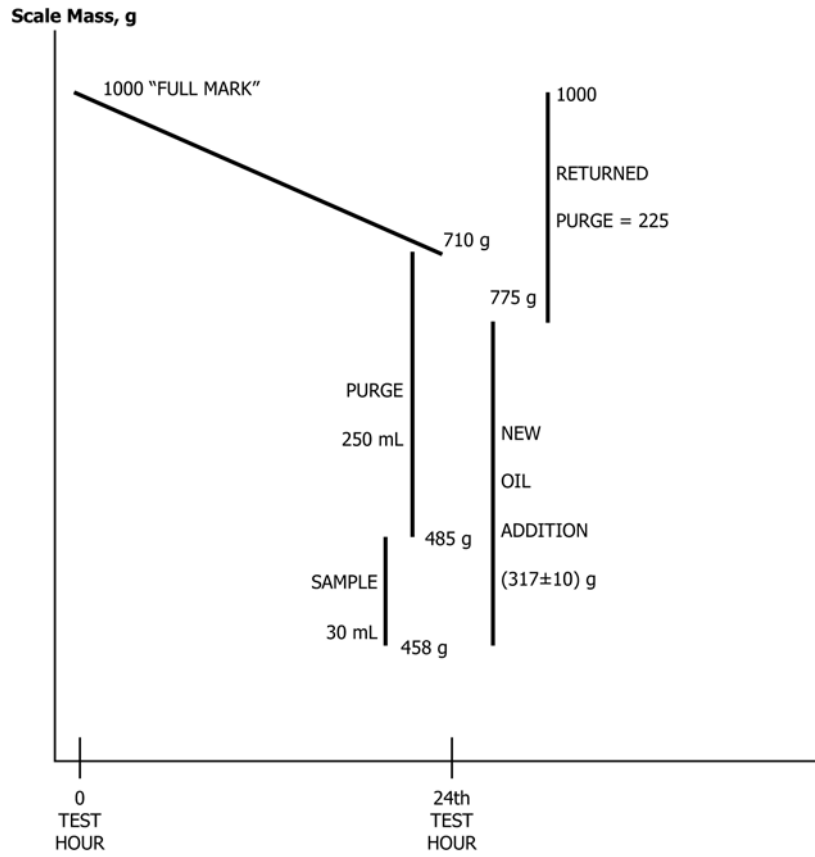
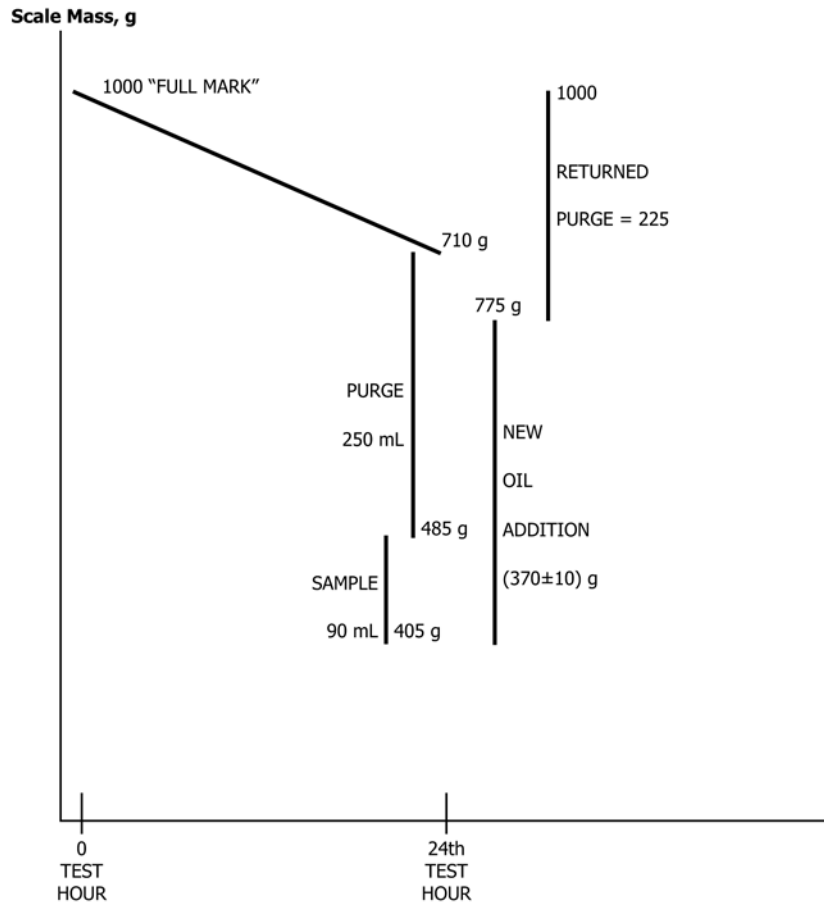

FIG. A6.6 Examples of the Goodness of Fit



NOTE 1—Taken at 48 h, 72 h, 120 h, 144 h, 168 h, 192 h, 216 h, 264 h, 312 h, and 336 h.

**FIG. A6.7 Example of Oil Addition Procedure with 30 mL Sample**



NOTE 1—Taken at NEW (0 h), 24 h, 96 h, 240 h, 288 h, and 360 h.

**FIG. A6.8 Example of Oil Addition Procedure with 90 mL Sample**

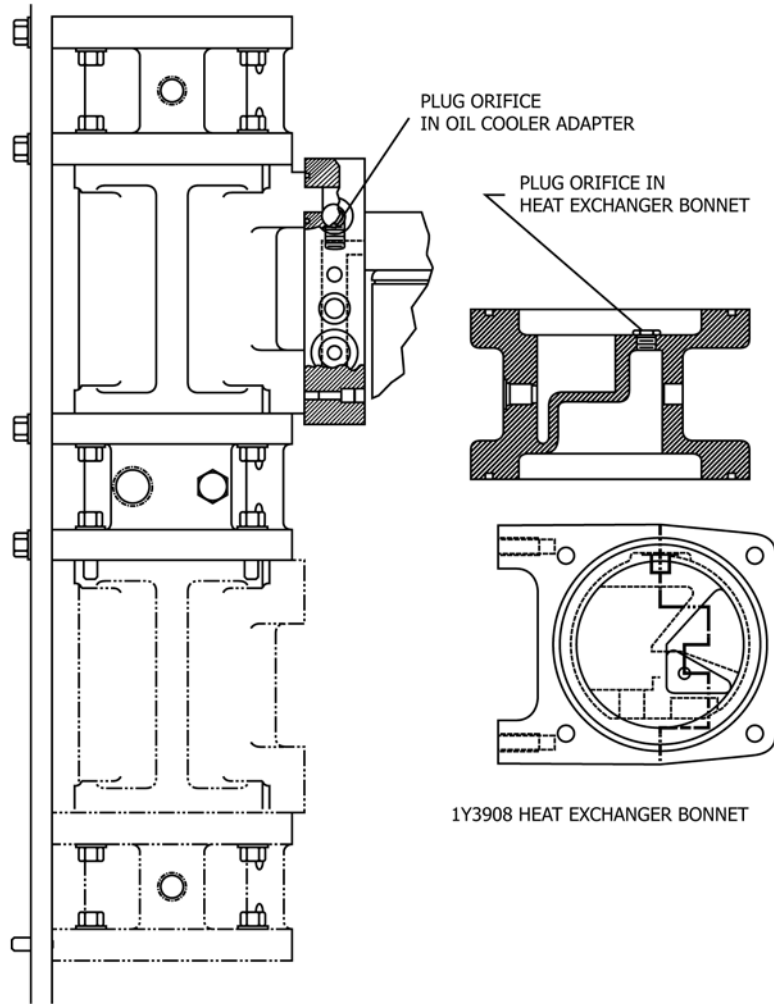

FIG. A6.9 Engine Oil Heating Hardware

### A7. EXHAUST AND INTAKE BARREL PIPING

A7.1 The exhaust and intake barrel piping are illustrated in Figs. A7.1 and A7.2.



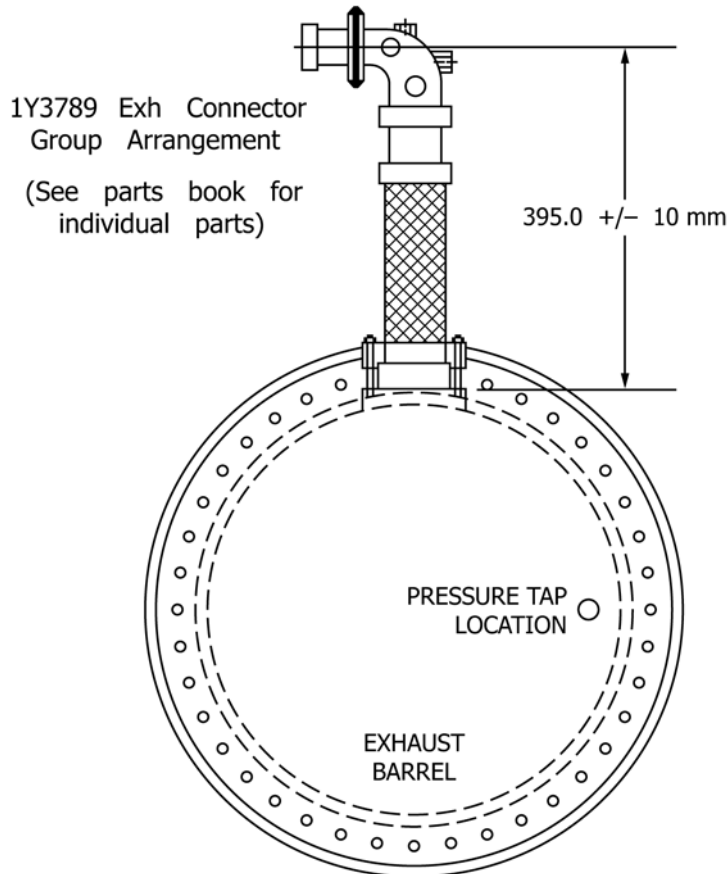
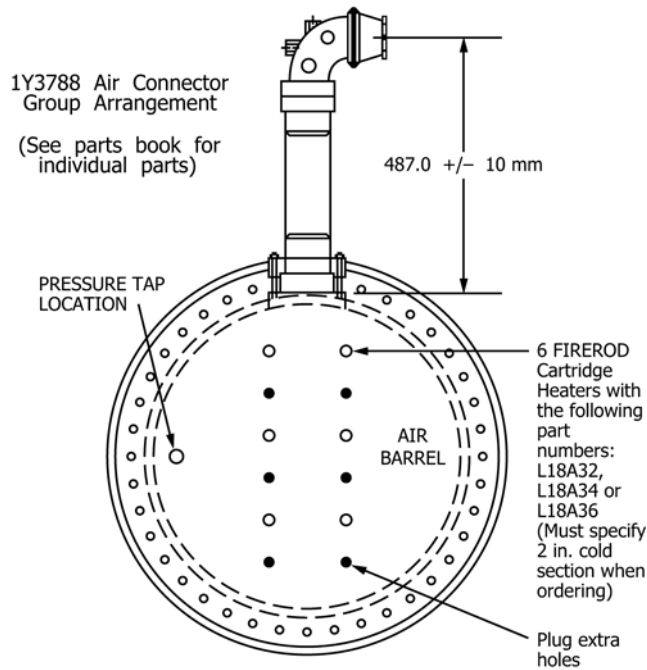

FIG. A7.1 1Y3978 Exhaust Barrel and Piping



NOTE 1—Dummy heater elements may be substituted for the FIREROD cartridge heaters, as long as they are the same dimension of 533 mm by a diameter of 15.9 mm. The 533 mm is from end-to-end. Length tolerance is 76 mm and the diameter tolerance is 0.40 mm.

NOTE 2—FIREROD cartridge heaters may be purchased from Southwest Heater and Controls, 12052 Forestgate Dr., Dallas, TX 75243.

FIG. A7.2 1Y3976 Intake Air Barrel and Piping

A8. HUMIDITY PROBE INSTALLATION

A8.1 Figs. A8.1 and A8.2 illustrate the humidity probe installation locations.

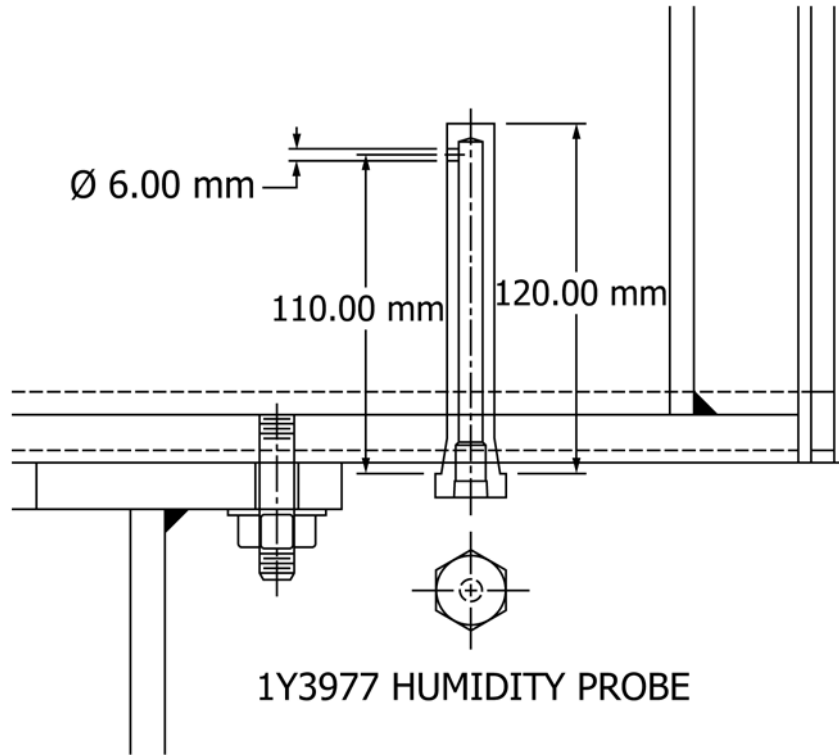

FIG. A8.1 Humidity Probe Installation Location

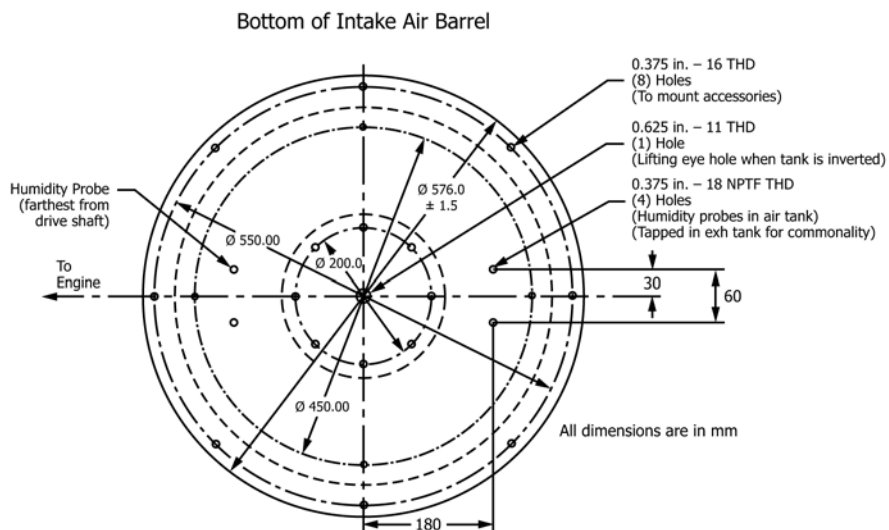

FIG. A8.2 Humidity Probe Installation Location—Barrel Bottom

**A9. RETURN GOODS AUTHORIZATION**

A9.1 Fig. A9.1 is a sample return goods authorization claim form.

Return Goods Authorization Number: \_\_\_\_\_.

Claim Date: \_\_\_\_\_.

Contact: Caterpillar Inc  
Engine System Tech Dev.  
P.O. Box 610  
Mossville, IL 61552  
Phone: 309-636-5247  
Fax: 309-675-1598  
Attn: R.A. Riviere

Part Number / Quantity: \_\_\_\_\_ / \_\_\_\_\_.

Part Name / Hrs On Part: \_\_\_\_\_ / \_\_\_\_\_.

Date Part Purchased: \_\_\_\_\_.

Engine Serial Number: \_\_\_\_\_.

**Test Lab**

Name: \_\_\_\_\_.

Address: \_\_\_\_\_.

Contact Person's Name: \_\_\_\_\_.

Phone Number: \_\_\_\_\_.

Fax Number: \_\_\_\_\_.

Name of Dealer That Sold Part: \_\_\_\_\_.

**INCLUDE DOCUMENTATION AND PHOTOS OF NONCONFORMING PART  
FIG. A9.1 Sample Return Goods Authorization Claim Form**

**A10. ENGINE ASSEMBLY INFORMATION**

A10.1 *1Y3700 Engine Mechanical Timing*—Remove the camshaft gear to replace cylinder head components after test and re-time as follows (see Fig. A10.6):

A10.1.1 Rotate the engine to position the piston at TDC.

NOTE A10.1—The TDC mark on the flywheel aligns with the timing

pointer. The 1Y3919 timing pin has a diameter of 6.28 mm and inserts in the crank gear key-way slot through the timing hole in the front housing near the oil pump flange.

A10.1.2 Pin the camshaft with a second 1Y3919 timing pin with a diameter of 6.28 mm.

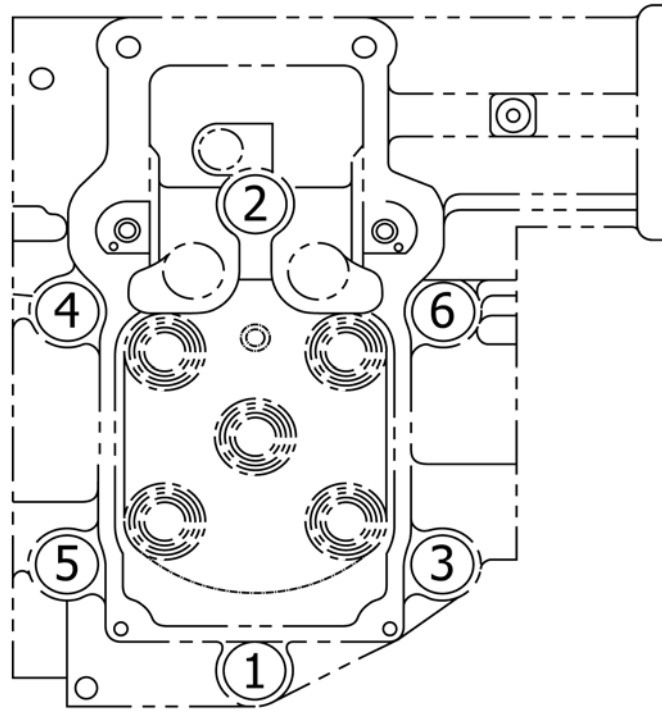

NOTE 1—

- (1) Lubricate stud threads and both washer faces with Mobil EF411 engine oil.
- (2) Tighten cylinder head nuts with hand torque wrench:

- (a) Tighten nuts 1 through 6 in numerical sequence to  $100 \text{ N}\cdot\text{m} \pm 15 \text{ N}\cdot\text{m}$ .
- (b) Tighten nuts 1 through 6 in numerical sequence to  $200 \text{ N}\cdot\text{m} \pm 15 \text{ N}\cdot\text{m}$ .
- (c) Tighten nuts 1 through 6 in numerical sequence to  $400 \text{ N}\cdot\text{m} \pm 15 \text{ N}\cdot\text{m}$ .

NOTE 2—Coat valve stems with Mobil EF411 engine oil immediately prior to installation.

**FIG. A10.1 Cylinder Head Tightening Procedure**

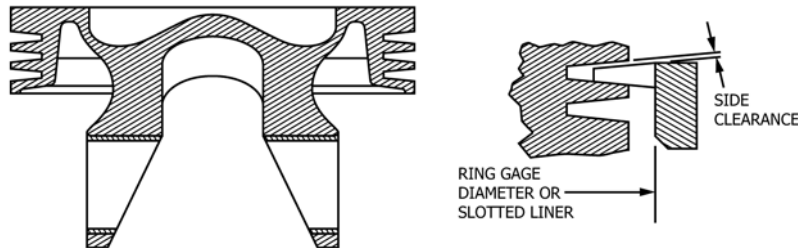

NOTE 1—Piston part nos: Skirt 1Y3659, Crown 1Y3400;  
Rings part nos: Top 1Y3802, Intermediate 1Y3803, Oil 1Y3804.

**FIG. A10.2 Piston and Ring Specifications**

A10.1.3 Mesh the camshaft gear with the adjustable idler gear and with the UP mark on the front face of the camshaft gear in the 12:00 o'clock position. Assemble the camshaft gear to the camshaft.

A10.1.4 Set lash between the adjustable idler gear and the camshaft gear and torque the six socket head bolts at the stub-shaft flange.

A10.1.5 Remove both timing pins with diameters of 6.28 mm.

**A10.2 1Y3700 Engine Mechanical Timing—General Information:**

NOTE A10.2—This is not part of the normal engine timing procedure.

A10.2.1 Follow this procedure only on new engine assembly or in the event that a new timing disk, or crankshaft, or flywheel, or front housing is assembled on an old engine.

A10.2.2 With the crankshaft connecting rod journal at top dead center (TDC), the tooth valley V mark on the crankshaft gear is  $35.38^\circ$  clockwise from the vertical and the key-way is  $68.48^\circ$  clockwise from vertical. With the crankshaft gear fixed, assembly of the cluster idler gear on its stub-shaft causes the cluster idler gear to rotate  $2.87^\circ$  clockwise, so that its dash marked tooth is  $145.73^\circ$  counterclockwise from vertical. The V and dash marks line up valley-to-tooth.

**Liner Bore Surface Finish**  
 0.4 – 0.8  $\mu\text{m}$  (Ra)

**Negative Liner Projection**  
 (Measure with O-rings removed from liner)  
 – Measure from jug top surface to bottom of liner seal surface with modified 8T0455 indicator  
 – Specification is 1.02 +/- 0.06 mm

**Unassembled Liner Bore I.D.**  
 137.185 +/- 0.025 mm

**Liner Assembled in Jug and Head Torqued**  
 – Liner bore out-of-round is 0.038 mm max. (difference of transverse and longitudinal dia. at each vertical height level)  
 – Liner bore taper is 0.050 mm max. (difference of all vertical height dia. in either the transverse or longitudinal direction)  
 – Minimum assembled liner bore dia. is 137.154 mm

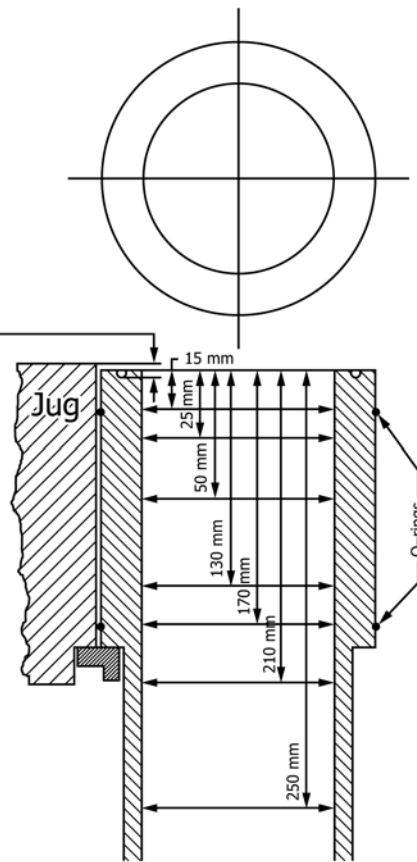

**FIG. A10.3 Cylinder Liner Measurements and Specifications**

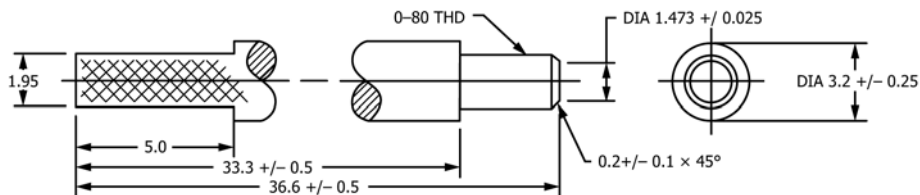

NOTE 1—Grind the tip to 1.95 mm ± 0.02 mm diameter for 5.0 mm ± 0.5 mm long from spherical end. All dimensions are in mm.

NOTE 2—Indicator measures liner recession from the jug deck surface to the bottom of the liner combustion seal groove. The tip of the 8T0455 indicator rod requires modifications as indicated.

**FIG. A10.4 Cylinder Liner Projection Measurement Indicator Modifications**

A10.2.3 Assembly of the adjustable idler gear with its UP mark at the top orients the three kidney-shaped openings in the gear web to allow access to the socket head bolts that attach the adjustable idler gear stub-shaft to the front housing plate.

A10.2.4 Assembly of the camshaft gear with its V mark and UP mark at the top and with the camshaft pinned to the cylinder head, by design, results with the 12.7 mm bolts on-center of the clearance holes in the camshaft gear, each having a diameter of 17 mm. Additive tolerances for all the involved parts can cause the bolts to be off-center in either direction. The purpose of the oversize holes is to ensure that the gears mesh at all off-nominal, but in tolerance dimensions of the parts.

A10.2.5 With the camshaft and the crankshaft pinned, the engine is necessarily at top dead center on the firing stroke. The

flywheel pointer is at 0° (TDC). The leading edge of a 3° timing notch on the camshaft gear is on the centerline of the cam sensor hole in the front housing. The leading edge of a 6° notch on the crankshaft timing disk is on the centerline of the crankshaft sensor hole in the front housing.

A10.2.6 With the flywheel pointer at 3° after top dead center, a 1Y3918 pin inserted in the crank timing sensor hole in the front housing shall also slide into a 6° wide notch of the crankshaft timing disk. This verifies that the leading edge of a notch on the timing disk is on the centerline of the crankshaft sensor which sets TDC for the electronic control module (ECM).

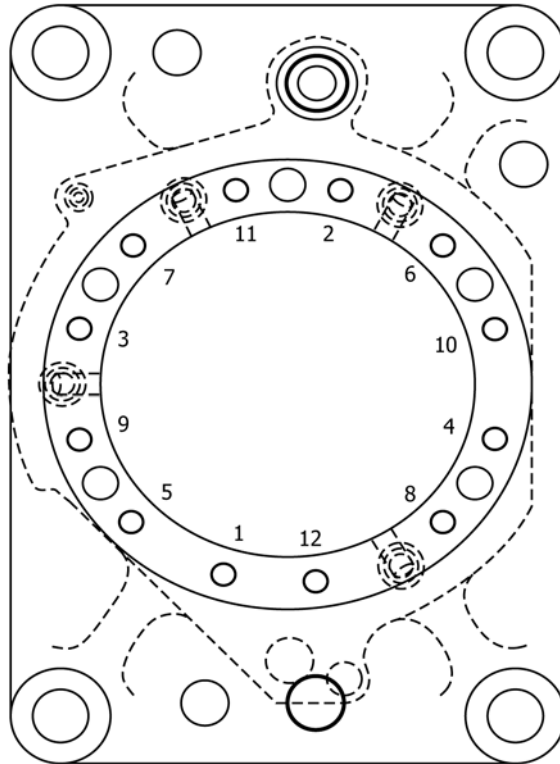

NOTE 1—Center the support ring I.D. to the cylinder liner with four feeler gages of equal thickness, hand tighten the stud nuts, but remove feeler gages before tightening stud nuts.

NOTE 2—Tighten the stud nuts in numerical order as shown with a sequence level of 15 N·m, 55 N·m, and 105 N·m  $\pm$  10 N·m.

NOTE 3—The cylinder liner support ring torque sequence may be used after the cylinder head torque sequence as an alternate method if the liner bore distortion is out of test specifications.

**FIG. A10.5 Cylinder Liner Support Ring Tightening Procedure**

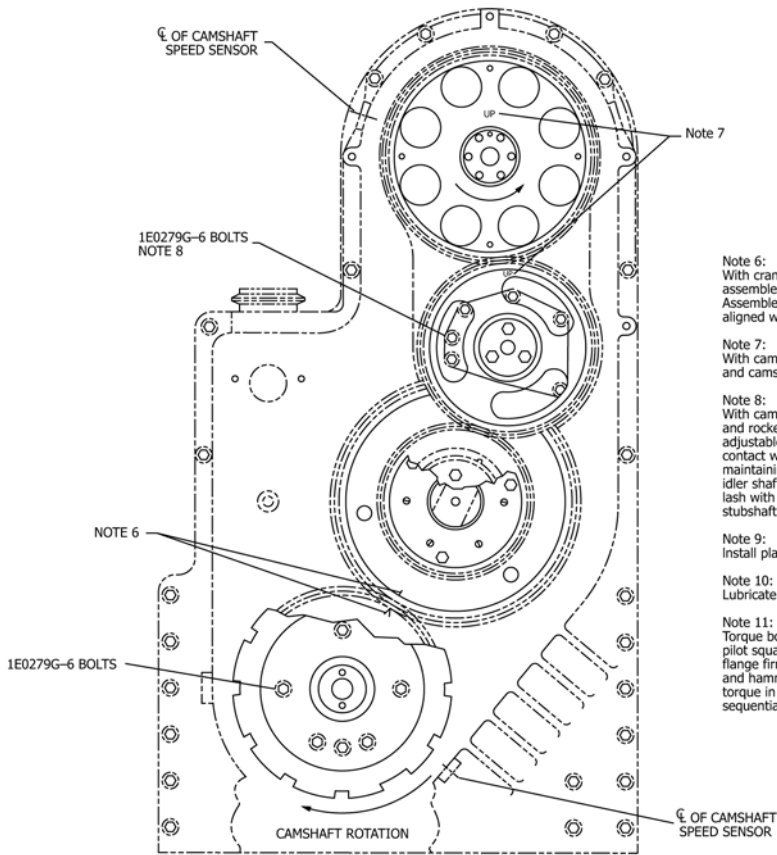

Note 6:  
With crankshaft connecting rod journal at TDC, assemble crankshaft gear over nose of crankshaft. Assemble cluster idler gear with DASH marked tooth aligned with V marked tooth of crankshaft gear.

Note 7:  
With camshaft pinned, assemble adjustable idler gear and camshaft gear with UP marks at the top.

Note 8:  
With camshaft pinned and camshaft gear bolts torqued and rocker arm shaft bolts backed out, rotate the adjustable idler gear on its shaft CCW to make tooth contact with the small cluster idler gear. While maintaining this tooth contact, slide the adjustable idler shaft with gear CCW to obtain  $0.216 \pm 0.114$  mm lash with the camshaft gear and tighten the six stubshaft bolts. Recheck lash value.

Note 9:  
Install plate with oil groove toward gear face

Note 10:  
Lubricate bearing with engine oil

Note 11:  
Torque bolts evenly in a cross-pattern to draw shaft pilot squarely into bore in plate. Seat stubshaft flange firmly against front plate with a center driver and hammer. Torque bolts to the final assembly torque in a cross-pattern. Re-torque bolts in a sequential pattern.

FIG. A10.6 1Y3700 Engine Timing



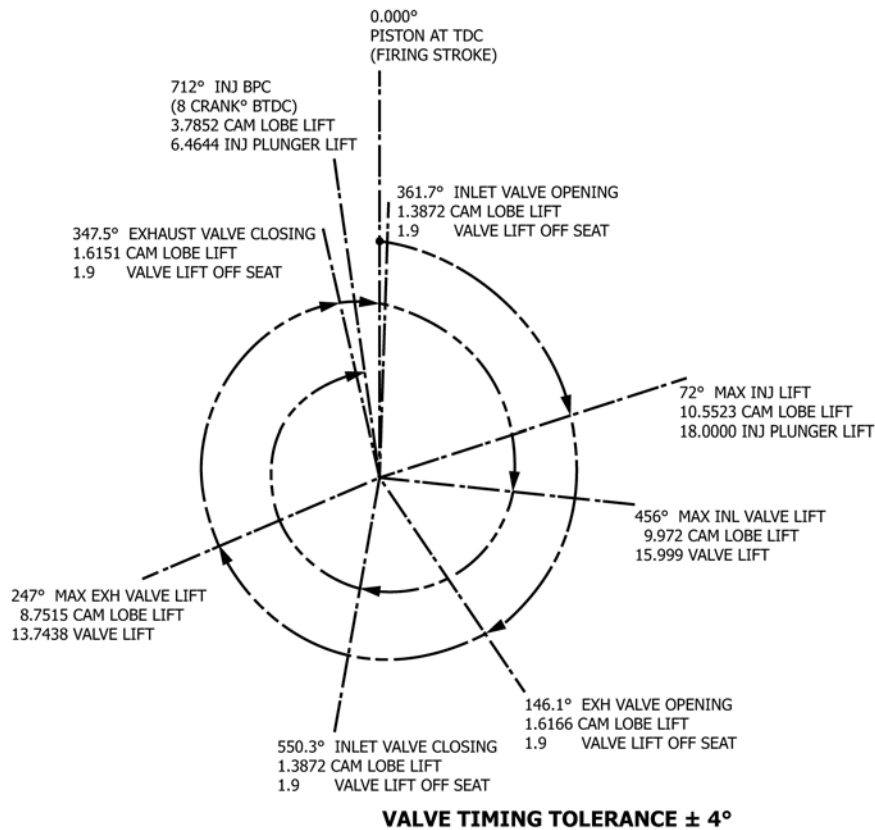

NOTE 1—

- (a) Timing events in crankshaft degrees (reference only).
- (b) As viewed from front.
- (c) intake valve clearance set cold at 0.38.
- (d) intake valve clearance set cold at 0.76.
- (e) 1998 Scote engine.

**FIG. A10.7 Timing Events in Crankshaft Degrees (for reference purpose only)**

**TABLE A10.1 Piston and Ring Specifications**

	Top Ring <sup>A</sup>	Intermediate Ring <sup>A</sup>	Oil Control Ring <sup>A</sup>
Width of groove in piston for piston ring (new)			3.21 mm ± 0.01 mm
Thickness of piston ring (new)			3.137 mm ± 0.006 mm
Side clearance between groove and piston ring (new)	0.080 mm, min	0.140 mm to 0.214 mm	0.057 mm to 0.089 mm
End gap clearance between end of ring (new) installed in a gage with a diameter of 137.160 mm	0.585 mm to 0.737 mm	1.004 mm to 1.156 mm	0.382 mm to 0.636 mm

<sup>A</sup> This engine uses keystone style piston rings and grooves in the piston. The piston ring lands are also elliptically ground; therefore, measure ring side clearance as follows:

- (a) Assemble piston ring on the piston with UP side toward the top of the piston.
- (b) Install piston and ring in a ring gage with a diameter of 137.60 mm or modified slotted liner (see Appendix X1).
- (c) Push piston and ring until ring to be measured is at the top of the gage. Keep the piston in the center of the gage.
- (d) Measure the side clearance with a feeler gage at both major (90° from the centerline of the pin bore) and minor diameters. Each measurement should be within specification shown.
- (e) Install the oil control ring with gap in the spring 180° away from the gap in the ring.

**TABLE A10.2 Engine Assembly Measurements, mm**

Items to be checked	Specifications			Actual
	min	mean	max	
Crankshaft end play	0.11	0.34	0.57	
Camshaft end play	0.175	0.25	0.325	
Main bearing clearance (no.1) (front)	0.089	0.138	0.187	
Main bearing clearance (no.2)	0.089	0.138	0.187	
Main bearing clearance (no.3)	0.089	0.138	0.187	
Main bearing clearance (no.4)	0.089	0.138	0.187	
Nozzle tip projection	1	1.3	1.6	
Cam gear backlash	0.102	0.216	0.33	
Piston to head clearance	1.55	1.62	1.69	
Intake valve (1) Recess (closest to manifold)	2.2	2.5	2.8	
Intake valve (2) Recess	2.2	2.5	2.8	
Exhaust valve (1) Recess (closest to manifold)	1.2	1.5	1.8	
Exhaust valve (2) Recess	1.2	1.5	1.8	
Initial intake valve lash (cold)		0.38		
Initial exhaust valve lash (cold)		0.76		
Initial injector setting		78 <sup>A</sup>		A
After test intake valve lash (cold)	0.3	0.38	0.46	
After test exhaust valve lash (cold)	0.68	0.76	0.84	
After test injector setting	77.8 <sup>A</sup>	78 <sup>A</sup>	78.2 <sup>A</sup>	A
Flywheel adapter runout (bore TIR)			0.15	
Flywheel adapter runout (face TIR)(at R95)			0.15	
Timing sensor location in front housing	2° ATDC	3° ATDC	4° ATDC	
Liner negative projection	1.12	1.17	1.22	
Liner ID taper			0.051	
Liner ID out of roundness			0.038	
Liner ID smallest anywhere			137.154	
Align pointer with TDC mark on flywheel.				
Verify top of liner is below jug surface.				
Flow cooling jet to verify aim.				
Injector and valve max lifts				
Injector plunger lift at 72° crank	17.3	18.0 mm	18.7	
Exhaust valve lift at 247° crank	13.0	13.7 mm	14.4	
Intake valve lift at 456° crank	15.3	16.0 mm	16.7	

<sup>A</sup> Go/No-Go gage

## A11. FLUSHING INSTRUCTIONS AND APPARATUS

A11.1 [Table A11.1](#) is the flushing instruction sheet and [Figs. A11.1-A11.3](#) illustrate the flushing apparatus.

TABLE A11.1 Flushing Instruction Sheet

Step	Procedure	Flushing Fluid	Relief Valve <sup>A</sup>
1	Drain used oil from sump, cooler, oil scale and remove oil filter Install 1Y3916 plug in front plate (in place of fuel cam/cylinder head) Install 1Y3979 cover on top of block Install 1Y3980 piston jet aim fixture on top of 1Y3979 cover		
2	Connect flush cart outlet to filter flush adapter 1Y3935 and 5 spray nozzles Connect flush cart pump inlet to solvent tank Install new oil filter on the oil flush cart Open engine sump drain. Then pump solvent into engine to flush used oil		open
3	Connect flush cart pump inlet to engine oil sump Close engine sump drain Circulate fluid with flush cart and oil scale pumps turned on	7.6 L Stoddard solvent no recirculation Cleaning mixture of 1.9 L Dispersant Engine Cleaner 5.7 L Stoddard Solvent	closed
4	Drain mixture from sump, cooler, oil scale, flush cart and filters		closed 5 min. open 5 min.
5	Circulate fluid with flush cart and oil scale pumps turned on	7.6 L Stoddard Solvent	open 5 min. closed 5 min.
6	Drain fluid from sump, cooler, oil scale, flush cart and filters		open
7	Repeat steps 5 and 6 two times or as needed until solvent remains clean		open 5 min. closed 5 min.
8	Circulate EF-411 to flush Stoddard solvent	5.6 L EF-411	open
9	Drain oil from sump, cooler, oil scale, flush cart and filters		open 5 min.
10	Circulate EF-411 at 415 kPa manifold pressure and align piston jets	5.6 L EF-411	open
11	Drain oil from sump, cooler and oil scale. Rebuild engine for test		open
12	After engine is rebuilt, motor engine at a minimum of 200 r/min	5.6 L EF-411	Reconnect for normal operation
13	Drain oil from sump, cooler and oil scale		open

<sup>A</sup> Supply 50 kPa air pressure to open the Johnson Controls oil relief valve.

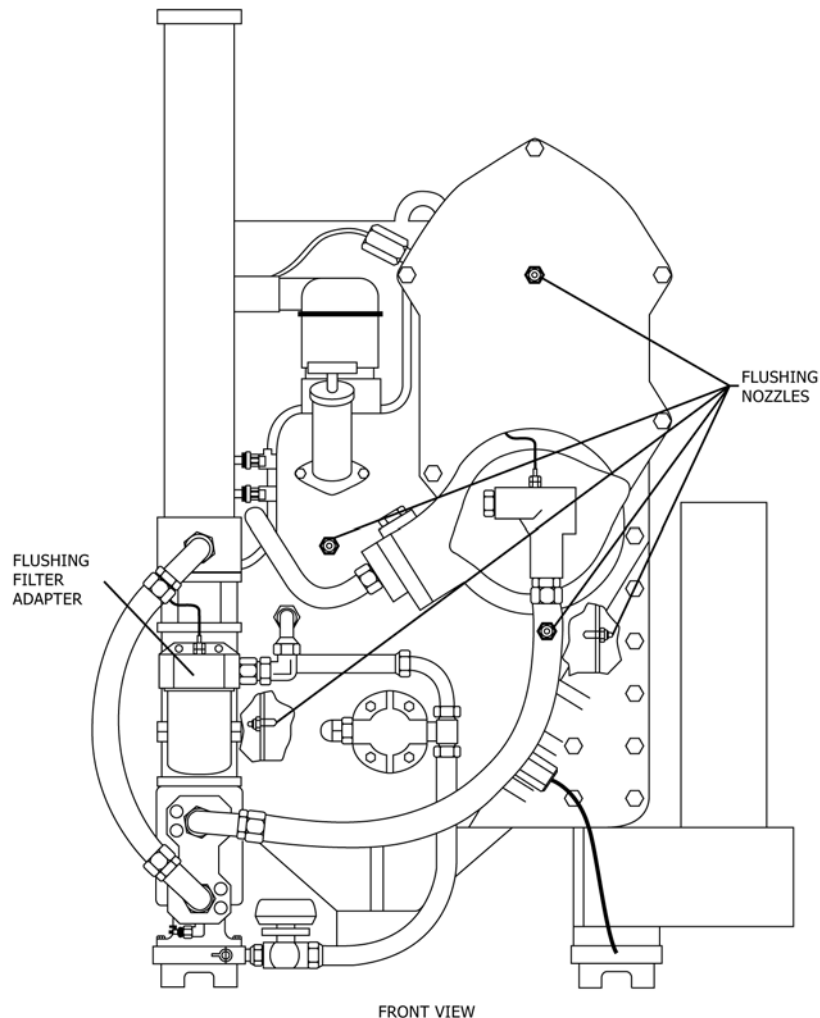

FIG. A11.1 Flushing Nozzle Locations

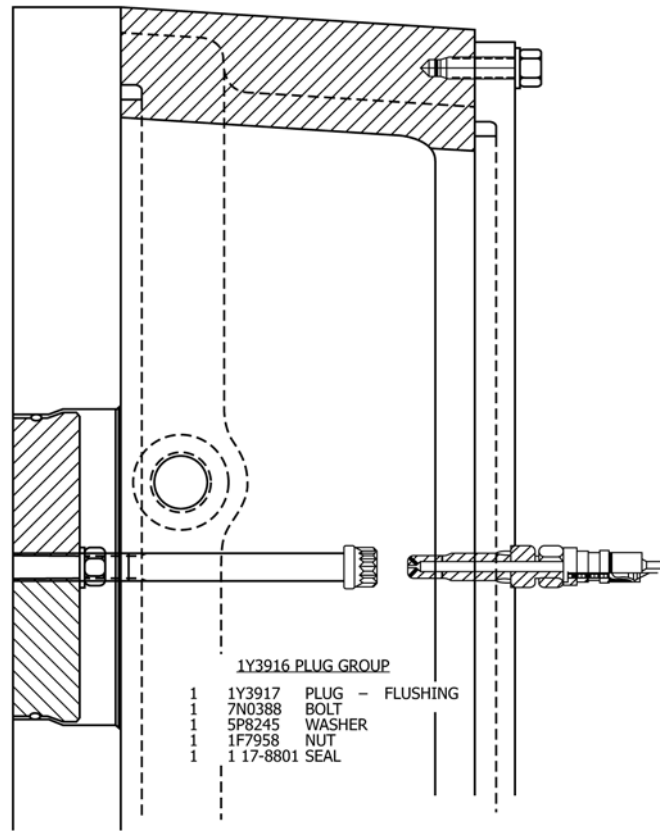
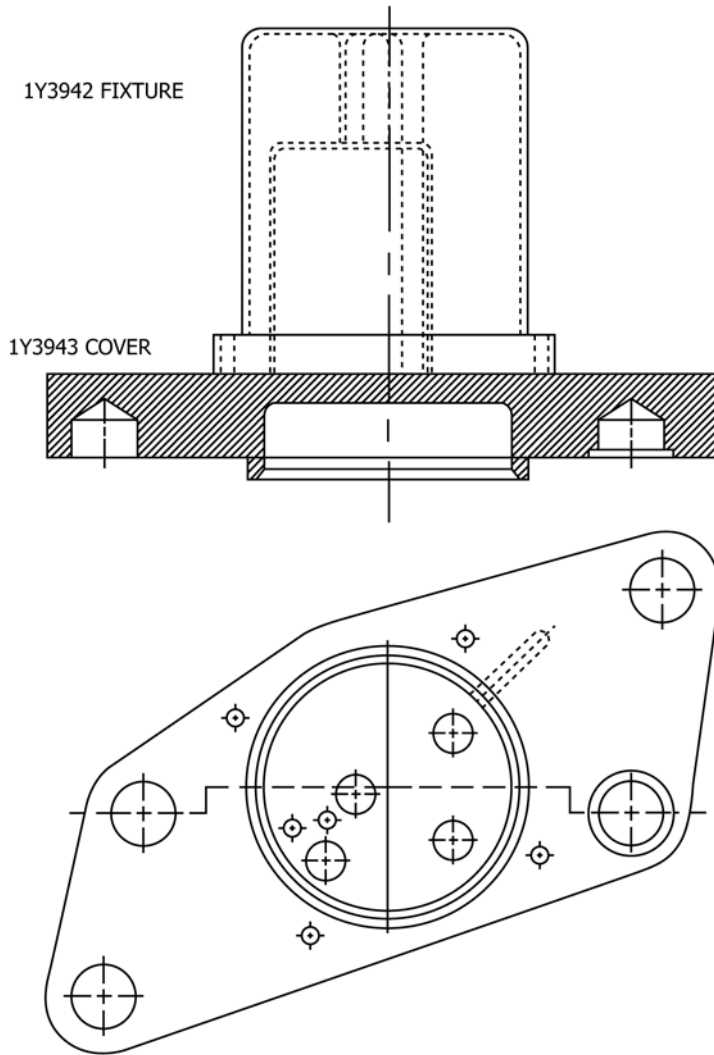

FIG. A11.2 Flushing Plug



**A12. WARM-UP, COOL-DOWN, AND TESTING CONDITIONS**

A12.1 See [Table A12.1](#).

**TABLE A12.1 Warm-up, Cool-down, and Testing Conditions**

NOTE 1—

(a) Engine controlled to torque specification for Steps 2, 3, 4 and 5 min of Step 5.

(b) Engine controlled to fuel rate specification for last 55 min of Step 5.

(c) Air pressure at coolant tower controlled to 35 kPa.

(d) Oil pressure operating specifications apply only to 15W-40 oils. Attempt to maintain these limits for all oils. When oils other than 15W-40 oils fall outside these limits, explain these deviations from the limits in the comments section of the test report.

NOTE 2—Ramp Up Conditions Between Warm-up Steps:

(a) Torque (N·m/min); at 5 min (beginning at Step 2)— 20 N·m/min.

(b) Speed (r/min); at 10 min (beginning at Step 3)— 100 r/min/min.

(c) Inlet air pressure (kPa); at 10 min (beginning at Step 3)— 12 kPa/min.

(d) Exhaust air pressure (kPa); at 10 min (beginning at Step 3)— 12 kPa/min.

(e) Inlet air temperature (°C); at 10 min (at start of test)— 5 °C/min.

Parameter	Units	Tol	Test Specifications				
			Step 1 5 min	Step 2 5 min	Step 3 5 min	Step 4 10 min	Step 5 60 min
Speed	r/min	±3	1000	1000	1400	1800	1800
Power	kW		idle	10	26	41	~55
Torque	N·m	(a) ±5		100	176	219	~285
Fuel rate	g/min	(b) ±1		48	95	148	185
Fuel timing	BTC		13	13	13	13	13
Humidity	g/kg	±1.7					17.8
<b>Temperatures °C</b>							
Fuel into head		±3	~31	~32	~33	~36	42
Coolant into jug			~41	~51	~82	~86	86
Coolant from head		±3	42	52	83	90	90
Oil to cooler							~128
Oil manifold (d)		±3					130
External heating oil			165 max	165 max	165 max	165 max	165 max
Intake air manifold		±3			60	60	60
Exhaust manifold			~120	~275	~340	~370	~480
<b>Pressures kPa</b>							
Fuel from head		±20	275	275	275	275	275
Coolant into jug		(c)	~44	~44	~70	~81	~81
Oil manifold		±20	415	415	415	415	415
Intake air barrel (abs)		±1	120	120	157	225	272
Exhaust barrel (abs)		±1		104	146	217	265
Crankcase						~.05	~.10
<b>Flows</b>							
Coolant	L/min	±2	~34	~34	~55	75	75
Blowby	L/min					~35	~35
Air	kg/h						~315

### A13. PISTON AND LINER RATING MODIFICATIONS

A13.1 The 1P piston deposits are accessed using the Modified Diesel Piston Rating Method described in ASTM Deposit Rating Manual 20. Three levels of carbon (heavy, medium, and light) are rated for grooves one and three. Only two levels of carbon (heavy and light) are rated for the second groove and all lands, and only one level of carbon (light) is rated for the cooling gallery and under-crown. The carbon deposit factors are 1.00 for heavy, 0.5 for medium, and 0.25 for light carbon. The varnish merit values range from 1.0 to 10 using the ASTM Rust/Varnish Rating Scale where 10 is clean and 1.0 is maximum intensity. The merit varnish values are converted to demerit values resulting in deposit factors that range from 0 for clean to 9.0 for maximum intensity. The merit varnish values are converted to demerit values using [Eq A13.1](#):

$$\text{Demerit Varnish Zonal Rating} = \text{Area \%} \times (10 - \text{Merit Rating}) \tag{A13.1}$$

A13.1.1 *Example*— $15 \% \times (10.0 - 8.5) = 0.15 \times 1.5 = 0.22$  demerits using rounding guidelines presented in [Practice E29](#).

A13.1.2 [Fig. A13.1](#) shows the deposit rating areas for the under-crown and cooling gallery of the piston crown.

A13.2 The rating location factors were chosen to yield separation between low and high calibration oils. All required rating equipment, such as the rating booth and particular lamp used, are described in ASTM Deposit Rating Manual 20.

A13.3 Use the following procedure for calculating this test method's piston deposit ratings:

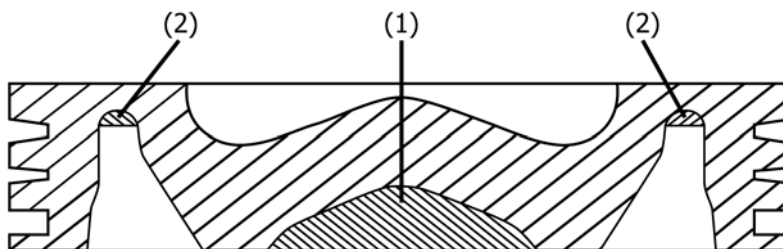

NOTE 1—Area 1—Under-crown: All surfaces of the under-crown including transition radius, but not the vertical sides of the pin bore struts. Area 2—Cooling gallery: Only the upper radius area.

FIG. A13.1 Under-crown and Cooling Gallery Rating Areas

TABLE A13.1 Grouped Varnish Rating Factors

Rater-Assigned Varnish Merit Value	Restricted Factor
1.0–4.0	7.5
4.1–7.0	4.5
7.1–9.9	1.5

A13.3.1 Rate the piston as is normally done according to the Modified Diesel Piston Rating Method described in ASTM Deposit Rating Manual 20.

A13.3.2 For groove three, land three, land four, the cooling gallery and under-crown, replace the rater-assigned varnish merit values with the restricted factors listed in Table A13.1.

A13.3.3 Calculate a demerit value for each area.

A13.3.4 Round each demerit to the nearest 0.01 demerits according to Practice E29.

A13.3.5 Add the demerits to get the individual unweighted demerit value for each piston location.

A13.3.6 Multiply the unweighted demerit value by its location factor to get the individual weighted demerit rating for each piston location.

A13.3.7 Round each individual weighted demerit rating to the nearest 0.01 demerits.

A13.3.8 Add all individual weighted demerit ratings to get WDP.

A13.3.9 Round WDP to the nearest 0.1 demerits.

A13.3.10 Top groove carbon (TGC) equals the total carbon demerits for groove one.

A13.3.11 Top land carbon (TLC) equals the total carbon demerits for land one.

A13.4 *Liner Rating Procedure*—Liner rating should follow the sequence outlined herein. If deposits above ring travel are to be evaluated this should be done immediately upon completion of the test or disassembly.

A13.4.1 *Liner Preparation:*

A13.4.1.1 *Marking*—Thrust and anti-thrust sides are marked T & AT along with appropriate test identification (run number, and so forth). See Fig. A13.2.

A13.4.1.2 *Cutting*—Liners are cut along the front and rear, leaving the thrust and anti-thrust halves.

A13.4.1.3 *Surface Preparation*—Caution should be observed in the handling of the liners due to the sharpness of the cut edges. Wipe both halves of the liner using Stoddard solvent on a dampened soft rag followed by a clean soft dry rag.

A13.4.2 *Definition of Terms*—A clear plastic segmented overlay (see Fig. X1.6) is recommended as a useful rating aid in estimating the percentage of the area covered.

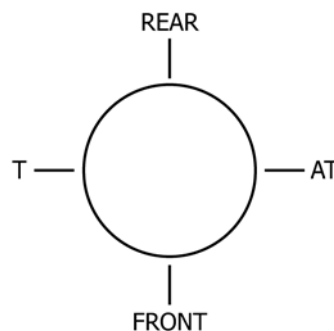

FIG. A13.2 Liner Thrust and Anti-Thrust Locations

A13.4.2.1 *Bore Polishing*—Those areas of surface which are instantly recognizable as mirror finish regardless of random crosshatch honing marks.

A13.4.2.2 *Scuffing*—Localized adhesive wear distinguished by concentrated marks in the direction of motion, observed as a matte finish which is caused by a momentary welding and tearing of metal.

NOTE A13.1—Bore polishing and scuffing should be differentiated between and reported separately.

A13.4.2.3 *Scratching*—Random singular lines in the direction of motion generally a result of debris or installation of components. These need not be quantified, but should be noted in the appropriate remarks section.

A13.4.3 *Liner Rating:*

A13.4.3.1 *Rating Environment*—Rate liners in the ASTM rating booth with the same light as specified to rate pistons or a two-bulb fluorescent desk lamp.

A13.4.3.2 *Bore Polishing*—The overlay is inserted in the liner half and the 10 % to 15 % segments with 1 % indicators used as a guide in estimating the amount of polishing. Record the percent polish for each segment and then summarize those ten areas for each half. Tracing paper or equivalent may be used for a permanent record of the liner polishing.

(1) *Area Rated*—The area to be rated is generally defined as the area swept by the rings that is the distance from the top



of the first ring at TDC to the bottom of the ring at BDC. On many occasions, it is required that the area above top ring travel be rated.

A13.4.3.3 *Liner Scuffing Rating*—Liner scuffing can be rated in a similar manner as bore polishing.

A13.4.3.4 *Above Top Ring Travel Conditions*—Area percentages may be determined in the liner by use of the 20-segmented template. Carbon deposits can be rated in two levels. Other conditions such as polishing, scratching/scuffing can be reported in area covered, if required.

#### **A14. ADDITIONAL REPORT FORMS**

A14.1 **Figs. A14.1 and A14.2** are sample report forms.

Product: \_\_\_\_\_  
 Product No.: \_\_\_\_\_

 Batch No.: \_\_\_\_\_  
 TMC No.: \_\_\_\_\_  
 TMO No.: \_\_\_\_\_  
 Tank No.: \_\_\_\_\_  
 Analysis Date: \_\_\_\_\_  
 Shipment Date: \_\_\_\_\_

TEST	METHOD	UNITS	SPECIFICATIONS			RESULTS, °C
			MIN	TARGET	MAX	
Distillation — IBF	D86	°C	177			
10 %		°C	210			
50 %		°C	249			
90 %		°C	299			
Distillation — EP		°C	327			
Recovery		vol %		REPORT		
Residue		vol %		REPORT		
Loss		vol %		REPORT		
Gravity	D4052	°API	32.0		36.0	
Pour Point	D97	°C			-17	
Cloud Point	D2500	°C			-12	
Flash Point	D93	°C	54			
Viscosity @ 40 °C	D445	mm <sup>2</sup> /s	2		3.2	
Mercaptan Sulfur	D3227	mass %		REPORT		
Sulfur	D2622	mass %	0.030		0.050	
Composition, Aromatics	D1319	vol %	28.0			
Composition, Olefins	D1319	vol %		REPORT		
Composition, Saturates	D1319	vol %		REPORT		
Basic sediment & water	D2709	vol %				
Ramsbottom Carbon, 10% residue	D524	mass %				
Ash content	D482	mass %				
Total Acid Number	D664	mg KOH/s		REPORT		
Strong Acid Number	D664	mg KOH/s		REPORT		
Accelerated Stability	D2274	mg/100 mL		REPORT		
Copper Corrosion	D130					
Cetane Number	D613					
Aliphatic paraffins	D2425	mass %		REPORT		
Monocycloparaffins	D2425	mass %		REPORT		
Dicycloparaffins	D2425	mass %		REPORT		
Tricycloparaffins	D2425	mass %		REPORT		
Alkylbenzenes	D2425	mass %		REPORT		
Indanes/Tetralins	D2425	mass %		REPORT		
Indenes	D2425	mass %		REPORT		
Napthalene	D2425	mass %		REPORT		
Napthalenes	D2425	mass %		REPORT		
Acenaphthenes	D2425	mass %		REPORT		
Acenaphthylenes	D2425	mass %		REPORT		
Tricylic aromatics	D2425	mass %		REPORT		

Approved by: \_\_\_\_\_

Analyst: \_\_\_\_\_

NOTE 1—Include a copy of Suppliers Fuel Sheet in the Test Report.

**FIG. A14.1 Fuel Batch Analysis Example**

Fax To:  
Company:  
Fax Number:

\*\*\*\* ASTM Test Monitoring Center \*\*\*\*  
\*\*\* 1P Control Charts Analysis \*\*\*

Start =		Lab =		CMIR =	
EOT date =		Stand =		IND =	
EOT time =		Run =			
LTMS date =		Reported =		Analysis Compiled:	
LTMS time =					

Parameter	Reported Value	Transformed Value	Targets Effective Mean	s	Note:	When two Limits given, the upper is the Warning Limit and the lower is the Action Limit.
-----	-----	-----	-----	---		

WDP						
TGC						
TLC					Keys:	A = Action alarm
AOC						W = Warning alarm
EOTOC						

**Stand Analysis**

	EWMA						SHEWHART										
		Severity				Precision					Severity				Precision		
	N	Z(i)	Limit	AI	Q(i)	Limit	AI	Y(i)	Limit	AI	R(i)	Limit	AI				
	---	-----	-----	-----	-----	-----	-----	-----	-----	-----	-----	-----	-----				

WDP													
TGC													
TLC													
AOC													
EOTOC													

**Laboratory Analysis**

		EWMA						SHEWHART										
			Severity				Precision					Severity				Precision		
	N	Z(i)	Limit	AI	Q(i)	Limit	AI	Y(i)	Limit	AI	R(i)	Limit	AI					
	---	-----	-----	-----	-----	-----	-----	-----	-----	-----	-----	-----	-----					

WDP													
TGC													
TLC													
AOC													
EOTOC													

\*\*\*\* Laboratory Level Severity Adjustments \*\*\*\*

WDP SA =	TGC SA =	TLC SA =
AOC SA =		EOTOC SA =

STAND is Calibrated: YES NO (Circle Required)

Calibration Expiration Date: \_\_\_\_\_

A TMC Validity Code: \_\_\_\_\_ AC = Acceptable Calibration.  
OC = Oper. Valid, Failed Acceptance Criteria.

\_\_\_\_ STAND PULLED FROM LTMS SYSTEM (Check required) Reviewer Initials: \_\_\_\_\_

A Based on review of call-in report of operational data and control chart analysis shown above.

**FIG. A14.2 Example of Fax Copy of TMC Control Chart Analysis for Calibration Tests**

## A15. REPORT FORMS

A15.1 Download report forms and data dictionary from the ASTM Test Monitoring Center (TMC) Web Page at: <http://www.astmtmc.cmu.edu/>. TMC can also provide hardcopies on request.

Report Form Table of Contents	
1. Final Report Cover Sheet	Cover
2. Test Report Summary	Form 1
3. Operational Summary	Form 2
4. Assembly Measurement and Parts Record	Form 3
5. Piston Rating Summary	Form 4
6. Piston Rating Worksheet	Form 4a
7. Supplemental Piston Deposits (Groove Sides and Rings)	Form 5
8. Referee Rating	Form 5a
9. Oil Analysis	Form 6

Report Form Table of Contents	
10. Downtime Summary	Form 7
11. Ring Measurements	Form 8
12. Liner Measurements	Form 9
13. Characteristics of the Data Acquisition System	Form 10
14. Engine Operational Data Plots	Form 11
15. Torque and Exhaust Temperature History	Form 12
16. Oil Consumption Plot	Form 13
17. Piston, Ring, and Liner Photographs	Form 14
18. Severity Adjustment History	Form 15
19. Fuel Batch Analysis	Form 16
20. TMC Control Chart Analysis	Form 17

NOTE A15.1—If the test will be submitted to the registration organization as a candidate oil, then use the same forms used for reporting reference test results and add the ACC Conformance Statement, Form 18.

## APPENDIXES

### (Nonmandatory Information)

#### X1. VARIOUS EXAMPLES FOR REFERENCE PURPOSES

X1.1 See [Figs. X1.1-X1.8](#).

C A R B O N	GROOVE 1			GROOVE 2			GROOVE 3			COOLING GALLERY			UNDER CROWN			
	A%	FCT	DEM	A%	FCT	DEM	A%	FCT	DEM	A%	FCT	DEM	A%	FCT	DEM	
	5	1.00	5.00	5	1.00	5.00	5	1.00	5.00							
	5	0.50	2.50				5	0.50	2.50							
5	0.25	1.25	5	0.25	1.25	5	0.25	1.25	5	0.25	1.25	5	0.25	1.25		
	SUBTOTAL 8.75			SUBTOTAL 6.25			SUBTOTAL 8.75			SUBTOTAL 1.25			SUBTOTAL 1.25			
V A R N I S H	9	8.5	0.76	9	8.5	0.76	11	8.5	0.82	7	7.5	0.52	7	7.5	0.52	
	7	7.5	0.52	7	7.5	0.52	7	7.5	0.52	9	4.5	0.40	9	4.5	0.40	
	9	6.5	0.58	9	6.5	0.58	3	6.5	0.22	7	1.5	0.10	7	1.5	0.10	
	7	5.5	0.38	7	5.5	0.38	13	5.5	0.58							
	9	4.5	0.40	9	4.5	0.40	9	4.5	0.40							
	7	3.5	0.24	7	3.5	0.24	5	3.5	0.22							
	9	2.5	0.22	9	2.5	0.22	11	2.5	0.16							
	7	1.5	0.10	7	1.5	0.10	7	1.5	0.10							
	9	0.5	0.04	9	0.5	0.04	3	0.5	0.04							
		SUBTOTAL 3.24			SUBTOTAL 3.24			SUBTOTAL 3.06			SUBTOTAL 1.02			SUBTOTAL 1.02		
		TOTAL 11.99			TOTAL 9.49			TOTAL 11.81			TOTAL 2.27		TOTAL 2.27			
	LOC FCT 2			LOC FCT 3			LOC FCT 20			LOC FCT 0.50		LOC FCT 1				
	WTD 23.98			WTD 28.47			WTD 236.20			WTD 1.14		WTD 2.27				

C A R B O N	LAND 1			LAND 2			LAND 3			LAND 4			
	A%	FCT	DEM	A%	FCT	DEM	A%	FCT	DEM	A%	FCT	DEM	
	5	1.00	5.00	5	1.00	5.00	5	1.00	5.00	5	1.00	5.00	
	5	0.25	1.25	5	0.25	1.25	5	0.25	1.25	5	0.25	1.25	
	SUBTOTAL 6.25			SUBTOTAL 6.25			SUBTOTAL 6.25			SUBTOTAL 6.25			
V A R N I S H	9	8.5	0.76	9	8.5	0.76	11	8.5	0.82	11	8.5	0.82	
	7	7.5	0.52	7	7.5	0.52	7	7.5	0.52	7	7.5	0.52	
	9	6.5	0.58	9	6.5	0.58	3	6.5	0.22	3	6.5	0.22	
	7	5.5	0.38	7	5.5	0.38	13	5.5	0.58	13	5.5	0.58	
	9	4.5	0.40	9	4.5	0.40	9	4.5	0.40	9	4.5	0.40	
	7	3.5	0.24	7	3.5	0.24	5	3.5	0.22	5	3.5	0.22	
	9	2.5	0.22	9	2.5	0.22	11	2.5	0.16	11	2.5	0.16	
	7	1.5	0.10	7	1.5	0.10	7	1.5	0.10	7	1.5	0.10	
	9	0.5	0.04	9	0.5	0.04	3	0.5	0.04	3	0.5	0.04	
		SUBTOTAL 3.24			SUBTOTAL 3.24			SUBTOTAL 3.06			SUBTOTAL 3.06		
		TOTAL 9.49			TOTAL 9.49			TOTAL 9.31			TOTAL 9.31		
	LOC FCT 1			LOC FCT 3			LOC FCT 20			LOC FCT 60			
	WTD 9.49			WTD 28.47			WTD 186.20			WTD 558.60			

WDP 1074.8  
TGC 8.75  
TLC 6.25

PISTON NO. 1	RING STUCK	SCUFFED AREA %	TLFC
TOP RING			
INT. RING			
OIL RING			
PISTON			
CYLINDER LINER			

FIG. X1.1 Rating Worksheet Example

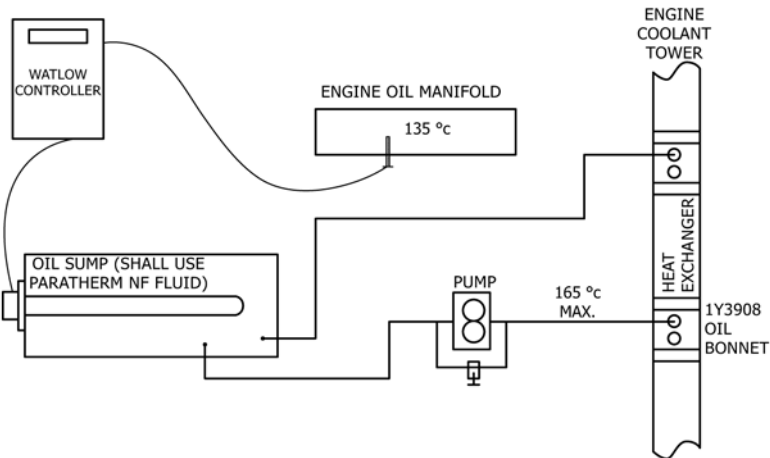
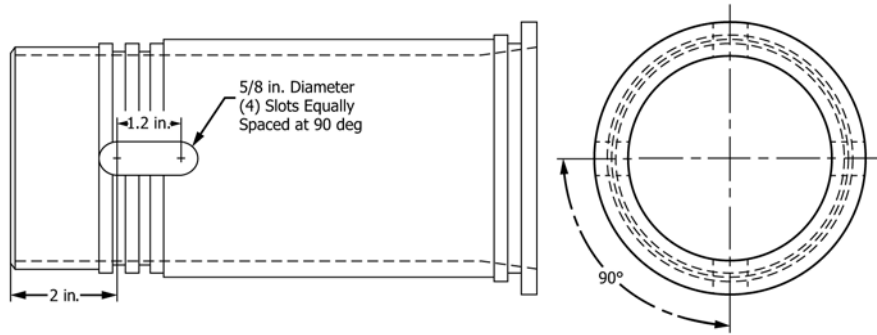

FIG. X1.2 Engine Oil Heating System



NOTE 1—Use a 1Y3555 liner from the 1K/1N test. The liner shall be free of I.D. distortion or surface distress.

FIG. X1.3 Ring Side Clearance Measurement Fixture

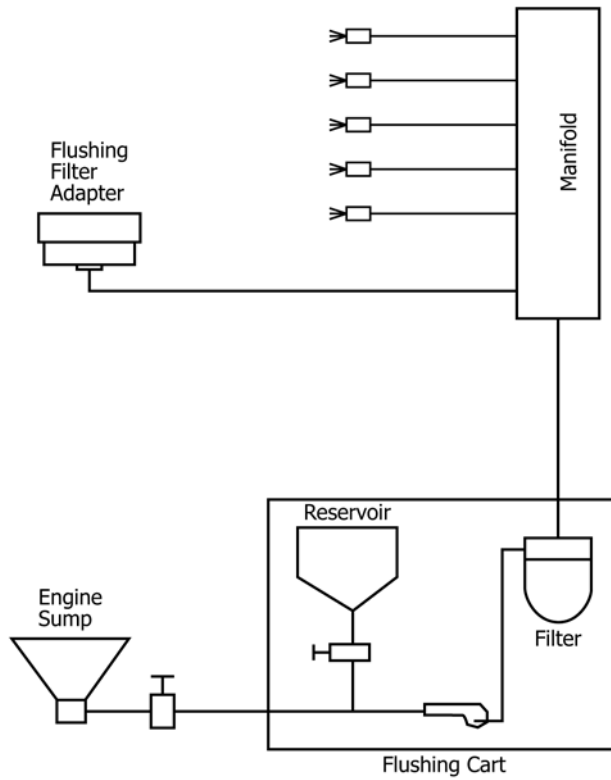

FIG. X1.4 Flushing Cart Flow Schematic

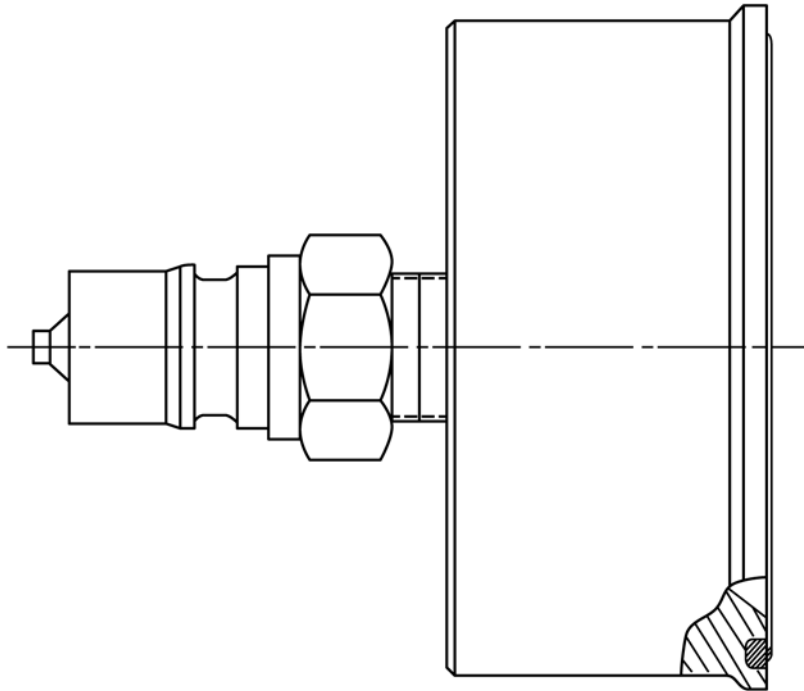
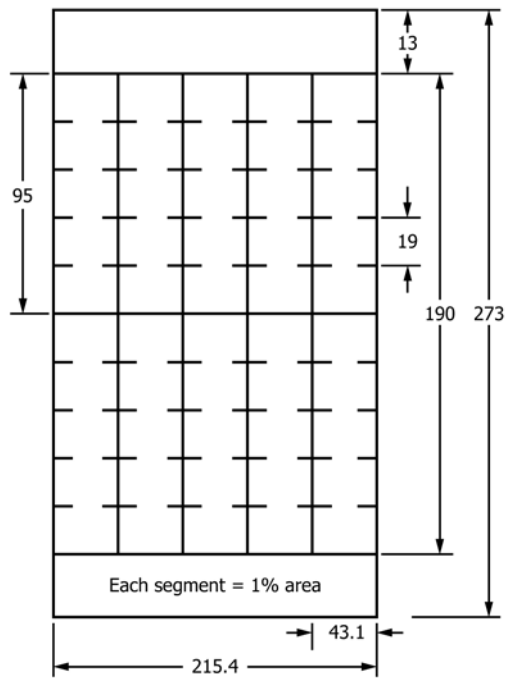

FIG. X1.5 Oil Filter Flushing Adapter Example



NOTE 1—Material is clear plastic; dimensions are in mm.

FIG. X1.6 Bore Polish Grid



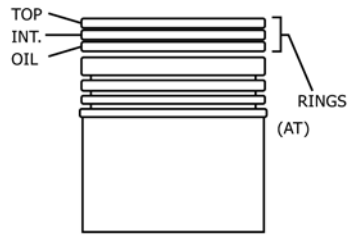

LAB \_\_\_\_\_ STAND NO. \_\_\_\_\_  
 TEST NO. \_\_\_\_\_ ENGINE NO. \_\_\_\_\_  
 CMIR NO. \_\_\_\_\_ OIL CODE \_\_\_\_\_

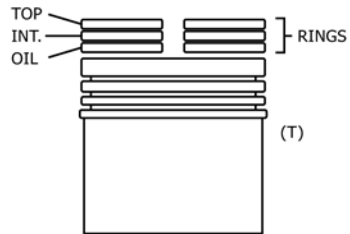

SHOW SKIRT FROM BOTTOM OF PIN  
 BORE TO TOP OF PISTON

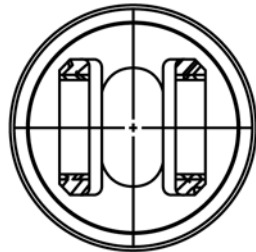
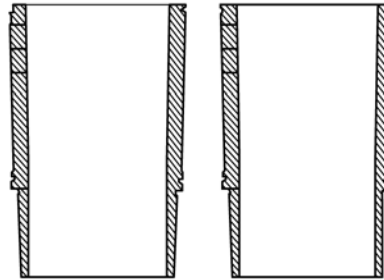

PHOTO OF PISTON UNDERCROWN  
 (Crown Only - No Skirt)

PHOTO OF SECTION LINER  
 SHOW T & AT BORES

FIG. X1.7 Example of Piston, Rings and Liner Photograph Layout

<u>1P TEST SUMMARY SHEET</u>											
OIL CODE NO. _____											
TEST NO.	DATE TEST COMP	OIL CODE NO.	TEST LAB	ENGINE STAND NO.	ENGINE RUN NO.	WDP	TGC	TLC	BSOC g/h 0 - 360	BSOC g/h 0 - 48	BSOC g/h 336-360
<b>TEST DATA</b>											
1ST											
2											
3											
4											
<b>TEST AVG</b>											
1ST											
2											
3											
<b>OUTLIER MIN. LEVEL</b>						(1)	(2)	(4)			
2 TEST AVG. WITH OUTLIER REMOVED											
3 TEST AVG. WITH OUTLIER REMOVED											
<b>ACCEPTANCE LIMITS</b>											
1ST TEST PASS											
2 TEST PASS											
3 TEST PASS											
<b>NOTES:</b>											
(1) WDP 3 TEST AVG + _____											
(2) TGF 3 TEST AVG + _____											
(3) IGF 3 TEST AVG + _____											
(4) TLHC 3 TEST AVG + _____											

NOTE 1—If testing candidate lubricants in accordance with Specification **D4485**, the results of multiple testing should be reported on this form.

**FIG. X1.8 Example of Multiple Test Summary Sheet**

## X2. SAFETY

X2.1 The operating of engine tests can expose personnel and facilities to a number of safety hazards. It is recommended that only personnel who are thoroughly trained and experienced in engine testing should undertake the design, installation, and operation of engine test stands. Each laboratory conducting engine tests should have their test installation inspected and approved by their Safety Department. Personnel working on the engines should be provided with the proper tools, be alert to common sense safety practices and avoid contact with external moving or hot parts. When engines are operating at high speeds, heavy duty guards are required and personnel should be cautioned against working alongside the engine and coupling shaft. Barrier protection should be provided for personnel. All fuel, oil lines, and electrical wiring should be properly routed, guarded, and kept in good order. Scraped knuckles, minor burns, and cuts are common if proper safety precautions are not taken. Safety masks or glasses should always be worn by personnel working on the engines and no loose or flowing clothing should be worn near running engines. The external parts of the engine and the floor area

around the engines should be kept clean and free of oil and fuel spills. In addition, working areas should be free of all tripping hazards. In case of injury, no matter how slight, first aid attention should be applied at once and the incident reported. Leaking fuel represents a fire hazard and exhaust gas fumes are noxious. Do not allow containers of oil or fuel to accumulate in the testing area. The test installation should be equipped with a fuel shut-off valve which is designed to automatically cut off the fuel supply to the engine when the engine is not running. A remote station for cutting off fuel from the test stand is recommended. Suitable interlocks should be provided so that the engine is automatically shut down when any of the following events occur: the engine dynamometer loses field current, engine over-speeds, low oil pressure, high water temperature, exhaust system fails, room ventilation fails, or the fire protection system is activated. Consider an excessive vibration pickup interlock if equipment operates unattended. Fixed fire protection equipment should be provided and dry chemical fire extinguishers should be available at the test stands.

**SUMMARY OF CHANGES**

Subcommittee D02.B0 has identified the location of selected changes to this standard since the last issue (D6681 – 16) that may impact the use of this standard. (Approved May 1, 2017.)

(1) Subsection **10.14**, humidity calibration requirements revised, and use of an equivalent measurement device to a chilled mirror dew point hygrometer is now allowed.

Subcommittee D02.B0 has identified the location of selected changes to this standard since the last issue (D6681 – 15) that may impact the use of this standard. (Approved April 1, 2016.)

(1) Subsection **10.10** revised to delete the requirement for test validation.

*ASTM International takes no position respecting the validity of any patent rights asserted in connection with any item mentioned in this standard. Users of this standard are expressly advised that determination of the validity of any such patent rights, and the risk of infringement of such rights, are entirely their own responsibility.*

*This standard is subject to revision at any time by the responsible technical committee and must be reviewed every five years and if not revised, either reapproved or withdrawn. Your comments are invited either for revision of this standard or for additional standards and should be addressed to ASTM International Headquarters. Your comments will receive careful consideration at a meeting of the responsible technical committee, which you may attend. If you feel that your comments have not received a fair hearing you should make your views known to the ASTM Committee on Standards, at the address shown below.*

*This standard is copyrighted by ASTM International, 100 Barr Harbor Drive, PO Box C700, West Conshohocken, PA 19428-2959, United States. Individual reprints (single or multiple copies) of this standard may be obtained by contacting ASTM at the above address or at 610-832-9585 (phone), 610-832-9555 (fax), or [service@astm.org](mailto:service@astm.org) (e-mail); or through the ASTM website ([www.astm.org](http://www.astm.org)). Permission rights to photocopy the standard may also be secured from the Copyright Clearance Center, 222 Rosewood Drive, Danvers, MA 01923, Tel: (978) 646-2600; <http://www.copyright.com/>*