



# Standard Test Method for Determining the Flexural Creep Stiffness of Asphalt Binder Using the Bending Beam Rheometer (BBR)<sup>1</sup>

This standard is issued under the fixed designation D6648; the number immediately following the designation indicates the year of original adoption or, in the case of revision, the year of last revision. A number in parentheses indicates the year of last reapproval. A superscript epsilon ( $\epsilon$ ) indicates an editorial change since the last revision or reapproval.

## 1. Scope<sup>2</sup>

1.1 This test method covers the determination of the flexural-creep stiffness or compliance and  $m$ -value of asphalt binders by means of a bending beam rheometer. It is applicable to material having flexural-creep stiffness values in the range of 20 MPa to 1 GPa (creep compliance values in the range of 50  $\text{nPa}^{-1}$  to 1  $\text{nPa}^{-1}$ ) and can be used with unaged material or with materials aged using aging procedures such as Test Method D2872 or Practice D6521. The test apparatus may be operated within the temperature range from  $-36^\circ\text{C}$  to  $0^\circ\text{C}$ .

1.2 Test results are not valid for test specimens that deflect more than 4 mm or less than 0.08 mm when tested in accordance with this test method.

1.3 *This standard does not purport to address all of the safety concerns, if any, associated with its use. It is the responsibility of the user of this standard to establish appropriate safety and health practices and determine the applicability of regulatory limitations prior to use.*

## 2. Referenced Documents

### 2.1 ASTM Standards:<sup>3</sup>

C802 Practice for Conducting an Interlaboratory Test Program to Determine the Precision of Test Methods for Construction Materials

D140 Practice for Sampling Bituminous Materials

D2872 Test Method for Effect of Heat and Air on a Moving Film of Asphalt (Rolling Thin-Film Oven Test)

D6521 Practice for Accelerated Aging of Asphalt Binder Using a Pressurized Aging Vessel (PAV)

D6373 Specification for Performance Graded Asphalt Binder

E77 Test Method for Inspection and Verification of Thermometers

2.2 DIN Standard:<sup>4</sup>  
43760

## 3. Terminology

### 3.1 Definitions:

3.1.1 *asphalt binder,  $n$* —an asphalt-based cement that is produced from petroleum residue either with or without the addition of modifiers.

3.1.2 *physical hardening,  $n$* —a time-dependent, reversible stiffening of asphalt binder that typically occurs when the binder is stored below room temperature.

### 3.2 Definitions of Terms Specific to This Standard:

3.2.1 *contact load,  $n$* —the load,  $P_c$ , required to maintain positive contact between the test specimen, supports, and the loading shaft;  $35 \pm 10$  mN.

3.2.2 *flexural creep compliance,  $D(t)$ ,  $n$* —the ratio obtained by dividing the maximum bending strain (see Eq X1.5) in a beam by the maximum bending stress (Eq X1.4). The flexural creep stiffness is the inverse of the flexural creep compliance.

3.2.3 *flexural creep stiffness,  $S_c(t)$ ,  $n$* —the creep stiffness obtained by fitting a second order polynomial to the logarithm of the measured stiffness at 8.0, 15.0, 30.0 60.0, 120.0, and 240.0 s and the logarithm of time (see Eq 5, section 14.4).

3.2.4 *measured flexural creep stiffness,  $S_m(t)$ ,  $n$* —the ratio (see Eq 3, section 14.2) obtained by dividing the measured maximum bending stress (see X1.4) by the measured maximum bending strain (see Eq X1.5). Flexural creep stiffness has been used historically in asphalt technology while creep compliance is commonly used in studies of viscoelasticity.

3.2.5  *$m$ -value,  $n$* —the absolute value of the slope of the logarithm of the stiffness curve versus the logarithm of time (see Eq 6, section 14.5).

3.2.6 *test load,  $n$* —the load,  $P_t$ , of 240-s duration used to determine the stiffness of the asphalt binder being tested;  $980 \pm 50$  mN.

<sup>4</sup> Deutsches Institut fuer Normung (German Standards Institute), Beuth Verlag GmbH, Burggrafenstrasse 6, 1000 Berlin 30, Germany.

<sup>1</sup> This test method is under the jurisdiction of ASTM Committee D04 on Road and Paving Materials and is the direct responsibility of Subcommittee D04.44 on Rheological Tests.

Current edition approved Oct. 1, 2016. Published October 2016. Originally approved in 2001. Last previous edition approved in 2008 as D6648 – 08. DOI: 10.1520/D6648-08R16.

<sup>2</sup> This standard is based on SHRP Product 1002.

<sup>3</sup> For referenced ASTM standards, visit the ASTM website, www.astm.org, or contact ASTM Customer Service at service@astm.org. For *Annual Book of ASTM Standards* volume information, refer to the standard's Document Summary page on the ASTM website.

3.2.7 *zero load cell reading*—the load indicated by the data acquisition system when the shaft is free floating in the bath and at the position that occurs when first making contact with a test specimen.

**4. Summary of Test Method**

4.1 The bending beam rheometer is used to measure the mid-point deflection of a simply supported prismatic beam of asphalt binder subjected to a constant load applied to its mid-point. The device operates only in the loading mode; recovery measurements cannot be obtained with the bending beam rheometer.

4.2 A prismatic test specimen is placed in the controlled temperature fluid bath and loaded with a constant test load for 240.0 s. The test load ( $980 \pm 50$  mN) and the mid-point deflection of the test specimen are monitored versus time using a computerized data acquisition system.

4.3 The maximum bending stress at the midpoint of the test specimen is calculated from the dimensions of the test specimen, the distance between the supports, and the load applied to the test specimen for loading times of 8.0, 15.0, 30.0, 60.0, 120.0, and 240.0 s. The maximum bending strain in the test specimen is calculated from the dimensions of the test specimen and the deflection for the same loading times. The stiffness of the test specimen for the specific loading times is calculated by dividing the maximum bending stress by the maximum bending strain.

**5. Significance and Use**

5.1 The temperatures for this test are based upon the winter temperature experienced by the pavement in the geographical area for which the asphalt binder is intended.

5.2 The flexural creep stiffness or flexural creep compliance, determined from this test, describes the low-temperature stress-strain-time response of asphalt binder at the test temperature within the range of linear viscoelastic response.

5.3 The low-temperature thermal cracking performance of asphalt pavements is related to the creep stiffness and the m-value of the asphalt binder contained in the mix.

5.4 The creep stiffness and the m-value are used as performance-based specification criteria for asphalt binders in accordance with Specification D6373.

**6. Interferences**

6.1 Measurements for which the mid-point deflections of the test specimen is greater than 4.0 mm are suspect. Strains in excess of this value may exceed the linear response of asphalt binders.

6.2 Measurements for which the mid-point deflections of the test specimen are less than 0.08 mm are suspect. When the mid-point deflection is less than 0.08 mm, the test system resolution may not be sufficient to produce reliable test results.

**7. Apparatus**

7.1 A bending beam rheometer (BBR) test system consisting of the following: (1) a loading frame with test specimen supports, (2) a controlled temperature liquid bath which maintains the test specimen at the test temperature and provides a buoyant force to counterbalance the force resulting from the mass of the test specimen, (3) a computer-controlled data acquisition system, (4) test specimen molds, and (5) items for verifying and calibrating the system.

7.2 *Loading Frame*—A frame consisting of a set of sample supports, a blunt-nosed shaft to apply the load to the midpoint of the test specimen, a load cell mounted in line with the loading shaft, a means for zeroing the load applied to the test specimen, a means for applying a constant load to the test specimen and a deflection measuring transducer attached to the loading shaft. A schematic of the device is shown in Fig. 1.

7.3 *Loading System*—A loading system that is capable of applying a contact load of  $35 \pm 10$  mN to the test specimen and maintaining a test load of  $980 \pm 50$  mN within  $\pm 10$  mN.

7.3.1 *Loading System Requirements*—The rise time for the test load shall be less than 0.5 s. The rise time is the time required for the load to rise from the  $35 \pm 10$  mN contact load to the  $980 \pm 50$  mN test load. During the rise time the system shall dampen the test load to  $980 \pm 50$  mN. Between 0.5 and 5.0 s, the test load shall be within  $\pm 50$  mN of the average test

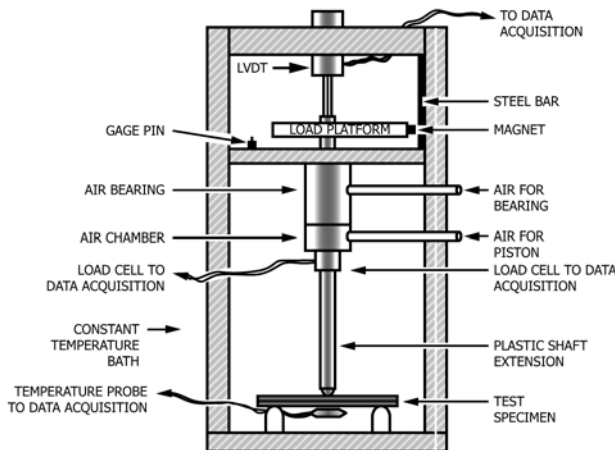

FIG. 1 Schematic of Test Device

load, and thereafter shall be within  $\pm 10$  mN of the average test load. Details of the loading pattern are shown in Fig. 2.

7.3.2 *Loading Shaft*—A loading shaft continuous and in line with the load cell and deflection measuring transducer with a spherically shaped end  $6.3 \pm 0.3$  mm in radius.

7.3.3 *Load Cell*—A load cell to measure the contact load and the test load. It shall have a minimum capacity of no less than 2.00 N and a resolution of at least 2.5 mN. It shall be mounted in line with the loading shaft and above the fluid level in the controlled temperature bath.

7.3.4 *Linear Variable Differential Transducer (LVDT)*—A linear variable differential transducer or other suitable device to measure the deflection of the test specimen. It shall have a linear range of at least 6 mm, and be capable of resolving linear movement of 2.5  $\mu$ m. It shall be mounted axially with and above the loading shaft.

7.3.5 *Sample Supports*—Two stainless steel or other non-corrosive metal supports with a  $3.0 \pm 0.3$  mm contact radius and spaced  $102 \pm 1.0$  mm apart. The spacing of the supports shall be measured to  $\pm 0.3$  mm and the measured value shall be used in the calculations in Section 14. The supports shall be dimensioned to ensure that the test specimen remains in contact with the radiused portion of the support during the entire test. See Fig. 3.

7.3.5.1 The width of the test specimen support that contacts the test specimen shall be  $9.50 \pm 0.25$  mm. See Fig. 3.

7.3.5.2 A vertical alignment pin 2 to 4 mm in diameter shall be provided at the back of each support to align the test specimen on the supports. The front face of the pins shall be  $6.75 \pm 0.25$  mm from the middle of the support. See Fig. 3.

7.4 *BBR Thermometric Device*—A calibrated thermometric device integral to the BBR and capable of measuring the temperature to 0.1°C over the range from  $-36^\circ\text{C}$  to  $0^\circ\text{C}$  with its thermal sensor (probe) mounted within 50 mm of the geometric center of the test specimen.

NOTE 1—The required temperature measurement can be accomplished with an appropriately calibrated thermometric device (platinum resistance or thermistor based). Calibration of the thermometric device can be

verified as per section 11.5. A platinum resistance thermometric device meeting DIN Standard 43760 (Class A) is recommended for this purpose.

7.5 *Controlled-Temperature Fluid Bath*—A controlled-temperature liquid bath capable of maintaining the temperature at all points in the bath to within  $\pm 0.1^\circ\text{C}$  of the test temperature in the range of  $-36^\circ\text{C}$  to  $0^\circ\text{C}$ . Placing a test specimen in the bath may cause the bath temperature to fluctuate  $\pm 0.2^\circ\text{C}$  from the target test temperature. Consequently bath fluctuations of  $\pm 0.2^\circ\text{C}$  during iso-thermal conditioning shall be allowed.

7.5.1 *Bath Agitator*—A bath agitator for maintaining the required temperature homogeneity with agitation intensity such that the fluid currents do not disturb the testing process and mechanical noise caused by vibrations is less than the resolution specified in 7.3.3 and 7.3.4.

7.5.2 *Circulating Bath (Optional)*—A circulating bath separate from the test frame, which pumps the bath fluid through the test bath. If used, vibrations from the circulating system shall be isolated from the bath test chamber so that mechanical noise is less than the resolution specified in 7.3.3 and 7.3.4.

7.6 *Data Acquisition and Control Components*—A data acquisition system that resolves loads to the nearest 2.5 mN, test specimen deflection to the nearest 2.5  $\mu$ m, and bath fluid temperature to the nearest 0.1°C. The data acquisition system shall sense the point in time when the signal to switch from the contact load to the test load is activated. This time shall be used as the zero loading time for the test load and deflection signals. Using this time as the reference for zero time, the data acquisition system shall provide a record of subsequent load and deflection measurements at 8.0, 15.0, 30.0, 60.0, 120.0, and 240.0 s.

7.6.1 *Filtering of Acquired Load and Deflection Signals*—The load and deflection signals shall be filtered with a low pass analog or digital (or both) filter that removes components with frequencies greater than 4 Hz from the load and deflection signals. Filtering may be accomplished by averaging five or more digital signals equally spaced in time about the time at which the signal is reported. The averaging shall be over a time

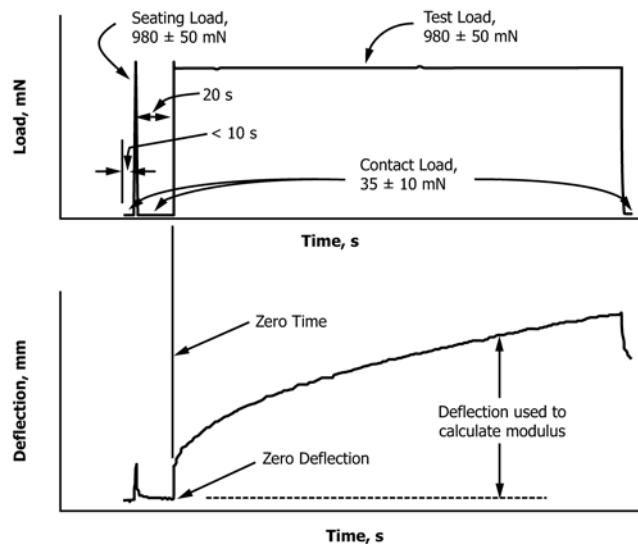

FIG. 2 Definition of Loading Pattern

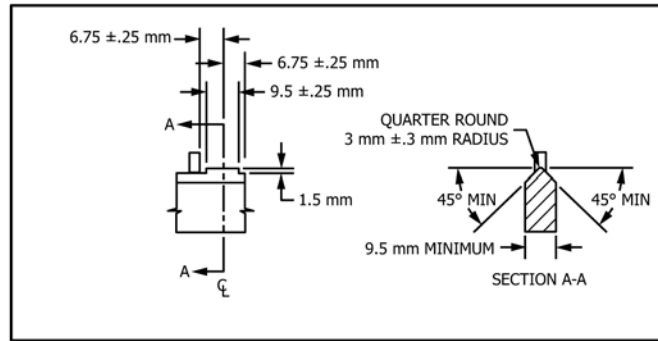

FIG. 3 Schematic of Specimen Supports

period less than or equal to  $\pm 0.2$  s of the reporting time. For example, the load and deflection signals at 8.0 s may be the average of signals at 7.8, 7.9, 8.0, 8.1, 8.2 s.

7.7 Test Specimen Molds—Test specimen molds with interior dimensions of  $6.35 \pm 0.05$  mm wide by  $12.70 \pm 0.05$  mm deep by  $127 \pm 5$  mm long fabricated from aluminum or stainless steel as shown in Fig. 4, or from silicone rubber as shown in Fig. 5.

7.7.1 The thickness of the two spacers used for each mold (small end pieces used in the metal molds) shall be measured with a micrometer and shall meet the requirements of Section 7.7. The measurements shall be recorded as part of the laboratory quality control program.

7.8 Items for Calibration or Verification—The following items are required to verify and calibrate the BBR.

7.8.1 Stainless Steel (Thick) Beam for Compliance Measurement and Load Cell Calibrations—One stainless steel beam  $6.4 \pm 0.3$  mm thick by  $12.7 \pm 0.3$  mm wide by  $127 \pm 5$  mm long for measuring system compliance and calibrating load cell. When this beam is used to measure the thickness of test specimens as per section 13.2, the thickness of this beam shall be measured to the nearest 0.01 mm. This measurement shall be used in the calculation of the thickness of the test specimens when using the equations in section 13.2.3.1.

7.8.2 Stainless Steel (Thin) Beam for Overall System Check—One stainless steel beam 1.0 to 1.6 mm thick by  $12.7 \pm 0.1$  mm wide by  $127 \pm 5$  mm long with an elastic modulus reported to three significant figures by the manufacturer of the BBR. The manufacturer of the BBR shall measure and report the thickness of this beam to the nearest 0.01 mm and the width to the nearest 0.05 mm. The dimensions of the beam shall be used to calculate the modulus of the beam during the overall system check (see section 11.3).

7.8.3 Standard Masses—Standard masses for verification and calibration as follows:

7.8.3.1 Verification of Load Cell Calibration—One or more masses totaling  $100.0 \pm 0.2$  g and two masses of  $2.0 \pm 0.2$  g each for verifying the calibration of the load cell (see section 11.3).

7.8.3.2 Calibration of Load Cell—Four masses each of known mass  $\pm 0.2$  g, and equally spaced in mass over the range of the load cell (see A1.2).

7.8.3.3 Daily Overall System Check—Two or more masses, each of known mass to  $\pm 0.2$  g for conducting overall system check as specified by the manufacturer (see section 11.4).

7.8.3.4 Accuracy of Masses—Accuracy of the masses in section 7.8.3 shall be verified at least once each every three years.

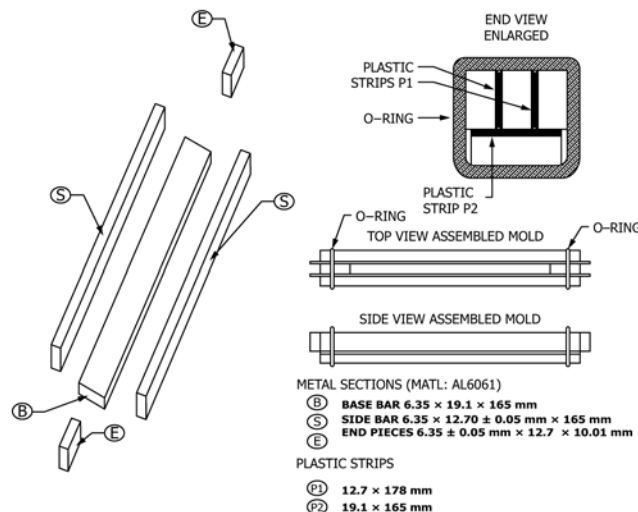

FIG. 4 Dimensions and Specifications for Aluminum Molds

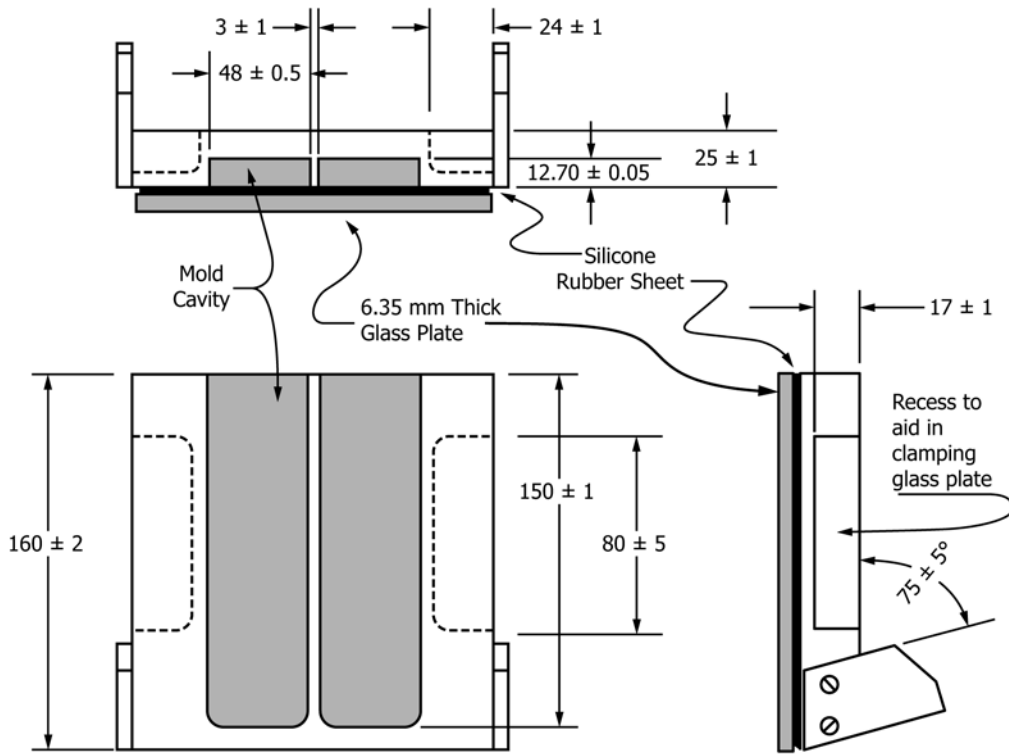

FIG. 5 Dimensions for Fixture for Silicone Molds

7.8.4 *Typical Gage Block*—A stepped gage block with thickness measured to  $\pm 5 \mu\text{m}$  for calibrating and for verifying the calibration of the displacement transducer (see Fig. 6 for typical design).

7.9 *Calibrated Thermometric Device*—Portable calibrated thermometric device for verification of the BBR thermometric device of suitable range with resolution of  $0.1^\circ\text{C}$  as per 7.9.1 or 7.9.2.

7.9.1 A partial immersion liquid-in-glass thermometer with an ice point and calibrated in accordance with Test Method E77 at least once per year. A suitable thermometer is designated ASTM 133C-00.

7.9.2 A thermometric device based upon a platinum or thermistor sensor calibrated at least once per year.

7.10 *Alignment Fixture (Optional)*—A fixture supplied by the manufacturer to align the loading shaft so that it contacts

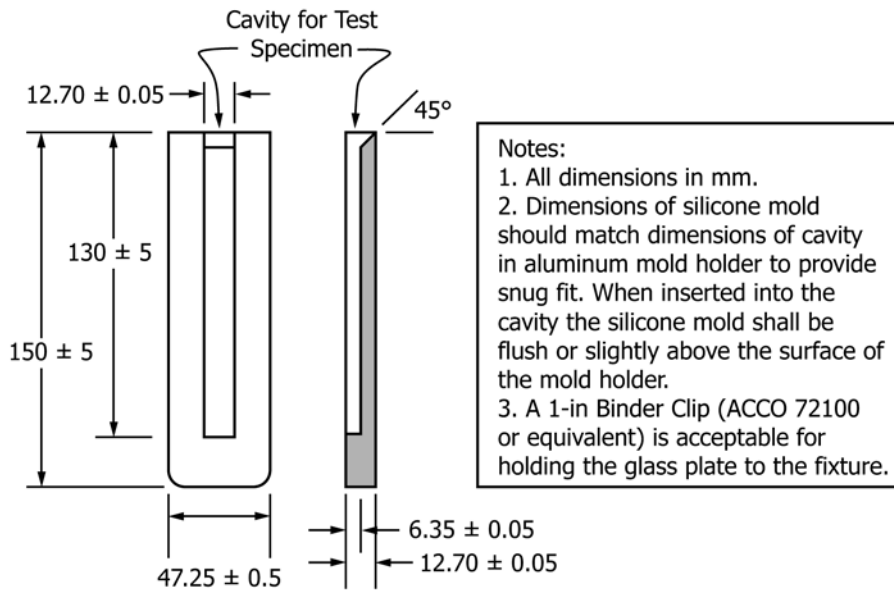

FIG. 6 Silicone Rubber Mold

the specimen at the longitudinal and transverse center of the loaded portion of the test specimen.

## 8. Materials

8.1 *Sheeting for Metal Molds*—Used to line the interior faces of the three long metal mold sections. Hot asphalt binder shall not distort the sheeting when the test specimen is prepared. The sheeting shall be sufficiently rigid so that the shrinkage of the asphalt binder does not distort the sheeting or pull the sheeting from the metal surfaces when the test specimen is cooled.

8.1.1 Clear plastic sheeting 0.08 to 0.15 mm thick. Transparency film sold for use with laser printers has been found suitable for this purpose.

8.1.2 *Silicone coated release paper sheeting for metal molds (Optional)*—Silicone coated release paper 4.0 to 5.0 mil thick and coated on both sides.

8.2 *Sheeting for Silicone Molds*—Silicone rubber sheeting for lining the space between the glass plate and the silicone mold. Hot asphalt binder shall not distort the sheeting when the test specimen is prepared. The sheeting shall be sufficiently rigid so that the shrinkage of the asphalt binder does not distort the sheeting or pull the sheeting from the glass when the test specimen is cooled.

NOTE 2—Silicone rubber sheeting,  $10 \pm 0.5$  mm thick, Shore A Hardness 60 has been found acceptable for this purpose.<sup>5</sup>

8.3 *Material for Adhering Strips to Metal Mold Faces*—Used to hold the plastic or silicone strips to the interior faces of the three long metal mold sections. Petroleum-based grease, a mixture such as glycerin and Dextrin, talc or Kaolin (china clay) or Versamid Resin and mineral oil used to coat the bottom and sides of mold to prevent the asphalt binder from sticking to the mold. Other materials may be used for this purpose if they have been shown not to affect the physical properties of the test specimen. Silicone grease shall not be used. No silicone-based products shall be used.

8.4 *Release Agent for Coating Metal Molds*—Used to coat the vertical interior end faces of the metal molds. See Section 8.3.

8.5 *Bath Fluid*—A bath fluid that is not absorbed by or does not affect the properties of the asphalt binder being tested. The mass density of the fluid shall not exceed  $1.05 \text{ g/cm}^3$  at the test temperature as measured with suitable hydrometers. The bath fluid shall be optically clear at the test temperature.

8.5.1 Suitable bath fluids include, but are not limited to ethanol, methanol, stabilized isopropanol, and glycol-methanol-water mixtures (for example, 60 % glycol, 15 % methanol, and 25 % water). Silicone fluids or mixtures containing silicones shall not be used.

## 9. Hazards

9.1 Observe standard laboratory safety procedures when handling hot asphalt binder and preparing test specimens.

9.2 Alcohol baths are flammable and toxic. Locate the controlled temperature bath in a well-ventilated area away from sources of ignition. Avoid breathing alcohol vapors, and contact of the bath fluid with the skin.

9.3 Contact between the bath fluid and skin at the lower temperatures used in this test method can cause frostbite.

## 10. Preparation of Apparatus

10.1 Clean the supports, loading head, and bath fluid of any particulates and coatings as necessary.

NOTE 3—Because of the brittleness of asphalt binder at the specified test temperatures, small fragments of asphalt binder can be introduced into the bath fluid. If these fragments are present on the supports or the loading head, the measured deflection may be affected. The small fragments, because of their small size, will deform under load and add an apparent deflection to the true deflection of the test specimen. Filtration of the bath fluid will aid in preserving the required cleanliness.

10.2 Select the test temperature and adjust the bath fluid to the selected temperature. Allow the bath to equilibrate to the test temperature  $\pm 0.1^\circ\text{C}$  before conducting a test.

10.3 Turn on the loading and data acquisition system and start the software as explained in the manufacturer's manual. Allow the data acquisition system and computer to warm up according to the manufacturer's instruction manual before operating the BBR.

## 11. Verification of the Calibration of the BBR Components

NOTE 4—Additional verification steps may be performed at the option of the manufacturer. At the option of the manufacturer, the verification and calibration steps may be combined.

11.1 *Verification of Displacement Transducer*—On each day, before any tests are conducted, verify the calibration of the displacement transducer using a stepped-gage block of known dimensions similar to the one shown in Fig. 6. With the loading frame mounted in the bath at the test temperature remove all beams from the supports and place the gage block on a reference platform underneath the loading shaft according to the instructions supplied by the instrument manufacturer. Apply a  $100 \pm 0.2$  g mass to the loading shaft and measure the rise of the steps with the displacement transducer. Compare the measured values as indicated by the data acquisition system with the known dimensions of the gage. If the known dimensions as determined from the gage block and the dimensions indicated by the data acquisition system differ by more than  $\pm 15 \mu\text{m}$ , calibration is required. Perform the calibration as per A1.1 and repeat section 11.1. If the requirements of section 11.1 cannot be met after calibration, discontinue use of the device and consult the manufacturer.

11.2 *Verification of Freely Operating Air Bearing*—On each day, before any tests are conducted, verify that the air bearing is operating freely and is free of friction. Sections 11.2.1 and 11.2.2 shall be used to verify that the shaft is free of friction. If the requirements of 11.2.1 and 11.2.2 are not satisfied, friction is present in the air bearing. Clean the shaft and adjust the clearance of the displacement transducer as per the manufacturer's instructions. If this does not eliminate the friction, discontinue use of the BBR and consult the manufacturer.

<sup>5</sup> Available from McMaster-Carr Supply Company, P.O. Box 440, New Brunswick, NJ 08903, Silicone rubber sheeting, Part No. 863K43:Shore A Hardness 60.

NOTE 5—Friction may be caused by a poorly adjusted displacement transducer core that rubs against its housing, an accumulation of asphalt binder on the loading shaft, by oil or other particulates in the air supply, and other causes.

11.2.1 Place the thin steel beam (section 7.8.2) on the sample supports and apply a  $35 \pm 10$  mN load to the beam using the zero load regulator. Observe the reading of the LVDT as indicated by the data acquisition system. Gently grasp the loading platform and lift the shaft upwards approximately 5 mm by observing the reading of the LVDT. When the shaft is released it shall immediately float downward and make contact with the beam.

11.2.2 Remove any beams from the supports. Use the zero load regulator to adjust the loading shaft so that it is free floating at the approximate midpoint of its vertical travel. Gently add a coin or other mass of approximately 2 g (for example, copper U.S. penny) to the loading shelf. The shaft shall slowly drop downward under the mass.

11.3 *Verification of Load Cell*—Verify the calibration of the load cell as follows:

11.3.1 *Contact Load*—On each day before any tests are conducted, verify the calibration of the load cell in the range of the contact load. Place the 6.35 mm thick stainless steel compliance beam (Section 7.8.1) on the supports. Apply a  $20 \pm 10$  mN load to the beam using the zero load pressure regulator. Add the  $2.0 \pm 0.2$  g mass as specified in section 7.8.3 to the loading platform. The increase in the load displayed by the data acquisition system shall be  $20 \pm 5$  mN. Add a second  $2.0 \pm 0.2$  g mass to the loading platform. The increase in the load displayed by the data acquisition system shall be  $20 \pm 5$  mN. If the increases in displayed load are not  $20 \pm 5$  mN, calibration is required. Perform the calibration as per A1.2 and repeat section 11.3.1. If the requirements of section 11.3.1 cannot be met after calibration, discontinue use of the device and consult the manufacturer.

11.3.2 *Test Load*—On each day, before any tests are conducted, verify the calibration of the load cell in the range of the test load. Place the 6.35 mm thick stainless steel compliance beam (section 7.8.1) on the supports. Use the zero load regulator (contact load) to apply a  $20 \pm 10$  mN load to the beam. Add the 100 g mass to the loading platform. The increase in the load displayed by the data acquisition system shall be  $981 \pm 5$  mN. Otherwise, calibrate the load cell in accordance with A1.2 and repeat section 11.3.2. If the requirements of section 11.3.2 cannot be met after calibration, discontinue use of the device and consult the manufacturer.

11.3.3 *Verification of Zero Load Cell Reading*—On each day, before any tests are conducted and with the loading frame mounted in the bath, bring the loading shaft to the vertical position that it will occupy at the start of a test (starting position).

11.3.3.1 The vertical position of the shaft at the start of a test when the contact load is applied shall be determined by placing the thick stainless steel beam (See Section 7.8.1) on the supports and placing a 100 g mass on the loading platform. The reading displayed for the position transducer indicates the approximate position of the shaft when a 6.35-mm thick beam is tested.

NOTE 6—The load indicated by the load cell is affected by the buoyant force caused by submergence of the shaft in the bath fluid. Changes in the level of the bath fluid and the density of the bath fluid can also affect the zero of the load cell.

11.3.3.2 While free floating at this position the BBR device shall indicate  $0 \pm 5$  mN. If the requirements of Section 11.3.3 cannot be met after calibration, discontinue use of the device and consult the manufacturer.

11.4 *Daily Overall System Check*—On each day, before any tests are conducted and with the loading frame mounted in the bath, perform a check on the overall operation of the system. Place the 1.0 to 1.6 mm thick stainless steel (thin) beam of known modulus as described in section 7.8.2 on the sample supports. Following the instructions supplied by the manufacturer, place the beam on the supports and apply a 50 or  $100.0 \pm 0.2$  g initial mass (491 or 981 mN  $\pm 2$  mN) to the beam to ensure that the beam is seated and in full contact with the supports. Following the manufacturer's instructions, apply a second additional load of 100 to  $300.0 \pm 0.2$  g to the beam. The software provided by the manufacturer shall use the change in load and associated change in deflection to calculate the modulus of the beam to three significant figures. The modulus reported by the software shall be within 10 percent of the modulus reported by the manufacturer of the BBR, otherwise the overall operation of the BBR shall be considered suspect and the manufacturer of the device shall be consulted.

11.5 *Verification of Thermometric Device*—On each day before any tests are conducted, and whenever the test temperature is changed, verify calibration of the temperature detector by using a calibrated thermometric device as described in section 7.9. With the loading frame placed in the liquid bath, immerse the probe of the thermometric device in the liquid bath close to the temperature transducer and compare the temperature indicated by the thermometric device to the temperature displayed by the data acquisition system. If the temperature indicated by the data acquisition system does not agree with the thermometric device within  $\pm 0.1^\circ\text{C}$ , calibration as per A1.3 is required.

11.6 *Verification of Front-to-Back Alignment of Loading Shaft*—When the instrument is installed or otherwise disturbed through handling such that the alignment of the loading shaft may be suspect, the alignment of the loading shaft with the center of the sample supports shall be checked with an alignment gage supplied by the manufacturer or by measurement as follows: Cut a strip of white paper about 25 mm in length and slightly narrower than the width of the compliance beam. Stick the paper strip to the center of the compliance beam with Scotch tape. Move the frame out of the bath, place the compliance beam on the supports and place a small section of carbon paper over the bond paper. With the air pressure applied to the air bearing, push the shaft downward causing the carbon paper to make an imprint on the white paper. Remove the beam and measure the distance from the center of the imprint to each edge of the beam with a pair of vernier calipers. The difference between the two measurements shall be 1.0 mm or less. If this requirement is not met, contact the manufacturer of the device.

## 12. Preparation of Molds and Test Specimens

12.1 *Preparation of Molds*—Each time specimens are prepared, prior to filling the molds, prepare the molds as described in Section 12.1 or 12.2.2.

NOTE 7—Silicone molds may be used at the option of the user but metal molds shall be used for reference purposes.

12.1.1 *Preparation of Metal Molds*—Remove any deposits of asphalt binder, grease or other residue from the molds. Visually inspect the metal mold components to verify that they are free of dings, nicks, or burrs that would affect the spacing of the side plates and reject those components with such dings, nicks, and burrs. To prepare the metal molds, spread a very thin layer of the material described in 8.3 on the interior faces of the three long metal mold sections. Use only the amount of grease necessary to hold the plastic or silicone strips to the metal. Strips that have become distorted from previous heating shall not be used. Place the strips over the metal faces and rub the strips with firm finger pressure. Assemble the mold as shown in Fig. 4 using the rubber O-rings to hold the pieces of the mold together. Inspect the mold and press the plastic or silicone film against the metal to force out any air bubbles. If air bubbles remain, disassemble the mold and recoat the metal faces with grease. Cover the inside faces of the two end pieces with a thin film of the glycerol and talc mixture to prevent the asphalt binder from sticking to the metal end pieces. After assembly, keep the mold at room temperature until pouring the asphalt binder.

12.1.2 *Preparation of Silicone Molds*—Remove asphalt binder, grease or other residue by wiping the molds with a clean, dry cloth. Do not soak the molds in an organic solvent. Prepare silicone rubber molds by assembling the two mold sections as shown in Fig. 5.

NOTE 8—A cloth moistened with a volatile solvent that is essentially residue free, such as acetone or heptane, is satisfactory for this purpose as well as for removing markings on the molds. Allow the molds to dry at ambient temperature for at least 10 min prior to use.

### 12.2 Preparation of Test Specimen:

12.2.1 If unaged binder is to be tested, obtain test samples according to Practice D140. Laboratory-conditioned samples or samples of asphalt binder recovered from mixtures shall be obtained in accordance with appropriate test methods or methods of practice.

12.2.2 Heat the asphalt binder in an oven set at  $168 \pm 5^\circ\text{C}$  until the asphalt binder is sufficiently fluid to pour and stir gently to homogenize the sample. If sufficiently fluid to pour the asphalt binder may be poured directly from PAV residue that has been degassed as specified in D6521.

NOTE 9—If the asphalt binder does not pour easily when heated in an oven set to no more than  $173^\circ\text{C}$  it may be heated at a higher temperature in an oven until it is sufficiently fluid to pour. If the binder is heated in an oven set to a temperature greater than  $173^\circ\text{C}$  the oven temperature and time above  $173^\circ\text{C}$  shall be noted in the report.

12.3 *Molding and Trimming Test Specimens*—Mold test specimens according to section 12.3.1 or 12.3.2.

12.3.1 *Molding Test Specimens (Metal Mold)*—With the mold at room temperature, begin pouring the binder from one end of the mold and move toward the other end, slightly

overflowing the mold. When pouring, hold the sample container 20 to 30 mm from the top of the mold, pouring continuously toward the other end in a single pass. Place the filled mold on the laboratory bench and allow the mold to cool for 45 to 60 min to room temperature. After cooling to room temperature, trim the exposed face of the cooled specimens flush with the top of the mold using a hot knife or a heated spatula.

NOTE 10—Immediately before trimming, a heated spatula may be brought into momentary contact with the surface of the asphalt binder so that the surface of the asphalt binder is softened just sufficiently to flatten the surface. This process is often referred to a “buttering” and has been shown to improve the quality of test specimens prepared from the stiffer grades of binders. This procedure should not be used with the softer binder grades.

12.3.2 *Molding Test Specimen (Silicone Rubber Mold)*—If the viscosity of the binder warrants, the operator may preheat the silicone rubber mold in its aluminum fixture in a  $135^\circ\text{C}$  oven for up to 30 min prior to filling. Fill the mold from the top of the mold in a slow steady manner taking care not to entrap air bubbles. Fill the mold to the top with no appreciable overfilling. Allow the mold and its contents to cool to room temperature for 45 to 60 min after pouring.

### 12.4 Storing and Demolding Test Specimens:

12.4.1 Store all test specimens in their molds at room temperature prior to testing.

NOTE 11—Time-dependent increases in stiffness can occur when an asphalt binder is stored at room temperature for even short periods of time.

12.4.2 Just prior to demolding, cool the metal or silicone mold containing the test specimen in a cold chamber or liquid bath for no longer than 5 min, but only long enough to stiffen the test specimen so that it can be readily demolded without distortion. In no case shall the sample be exposed to demolding temperatures that are within  $10^\circ\text{C}$  of the test temperature. Do not cool the molds containing the specimens in the test bath because it may cause temperature fluctuations in the bath to exceed  $\pm 0.2^\circ\text{C}$ .

NOTE 12—Excessive cooling may cause unwanted hardening of the asphalt binder, thereby causing increased variability in the test data.

12.4.3 Immediately demold the specimen when it is sufficiently stiff to demold without distortion by disassembling the metal mold or by removing the test specimen from the silicone rubber mold. To avoid distorting the specimen, demold the specimen by sliding the plastic strips and metal side pieces from the mold assembly and gently peeling the plastic or silicone paper strips from the test specimen.

NOTE 13—During demolding, handle the specimen with care to prevent distortion. Full contact at specimen supports is assumed in the analysis. A warped test specimen may affect the measured stiffness and m-value.

NOTE 14—If the plastic or silicone release paper strips stick to the test specimen, the specimen with strips attached may be dipped in a bath as described in 12.4.2 for no more than 5 s to facilitate removal of the strips.

## 13. Procedure

13.1 When testing a specimen for compliance with Specification D6373, select the appropriate test temperature from Specification D6373. After demolding, immediately place the test specimen in the testing bath and condition it at the testing temperature. The seating load shall be applied to the test



specimen within  $60 \pm 5$  minutes after the test specimen is placed in the testing bath. The test specimen shall remain submerged in the bath fluid at the test temperature  $\pm 0.1^\circ\text{C}$  for the entire  $60 \pm 5$  minutes. Testing shall be completed within 4 h after specimens are poured.

NOTE 15—Asphalt binders may harden rapidly when held at low temperatures. This effect, which is called physical hardening, is reversible when the asphalt binder is heated to room temperature or slightly above. Because of physical hardening, conditioning time must be carefully controlled if repeatable results are to be obtained.

13.2 *Test Specimen Thickness Measurement*—The thickness of the test specimen shall be taken as 6.35 mm, the specified thickness of the metal spacers used to mold the test specimen. (See section 7.7.1).

13.2.1 *Optional Methods for Measuring Test Specimen Thickness*—Two optional methods of thickness measurement (Sections 13.2.2 and 13.2.3) may be used at the discretion of the user. Measured insert thickness (section 13.2) shall be used as the reference method for the metal molds. Methods 13.2.2 or 13.2.3 must be used with the silicone molds.

NOTE 16—Measurement of the test specimen thickness in accordance with sections 13.2.2 or 13.2.3 may reduce the variability in the test results but this may be offset by the additional handling required. When using the procedure in section 13.2.2 or 13.2.3, use caution not to warp or distort the test specimen.

13.2.2 *Direct Method*—In using this method, the thickness of the test specimen shall be measured with a thickness gage or similar apparatus. The specimen shall remain submerged at the test temperature  $\pm 0.2^\circ\text{C}$  during the measurement. The thickness shall be obtained at the midpoint of the test specimen to the nearest  $2.5 \mu\text{m}$  and entered into the software by the operator for use in calculating the stiffness of the test specimen.

13.2.3 *Measurement with Displacement Transducer*—The thickness of the test specimen may be measured with the displacement transducer as described below. The thickness may be calculated by hand, using the displacement readings displayed by the instrument or may be entered into the software and calculated automatically. Calculate and report the thickness to the nearest  $50 \mu\text{m}$  for use in calculating the stiffness of the test specimen.

13.2.3.1 Establish the displacement reading corresponding to the top of the supports by placing the 6.35-mm thick stainless steel beam (section 7.8.1) on the supports. Apply a  $35 \pm 10$  mN contact load to the steel beam and record the reading of the displacement transducer as  $R_{s1}$ . Invert the steel beam and obtain a second reading,  $R_{s2}$ . Average the two readings and record the average as  $R_s$ . Calculate the displacement transducer reading that corresponds to the top of the supports (see Fig. 7):

$$R_o = R_s + t_s \quad (1)$$

where:

$R_o$  = displacement transducer reading corresponding to top of supports,

$R_s$  = average of two displacement transducer readings with displacement transducer in contact with top of the steel test specimen, and

$t_s$  = measured thickness of steel beam (section 7.8.1).

13.2.3.2 Establish the thickness of the test specimen immediately before testing by placing the test specimen on the supports. Apply a  $35 \pm 10$  mN contact load to the test specimen and record the reading of the displacement transducer as  $R_{a1}$ . Invert the test specimen and obtain a second reading,  $R_{a2}$ . If the two readings agree within 1.0 mm, average them as  $R_a$ . If the two readings differ by more than 1.0 mm, the flatness of the test specimen is suspect, and it should be discarded. Calculate the thickness of the test specimen as (see Fig. 7):

$$t_a = R_o - R_a \quad (2)$$

where:

$t_a$  = calculated thickness of test specimen,

$R_o$  = displacement transducer reading corresponding to top of supports calculated as per Eq 1, and

$R_a$  = average of two displacement transducer readings with displacement transducer in contact with top of the test specimen.

13.3 *Checking Contact Load and Test Load*—Check the adjustment of the contact load and test load prior to testing each set of tests specimens in accordance with section 13.4.

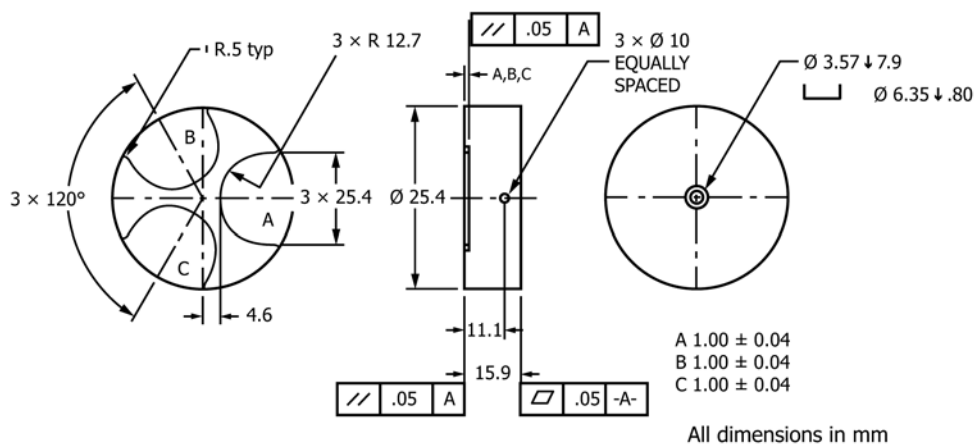

FIG. 7 Typical Gauge Block Used to Calibrate Displacement Transducer

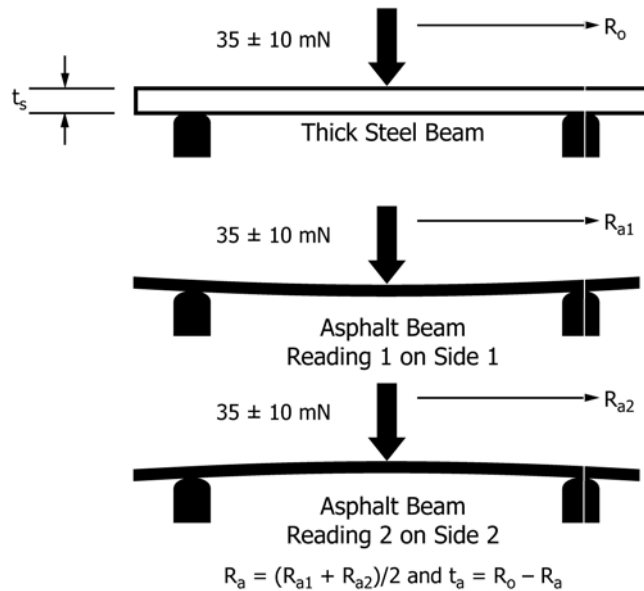

FIG. 8 Specimen Thickness Measured with Displacement Transducer

The 6.35-mm thick stainless steel beam (section 7.8.1) shall be used for checking the contact load and test load.

NOTE 17—Do not perform these checks with the thin steel beam or an asphalt test specimen.

13.3.1 Place the thick steel beam in position on the beam supports. Using the test load regulator valve, gently increase the force on the beam to  $980 \pm 50$  mN.

13.3.2 Switch from the test load to the contact load and adjust the force on the beam to  $35 \pm 10$  mN. Switch between the test load and contact load until consistent readings are obtained for the contact load and test load. Successive contact load readings that vary by no more than 10 mN shall be judged as consistent.

13.3.3 When switching between the test load and contact, observe the loading shaft and platform for visible vertical movement. The loading shaft shall maintain contact with the steel beam when switching between the contact load and test load and the contact load and test load shall be maintained at  $35 \pm 10$  mN and  $980 \pm 50$  mN, respectively.

13.3.4 *Corrective Action*—If the requirements of sections 13.3.1 – 13.3.3 are not met, the device may require calibration as per A1.2 or the loading shaft may be dirty or require alignment (see section 11.2). If the requirements of sections 13.3.1 – 13.3.3 cannot be met after calibration, cleaning, or other corrective action, discontinue use of the device and consult the equipment manufacturer.

13.4 Enter the specimen identification information, elapsed time the specimen is conditioned in bath at the test temperature, and other information as appropriate into the computer that controls the test system (see Table A1.1).

13.5 After conditioning, place the test specimen on the test supports and gently position the back side of the test specimen against the alignment pins. Initiate the test as described in section 13.6. The bath temperature shall be maintained at the test temperature  $\pm 0.1^\circ\text{C}$  during the test, otherwise, the test shall be rejected.

13.6 Manually apply a  $35 \pm 10$  mN contact load for no longer than 10 s to the test specimen to ensure contact between the test specimen and the loading head.

NOTE 18—The  $35 \pm 10$  mN contact load is required to ensure continuous contact between the loading shaft, end supports, and the test specimen. Failure to establish continuous contact within the required load range can give misleading results. Holding the contact for an excessive amount of time can affect the reported stiffness and m-values.

13.7 The contact load shall be applied in the following sequence: 1) adjust the two load regulators as described in 13.3.3; 2) lift the loading shaft manually, 3) place the test beam on the supports, and 4) lower the shaft manually to make contact with the test beam. When contact is made the indicated load must be  $35 \pm 10$  mN. If the load is not  $35 \pm 10$  mN, remove the beam and return to 13.3.3. While applying the contact load, the load on the beam shall not exceed 45 mN and no adjustment shall be made to the contact load once the beam is placed on the supports. The seating load shall be applied (test started) within 10 seconds after the shaft first contacts the beam.

NOTE 19—A block of plastic foam placed underneath the loading platform has been found convenient for elevating the shaft while the test beam is placed on its supports.

13.8 With the contact load applied to the test specimen, activate the automatic test system, which is programmed to proceed as follows:

13.8.1 Apply a  $980 \pm 50$  mN seating load for  $1 \pm 0.1$ s.

NOTE 20—The seating load described in sections 13.8.1, 13.8.2, and Fig. 2 is applied and removed automatically by the computer-controlled loading system and is transparent to the operator.

13.8.2 Reduce the load to the  $35 \pm 10$  mN contact load and allow the test specimen to recover for  $20 \pm 0.1$  s. At the end of the seating load, the operator shall monitor the computer screen to verify that the load on the test specimen returns to  $35 \pm 10$  mN. If it does not, the test shall be rejected.

13.8.3 Apply a  $980 \pm 50$  mN test load to the test specimen. The software shall record the test load at 0.5 s intervals from

0.5 s to 240 s and calculate the average of the recorded load values. Between 0.5 and 5 s, the test load shall be within  $\pm 50$  mN of the average test load and for the remaining times within  $\pm 10$  mN of the average test load. The actual load on the test specimen as measured by the load cell shall be used to calculate the stress in the test specimen. The loading pattern is defined in Fig. 2.

13.8.4 Remove the test load and return to the  $35 \pm 10$  mN contact load.

13.9 Remove the specimen from the supports and proceed to the next test.

## 14. Reduction of Test Data

14.1 The data acquisition software shall generate a plot of the measured load and the measured deflection of the test specimen versus loading time at intervals of 0.5 s or less, starting with application of the seating load. Deflection shall be in units of mm and load in units of mN. A typical representation of the loading and deflection curves is shown in Fig. 2.

14.2 Calculate the measured stiffness of the test specimen at loading times of 8.0, 15.0, 30.0, 60.0, 120.0 and 240.0 s from the dimensions of the test specimen, the measured test load, and the test specimen deflection using:

$$S_m(t) = PL^3/4bh^3\delta(t) \quad (3)$$

where:

- $S_m(t)$  = flexural creep stiffness at time t, MPa,
- $P$  = measured test load, mN,
- $L$  = span length, mm,
- $b$  = width of test specimen, mm,
- $h$  = depth of test specimen, mm, and
- $\delta(t)$  = deflection of test specimen at time t.

14.2.1 Do not use values of load and deflection obtained before 8 s loading time to calculate the stiffness. Data from a creep test obtained immediately after application of the test load may not be valid because of dynamic loading effects and the finite rise time of the applied load.

### 14.3 Calculation of $S$ and $m$ -Value:

14.3.1 Fit the logarithm of the stiffness values versus the logarithm of the loading times using a second degree polynomial by calculating:

$$\begin{aligned} A &= [S_y(S_{x2}S_{x4} - S_{x3}^2) + S_{yx1}(S_{x2}S_{x3} - S_{x1}S_{x4}) + S_{yx2}(S_{x1}S_{x3} - S_{x2}^2)]/D \\ B &= [S_y(S_{x2}S_{x3} - S_{x1}S_{x4}) + S_{yx1}(6S_{x4} - S_{x2}^2) + S_{yx2}(S_{x1}S_{x2} - 6S_{x3}^2)]/D \\ C &= [S_y(S_{x1}S_{x3} - S_{x2}^2) + S_{yx1}(S_{x1}S_{x2} - 6S_{x3}^2) + S_{yx2}(6S_{x2} - S_{x1}^2)]/D \\ D &= 6(S_{x2}S_{x4} - S_{x3}^2) + S_{x1}(S_{x2}S_{x3} - S_{x1}S_{x4}) + S_{x2}(S_{x1}S_{x3} - S_{x2}^2) \end{aligned}$$

where, for loading times of 8, 15, 30, 60, 120, and 240 s:

$$\begin{aligned} S_y &= \log S_m(8) + \log S_m(15) + \dots + \log S_m(240), \\ S_{x1} &= \log(8) + \log(15) + \dots + \log(240), \\ S_{x2} &= [\log(8)]^2 + [\log(15)]^2 + \dots + [\log(240)]^2, \\ S_{x3} &= [\log(8)]^3 + [\log(15)]^3 + \dots + [\log(240)]^3, \\ S_{x4} &= [\log(8)]^4 + [\log(15)]^4 + \dots + [\log(240)]^4, \\ S_{yx1} &= [\log S_m(8)][\log(8)] + [\log S_m(15)][\log(15)] + \dots + \\ &\quad [\log S_m(240)][\log(240)], \text{ and} \\ S_{yx2} &= [\log S_m(8)][\log(8)]^2 + [\log S_m(15)][\log(15)]^2 + \dots + \\ &\quad [\log S_m(240)][\log(240)]^2. \end{aligned}$$

14.3.2 Calculate the fraction of the variance in the stiffness explained by the quadratic model as:

$$R^2 = [6A S_y + 6B S_{yx1} + 6C S_{yx2} - S_y^2]/[6 S_{y2} - S_y^2] \quad (4)$$

where:

$$S_{y2} = [\log S(8)]^2 + [\log S(15)]^2 + \dots + [\log S(240)]^2$$

14.4 Calculate the estimated stiffness values at loading times of 8.0, 15.0, 30.0, 60.0, 120.0 and 240.0 seconds using:

$$\log S_e(t) = A + B[\log(t)] + C[\log(t)]^2 \quad (5)$$

where:

- $A$ ,  $B$ , and  $C$  = the regression coefficients determined in 14.3.1, and
- $t$  = loading time.

14.4.1 Estimated and measured values of the stiffness should agree within 2 %. Otherwise, the test results are suspect.

14.5 Estimate the  $m$ -value for loading times of 8.0, 15.0, 30.0, 60.0, 120.0 and 240.0 seconds using:

$$m(t) = |d\log[S(t)]/d\log(t)| = |[B + 2C\log(t)]| \quad (6)$$

where:

- $B$  and  $C$  = the regression coefficients determined in 14.3.1, and
- $t$  = loading time.

14.6 Calculate the average load during the test by averaging the loads at 0.5 s and every 0.5 s thereafter up to 240 s.

14.7 For the time period between 0.5 s and 5.0 s calculate the maximum difference between the average load and the recorded loads at each 0.5 s interval.

14.8 For the time period between 5.0 and 240 s, calculate the maximum difference between the average load and the recorded loads at each 0.5-s interval.

## 15. Report

15.1 The report shall contain but not be limited to the information listed below. A recommended test report format is given in Table A1.1.

NOTE 21—Report information which follows details the data that shall be generated by the BBR software. Actual communication of specific test result information by the user of this method to second parties is at the discretion of the user. Format of such communications is beyond the scope of this method.

### 15.2 Test Specimen Information:

15.2.1 BBR File name,

15.2.2 Test Specimen ID Number,

15.2.3 Test specimen width (default value is 12.70 mm),

15.2.4 Test specimen thickness (mm to nearest 0.01 mm).

Default value is 6.35 mm. Enter values only if determined as per Section 13.3.2 or 13.3.3.

15.2.5 Date of test (dd/mm/yy),

15.2.6 Operator's name, and

15.2.7 Version of software used.

### 15.3 Calibration Information:

15.3.1 Date of last temperature calibration (mm/dd/yy),

15.3.2 Date of last load cell calibration (mm/dd/yy),

15.3.3 Load cell calibration constants (mN/bit to three significant figures),

15.3.4 Date last LVDT calibration (mm/dd/yy),

15.3.5 LVDT calibration constants ( $\mu\text{m/bit}$  to three significant figures),

15.3.6 Date of last modulus check ( $\text{mm/dd/yy}$ ),

15.3.7 Measured modulus steel beam (GPa to three significant figures),

15.3.8 Date of last compliance check ( $\text{mm/dd/yy}$ ), and

15.3.9 Compliance of loading system ( $\mu\text{m/N}$  to three significant figures).

15.4 Test Conditions:

15.4.1 Time test load applied (h,m),

15.4.2 Maximum temperature during test ( $^{\circ}\text{C}$  to nearest  $0.1^{\circ}\text{C}$ ),

15.4.3 Minimum temperature during test ( $^{\circ}\text{C}$  to nearest  $0.1^{\circ}\text{C}$ ),

15.4.4 Maximum load recorded during test (mN to nearest 1 mN),

15.4.5 Minimum load recorded during test (mN to nearest 1 mN),

15.4.6 Contact load at  $t = 0$ , just prior to application of test load (mN to nearest 1 mN), and

15.4.7 Test load after 0.5 s loading time (mN to nearest 1 mN).

15.5 Test Results (Report the following test results for time intervals of 8.0, 15.0, 30.0, 60.0, 120.0, and 240.0 s):

15.5.1 Loading time in seconds (nearest 0.1 s),

15.5.2 Test load (mN to nearest 1 mN),

15.5.3 Test specimen deflection (mm to nearest 1  $\mu\text{m}$ ),

15.5.4 Measured Stiffness Modulus, Eq 3 (MPa to three significant figures),

15.5.5 Estimated Stiffness Modulus Eq 5 (MPa to three significant figures), and

15.5.6 Percent difference between estimated and measured stiffness shall be calculated as based on Eq 3 and Eq 5:

$$\left\{ \frac{(\text{Estimated} - \text{Measured}) \times 100\%}{\text{Measured}} \right\}$$

15.5.7 Estimated m-value, Eq 6 (to nearest 0.001).

15.6 For each test, report the following summary data as shown in Table A1.1.

15.6.1 Regression coefficients and  $R^2$  as per Eq 4 and Section 14.3.1,

15.6.2 Average load obtained by averaging the load at 0.5 s and every 0.5 s thereafter up to 240.0 s,

15.6.3 Maximum deviation of load from average load during interval from 0.5 to 5.0 s (mN),

15.6.4 Maximum deviation of load from average load during interval from 5.0 to 240.0 s (mN),

15.6.5 Deflection at zero time (mm), and

15.6.6 Deflection at 0.5 s (mm).

15.7 *Data File*—The software shall generate a data file in non-proprietary format containing the load cell readings, LVDT readings, and temperature readings in units of mN, mm, and  $0.1^{\circ}\text{C}$ . The readings shall start at zero time and continue for 240 s at 0.5 s intervals. The file shall be in comma separated text format. It shall not be a part of the report but shall be accessible at the option of the user.

## 16. Precision and Bias

16.1 *Precision*—Criteria for judging the acceptability of replicate measurements of flexural creep stiffness and m-value are given in Table 1. The criteria in Table 1 are based on several AMRL proficiency samples and several round robins involving more than 300 tests and different grades of binder.

16.2 *Single-Operator Precision (Repeatability)*—Duplicate results obtained by the same operator using the same equipment in the same laboratory shall not be considered suspect unless the difference in the duplicate results, expressed as a percent of their mean, exceeds the values given in Table 1 for single operator precision.

16.3 *Multi-laboratory Precision (Reproducibility)*—Two results submitted by two different operators testing the same material in different laboratories shall not be considered suspect unless the difference in the results, expressed as a percent of their mean, exceeds the values given in Table 1 for multi-laboratory precision.

16.4 *Bias*—Since there is no acceptable reference value the bias for this test method cannot be determined.

## 17. Keywords

17.1 bending beam rheometer; flexural creep compliance; flexural creep stiffness

**TABLE 1 Estimated Repeatability and Reproducibility**

Condition	Coefficient of Variation (1 s %) <sup>A</sup>	Acceptable Range of Two Test Results (d2s %) <sup>A</sup>
Single-Operator Precision		
Creep Stiffness (MPa)	3.2	9.1
Slope	1.4	4.0
Multi-laboratory Precision		
Creep Stiffness (MPa)	9.5	26.9
Slope	4.6	13.0

<sup>A</sup> These values represent the 1s % and d2s % limits described in Practice C670. These values are based on data from the AASHTO Materials Reference Laboratory Proficiency Testing Program and other regional round robin testing programs conducted with metal (aluminum) molds. Round robin testing conducted with metal and silicone rubber molds has shown that results obtained with the two different types of molds are not statistically different.

**ANNEX**
**(Mandatory Information)**
**A1. CALIBRATION**

Calibrate the components of the BBR as required by section 11.2 in accordance with the following instructions:

**A1.1 Calibration of Displacement Transducer**—Calibrate the displacement transducer using a stepped gage block of known dimensions similar to the one shown in Fig. 7. With the loading frame mounted in the bath at the test temperature, remove all beams from the supports and place the stepped gage block on a reference platform underneath the loading shaft according to the instructions supplied by the instrument manufacturer. Apply a 100-g mass on the loading shaft and follow the manufacturer’s instructions to obtain a displacement transducer reading on each step. The software provided by the manufacturer shall convert the measurements to a calibration constant in terms of  $\mu\text{m/bit}$  to three significant figures and shall automatically enter the new constant into the software. The calibration constant should be repeatable from one calibration to another, otherwise the operation of the system may be suspect.

**A1.2 Calibration of Load Cell**—Calibrate the load cell in accordance with the manufacturer’s instructions using a minimum of four masses evenly distributed over the range of the load cell. The software provided by the manufacturer shall convert the measurements to a calibration constant in terms of  $\text{mN/bit}$  to three significant figures and shall automatically enter the new constant into the software. The calibration constants should be repeatable from one calibration to another, otherwise the operation of the system may be suspect. Repeat the process for each test temperature.

**A1.3 Calibration of Internal Thermometric Device**—Calibrate the internal thermometric device by using a calibrated thermometric device of suitable range meeting the requirements of Section 7.9. Immerse the probe of the calibrated thermoelectric device (or bulb of the liquid-in-glass thermometer) in the liquid bath close to the probe of the DSR. Compare the temperature displayed by the calibrated thermometric device to the temperature displayed by the BBR. If the

**TABLE A1.1 Typical Test Report**

		Test Conditions	
File Name	AXX5M301#	Max temp during test (°C)	
Test Specimen ID No. <sup>A</sup>	AXB5PAV	Min. temp. during test (°C)	
Project ID No. <sup>A</sup>	XY DOT 45	Maximum Load during test (mN)	989
Operator’s Name <sup>A</sup>	Joe Smith	Minimum Load during test (mN)	994
Date of test (mm/dd/yy)	03/22/97	Date last temperature calib. (mm/dd/yy)	03/22/97
Specimen width (mm) <sup>B</sup>	12.70	Load calib. Constant (mN/bit)	2.40
Specimen thick (mm) <sup>B</sup>	6.35	Date last load cell calib. (mm/dd/yy)	03/22/97
Elapsed time in bath (m) <sup>A</sup>	63	LVDT calib. Constant ( $\mu\text{m/bit}$ )	2.54
Time test load applied (h,m)	14:37	Date last LVDT calib. (mm/dd/yy)	03/22/97
Manf./Model of BBR	BB Tech-01	Modulus steel beam (GPa)	200
Device ID <sup>A</sup>	Unit No. 2	Compliance of loading system ( $\mu\text{m/N}$ )	2.57
Software Version	V 6.7.1	Date of last compliance check (mm/dd/yy)	03/22/97

Two lines of 74 characters per line for software-generated or operator-entered warnings and comments.

<sup>A</sup> Entered by technician.

<sup>B</sup> Entered at option of technician. Remaining data entered automatically by software.

Test Results							
t Time (s)	P <sub>t</sub> Test Load (mN)	d Deflection (mm)	Measured Stiffness (MPa)	Estimated Stiffness (MPa)	Stiffness Difference (%)	m-value	
8.0	988	0.345	358	358	0.12	0.339	
16.0	987	0.401	287	287	-0.23	0.362	
30.0	987	0.482	222	222	0.10	0.387	
60.0	988	0.597	168	168	-0.03	0.411	
120.0	987	0.758	125	125	0.11	0.436	
240.0	989	0.992	91.7	91.8	0.07	0.461	
Calculated Parameters							
Regression Coefficients:(A, B, C, R <sup>2</sup> )		2.18	-0.195	0.00223	0.999981		
Contact load when t = 0.0 s (mN)		31					
Average load from 0.5 to 240 s		998	Test load when t = 0.5 s (mN)		1021		
Max. load deviation, 0.5 to 5.0 s (mN)		42	Max. load deviation, 5 to 240.0 s (mN)		2		
Deflection at zero time, (mm)		0.000	Deflection at 0.5 s (mm)		1.237		

temperature displayed by the BBR does not agree with the calibrated thermometric device within  $\pm 0.1^\circ\text{C}$ , follow the manufacturer's instructions for correcting the displayed BBR temperature to agree with the thermometric device temperature.

**A1.4 Determine the System Compliance**—Determine the system compliance in accordance with the manufacturer's instructions using a minimum of four masses evenly distributed over the range of the load cell. The data acquisition software

shall measure the position of the displacement transducer at each load. The compliance shall be calculated as the measured deflection per unit load. The software provided by the manufacturer shall convert the measurements to a compliance in terms of  $\mu\text{m}/\text{N}$  to three significant figures and shall automatically enter the compliance into the software. The compliance measurement may be performed as part of the load cell calibration or as a separate operation. The compliance measurement shall be performed each time the load cell is calibrated.

## APPENDIX

### (Nonmandatory Information)

#### X1. BEAM THEORY AND DATA INTERPRETATION

**X1.1 Deflection of an Elastic Beam**—Using elementary bending theory, the mid-span deflection of an elastic prismatic beam of constant cross-section loaded in three-point loading can be obtained by applying **Eq X1.1 and X1.2** as follows:

$$\delta = PL^3/48EI \quad (\text{X1.1})$$

where:

$\delta$  = deflection of beam at midspan, mm,  
 $P$  = load applied, N,  
 $L$  = span length, mm,  
 $E$  = modulus of elasticity, MPa, and  
 $I$  = moment of inertia,  $\text{mm}^4$ .

and,

$$I = bh^3/12 \quad (\text{X1.2})$$

where:

$b$  = width of beam, mm, and  
 $h$  = thickness of beam, mm.

**NOTE X1.1**—The test specimen has a span to depth ratio of 16 to 1, and the contribution of shear to deflection of the beam can be neglected.

**X1.2 Elastic Flexural Modulus**—According to elastic theory, calculate the flexural modulus of a prismatic beam of constant cross-section loaded at its midspan.

Therefore:

$$E = PL^3/4bh^3\delta \quad (\text{X1.3})$$

where:

$E$  = flexural creep stiffness, MPa,  
 $P$  = load, N,  
 $L$  = span length, mm,  
 $b$  = width of beam, mm,  
 $h$  = depth of beam, mm, and  
 $\delta$  = deflection of beam, mm.

**X1.3 Maximum Bending Stress**—The maximum bending stress occurs at the top and bottom of the beam at its midspan.

Therefore:

$$\sigma = 3PL/2bh^2 \quad (\text{X1.4})$$

where:

$\sigma$  = maximum bending stress in beam, MPa,  
 $P$  = constant load, N,  
 $L$  = span length, mm,  
 $b$  = width of beam, mm, and  
 $h$  = depth of beam, mm.

**X1.4 Maximum Bending Strain**—The maximum bending strain in the beam occurs at the top and bottom of the beam at its midspan.

Therefore:

$$\varepsilon = 6\delta h/L^2 \text{ mm/mm} \quad (\text{X1.5})$$

where:

$\varepsilon$  = maximum bending strain in beam, mm/mm,  
 $\delta$  = deflection of beam, mm,  
 $h$  = thickness of beam, mm, and  
 $L$  = span length, mm.

**X1.5 Linear Viscoelastic Stiffness Modulus**—According to the elastic-viscoelastic correspondence principle, it can be assumed that if a linear viscoelastic beam is subjected to a constant load applied at  $t = 0$  and held constant, the stress distribution in the beam is the same as that in a linear elastic beam under the same load. Further, the strains and displacements depend on time and are derived from those of the elastic case by replacing  $E$  with  $1/D(t)$ . Since  $1/D(t)$  is numerically equivalent to  $S(t)$ , rearranging the elastic solution results in the following relationship for the stiffness:

$$S(t) = PL^3/4bh^3\delta(t) \quad (\text{X1.6})$$

where:

$S(t)$  = time-dependent flexural creep stiffness, MPa,  
 $P$  = constant load, N,  
 $L$  = span length, mm,  
 $b$  = width of beam, mm,  
 $h$  = depth of beam, mm,  
 $\delta(t)$  = deflection of beam, at time  $t$ , mm, and

$\delta(t)$  and  $S(t)$  indicate that the deflection and stiffness, respectively are functions of time.

 **D6648 – 08 (2016)**

*ASTM International takes no position respecting the validity of any patent rights asserted in connection with any item mentioned in this standard. Users of this standard are expressly advised that determination of the validity of any such patent rights, and the risk of infringement of such rights, are entirely their own responsibility.*

*This standard is subject to revision at any time by the responsible technical committee and must be reviewed every five years and if not revised, either reapproved or withdrawn. Your comments are invited either for revision of this standard or for additional standards and should be addressed to ASTM International Headquarters. Your comments will receive careful consideration at a meeting of the responsible technical committee, which you may attend. If you feel that your comments have not received a fair hearing you should make your views known to the ASTM Committee on Standards, at the address shown below.*

*This standard is copyrighted by ASTM International, 100 Barr Harbor Drive, PO Box C700, West Conshohocken, PA 19428-2959, United States. Individual reprints (single or multiple copies) of this standard may be obtained by contacting ASTM at the above address or at 610-832-9585 (phone), 610-832-9555 (fax), or [service@astm.org](mailto:service@astm.org) (e-mail); or through the ASTM website ([www.astm.org](http://www.astm.org)). Permission rights to photocopy the standard may also be secured from the Copyright Clearance Center, 222 Rosewood Drive, Danvers, MA 01923, Tel: (978) 646-2600; <http://www.copyright.com/>*