



Standard Test Method for Tension Strength of Sew-Through Flange Buttons¹

This standard is issued under the fixed designation D6644; the number immediately following the designation indicates the year of original adoption or, in the case of revision, the year of last revision. A number in parentheses indicates the year of last reapproval. A superscript epsilon (ϵ) indicates an editorial change since the last revision or reapproval.

1. Scope

1.1 This test method measures the resistance of the bridge of a sew-through button to a steadily increasing strain.

1.2 The values stated in either SI units or inch-pound units are to be regarded separately as standard. The values stated in each system may not be exact equivalents; therefore, each system shall be used independently of the other. Combining values from the two systems may result in non-conformance with the standard.

1.3 *This standard does not purport to address all of the safety concerns, if any, associated with its use. It is the responsibility of the user of this standard to establish appropriate safety and health practices and determine the applicability of regulatory limitations prior to use.*

2. Referenced Documents

2.1 *ASTM Standards*:²
[D5497 Terminology Relating to Buttons](#) (Withdrawn 2011)³

3. Terminology

3.1 For button definitions, refer to Terminology [D5497](#).

4. Summary of Test Method

4.1 The sew-through flange button is sewn onto fabric and positioned in a clamping fixture. The combination is subjected to a strain recorded on a force gauge.

4.2 Tests are made on sew through flange buttons before laundering or dry cleaning with the option of testing again after a predetermined number of launderings or dry cleanings.

5. Significance and Use

5.1 This test measures an important property to users of sew through flange buttons. This is a means of determining the

resistance of the bridge of the button to a strain which can cause it to fall off a garment to which it is attached.

5.2 If there are differences of practical significance between the reported test results for two laboratories (or more), comparative tests should be performed to determine if there is a statistical bias between them, using competent statistical assistance. As a minimum, test samples should be used that are as homogeneous as possible, that are drawn from the material from which the disparate test results were obtained, and that are randomly assigned in equal numbers to each laboratory for testing. Other materials with established test values may be used for this purpose. The test results for the two laboratories should be compared using a statistical test for unpaired data, at a probability level chosen prior to the testing series. If a bias is found, either its cause must be found and corrected, or future test results must be adjusted in consideration of the known bias.

6. Apparatus

6.1 *Force Gauge*—One capable of measuring 20 kg (44 lb) of tension or compression with an accuracy of ± 0.1 kg (± 0.22 lb). The gauge may be hand held or specially mounted.

6.2 *Testing Machine*—A constant rate of extension (CRE) Tester shall be used. The capacity of the machine must be selected for the break position on the gauge to fall within 20-90 % of full scale.

6.3 *Jaw Clamping Fixture*—One capable of firmly holding the button, such as a long nose locking wrench or a 3-pronged clamping device.

6.4 *Commercial Sewing Machine*—One capable of automatically sewing the button to two or more layers of fabric.

7. Sampling

7.1 *Laboratory Sample*—Randomly select quantity of buttons, approximately 100-200, from the same carton and from boxes within that carton that adequately represent the material from which test specimens may be chosen.

7.2 *Test Specimens*—Randomly select 15-25 buttons from the laboratory sample for testing, if test specimens are submitted for preproduction approval, testing 15 buttons is acceptable.

¹ This test method is under the jurisdiction of ASTM Committee D13 on Textiles and is the direct responsibility of Subcommittee D13.54 on Subassemblies.

Current edition approved Jan. 1, 2013. Published February 2013. Originally approved in 2001. Last previous edition approved in 2007 as D6644-01(2007). DOI: 10.1520/D6644-01R13.

² For referenced ASTM standards, visit the ASTM website, www.astm.org, or contact ASTM Customer Service at service@astm.org. For *Annual Book of ASTM Standards* volume information, refer to the standard's Document Summary page on the ASTM website.

³ The last approved version of this historical standard is referenced on www.astm.org.

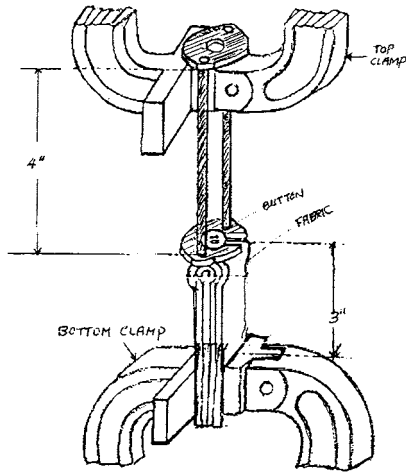

FIG. 1 Pull Testing Fixture

8. Conditioning

8.1 Condition the specimens as directed in practice D618 using procedure E. Following conditioning prepare the specimens as instructed in 9.4 of Practice D618. Preconditioning is not required.

9. Specimen Preparation

9.1 Sets, consisting of 5 buttons each, are prepared by attaching the buttons, at least 12.7 cm (5 in.) apart, with factory sewing equipment, to at least two layered production or development fabric processed to production finish.

NOTE 1—Suggested method is to use two layered cotton fabric, 12 threads per button with a minimum pull strength of the fabric and thread of 15 lb.

ASTM International takes no position respecting the validity of any patent rights asserted in connection with any item mentioned in this standard. Users of this standard are expressly advised that determination of the validity of any such patent rights, and the risk of infringement of such rights, are entirely their own responsibility.

This standard is subject to revision at any time by the responsible technical committee and must be reviewed every five years and if not revised, either reapproved or withdrawn. Your comments are invited either for revision of this standard or for additional standards and should be addressed to ASTM International Headquarters. Your comments will receive careful consideration at a meeting of the responsible technical committee, which you may attend. If you feel that your comments have not received a fair hearing you should make your views known to the ASTM Committee on Standards, at the address shown below.

This standard is copyrighted by ASTM International, 100 Barr Harbor Drive, PO Box C700, West Conshohocken, PA 19428-2959, United States. Individual reprints (single or multiple copies) of this standard may be obtained by contacting ASTM at the above address or at 610-832-9585 (phone), 610-832-9555 (fax), or service@astm.org (e-mail); or through the ASTM website (www.astm.org). Permission rights to photocopy the standard may also be secured from the ASTM website (www.astm.org/COPYRIGHT/).

10. Procedure

10.1 Select a set of buttons sewn onto fabric and position the clamping fixture underneath one of the buttons. Carefully position the attachment of the fixture so as not to affect the structural integrity of the button.

10.2 Position the clamped fixture into the “L” shaped hook of the force gauge or upper clamp of the commercial tester.

10.3 Place two ends of the fabric into the open jaws of the lower clamp with proper alignment

10.4 Activate the tester or pull down on the fabric until failure.

11. Report

11.1 State that the specimens were tested as directed in Test Method D6644.

11.2 Report the following information.

11.2.1 Force required to remove buttons from fabric (bridge of button breaks).

11.2.2 Report individual gauge readings and calculate average.

11.2.3 Report the failure mode (button failure, fabric failure, stitching failure).

12. Precision and Bias

12.1 *Precision*—The precision of this test has not been established.

12.2 *Bias*—No justifiable statement can be made on the bias of Test Method D6644 for Testing the Tension Strength of Sew Through Flange Buttons since the true values cannot be established by an accepted referee method.

13. Keywords

13.1 bridge of button; button failure