



# Standard Guide for Selection of Purging and Sampling Devices for Groundwater Monitoring Wells<sup>1</sup>

This standard is issued under the fixed designation D6634/D6634M; the number immediately following the designation indicates the year of original adoption or, in the case of revision, the year of last revision. A number in parentheses indicates the year of last reappraisal. A superscript epsilon ( $\epsilon$ ) indicates an editorial change since the last revision or reappraisal.

## 1. Scope\*

1.1 This guide describes the characteristics and operating principles of purging and sampling devices available for use in groundwater monitoring wells and provides criteria for selecting appropriate devices for specific applications. The selected device(s) should be capable of purging the well and providing valid representative samples of groundwater and included dissolved constituents. The scope does not include procedures for purging or collecting samples from monitoring wells, sampling devices for non-aqueous phase liquids, diffusion-type sampling devices or sampling from devices other than monitoring wells.

1.2 This guide reviews many of the most commonly used devices for purging and sampling groundwater monitoring wells. The practitioner should ensure that the purging and sampling methods used, whether or not they are addressed in this guide, are adequate to satisfy the monitoring objectives at each site.

1.3 This guide offers an organized collection of information or a series of options and does not recommend a specific course of action. This guide cannot replace education or experience and should be used in conjunction with professional judgment. Not all aspects of this guide may be applicable in all circumstances. This ASTM guide is not intended to represent or replace the standard of care by which the adequacy of a given professional service must be judged, nor should this document be applied without consideration of the many unique aspects of a project. The word “Standard” in the title of this document means only that the document has been approved through the ASTM consensus process.

1.4 The values stated in either SI units or inch-pound units are to be regarded separately as standard. The values stated in each system may not be exact equivalents; therefore, each system shall be used independently of the other. Combining

<sup>1</sup> This guide is under the jurisdiction of ASTM Committee D18 on Soil and Rock and is the direct responsibility of Subcommittee D18.21 on Groundwater and Vadose Zone Investigations.

Current edition approved Feb. 1, 2014. Published February 2014. Originally approved in 2001. Last previous edition approved in 2006 as D6634 – 01 (2006). DOI: 10.1520/D6634\_D6634M-14.

values from the two systems may result in non-conformance with the standard. Dimensions provided are typical.

1.5 *This standard does not purport to address all of the safety problems, if any, associated with its use. It is the responsibility of the user of this standard to establish appropriate safety and health practices and determine the applicability of regulatory limitations prior to use.*

## 2. Referenced Documents

### 2.1 ASTM Standards:<sup>2</sup>

D653 Terminology Relating to Soil, Rock, and Contained Fluids

D3740 Practice for Minimum Requirements for Agencies Engaged in Testing and/or Inspection of Soil and Rock as Used in Engineering Design and Construction

D5088 Practice for Decontamination of Field Equipment Used at Waste Sites

D6452 Guide for Purging Methods for Wells Used for Groundwater Quality Investigations

## 3. Terminology

3.1 *Definitions:* For definitions of general terms used within this guide, refer to Terminology D653.

## 4. Summary of Guide

4.1 The primary objective of groundwater sampling programs is to obtain samples that are representative of existing groundwater conditions retaining the physical and chemical properties of the groundwater in a specific water-bearing zone.<sup>3</sup> Depending on the purging and sampling protocol, this may require that the well is purged of stagnant water, or until

<sup>2</sup> For referenced ASTM standards, visit the ASTM website, www.astm.org, or contact ASTM Customer Service at service@astm.org. For *Annual Book of ASTM Standards* volume information, refer to the standard’s Document Summary page on the ASTM website.

<sup>3</sup> For example, the plasticizers in flexible PVC can contaminate samples with phthalate esters. The use of silicone rubber tubing, which contains no plasticizers, can obviate this problem; however, the potential for sample bias due to sorption/desorption exists with both materials (1). These pumps can be used with the intermediate vessel system described above, so that the sample contacts only the intake tubing and vessel avoiding contact with the pump mechanism tubing. Alternatively, using silicone rubber tubing at the pump head only can minimize this problem (2, 3).

\*A Summary of Changes section appears at the end of this standard

pre-determined purging criteria are met. Therefore, device(s) selected for use in groundwater sampling programs must be capable of purging the well as needed or delivering to the surface, or both, a sample representative of in-situ groundwater conditions. A number of factors can influence whether or not a particular sample or set of samples is representative, and one of the significant elements of sample collection protocols is the sampling mechanism (4, 5, 6).<sup>4</sup>

4.2 In selecting a purging or sampling device, or both, for use in a groundwater monitoring well, a number of factors must be considered. Among these are 1) outside diameter of the device; 2) materials from which the device and associated equipment are made; 3) overall impact of the device on groundwater sample integrity with respect to the analytes of interest; 4) ability to regulate the discharge rate of the device; 5) depth to water; 6) ease of operation and servicing; 7) reliability and durability of the device; 8) portability of the device and any needed accessory equipment, if applicable; 9) other operational limitations of the device; and 10) initial and operating cost of the device and accessory equipment. Based on these considerations, each of the devices available for purging or sampling groundwater, or both, from monitoring wells has its own unique set of advantages and limitations.

NOTE 1—The quality of the result produced by this guide is dependent on the competence of the personnel performing it, and the suitability of the equipment and facilities used. Agencies that meet the criteria of Practice D3740 are generally considered capable of competent and objective testing/sampling/inspection/etc. Users of this guide are cautioned that compliance with Practice D3740 does not in itself ensure reliable results. Reliable results depend on many factors; Practice D3740 provides a means of evaluating some of those factors.

## 5. Significance and Use

5.1 Appropriate purging and sampling equipment must be used to make sure that samples collected from monitoring wells represent the groundwater chemistry of the desired water bearing zone.

5.2 This guide is intended to be a common reference for purging and sampling devices. It can be applied to groundwater quality sampling from monitoring wells used for groundwater contamination evaluation, water supply characterization, and research.

5.3 This guide includes a number of general guidance statements that are not directly related to the operating principles or characteristics of the equipment. These statements are given to assist the user in understanding the application of the equipment, which could ultimately affect the selection process.

## 6. Apparatus

6.1 The apparatus described in this guide is commonly available from commercial suppliers.

## 7. Criteria for Selection of Purging and Sampling Devices

7.1 When selecting purging or sampling device(s), or both, a number of criteria must be evaluated as discussed below.

<sup>4</sup> The boldface numbers in parentheses refer to a list of references at the end of this standard.

Based on these criteria, each device has a unique set of advantages and limitations that define suitability to site-specific applications.

7.2 *Outside Diameter of the Device*—If the well(s) to be purged and sampled is (are) already in place, the initial consideration in selecting a device is whether or not the well(s) will accommodate the device. It is important to consider that the wells may not be plumb, may have constrictions in the casing (that is, at joints), or may contain other obstructions that make the effective inside diameter of the well smaller than the inside diameter of the casing. Alternately, if the monitoring wells are not in place, it may be more prudent to first select a device that meets the requirements of the sampling program and then select the size of the casing to be used in the wells. The smaller the inside diameter of the well, the more limited the selection of devices becomes. The majority of groundwater monitoring wells installed at various types of sites are small-diameter wells, or wells with inside diameters of 100 mm [4 in.] or less. All of the devices described herein will fit into a 100 mm [4 in.] inside diameter well, most can be installed in a 50 mm [2 in.] inside diameter well, and several can be used in wells of 19 mm [0.75 in.] inside diameter or less.

7.3 *Materials and Manufacture*—The choice of materials used in the construction of purging and sampling devices should be based upon knowledge of the geochemical environment and how the materials may interact with the sample via physical, chemical, or biological processes. Materials used in the manufacture of purging and sampling devices and associated tubing, hoses, pipes and support lines (for example, rope, cable or chain) may be a source of bias or error. Materials used should not sorb analytes from samples, desorb previously-sorbed analytes into samples, leach matrix components of the material that could affect analyte concentrations or cause artifacts, or be physically or chemically degraded due to water chemistry. Materials commonly used in the manufacture of sampling devices include rigid polyvinyl chloride (Type I PVC), stainless steel, polytetrafluorethylene (PTFE),<sup>5</sup> polyethylene (PE), polypropylene (PP), flexible polyvinyl chloride (Type II PVC), fluoroelastomers<sup>5</sup> polyvinylidene fluoride (PVDF), and Buna-N, ethylene-propylene diene monomer (EPDM) and silicone rubbers. Studies are available which indicate the relative sorption/desorption rates of these materials, their potential for alteration of the sample chemistry, and their ranking of desirability for use in sampling devices (4, 7, 8, 9, 1, 10). Extrusions and molded parts made of polymeric materials may contain surface traces of organic extrusion aids or mold release compounds. Also, some formulations of polymeric materials may contain fillers or processing additives that can leach from the material and alter sample quality. Traces of cutting oils, solvents or surface coatings may be present on metallic materials. These should be removed and, once removed, should not affect sample chemistry. It is generally preferable to use materials produced without the use

<sup>5</sup> PTFE is also commonly known by the trade name Teflon®, which includes other fluoropolymer formulations. Teflon is a registered trademark of E. I. DuPont de Nemours & Company. Fluoroelastomers (FPM, FKM) are commonly known by the trade name Viton®, a registered trademark of DuPont.

of these processing or surface coatings. Metallic materials are subject to corrosion; electropolishing or other surface passivation processes can improve corrosion resistance. Corrosion and residues from unfinished metallic materials could affect sample quality.

**7.4 Impact on Sample Integrity**—While it is not particularly important to preserve the chemical integrity of water purged from a monitoring well, the device(s) chosen for purging and sampling should be evaluated to make sure that they minimize physical or chemical alteration of the water in the well and the subsequent sample by their methods of delivering water to the surface. Because the subsurface environment is under different temperature, pressure, gas content, and redox potential conditions than those at the surface, precautions must be taken so that these conditions are preserved as much as possible as sample water is transported to the surface. Devices that introduce air or non-inert gas into a sample or that cause a sample to undergo significant temperature or pressure changes from the sampling depth to the surface are less desirable from the standpoint of preserving the chemical quality of the sample (5, 11). For example, systems that allow air to contact the sample could cause oxidation of the samples, which can have a significant impact on both organic and inorganic chemical constituents (5, 11, 12). In general, the rate at which a sampling device is operated could affect sample quality, with higher rates having greater effect. Turbulence and depressurization could result in significant changes in dissolved oxygen, carbon dioxide, dissolved metals and volatile organic compounds (VOCs) in a sample (4, 5). Inserting a device into the water column, withdrawing the device, and the rate at which water is removed from a well can often affect sample turbidity (13, 14). This can impact concentrations of some analytes or interfere with some analytical determinations (15).

**7.5 Water Removal Rate and Flow Rate Control**—Consideration should be given to appropriate water removal rates when selecting purging and sampling devices. For example, samples collected for analysis of some sensitive parameters (that is, VOCs and trace metals) should be taken at low flow rates. Sampling rates should be high enough to fill sample containers efficiently but low enough to minimize sample alteration. Additionally, the use of low flow rate purging techniques may require adjusting the pumping rate to account for the hydraulic performance of the well. Therefore, it is generally desirable to have the ability to control the flow rate of a purging or sampling device. Throttling down the device using a valve in the discharge line reduces the flow rate, but creates a pressure drop across the valve, and does not necessarily reduce the speed of the device in the well. Another method of reducing flow rate is to divert a portion of the discharge stream.

**7.6 Depth to Water and Lift Capability**—The greater the depth to water, the more pumping head the device must overcome to deliver water to the surface. Thus, the pumping lift capability of the device determines whether or not the device is suitable for individual applications. In addition, the greater the depth to water, the more time-consuming the purging and sampling operation becomes. Generally, the selec-

tion of available purging and sampling devices is more limited with increased depth to water.

**7.7 Operation and Servicing**—Ease of operation and servicing are important but frequently overlooked considerations in the selection of purging and sampling devices. A common source of poor precision in sampling results is sampling device operating problems (16). This could be due to any one of several factors either: 1) the device and accessory equipment are too complicated to operate efficiently under field conditions; 2) the operator is not familiar enough with the device to operate it properly; or 3) the operating manual supplied with the device does not clearly outline the procedures for proper use. Thus, it is not only important to select a device that is simple to operate, but also to provide proper training for the operator(s) of the device. Since mechanical devices are subject to malfunction or failure, it may be desirable to service the device in the field or have a replacement device available. Some of the devices described herein may be too complex for field repairs, requiring servicing by the manufacturer or a qualified service facility.

**7.8 Reliability and Durability**—Reliability and durability are two additional factors related to maintenance that warrant attention. Devices used in some monitoring programs must be capable of operating for extended periods of time in subsurface environments containing a variety of chemical constituents that may cause corrosion of metallic parts or degradation of plastic materials (9). This is especially true where devices are dedicated to wells and thus are continually exposed to potentially aggressive chemical environments.

**7.9 Portability vs. Dedication**—In practice, purging and sampling devices are employed in one of two modes: portable (used in multiple wells) or dedicated (installed for use in a single well). Dedicating sampling equipment eliminates the need to decontaminate this equipment after each use, and can eliminate the potential for cross-contamination of wells and samples and possible contamination from handling or improper storage of portable equipment. Dedicated equipment can also be more cost effective to use in routine monitoring programs due to reduced field labor and the elimination of the cost of decontamination and analytical blanks. Portable equipment must be cleaned between use in each monitoring well or discarded after use to avoid cross-contamination of wells and samples. In addition, the components must withstand the necessary cleaning processes. Some devices, by virtue of their design, may be difficult to disassemble to clean. It may be more practical to clean these devices by circulating cleaning solutions and rinses through the device and any associated tubing, hose or pipe in accordance with Practices D5088, or to replace the associated tubing, hose or pipe. Field decontamination operations can be difficult due to the need for sufficient decontamination supplies, exposure of the equipment to potential contaminants, and the handling and disposal of the decontamination waste water and supplies. Where field decontamination is not practical or possible, it may be simpler to use dedicated devices or take a number of portable sampling devices into the field and decontaminate them later at a more



appropriate location. Following any cleaning procedure, equipment blanks should be collected to assess the effectiveness of the cleaning procedure.

7.9.1 The remote location of some monitoring wells or rough terrain may require that the sampling device and accessory equipment selected (that is, tubing or tubing bundles, hose reels, battery packs, generators, compressed air source, controlling devices, decontamination equipment and supplies, purge water containers, etc.) be highly portable. While some devices can be hand-carried to remote sites, some manufacturers have mounted their equipment on backpack frames, small wheeled carts and specialized vehicles in an effort to improve portability. Other equipment is too bulky and heavy to be transported in the field without being vehicle-mounted.

7.10 *Other Operational Characteristics*—Operational characteristics such as solids handling capability, ability to run dry, cooling requirements, and intermittent discharge must be considered in the application of some purging and sampling devices. Some devices may experience increased wear or damage as solids pass through the device causing reduced output or failure. Solids may also clog check valves or passages, or both, which can reduce discharge rate or, in the case of grab samplers, cause the retained sample to leak out.

7.10.1 Running dry can occur when water level in the well is drawn down below the pump intake. In some pump designs, typically those with rotating or reciprocating mechanisms, this can cause damage to or failure of the device.

7.10.2 Some purging/sampling devices may alter the temperature of the surrounding groundwater. For some devices, this heat exchange prevents the device from overheating and possible damage or failure. The resultant change in water temperature could alter sample chemistry in a number of ways. Heating water reduces the solubility of dissolved gasses in water. The resultant loss of dissolved CO<sub>2</sub> and O<sub>2</sub> can induce a shift in pH and possibly in redox state, which then causes precipitation of carbonates (calcium, magnesium) and dissolved metals, most readily iron. The precipitation of iron can then cause co-precipitation of other metals such as nickel, copper, and chromium. Heating will also reduce the solubility of VOCs in water, resulting in greater volatilization. (5, 11).

7.10.3 Intermittent discharge from some purging and sampling devices must be considered when measuring indicator parameters with in-line monitoring devices or performing in-line filtration. Indicator parameters should be measured during pump discharge cycles. When filtering, care should be taken to prevent air from entering the filter during pump refill cycles.

7.11 *Cost*—Both the initial capital cost and the operating cost (including maintenance cost) of the sampling device and accessory equipment are important considerations. However, cost considerations should not result in the selection of devices that compromise data quality objectives. Proper selection and use of purging and sampling devices will more than pay for the capital and operational costs by providing proper collection of samples, resulting in cost savings from fewer false positive analytical results, resampling costs, investigations, and problems with regulatory or scientific goals and objectives.

NOTE 2—Consideration should be given that the device or devices

chosen for purging or sampling groundwater, or both, be used on a consistent basis in the future for a given sampling location. Some devices may have a greater variability than others (for example, the use of bailers). The more consistent the sampling methodology, the less sampling variability will be introduced for chemical and other results. If changes are made in the purging or sampling equipment or methodology, the users of the data should be informed that there may be differences in the results from the analysis. This is not to infer that any changes that may have an effect on sample data are to be avoided, but an evaluation of the results is recommended.

## 8. Purging and Sampling Devices

8.1 A wide variety of purging and sampling equipment is available for use in groundwater monitoring wells and boreholes. Available devices can be classified into four general categories: grab mechanisms (including bailers, syringe and thief samplers), suction-lift mechanisms (including surface centrifugal and peristaltic pumps), centrifugal submersible pumps, positive displacement mechanisms, (including gas displacement pumps, bladder pumps, piston pumps, progressive cavity pumps and gear pumps) and inertial lift pumps. Though frequently used in the groundwater industry for well development, the gas-lift method is generally considered unsuitable for purging and sampling because the extensive mixing of drive gas and water is likely to strip dissolved gasses from the groundwater and alter the concentration of other dissolved constituents (17). This method is not discussed for this reason.

8.2 Each of the purging and sampling devices described herein has specific operational characteristics that, in part, determine the suitability of each device for specific applications. These operational characteristics are listed in Tables 1 and 2, which summarize information derived from manufacturers' specifications for the various devices.

### 8.3 *Grab Sampling Devices:*

8.3.1 Bailers, syringe and thief samplers (for example, messenger samplers) are examples of grab sampling devices. These devices are lowered into the well bore on a cable, rope, chain or tubing to the desired sampling depth and then retrieved for purge water discharge, sample transfer or direct transport of the device to the laboratory for sample transfer and analysis.

8.3.1.1 The most commonly used grab samplers are bailers, in single check valve and dual check valve designs. A schematic of these two designs is illustrated in Fig. 1. Bailers are typically constructed of stainless steel, various plastics (for example, PVC and PE, and fluorocarbon materials).

8.3.1.2 The single check valve bailer is lowered into the well and water entering the bailer opens the check valve and fills the bailer. Upon retrieval, the weight of the check valve and water inside the bailer closes the check valve as the bailer exits the water column. The water in the bailer is retained from the greatest depth to which the bailer was lowered. There is some potential for the contents of the bailer to mix with the surrounding water column during retrieval, depending on the design of the bailer top.

**TABLE 1 Operational Characteristics of Purging and Sampling Devices (SI Units)**

Device	Type	Approximate Minimum Well Diameter (mm)	Maximum Lift (m)	Maximum Design Flow Rate (lpm)	Typical Flow Rate @ Maximum Lift (lpm)	Minimum Achievable Flow Rate (Discharge) (lpm)	Power Source
Bailer	GS	19	No Limit	Highly Variable	Highly Variable	<0.1	Manual or Mechanical
Messenger	GS	38.0	No Limit	Highly Variable	Highly Variable	<0.1	Manual or Mechanical
Syringe	GS	38.0	No Limit	1.0 litre <sup>A</sup>	1.0 litre <sup>A</sup>	<0.1	Pneumatic
Centrifugal Pump	CP	25.0	7.6	115 to 150	Highly Variable	Same as Max.	IC Engine or Electric
Peristaltic Pump	SL	12.0	8.8	45.0	0.4	<0.1	Electric
Centrifugal Submersible Pump	CP	50.0	80	34.0	2.0	<0.1	Electric
		100	520	322	4.5	<0.1	Electric
Gas Displacement Pump	PD	19	75.0	34.0	4.0	<0.1	Pneumatic
Bladder Pump	PD	19	305	13.0	0.4	<0.1	Pneumatic
Single-Acting Piston Pump	PD	50.0	125	19.0	17.0	<0.1	Pneumatic/Mechanical
Dual-Acting Piston Pump	PD	38.0	305	7.5	1.5	<0.1	Pneumatic
Progressive Cavity Submersible Pump	PD	50.0	55.0	4.5	1.0	<0.1	Electric
Gear Submersible Pump	PD	50.0	40.0	5.3	0.4	<0.1	Electric
		76.0	5.0	6.4	0.4	<0.1	Electric
Inertial Lift Pump	IL	19.0	80.0	15.0	15.0	<0.1	Manual, Electric or IC Engine

GS = Grab Sampler  
 CP = Centrifugal Pump  
 SL = Suction Lift Pump  
 PD = Positive Displacement Pump  
 IL = Inertial Lift Pump  
 IC Engine = Internal Combustion Engine

<sup>A</sup> Not a flow rate. This is the maximum capacity of the device.

**TABLE 2 Operational Characteristics of Purging and Sampling Devices (Inch-Pound Units)**

Device	Type	Approximate Minimum Well Diameter (in.)	Maximum Lift (ft)	Maximum Design Flow Rate (gpm)	Typical Flow Rate @ Maximum Lift (gpm)	Minimum Achievable Flow Rate (Discharge) Rate (gpm)	Power Source
Bailer	GS	0.75	No Limit	Highly Variable	Highly Variable	<0.026	Manual or Mechanical
Messenger	GS	1.5	No Limit	Highly Variable	Highly Variable	<0.026	Manual or Mechanical
Syringe	GS	1.5	No Limit	0.26 gal <sup>A</sup>	0.26 gal <sup>A</sup>	<0.026	Pneumatic
Centrifugal Pump	CP	1.0	25.0	30.0 to 40.0	Highly Variable	Same as Max.	IC Engine or Electric
Peristaltic Pump	SL	0.5	29.0	12.0	0.1	<0.026	Electric
Centrifugal Submersible Pump	CP	2.0	270	9.0	0.5	<0.026	Electric
		4.0	1700	85.0	1.2	<0.026	Electric
Gas Displacement Pump	PD	0.75	250	9.0	1.0	<0.026	Pneumatic
Bladder Pump	PD	0.75	1000	3.5	0.1	<0.026	Pneumatic
Single-Acting Piston Pump	PD	2.0	400	5.0	4.5	<0.026	Pneumatic/Mechanical
Dual-Acting Piston Pump	PD	1.5	1000	2.0	0.4	<0.026	Pneumatic
Progressive Cavity Submersible Pump	PD	2.0	180	1.2	0.3	<0.026	Electric
Gear Submersible Pump	PD	2.0	125	1.4	0.1	<0.026	Electric
		3.0	175	1.7	0.1	<0.026	Electric
Inertial Lift Pump	IL	0.75	260	4.0	4.0	<0.026	Manual, Electric or IC Engine

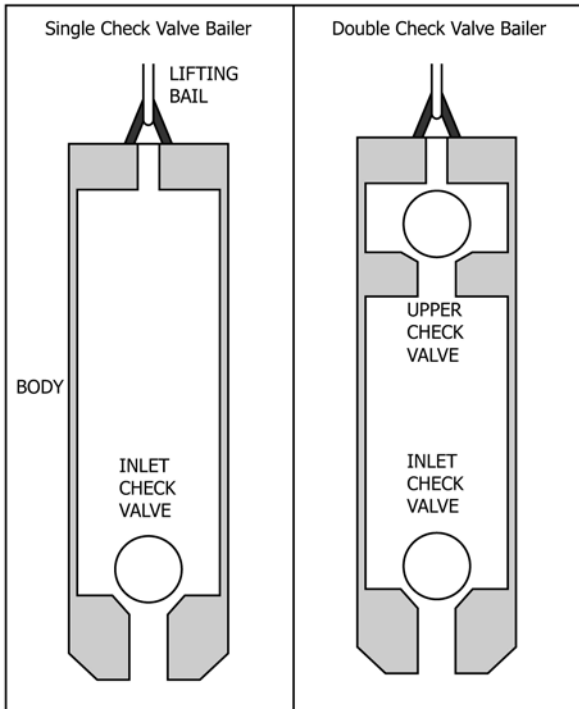
GS = Grab Sampler  
 CP = Centrifugal Pump  
 SL = Suction Lift Pump  
 PD = Positive Displacement Pump  
 IL = Inertial Lift Pump

<sup>A</sup> Not a flow rate. This is the maximum capacity of the device.

8.3.1.3 A dual check valve bailer is intended to prevent mixing of the sample with the water column upon retrieval. Water passes through the bailer as it is lowered. Upon retrieval, both check valves seat, retaining the aliquot of water inside the bailer.

8.3.1.4 In the case of both single and dual check valve bailers, the sample water is decanted into a sample container following retrieval of the bailer. A bottom discharge device with flow control may be used to provide improved control over the discharge of water from the bailer into the sample

**Example Of Single And Dual Check-Valve Bailers  
(Cross Section)**



**FIG. 1 Example of Single and Dual Check-Valve Bailers**

valve bailer unless the design allows for release of the upper check valve during use.

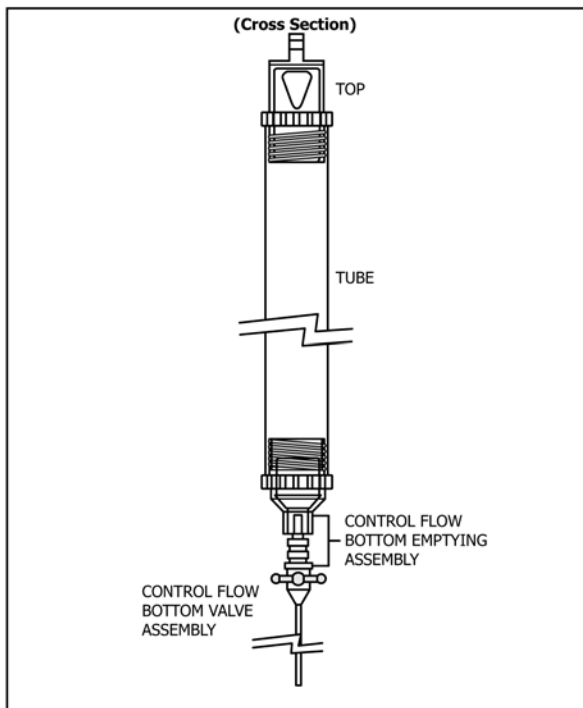
8.3.1.5 Another type of grab sampler called a thief sampler employs a mechanical, electrical or pneumatic trigger to actuate plugs or valves at either end of an open tube to open or close the chamber, or both, after lowering it to the desired sampling depth, thus sampling from a discrete interval within the well. Fig. 3 is an example of this type of sampler.

8.3.1.6 The syringe sampler illustrated in Fig. 4 is divided into two chambers by a moveable piston or float. The upper chamber is attached to a flexible air line that extends to the ground surface. The lower chamber is the sample chamber. The device is lowered into the well, and activated by applying a suction to the upper chamber, thereby drawing the piston or float upward and allowing water to enter the lower chamber. In situations where the pressure exerted on the lower chamber by submergence is great enough to cause the piston or float to move upward prior to achieving the desired sampling depth, the upper chamber can be pressurized to prevent piston movement. The device is then activated by slowly releasing the pressure from the upper chamber, allowing water to fill the lower chamber.

8.3.2 Samples collected with grab samplers, especially various types of bailers, exhibit variable accuracy and precision in sample chemistry, often due to operator technique (15, 16, 18, 19, 20). Grab samplers can aerate or agitate, or both, a sample, causing sample oxidation, degassing and stripping of VOCs from the sample. Care should be taken to avoid sample agitation during transfer of the sample from a grab sampler to the sample container. Pouring water from the top of a bailer either directly into the sample container or to a transfer vessel

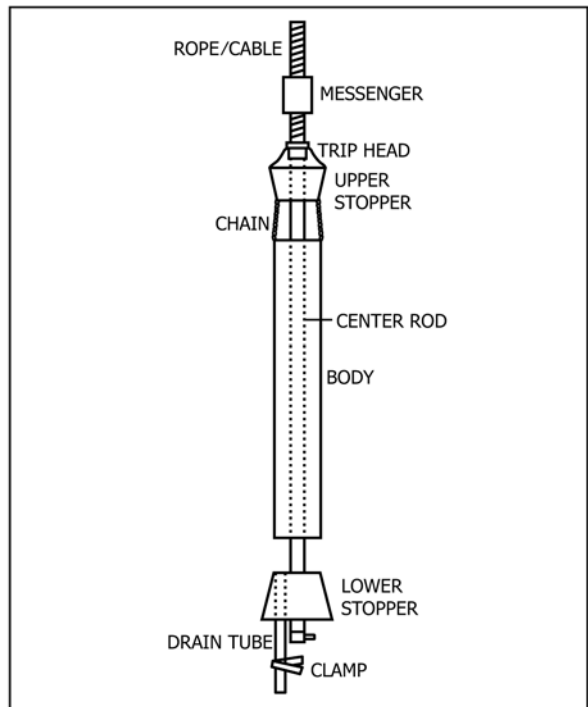
container. Fig. 2 illustrates an example of this type of device. A bottom discharge device may not work with a dual check

**Example Of Single Check-Valve Bailer With Bottom Discharge Device**

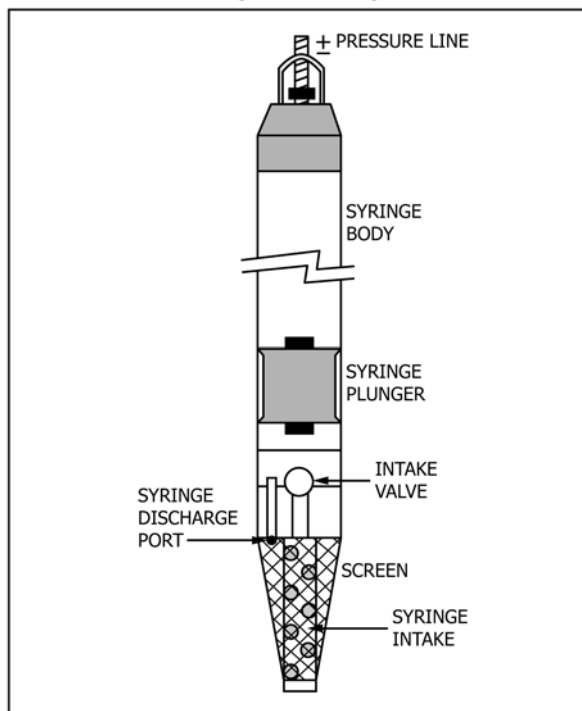


**FIG. 2 Example of Single Check-Valve Bailer with Bottom Discharge Device**

**Example Of A Grab Sampler (Kemmerer Type)  
(Cross Section)**



**FIG. 3 Example of a Grab Sampler (Kemmerer Type)**

**Example Of Grab Sampler (Syringe Type)  
(Cross Section)**

**FIG. 4 Example of Grab Sampler (Syringe Type)**

may agitate/aerate the sample and cause alteration of sample chemistry. These devices can also increase the turbidity of a sample and the potential for mixing with stagnant water through the surging action created in the well as the device moves through the water column. Grab samplers generally do not subject the sample to pressure changes, though some change may be imparted to a sample when using a syringe sampler activated with a suction. A potential for sample contamination exists due to exposure of the grab sampling device to the surface environment during repeated removal and reinsertion of the device during use. Also, the suspension cord or cable used with grab samplers could contribute contaminants to groundwater samples (21).

8.3.3 Grab sampling devices are generally not limited to a maximum sampling depth, though use in very deep wells may be impractical. Because grab samplers can be manufactured in very small diameters, they are usually not limited in use to a particular diameter of well casing. The rate at which water can be removed with a grab sampler will depend on the volumetric capacity of the device and the time required for lowering, filling, and retrieval. Generally, single check valve bailers are the only type of grab sampler practical for well purging; however, it may be impractical to use bailers to purge large quantities of water.

8.3.4 Some grab samplers are prone to malfunction or damage by sediment in the well. Operational difficulty may be experienced in sandy/silty water due to check valve or seal leakage. When used portably, the ability to clean or decontaminate a grab sampler between wells will vary depending upon design. Bailers are generally easier to clean than other types of grab sampling devices.

**8.4 Suction-Lift Pumps:**

8.4.1 Surface centrifugal and peristaltic pumps are two common suction-lift pumps. These pumps, typically located at or above ground level, draw water to the surface by applying suction to an intake line through the use of impellers or rotors driven by an electric motor or an engine. Surface centrifugal pumps use impellers that are typically constructed of metal (brass or mild steel), plastic, or synthetic rubber. Fig. 5A shows a representative design for this type of pump. A peristaltic pump (Fig. 5B) consists of a rotor with ball-bearing rollers that squeeze flexible tubing as they revolve within a stator housing. This action generates a reduced pressure at one end of the tubing and an increased pressure at the other end. Several types of elastomeric material can be used for the tubing, although flexible PVC and silicone rubber are most common.

8.4.1.1 One method of collecting a sample by suction consists of lowering one end of a length of tubing into a well and connecting the opposite end of the tubing to an intermediate vessel to which a suction is applied using a suction (vacuum) pump (Fig. 6). A sample can then be drawn directly into the intermediate vessel without contacting the pump mechanism.

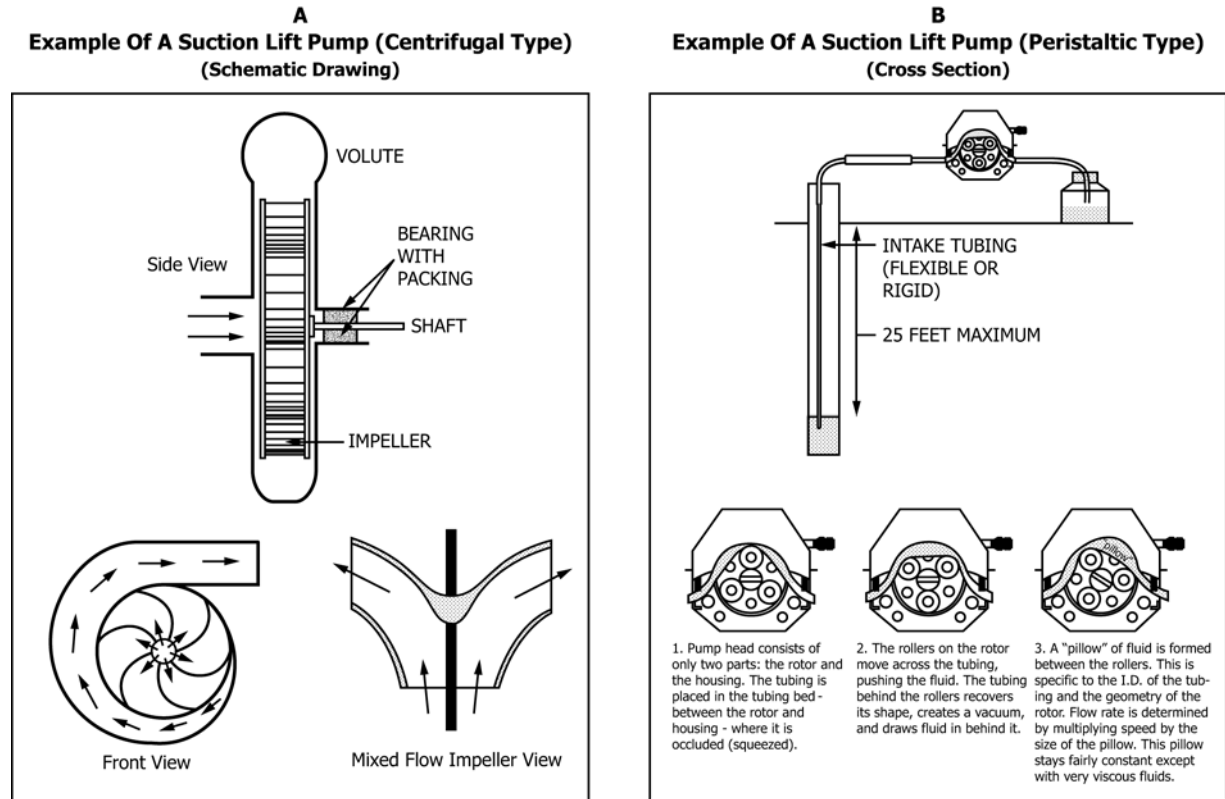
8.4.2 Suction lift pumps may be unacceptable for some groundwater sampling applications. Exertion of a reduced pressure on the sample can cause volatilization or may result in degassing which can cause changes in the pH, oxidation-reduction potential (ORP), and other gas-sensitive parameters (16, 2). Peristaltic pumps may be satisfactory for some analytes that are not affected by changes in the sample that can be caused by application of reduced pressure when used under low flow rate and low lift conditions (16, 22, 23).

8.4.2.1 Because surface centrifugal pumps can cause cavitation, they may not be appropriate for collection of samples to be analyzed for VOCs or gas-sensitive parameters such as trace metals. Because the pumped water contacts the pump mechanism, artifacts from sample contact with these materials should be considered when evaluating these pumps for sampling. In addition, these pumps can mix air from small leaks in the suction circuit into a sample, which can cause sample bias. These pumps may be difficult to adequately decontaminate between uses. To avoid the limitations posed by the effects of pumping or undesirable pump materials, an intermediate vessel could be used on the suction side of the pump circuit (Fig. 6).

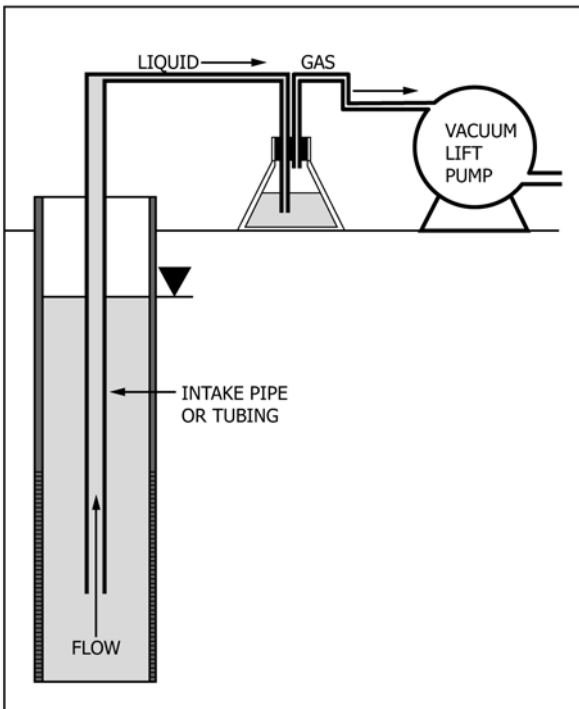
8.4.2.2 Peristaltic pumps do not usually cause cavitation, but as in all suction-lift pumps the exertion of a reduced pressure on the sample can bias the sample. The flexible tubing required for use in a peristaltic pump mechanism may cause sample bias.

NOTE 3—Water that remains in a monitoring well for a period of time may not be representative of formation water due to physical, chemical or biological changes that may occur as the water remains in contact with the well casing, dedicated sampling equipment and the air space in the upper casing. In addition, this stagnant water may not represent formation water at the time of sampling due to temporal changes in the groundwater chemistry in the water-bearing zone, whereas water within the well intake may be representative of formation water chemistry due to natural movement of groundwater through the intake zone. Water within the well intake zone may be representative of formation water chemistry due to natural movement of groundwater through the intake zone. To make sure





**Example Of A Suction Lift Pump (Vacuum Type) (Schematic Drawing)**



**FIG. 6 Example of a Suction Lift Pump (Vacuum Type)**

accomplished using packers located above the well screen, or through the use of low flow rate purging techniques (13, 14); removal can be accomplished using any of the devices described in the standard. Purging practices are described in greater detail in Guide D6452.

8.4.3 In theory, suction-lift pumps are limited to lifting water approximately 10.4 m [34 ft], depending on altitude and barometric pressure. In practice, a lift of 4.6 to 7.6 m [15 to 25 ft] is the typical upper limit. The diameter of wells to which these devices are applicable is limited only by the size of the intake tubing used. Sediment has only a minor effect on suction lift pumps, though large solids may plug the pump intake line.

8.4.4 Surface centrifugal pumps can pump at rates of 7 to 150 lpm [2 to 40 gpm] with 20 to 60 lpm [5 to 15 gpm] being more typical. Peristaltic pumps operate at rates of less than 0.004 lpm [0.001 gpm] to over 45 lpm [12 gpm].

**8.5 Centrifugal Submersible Pumps:**

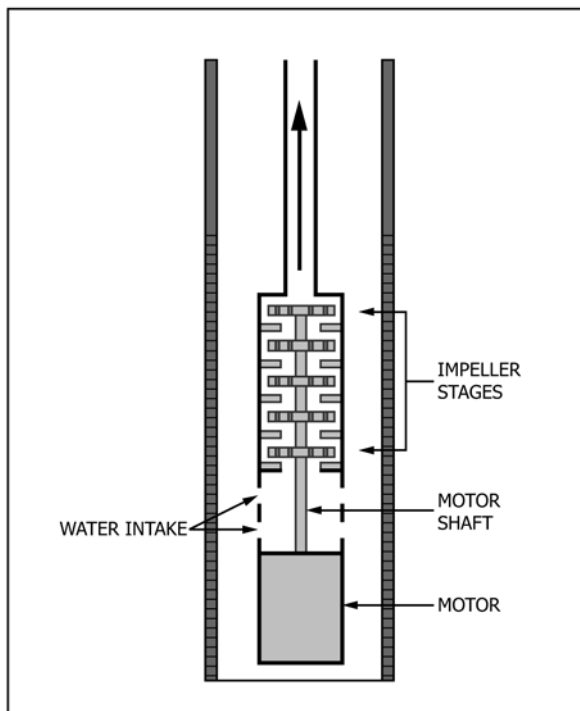
8.5.1 A centrifugal submersible pump (CSP) consists of impellers housed within diffuser chambers that are attached to a sealed electric motor, which drives the impellers through a shaft and seal arrangement. Water enters the CSP by pressure of submergence, is pressurized by centrifugal force generated by the impellers, and discharged to the surface through tubing, hose, or pipe. A CSP is suspended in a well by its discharge line or a support line, or both. Electric power is supplied to the motor through a braided or flat multiple-conductor insulated cable. Fig. 7 is a diagram of a CSP. CSPs are available in both fixed-speed and variable-speed configurations.

8.5.1.1 CSPs are driven by electric submersible motors. Most designs require that water continually pass over the motor to cool it, while some designs can cool sufficiently by free

that samples collected from a monitoring well are representative of formation water, all stored water must be either removed or isolated from the sampling zone within the well prior to sampling (7). Isolation can be



**Example Of A Electric Submersible Pump  
(Centrifugal Type-Schematic Drawing)**



**FIG. 7 Example of an Electric Submersible Pump**

convection in applications up to 30°C [86°F] provided that the pump motor is installed above the well intake zone. For designs that require flow for cooling, manufacturers of these pumps typically specify a minimum flow rate and velocity over the motor to prevent overheating. If the pump is located within the screen zone of the well or the well casing diameter is too large to provide sufficient flow over the motor, the use of a shroud may be required to achieve the necessary flow rate and velocity.

8.5.1.2 Flow rate and depth capability for designs is wide ranging (see [Tables 1 and 2](#)). For fixed-speed CSPs, flow rate is typically controlled through the use of a flow restrictor device, such as a gate valve or reducing orifice, in the discharge line. For variable-speed CSPs, the discharge rate can be reduced by regulating the frequency of the electrical power supply, controlling the motor speed to reduce flow rate.

8.5.2 Fixed-speed CSPs are considered to be acceptable for sampling a variety of groundwater parameters, including conductivity, major ions, and radioactive constituents ([24](#)). Studies comparing fixed-speed CSPs with other sampling devices have found that these pumps produce samples comparable to those from centrifugal and peristaltic suction-lift pumps, piston pumps, and progressive-cavity pumps for several VOCs ([25, 26](#)). While there is no available peer-reviewed literature addressing the sampling effects of small-diameter variable-speed CSPs on VOCs, one study found these pumps produced samples for some dissolved metals that were comparable to samples from bladder pumps ([27](#)). Heat generated by the CSP motor could increase sample temperature. For fixed-speed CSPs, the use of a flow restrictor to control the flow rate for sampling can create a pressure drop across the

restrictor, which could cause sample degassing and loss of VOCs. In lieu of this, a portion of the discharge stream can be diverted to reduce the discharge rate for sampling ([25](#)).

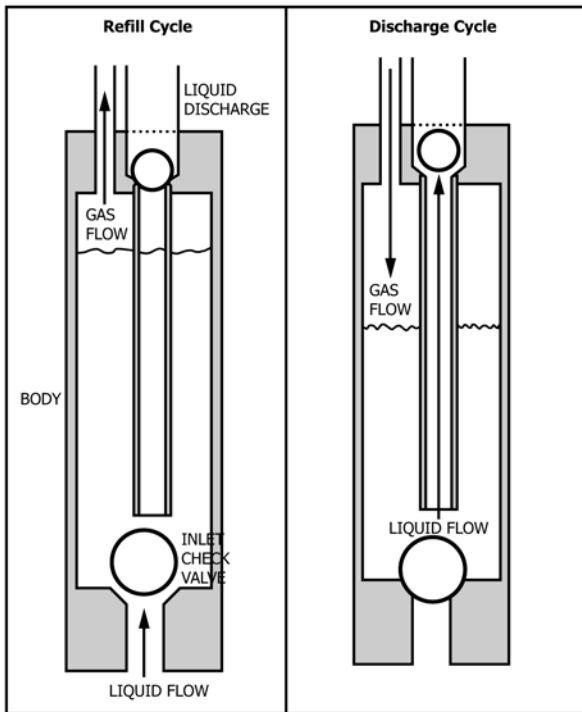
8.5.3 CSPs may be damaged when used in wells containing silty or sandy water, requiring repair or replacement of pump components or motor, or both. If overheating occurs, there are three possible consequences. First, where the motor has internal water or oil in it for improved cooling characteristics, some of this liquid may be released into the well, which could potentially contaminate the well or samples. Because of this, motors that contain oil should not be used if the oil could interfere with the analytes of interest. Further, water used in motors should be of known chemistry. Second, when this type of motor eventually cools, it can draw in water from the well, which could cause future cross-contamination problems. Proper decontamination of the pump should include changing internal cooling fluid if the pump is to be used in non-dedicated applications. As an alternative, dry sealed motors can be used to avoid these potential problems. Third, extensive or long-term overheating problems may result in motor failure, usually requiring replacement of the motor. CSPs should not be allowed to operate dry, or damage may occur to the pump seals or motor, or both. Some CSP designs may be difficult to disassemble in the field for cleaning or repair. For these pumps, if used portably, cleaning is usually performed by flushing the pump and discharge line and washing the exterior surfaces in accordance with Practices [D5088](#).

**8.6 Gas-Displacement Pumps:**

8.6.1 Gas-displacement or gas-drive pumps are distinguished from gas-lift pumps by the method of water transport. A gas displacement pump forces a discrete column of water to the surface via pressure-induced lift without the extensive mixing of drive gas and water produced by gas-lift devices. The principle of operation of a gas-displacement pump is shown schematically in [Fig. 8](#). Hydrostatic pressure opens the inlet check valve and fills the pump chamber (fill cycle). The inlet check valve closes by gravity after the chamber is filled. Pressurized gas is applied to the chamber, displacing the water up the discharge line (discharge cycle). By releasing the pressure, the cycle can be repeated. A check valve in the discharge line maintains the water in the line above the pump. A pneumatic logic unit, or controller, is used to control the application and release of the drive gas pressure. The lift capability of a gas displacement pump is directly related to the pressure of the drive gas used.

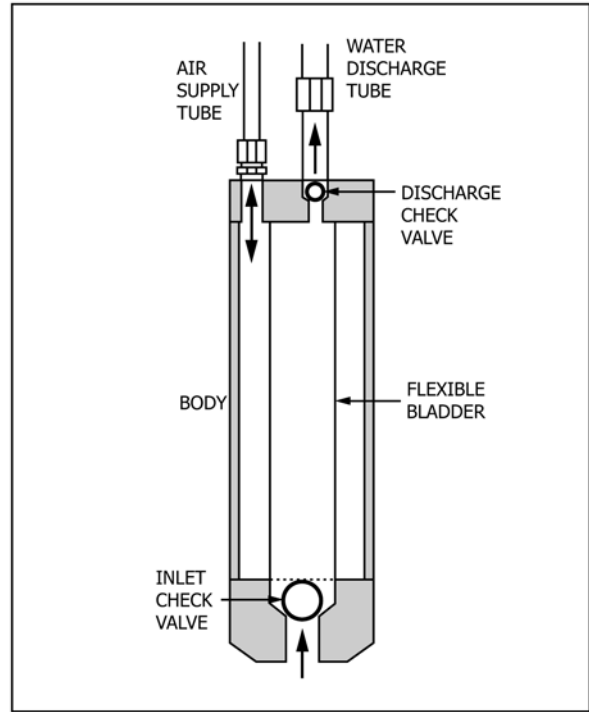
8.6.2 Within gas-displacement pumps, there is a limited interface between the drive gas and the water. There is, however, a potential for loss of dissolved gases and VOCs across this interface ([16, 17](#)). This potential greatly increases if the pump is allowed to discharge completely, which would cause drive gas to be blown up the discharge line. Contamination of the sample may result from impurities in the drive gas. Typical lifts for gas displacement pumps rarely exceed 75 m [250 ft] using single-stage compressors; greater lifts can be achieved using two-stage compressors or compressed-gas cylinders. Gas-displacement pumps can be used in wells as small as 19 mm [0.75 in.] in diameter.

**Example Of A Air Displacement Pump  
(Schematic Drawing)**



**FIG. 8 Example of an Air Displacement Pump**

**Example Of A Bladder Pump  
(Cross Section)**



**FIG. 9 Example of a Bladder Pump**

8.6.3 The maximum flow rate of a gas-displacement pump is based on the pump chamber volume, the pressure and volume of the drive gas source, the depth of the pump, and the submergence of the pump inlet. The flow rate can be controlled either by adjusting the pressure of the drive gas or the time allowed for the refill or discharge cycles to occur.

8.6.4 Gas-displacement pumps are not generally damaged by sediment, though it may reduce the maximum flow rate or temporarily clog the check valves and interrupt flow from the pump. These pumps are not damaged by pumping dry, so they are ideally suited for pumping in low-yield wells. They are typically easy to disassemble for cleaning, service or repair.

**8.7 Bladder Pumps:**

8.7.1 Bladder pumps, also known as gas-operated squeeze pumps or diaphragm pumps, consist of a flexible membrane tube (bladder) enclosed by a rigid housing. A schematic is shown in Fig. 9. Water enters the bladder under hydrostatic pressure through a check valve at the pump bottom. The inlet check valve closes by gravity after the bladder is filled. Compressed gas is applied to the annular space between the outside of the bladder and pump housing, which squeezes the bladder. This action forces the water out of the bladder and up the discharge line. By releasing the gas pressure, this cycle can be repeated; a check valve in the discharge line prevents discharged water from re-entering the bladder. In some bladder pump designs, the water and air chambers are reversed, with water entering the annular space between the pump housing and bladder; the bladder is then inflated to displace the water. A pneumatic logic controller, such as is used for gas-displacement pumps, controls the application and release of

drive gas pressure to the pump. The lift capability of bladder pumps, like gas-displacement pumps, is directly related to the pressure of the drive gas source.

8.7.2 Bladder pumps provide representative samples under a wide range of field conditions. There is no contact between the drive gas and the water in a bladder pump, greatly reducing the potential for stripping of dissolved gasses and VOCs and eliminating the potential for sample contamination by the drive gas. Pressure gradients applied to the sample can be controlled by reducing the drive gas pressure applied to the bladder, thus minimizing disturbance to the sample chemistry. Bladder pumps are acceptable for sampling of all parameters under field conditions (5, 6, 14, 15, 16, 18, 19, 20, 24).

8.7.3 Bladder pump flow rates are dependent upon the same factors as gas-displacement pumps, and are controlled by adjusting the drive gas pressure and the discharge and refill cycle timing. Where maximum flow rates are too low for purging, secondary purging pumps or packers can be used in conjunction with bladder sampling pumps in order to reduce purge time requirements.

8.7.4 Bladder pumps are susceptible to bladder damage or check valve malfunction, or both, from sediment; the use of inlet screens can minimize or eliminate these problems. Bladder pumps can be run dry without damage. Depending on design, they may be difficult to disassemble and clean for portable use applications.

**8.8 Piston Pumps:**

8.8.1 There are two common piston pump designs, single-acting and dual-acting. The most common type of single piston pump is the mechanical piston pump, referred to as the

stationary barrel type (Fig. 10). Pumps of this type consist of a plunger or set of plungers (pistons) moving inside of a stationary submerged barrel (cylinder). As the piston travels back and forth in the cylinder, it alternately draws water into the cylinder under suction, then displaces the water from the cylinder. In a single-acting piston pump, water is displaced in only one direction of piston movement; as water is displaced, the pump simultaneously refills. The piston can be cycled manually, or through the use of a pneumatic or mechanical actuator.

8.8.1.1 In a dual-acting piston pump (Fig. 11), water is simultaneously discharged and drawn in both directions of piston travel. A check valve in each discharge port or in the discharge line is used to prevent discharge water from re-entering the pump. The piston can be cycled manually, or through the use of a pneumatic or mechanical actuator.

8.8.2 Piston pumps can provide representative samples for some parameters (16, 24, 25). Samples may be altered due to the suction produced during refill of the pump; this effect is reduced as the pump cycling rate is decreased. Likewise, reducing the pump cycling rate also reduces the pressure applied to the sample, minimizing the potential for sample alteration. If a flow restrictor or valve is used to reduce the discharge rate, the resultant pressure changes could alter sample chemistry (16, 17).

8.8.3 The flow rate of a piston pump depends on the inside diameter of the pump cylinder and the stroke length and rate. The ability to control the minimum flow rate for sampling is dependent on the degree to which the stroke rate can be controlled.

Example Of A Pneumatic Dual-Acting Piston Pump (Cross Section)

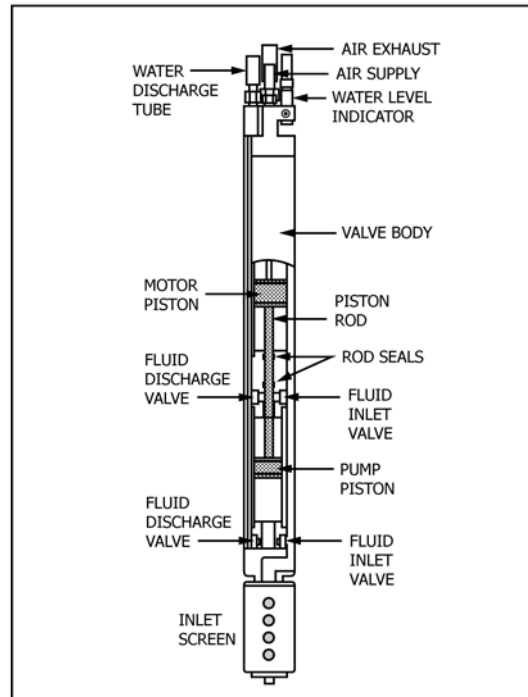


FIG. 11 Example of a Pneumatic Dual-Acting Piston Pump

8.8.4 Piston pumps are susceptible to damage from sediment, which can score the pump cylinder and piston seals. Inlet screens can reduce or eliminate this damage. These pumps may also be damaged by running dry, depending on design. Due to the use of rigid discharge pipe and actuator rod that is used with mechanically-actuated piston pumps, their use in portable applications may be difficult and impractical. Pneumatically-actuated piston pumps do not require rigid discharge pipe; however, due to a more complex design, they are difficult to disassemble for cleaning.

8.9 Progressive Cavity Pumps:

8.9.1 Progressive cavity pumps, also referred to as helical rotor pumps, utilize a down-hole rotor and stator assembly driven by an electric motor to displace water to ground surface. A schematic is shown in Fig. 12. Rotation of the helical rotor causes the cavity between the rotor and stator to progress upward, thereby pushing water in a continuous flow upward through the discharge line. In some progressive cavity pumps, the discharge rate can be varied by adjusting the speed of the pump motor between 50 and 500 rpm. The progressive cavity pump is typically suspended in a well by its discharge line. A two-conductor cable supplies electric power (typically from a 12-volt DC power supply and control box to the pump motor).

8.9.1.1 Progressive cavity pumps are commonly constructed of stainless steel with PTFE or PE materials, or both, used as seals. The rotors are generally constructed of stainless steel while the stator material may consist of EPDM or Buna-N.

8.9.2 The operating principle of progressive cavity pumps may make them suitable for collection of samples to be analyzed for VOCs (28). There is some evidence these pumps may not be suitable for sampling inorganic analytes at higher

Example Of A Mechanical Piston Pump (Cross Section)

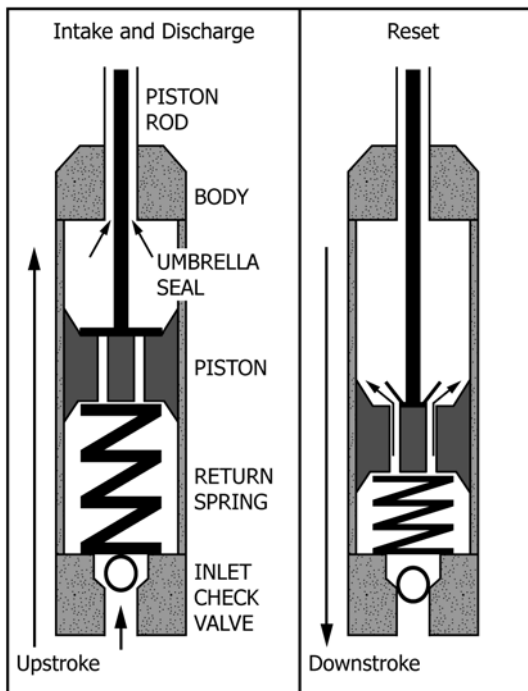
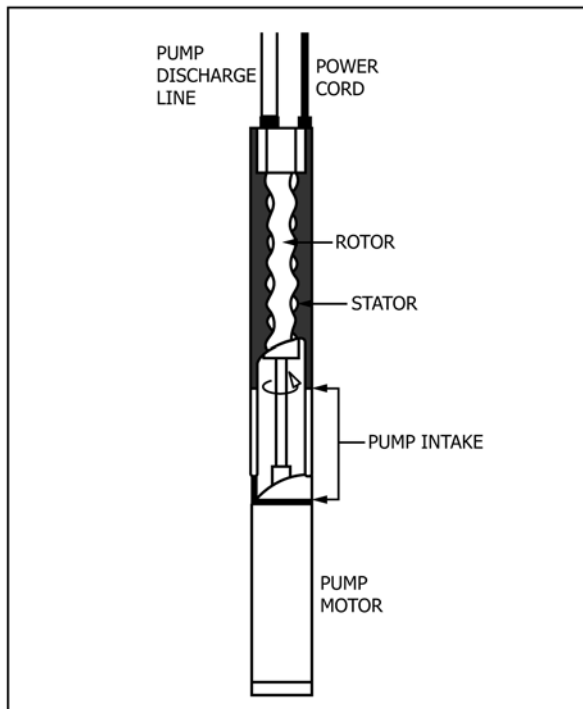
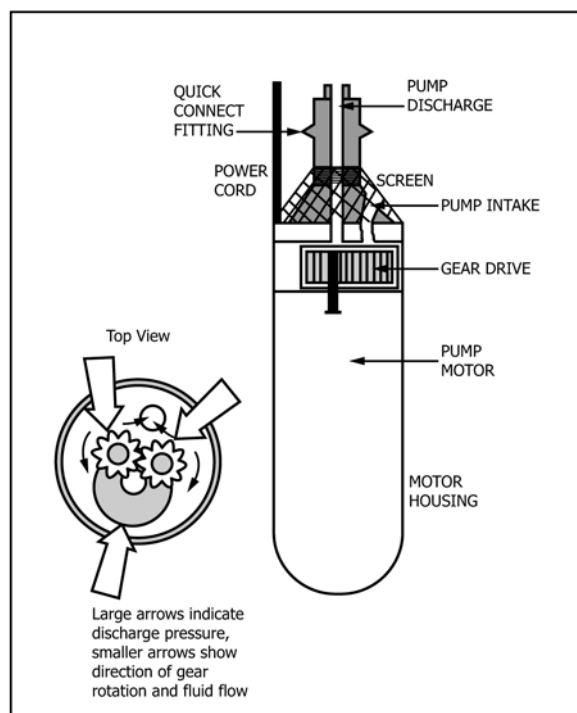


FIG. 10 Example of a Mechanical Piston Pump

**Example Of A Progressing Cavity Pump  
(Cross Section)**

**FIG. 12 Example of a Progressing Cavity Pump**
**Example Of A Gear Drive Pump  
(Cross Section)**

**FIG. 13 Example of a Gear Drive Pump**

flow rates due to increased turbidity (15); a variable speed pump controller should be used to reduce flow rate. The pressure applied to a sample is directly related to the motor speed, and can be controlled in designs using variable-speed motor controls. Overheating of the motor may raise the temperature of the sample, (5, 11).

8.9.3 The relatively low discharge rates attainable with most progressive cavity pumps may make them most useful in applications where purging does not require removal of large volumes of water from monitoring wells. With variable flow rate progressive cavity pumps, once purging is complete the discharge rate may be reduced before samples are collected. Where intermittent discharge has been determined to be undesirable, the continuous flow produced by progressive cavity pumps may be advantageous.

8.9.4 Due to their design and construction, progressive cavity pumps may be susceptible to damage by suspended solids in the pumped water. It may be difficult in the field to disassemble the pump mechanism to replace or repair damaged parts, repair malfunctioning or failed pump motors, or, if the pump is used portably, disassemble and reassemble the pump for decontamination.

### 8.10 Gear Pumps:

8.10.1 Another type of positive displacement electrical submersible pump is the gear pump, which is shown schematically in Fig. 13. In this type of pump, an electric motor drives a pair of PTFE gears. As these gears rotate, their advancing teeth draw water into the pump and push it upward in a continuous flow through the discharge line. With some gear pumps, the discharge rate can be varied by adjusting the speed

of the pump motor. As with many other submersible pumps, the gear pump is usually suspended in a well by its discharge line. Electric power is typically supplied to the 24-volt DC motor through cables from the power source and control box at ground surface.

8.10.1.1 Gear pump bodies are commonly constructed entirely of stainless steel materials while the gears are constructed of PTFE.

8.10.2 Gear pumps may provide adequate recoveries of VOCs and mobile colloids (23, 28). However, there may be potential for cavitation under certain conditions if the pump is run at high rpm. In addition, prolonged pumping under high lift or low flow conditions may cause the motor to overheat and raise the temperature of the sample. The pressure applied to a sample is directly related to the motor speed, and can be controlled in designs using variable-speed motor controls. Gear pumps are available that are constructed of materials acceptable for sampling of sensitive groundwater parameters.

8.10.3 Due to their relatively low discharge rates, gear pumps may not be useful in applications where purging large volumes of water is required. With variable flow rate gear pumps, once purging is complete the discharge rate may be reduced for sample collection.

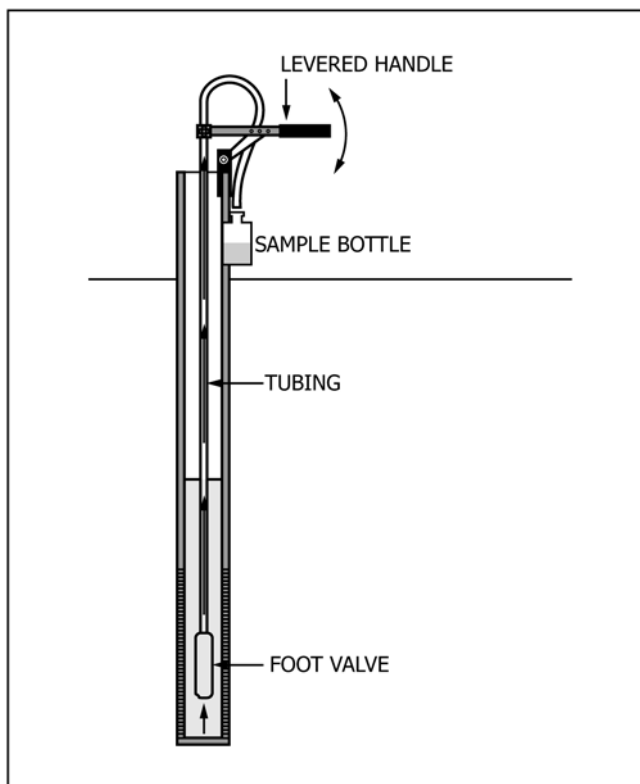
8.10.4 If gear pumps are used extensively for pumping water high in suspended solids, the PTFE gears may clog or wear, or both, thereby reducing the discharge rate. Disassembly of the pump and replacement of these gears is a procedure easily accomplished in the field. As a result, gear pumps are generally easy to decontaminate when used in a portable mode.



### 8.11 Inertial Lift Pumps:

8.11.1 Inertial lift pumps (Fig. 14) consist of a discharge line (either flexible tubing or rigid pipe) with a foot valve of a ball-check or other type design attached to the lower end of this line. In operation, the pump is lowered into a water column and cycled through reciprocating motion, either through manual action or the use of a reciprocating mechanical arm mechanism driven by an electric motor or internal combustion engine, to achieve discharge of water. As the pump is moved upward, water that has entered the pump under hydrostatic pressure is lifted upward, held in the pump by the seated foot valve. When

**Example Of A Inertia Lift Pump  
(Cross Section)**



**FIG. 14 Example of an Inertia Lift Pump**

the upward motion of the pump is stopped, the inertia of the water column inside the pump carries it out of the discharge line. As the pump is pushed downward the foot valve opens, allowing the pump to refill.

8.11.1.1 Inertial lift pumps can be constructed of any flexible tubing material or rigid discharge pipe that has sufficient strength to undergo the pump cycles. Typically, these materials include rigid and flexible PVC, PE, PP, and PTFE.

8.11.2 Available literature on inertial lift pumps indicates that they provide similar accuracy and precision to positive displacement bladder pumps for sampling of several volatile aromatic hydrocarbon compounds (3). If inertial-lift pumps are cycled rapidly prior to or during sample collection, some loss of VOCs or dissolved gasses, or both, could occur in the discharge stream. Inertial lift pumps do not cause pressure changes in the sample. The action of an inertial lift pump in a well can increase sample turbidity and mix water within the well bore, potentially altering analyte concentrations or interfering with analytical determinations.

8.11.3 The flow rate of an inertial lift pump is directly related to the cycling rate of the pump. Flexing of the tubing in the well can also affect the flow rate, causing it to drop. To achieve low discharge rates for sample collection, it is often necessary to insert a short length of small-diameter flexible tubing into the discharge line to divert a portion of the discharge stream into sample containers.

8.11.4 By nature of their simple design, inertial lift pumps are not susceptible to damage by suspended solids or dry pumping, though check valve clogging will reduce the flow rate during operation. Some wear or damage may occur on the outer surface of the foot valve or discharge line, or both, as it comes in contact with the well casing or screen, or both, or open borehole during cycling. These pumps are easily disassembled in the field for repairs if needed, though the mechanical cycling mechanisms may be difficult or impossible to repair in the field.

## 9. Keywords

9.1 groundwater; groundwater monitoring; groundwater monitoring wells; groundwater sampling; groundwater sampling devices; purging devices

## REFERENCES

- (1) Barcelona, M. J., Helfrich, J. A., Garske, E. E., 1985. Sample Tubing Effects on Ground Water Samples, *Analytical Chemistry*, 57 (2), 1985, pp. 460-464.
- (2) Ho, J. S-Y., 1983. Effects of Sampling Variables on Recovery of Volatile Organics in Water, *Journal of the AWWA*, December 1983, pp. 583-586.
- (3) Barker, J. F., and Dickhout, R., 1988. "An Evaluation of Some Systems for Sampling Gas-Charged Ground Water for Volatile Organic Analysis," *Ground Water Monitoring Review*, Vol. 8, No. 4, pp. 112-120.
- (4) Barcelona, M. J., Gibb, J. P., and Miller, R. A., 1983. A Guide to the Selection of Materials for Monitoring Well Construction and Ground Water Sampling, Illinois State Water Survey, Contract Report CR-327.
- (5) Parker, L. V. 1994a. The Effects of Ground Water Sampling Devices on Water Quality: A Literature Review. *Ground Water Monitoring and Remediation*, Vol. 14, No. 2, pp. 130-141.
- (6) Parker, L. V. 1994b. Correction. *Ground Water Monitoring and Remediation*, Vol. 14, No. 3, p. 275.
- (7) Barcelona, M. J. and Helfrich, J. A., 1986. Well Construction and Purging Effects on Ground-Water Samples, *Environmental Science and Technology*, Vol.20, No. 11, pp. 1179-1184.
- (8) Gillham, R. W. and O'Hannesin, S. F., 1990. Sorption of Aromatic Hydrocarbons by Materials Used in Construction of Ground-Water Sampling Wells, *Ground Water and Vadose Zone Monitoring*, ASTM STP 1053, D. M. Nielsen and A. I. Johnson, Eds., American Society for Testing and Materials, Philadelphia, PA, pp. 108-122.



- (9) Parker, L. V., 1992. Suggested Guidelines for the Use of PTFE, PVC and Stainless Steel in Samplers and Well Casings, Current Practices in Ground-Water and Vadose Zone Investigations, ASTM STP 1118, David M. Nielsen and Martin N. Sara, Editors, American Society for Testing and Materials, Philadelphia, PA, pp. 217-229.
- (10) Holm, T. R., George, G. K., and Barcelona, M. J., 1988. Oxygen Transfer Through Flexible Tubing and Its Effects on Ground-Water Sample Results, Ground Water Monitoring Review, Vol. 8, No. 3, pp. 83-89.
- (11) Stumm, W. and Morgan, J. J., 1996. Aquatic Chemistry: Chemical Equilibria and Rates in Natural Waters, Third Edition. John Wiley & Sons, Inc.
- (12) Lee, G. F. and Jones, R. A., 1983. Guidelines for Sampling Ground Water, Journal of the Water Pollution Control Federation, Vol. 55, No. 1, pp. 92-96.
- (13) Puls, R.W. and Barcelona, M. J. 1996. Low-Flow (Minimal Draw-down) Ground-Water Sampling Procedures. U.S. Environmental Protection Agency, Publication Number EPA/540/S-95/504. 12 pages.
- (14) Kearn, P. M., Korte, N. E. and Cronk, T. A., 1992. Suggested Modifications to Ground Water Sampling Procedures Based on Observations from the Colloidal Borescope, Ground Water Monitoring Review, Vol.12, No.2, pp.155-161.
- (15) Puls, R.W., Clark, D. A., Bledsoe, B., Powell, R. M. and Paul, C. J., 1992. Metals in Ground Water: Sampling Artifacts and Reproducibility, Hazardous Waste and Hazardous Materials, Vol. 9, No.2, pp. 149-162.
- (16) Barcelona, M. J., Helfrich, J. A., Garske, E. E. and Gibb, J. P., 1984. A Laboratory Evaluation of Ground Water Sampling Mechanisms, Ground Water Monitoring Review, Vol. 4, No.2, pp. 32-41.
- (17) Gillham, R. W., Robin, M. J. L., Barker, J. F. and Cherry, J. A., 1983. Ground Water Monitoring and Sample Bias, American Petroleum Institute Publication 4367.
- (18) Pohlmann, K. F., Blegen, R. P., and Hess, J. W., 1990. "Field Comparison of Ground-Water Sampling Devices for Hazardous Waste Sites: An Evaluation Using Volatile Organic Compounds," U.S. Environmental Protection Agency, Publication No. EPA/600/4-90/028, 102 pages.
- (19) Unwin, J. and Maltby, V. 1988. Investigations of techniques for purging ground-water monitoring wells and sampling ground water for volatile organic compounds. In Ground-Water Contamination: Field Methods, ASTM STP 963, ed. A. G. Collins and A. I. Johnson, pp. 240-252. Philadelphia, PA: American Society for Testing and Materials.
- (20) Tai, D. Y., Turner, K. S. and Garcia, L. A. 1991. The Use of a Standpipe to Evaluate Ground-Water Samplers. Ground Water Monitoring Review, Vol. 11, No. 1, pp. 125-132.
- (21) Canova, J. L. and Muthig, M. G. 1991. The Effect of Latex Gloves and Nylon Cord on Ground Water Sample Quality. Ground Water Monitoring Review, Vol. 11, No. 3, pp. 98-103.
- (22) Puls, R. W. and Powell, R. M. 1992. Acquisition of Representative Ground Water Quality Samples for Metals. Ground Water Monitoring Review, Vol. 12, No. 3, pp. 167-176.
- (23) Backhus, D. A., Ryan, J. N., Groher, D. M., MacFarlane, J. K. and Gschwend, P. M., 1993. Sampling Colloids and Colloid-Associated Contaminants in Ground Water. Ground Water, Vol. 31, No. 3, pp. 466-479.
- (24) Pohlmann, K. F., and Hess, J. W., 1988. Generalized Ground Water Sampling Device Matrix, Ground Water Monitoring Review, Vol. 8, No. 4, pp. 82-84.
- (25) Knobel, L. L. and Mann, L. J. 1993. Sampling for purgeable organic compounds using positive-displacement piston and centrifugal submersible pumps: A comparative study. Ground Water Monitoring and Remediation, Vol. 13, No.2, pp. 142-148.
- (26) Pearsall, K. A. and Eckhardt, D. A. V., 1987. Effects of Selected Sampling Equipment and Procedures on the Concentrations of Trichloroethylene and Related Compounds in Ground Water Samples. Ground Water Monitoring Review, Vol. 7, No. 2, pp. 64-73.
- (27) Pohlmann, K. F., Icopini, G. A., McArthur, R.D. and Rosal, C.G., 1994. Evaluation of Sampling and Field Filtration Methods for the Analysis of Trace Metals in Ground Water. U.S. Environmental Protection Agency, Publication No. EPA/600/R-94/119, 79 pages.
- (28) Imbrigiotta, T. E., Gibs, J., Fusillo, T. V., Kish, G. R., and Hochreiter, J. J., 1988. Field Evaluation of Seven Sampling Devices for Purgeable Organic Compounds in Ground Water, Ground Water Contamination: Field Methods, ASTM STP 963, A. G. Collins and A. I. Johnson, Editors, American Society for Testing and Materials, Philadelphia, PA, pp. 258-273.

## SUMMARY OF CHANGES

Committee D18 has identified the location of selected changes to this standard since the last issue (D6634-01 (Reapproved 2006)) that may impact the use of this standard. (Approved Feb. 1, 2014.)

- (1) Corrected the spelling of groundwater throughout document.
- (2) Corrected absolute, limiting, jargon and other grammatical errors.
- (3) Added new Section 3 on Terminology.
- (4) Added new section on Summary of Changes.
- (5) Converted to combined SI/Inch-pound standard.
- (6) Added new 1.4 and renumbered following sections.
- (7) Added Practice D3740 to list of referenced ASTM standards, and added note to Significance and Use Section.
- (8) Swapped Tables 1 and 2 to make SI units first.
- (9) Editorial corrections throughout.
- (10) Incorporated prior 5.1 into the Significance and Use Section.
- (11) Created new Section 6 Apparatus.
- (12) Added non-mandatory Note 2 regarding consistency in equipment used.



*ASTM International takes no position respecting the validity of any patent rights asserted in connection with any item mentioned in this standard. Users of this standard are expressly advised that determination of the validity of any such patent rights, and the risk of infringement of such rights, are entirely their own responsibility.*

*This standard is subject to revision at any time by the responsible technical committee and must be reviewed every five years and if not revised, either reapproved or withdrawn. Your comments are invited either for revision of this standard or for additional standards and should be addressed to ASTM International Headquarters. Your comments will receive careful consideration at a meeting of the responsible technical committee, which you may attend. If you feel that your comments have not received a fair hearing you should make your views known to the ASTM Committee on Standards, at the address shown below.*

*This standard is copyrighted by ASTM International, 100 Barr Harbor Drive, PO Box C700, West Conshohocken, PA 19428-2959, United States. Individual reprints (single or multiple copies) of this standard may be obtained by contacting ASTM at the above address or at 610-832-9585 (phone), 610-832-9555 (fax), or [service@astm.org](mailto:service@astm.org) (e-mail); or through the ASTM website ([www.astm.org](http://www.astm.org)). Permission rights to photocopy the standard may also be secured from the Copyright Clearance Center, 222 Rosewood Drive, Danvers, MA 01923, Tel: (978) 646-2600; <http://www.copyright.com/>*