



Standard Test Method for Evaluation of Engine Oils in Diesel Four-Stroke Cycle Supercharged 1M-PC Single Cylinder Oil Test Engine¹

This standard is issued under the fixed designation D6618; the number immediately following the designation indicates the year of original adoption or, in the case of revision, the year of last revision. A number in parentheses indicates the year of last reapproval. A superscript epsilon (ϵ) indicates an editorial change since the last revision or reapproval.

INTRODUCTION

This test method can be used by any properly equipped laboratory, without outside assistance. However, the ASTM Test Monitoring Center (TMC)² provides reference oils and an assessment of the test results obtained on those oils by the laboratory. By this means, the laboratory will know whether their use of the test method gives results statistically similar to those obtained by other laboratories. Furthermore, various agencies require that a laboratory utilize the TMC services in seeking qualification of oils against specifications. For example, the U.S. Army imposes such a requirement, in connection with several Army engine lubricating oil specifications.

Accordingly, this test method is written for use by laboratories that utilize the TMC services. Laboratories that choose not to use those services may simply ignore those portions of the test method that refer to the TMC.

This test method may be modified by means of Information Letters issued by the TMC. In addition, the TMC may issue supplementary memoranda related to the test method.

1. Scope*

1.1 This test method covers a four-stroke cycle diesel engine test procedure for evaluating engine oils for certain high-temperature performance characteristics, particularly ring sticking, ring and cylinder wear, and accumulation of piston deposits. Such oils include both single viscosity SAE grade and multiviscosity SAE grade oils used in diesel engines. It is commonly known as the 1M-PC test (PC for Pre-Chamber) and is used in several API oil categories, notably the CF and CF-2 and the military category described in MIL-PRF-2104 (see Note 1).

NOTE 1—Companion test methods used to evaluate other engine oil performance characteristics for API oil categories CF and CF-2 are discussed in SAE J304. The companion tests used by the military can be found in MIL-PRF-2104.

1.2 The values stated in SI units are to be regarded as standard.

¹ This test method is under the jurisdiction of ASTM Committee D02 on Petroleum Products, Liquid Fuels, and Lubricants and is the direct responsibility of Subcommittee D02.B0.02 on Heavy Duty Engine Oils. The test engine sequences were originally developed in 1956 by ASTM Committee D02. Subsequently, the procedures were published in an ASTM Special Technical Publication.

Current edition approved April 1, 2016. Published June 2016. Originally approved in 2000. Last previous edition approved in 2014 as D6618 – 14. DOI: 10.1520/D6618-16.

² ASTM Test Monitoring Center, 6555 Penn Avenue, Pittsburgh, PA 15206-4489. The TMC issues Information Letters that supplement this test method. This edition incorporates revisions contained in all information letters through No. 15–1.

1.2.1 *Exception*—The values in parentheses are provided for information only.

1.3 *This standard does not purport to address all of the safety concerns, if any, associated with its use. It is the responsibility of the user of this standard to establish appropriate safety and health practices and determine the applicability of regulatory limitations prior to use.*

1.4 This test method is arranged as follows:

TABLE OF CONTENTS

Scope	1
Reference Documents	2
Terminology	3
Summary of Test Method	4
Significance and Use	5
Apparatus	6
Test Engine	6.1
Engine Accessories	6.2 – 6.14
Engine Oil System	6.15
Cooling System	6.16
Fuel System	6.17
Intake Air System	6.18
Exhaust System	6.19
Blowby Meter	6.20
Thermocouples	6.21
Parts	6.22
Instrumentation	6.23
Crankcase Paint	6.24
Reagents and Materials	7
Fuel	7.1
Test Oil	7.2
Engine Coolant	7.3
Cleaning Materials	7.4
Safety	8

*A Summary of Changes section appears at the end of this standard

Preparation of Apparatus	9
Supplementary Service Information	9.1
General Engine Inspection	9.2
Intake Air System	9.3
Cooling System	9.4
Engine Cooling System Cleaning	9.5
Instrumentation Calibration Requirements	9.6
Engine Crankcase Cleaning	9.7
Additional Oil Filter	9.8
Flushing Procedure Components	9.9
Flushing Procedures	9.10
Piston Cleaning Preparation	9.11
Cylinder Head	9.12
Fuel Nozzle	9.13
Measurement	9.14
Procedure	10
Engine Break-in	10.1
Pre-Test Preparations	10.2
Warm-up Procedure	10.3
Operating Conditions	10.4
Periodic Measurements	10.5
Engine Oil Level	10.6
Oil Addition Procedure	10.7
Cool-Down Procedure	10.8
Shutdowns	10.9
Fuel System	10.10
Brake Specific Oil Consumption (BSOC) Calculation	10.11
Inspection	11
Preparation	11.1
Inspection	11.2
Rater Training	11.3
Referee Ratings	11.4
Calibration of Test Method	12
Requirements	12.1
Reference Oils	12.2
Test Numbering	12.3
Definition of a Test	12.4
New Laboratories and New Test Stands	12.5
Frequency of Calibration Tests	12.6
Specified Test Parameters	12.10
Acceptance of Calibration Tests	12.11
Failing Reference Oil Calibration Tests	12.12
Non-Standard Tests	12.13
Severity Adjustments and Control Charting	12.14
Test Reporting	12.15
Reporting Reference Results	12.16
Analysis of Reference Oils	12.17
Precision and Bias	13
Precision	13.1
Bias	13.2
Keywords	14

ANNEXES

Figures and Schematics	Annex A1
Report Forms	Annex A2
Test Fuel Information	Annex A3

APPENDIXES

Humidity Correction Factors	Appendix X1
Report Form Examples	Appendix X2
1M-PC Multiple Testing	Appendix X3

2. Referenced Documents

2.1 ASTM Standards:³

- D86 Test Method for Distillation of Petroleum Products and Liquid Fuels at Atmospheric Pressure
- D93 Test Methods for Flash Point by Pensky-Martens Closed Cup Tester

- D97 Test Method for Pour Point of Petroleum Products
 - D130 Test Method for Corrosiveness to Copper from Petroleum Products by Copper Strip Test
 - D235 Specification for Mineral Spirits (Petroleum Spirits) (Hydrocarbon Dry Cleaning Solvent)
 - D445 Test Method for Kinematic Viscosity of Transparent and Opaque Liquids (and Calculation of Dynamic Viscosity)
 - D482 Test Method for Ash from Petroleum Products
 - D524 Test Method for Ramsbottom Carbon Residue of Petroleum Products
 - D613 Test Method for Cetane Number of Diesel Fuel Oil
 - D664 Test Method for Acid Number of Petroleum Products by Potentiometric Titration
 - D1319 Test Method for Hydrocarbon Types in Liquid Petroleum Products by Fluorescent Indicator Adsorption
 - D1796 Test Method for Water and Sediment in Fuel Oils by the Centrifuge Method (Laboratory Procedure)
 - D2422 Classification of Industrial Fluid Lubricants by Viscosity System
 - D2425 Test Method for Hydrocarbon Types in Middle Distillates by Mass Spectrometry
 - D2500 Test Method for Cloud Point of Petroleum Products and Liquid Fuels
 - D2622 Test Method for Sulfur in Petroleum Products by Wavelength Dispersive X-ray Fluorescence Spectrometry
 - D4052 Test Method for Density, Relative Density, and API Gravity of Liquids by Digital Density Meter
 - D4175 Terminology Relating to Petroleum Products, Liquid Fuels, and Lubricants
 - D4294 Test Method for Sulfur in Petroleum and Petroleum Products by Energy Dispersive X-ray Fluorescence Spectrometry
 - D4485 Specification for Performance of Active API Service Category Engine Oils
 - D4863 Test Method for Determination of Lubricity of Two-Stroke-Cycle Gasoline Engine Lubricants
 - D5302 Test Method for Evaluation of Automotive Engine Oils for Inhibition of Deposit Formation and Wear in a Spark-Ignition Internal Combustion Engine Fueled with Gasoline and Operated Under Low-Temperature, Light-Duty Conditions (Withdrawn 2003)⁴
 - D5844 Test Method for Evaluation of Automotive Engine Oils for Inhibition of Rusting (Sequence IID) (Withdrawn 2003)⁴
 - D5862 Test Method for Evaluation of Engine Oils in Two-Stroke Cycle Turbo-Supercharged 6V92TA Diesel Engine (Withdrawn 2009)⁴
 - D6202 Test Method for Automotive Engine Oils on the Fuel Economy of Passenger Cars and Light-Duty Trucks in the Sequence VIA Spark Ignition Engine (Withdrawn 2009)⁴
- ### 2.2 SAE Standard:⁵
- SAE J304 Engine Oil Tests

³ For referenced ASTM standards, visit the ASTM website, www.astm.org, or contact ASTM Customer Service at service@astm.org. For *Annual Book of ASTM Standards* volume information, refer to the standard's Document Summary page on the ASTM website.

⁴ The last approved version of this historical standard is referenced on www.astm.org.

⁵ Available from SAE International (SAE), 400 Commonwealth Dr., Warrendale, PA 15096, <http://www.sae.org>.

2.3 *Military Standard*.⁶

MIL-PRF-2104 Lubricating Oil, Internal Combustion Engine, Combat/Tactical Service

2.4 *Other ASTM Document*:

ASTM Deposit Rating Manual 20 (formerly **CRC Manual 20**)⁷

3. Terminology

3.1 *Definitions*:

3.1.1 *calibrate*, *v*—to determine the indication or output of a measuring device with respect to that of a standard. **D4175**

3.1.2 *candidate oil*, *n*—an oil that is intended to have the performance characteristics necessary to satisfy a specification and is tested against that specification. **D5844**

3.1.3 *clogging*, *n*—the restriction of a flow path due to the accumulation of material along the flow path boundaries. **D5844**

3.1.4 *engine oil*, *n*—a liquid that reduces friction or wear, or both, between the moving parts within an engine; removes heat, particularly from the underside of pistons; and serves as a combustion gas sealant for the piston rings. **D5862**

3.1.4.1 *Discussion*—It may contain additives to enhance certain properties. Inhibition of engine rusting, deposit formation, valve train wear, oil oxidation, and foaming are examples.

3.1.5 *non-reference oil*, *n*—any oil other than a reference oil: such as a research formulation, commercial oil, or candidate oil. **D5844**

3.1.6 *purchaser*, *n*—of an ASTM test, a person or organization that pays for the conduct of an ASTM test method on a specified product. **D6202**

3.1.6.1 *Discussion*—The preferred term is *purchaser*. Deprecated terms that have been used are *client*, *requester*, *sponsor*, and *customer*.

3.1.7 *reference oil*, *n*—an oil of known performance characteristics, used as a basis for comparison. **D5844**

3.1.7.1 *Discussion*—Reference oils are used to calibrate testing facilities, to compare the performance of other oils, or to evaluate other materials (such as seals) that interact with oils.

3.1.8 *scuff*, *scuffing*, *n*—in lubrication, damage caused by instantaneous localized welding between surfaces in relative motion which does not result in immobilization of the parts. **D4863**

3.1.9 *wear*, *n*—the loss of material from, or relocation of material on, a surface. **D5302**

3.1.9.1 *Discussion*—Wear generally occurs between two surfaces moving relative to each other and is the result of mechanical or chemical action or by a combination of mechanical and chemical actions.

3.2 *Definitions of Terms Specific to This Standard*:

3.2.1 *calibration test*, *n*—an engine test conducted on a reference oil under carefully prescribed conditions whose result is used to determine the suitability of the engine stand/laboratory to conduct such tests on non-reference oils.

3.2.1.1 *Discussion*—In this test method, it can also refer to tests conducted on parts to ensure their suitability for use in reference or non-reference tests.

3.2.2 *test*, *n*—any test time accumulated in accordance with this test method.

4. Summary of Test Method

4.1 Prior to each test run, the power section of the engine (excluding piston assembly) is completely disassembled, solvent-cleaned, measured, and rebuilt in strict accordance with furnished specifications. A new piston, piston ring assembly, and cylinder liner are installed each test. The engine crankcase is solvent-cleaned, and worn or defective parts are replaced. The test stand is equipped with appropriate accessories for controlling speed, fuel rate, and various engine operating conditions. A suitable system for supercharging the engine with humidified and heated air shall also be provided.

4.2 Test operation involves the control of the supercharged, single-cylinder diesel test engine for a total of 120 h at a fixed speed and fuel rate, using the test oil as a lubricant. A 1 h engine break-in precedes each test. At the conclusion of the test, the piston, rings, and cylinder liner are examined. Note the degree of cylinder liner and piston ring wear, the amount and nature of piston deposits present, and whether any rings are stuck.

5. Significance and Use

5.1 The test method is designed to relate to high-speed, supercharged diesel engine operation and, in particular, to the deposit control characteristics and antiwear properties of diesel crankcase lubricating oils.

5.2 The test method is useful for the evaluation of diesel engine oil quality and crankcase oil specification acceptance. This test method, along with others, defines the minimum performance level of the API categories CF and CF-2 (detailed information about passing limits for these categories is included in Specification **D4485**). It is also used in MIL-PRF-2104.

5.3 The results are significant only when *all details* of the procedure are followed. The basic engine used in this test method has a precombustion chamber (as compared to direct injection) and is most useful in predicting performance of engines similarly equipped. This factor should be considered when extrapolating test results. It has been found useful in predicting results with high sulfur fuels (that is, greater than 0.5 % by mass) and with certain premission controlled engines. It has also been found useful when correlated with deposit control in two-stroke cycle diesel engines.

6. Apparatus

6.1 *Test Engine*—A single-cylinder Caterpillar diesel oil test engine having a 2.2 L (134.1 in.³) displacement is required. Bore and stroke are 13.0 cm (5.125 in.) and 16.5 cm (6.5 in.)

⁶ Available from Standardization Documents Order Desk, Building 4, Section D, 700 Robbins Avenue, Philadelphia, PA 19111-5904, Attn: NPODS.

⁷ For Stock #TMCML20, visit the ASTM website, www.astm.org, or contact ASTM International Customer Service at service@astm.org.

respectively. The engine arrangement is shown in Fig. A1.1. The supply of test engines and parts is discussed in 6.22. The engine is equipped with the accessories or equipment listed in 6.2 through 6.24.

6.2 *Air Pressure*—Use a supercharging blower or other device arranged to control air pressure.

6.3 *Air Intake System*—Use the 1Y38 surge chamber and the air heater mechanism (see Annex A1) or its equivalent.

6.4 *Humidity*—Use a system to control humidity to the specified test conditions.

6.5 *Cooling System*—Use a closed, pressurized, circulating cooling system having an engine-driven centrifugal water pump.

6.6 *Speed/Load Controls*—Use a dynamometer or suitable loading device to control engine speed and measure load.

6.7 *Starting*—Use a suitable starting arrangement capable of 420 N·m (310 lbf·ft) breakaway and 373 N·m (275 lbf·ft) sustained torque at approximately 200 r/min.

6.8 *Exhaust System*—Use an exhaust system using piping and an exhaust barrel as specified in Annex A1. A restriction valve down stream of the barrel maintains the exhaust gases at a given back pressure as specified in the test conditions.

6.9 *Data Acquisition*—Configure all stands to acquire data automatically for speed, fuel flow, intake air pressure, intake air temperature, coolant temperature, oil-to-bearing temperature, and oil-to-jet pressure (as a minimum) with closed loop control on speed, intake air temperature, coolant temperature, and oil-to-bearing temperature (as a minimum).

6.10 *Cylinder Head and Cylinder Assemblies*—Only cylinder head and cylinder assemblies that have previously passed a calibration test are acceptable for non-reference testing.

6.11 *Piston Cooling Nozzle:*

6.11.1 *Oil Jet Pressure Measurement*—The following is required to allow for measurement of the piston cooling nozzle pressure:

6.11.1.1 Replace the 3B9407 fitting with a ¼ in. tee fitting, and reconnect the 1Y6 oil line.

6.11.1.2 Modify the 1Y8199 oil pan to provide access for the pressure pickup.

6.11.1.3 Use oil pressure gauge 8M2743, or equivalent.

6.11.1.4 Only piston cooling jets that have been flow-checked by the specified industry standard are approved for use. See footnote 11 for supplier. Fig. A1.2 shows the suggested modification of the 1Y8199 oil pan and necessary hardware for the cooling nozzle pressure pickup. All test engines with serial numbers greater than 2511252 will be provided with the pressure pickup modification.

6.11.2 *Piston Cooling Jet Supplier*—To improve precision, Perkin Elmer Automotive Research and Southwest Research Institute (SWRI) have agreed to provide flow-checked 1M-PC P-tubes to the industry. Perkin Elmer Automotive Research will flow and serialize the units and determine if they are within specification and will maintain records, while SWRI

will coordinate the redistribution. Send P-tubes to be inspected to Perkin Elmer Automotive Research.⁸

6.11.2.1 The P-tubes will be flowed, using EF-411 oil at 37.8 °C ± 0.6 °C (100 °F ± 1 °F) and 165.5 kPa ± 0.5 kPa (24 psi ± 0.5 psi) as measured at the location shown in Fig. A1.2. The acceptable flow range is 1.89 L/min to 2.27 L/min (0.50 gal/min to 0.60 gal/min).

6.11.2.2 To maintain impartiality in selecting P-tubes, only acceptable assemblies will be forwarded to SWRI as unmarked units. These units will be randomly selected for redistribution. In cases in which the only units available are from a single order, only those units will be returned. Assemblies that fall outside of the specifications will not be returned. Instead, Perkin Elmer Automotive Research will generate a nonconformance report with an additional copy to be sent to the laboratory that supplied the P-tube. The failed units will be returned to Caterpillar for credit. Perkin Elmer Automotive Research will indicate on the nonconformance report that the appropriate credit be issued to the originating laboratory. Additional piston cooling assemblies will need to be supplied by the requesting laboratory and submitted to Perkin Elmer Automotive Research.

6.11.2.3 Perkin Elmer Automotive Research will enclose a statement with each unit inspected, disclaiming any liability for subsequent performance of the part. No attempt will be made to ensure that the tubing is properly configured or that any other physical property makes it suitable for use. Units damaged during shipment will not be tested, unless specifically requested. Include a packing list and separate purchase orders to Perkin Elmer Automotive Research and SWRI⁹ with each shipment. Please specify a name and address where the parts are to be returned.

6.12 *Engine Oil Level Gauge*—Lower the bayonet gauge housing 5 cm (2.0 in.) to provide for more accurate oil level readings. Parts required for this modification are shown in Fig. A1.3.

6.13 *Crankcase Pressure Control Valve*—Install a pressure control valve (1Y479) at the crankcase breather outlet to stabilize crankcase pressure. Installation is shown in Fig. A1.4.

6.14 *Oil Cooler Inlet Temperature*—Record the temperature of the oil cooler inlet by installing a thermocouple in the pipe-tapped hole provided on the rear side of the oil-cooler cover adjacent to the oil inlet port. Care should be taken to provide sufficient thermocouple insertion depth to provide a mid-stream oil temperature.

6.15 *Engine Oil System*—Use the *last chance* screen 1Y3549. Modify the oil pump as shown in Fig. A1.10. Add the external oil pump bypass line for safety and convenience factors to adjust oil pressure on engine break-in and warm-up.

6.16 *Cooling System*—Replace the 7.6 cm (3 in.) standard cooling tower with the 12.7 cm (5 in.) pressurized cooling tower as shown in Fig. A1.6. Modify the cooling system to

⁸ Send P-tubes to be inspected to Perkin Elmer Automotive Research, 5404 Bandera Road, San Antonio, TX 78238.

⁹ Southwest Research Institute, 6220 Culebra Road, P.O. Drawer 28510, San Antonio, TX 78228-0510.

accommodate the pressurized cooling tower, bypass flow control and flow meter as shown in Fig. A1.7 and Fig. A1.8. Use a Barco Venturi Meter #BR 12705-16-31.^{10,11} Use brass or stainless steel pipe that has chamfered ends (45°) into and out of the venturi meter [15.2 cm (6 in.) minimum into and 5.1 cm (2 in.) minimum out]. Orient the high pressure tap (the first seen by the flow) horizontally.

6.17 *Fuel System*—Use a standardized engine fuel system to ensure that fuel-line pressure transients are held to acceptable values and to minimize cranking times. Use a Micro Motion flow meter^{12,11} having a range no greater than 0 kg/h to 90.7 kg/h (0 lb/h to 200 lb/h) to measure fuel flow rate.

6.17.1 The line lengths, line sizes, and fuel system components are shown in Fig. A1.5. Use this system without modification, with the possible exception that the fuel shut-off solenoid^{13,11} is eliminated if the line length from the engine-mounted filter to the injector pump is standardized at 107 cm ± 1 cm (42.25 in. ± 0.5 in.). Also, an external fuel pump may be used in place of the engine-mounted fuel pump. Control the fuel rate with either manual or automated fuel rack manipulation.

6.18 *Intake Air System*—Install a dry element oil and particle filter between the air supply source and each engine to be run. Use an air filter capable of 10 µm (or smaller) filtration. (Oil bath filters are not acceptable in this location.) Make air filter replacements as required to minimize pressure losses and with sufficient frequency to maintain the air heater barrel as free as possible from oil and dust particles. The 1Y38 surge chamber and air heater assembly required is shown in Annex A1.

6.18.1 Suitable equipment is required to maintain the specified moisture content, temperature, and pressure of the inlet air to the cylinder head. The accuracy of the humidification system is to be within ±0.648 g (±10 grains) of the humidity-measuring, chilled-mirror dew point hygrometer (see 9.6.2).

6.19 *Exhaust System*—Uniformity in exhaust system pressure patterns within a laboratory and from laboratory-to-laboratory is required to minimize a major test variable. The dimensions and distance of the exhaust piping from the exhaust elbow to the barrel, as well as the volume of the exhaust barrel, are specified in Figs. A1.30-A1.34. Note the exhaust barrel may be insulated or water cooled. The downstream distance of the restriction valve from the exhaust barrel is not specified.

6.19.1 Set the exhaust pressure at specified conditions as given in Table 1 by varying the restriction valve. Measure the pressure in the exhaust barrel as shown in Fig. A1.31. The location of the 1Y467 or equivalent exhaust thermocouple is shown in Fig. A1.30.

6.20 *Blowby Meter*, a displacement type gas meter or equivalent fitted with an oil separator and surge chamber. A fitting on the crankcase breather (see Fig. A1.4) permits attachment of the meter to the engine by using appropriate lengths of hose or pipe, or both, suitable to the laboratory’s needs.

6.21 *Thermocouples*—Specified thermocouples (or equivalents) are required for obtaining temperatures at the following locations: air-to-engine (1Y468), exhaust temperature (1Y467), and water inlet, water outlet, oil-to-bearings (1Y466).

6.21.1 Install thermocouples 1Y468, 1Y467, and 1Y466 only at the temperature-sensing locations provided with the 1Y73 engine arrangement. Locate the immersion depth for water inlet, water outlet, and oil-to-bearing temperature sensors so that the tip of the sensor is midstream of the fluid measured. Immersion depth for the air and exhaust temperature sensors are measured as follows (variation from these dimensions is not permitted):

6.21.1.1 Air temperature sensor depth: 27 mm ± 2 mm (1 1/16 in. ± 1/16 in.)

¹⁰ Available from J. P. Bushnell, 3436 Lindell Blvd., St. Louis, MO.

¹¹ The sole source of supply of the apparatus known to the committee at this time is noted in the adjoining footnote. If you are aware of alternative suppliers, please provide this information to ASTM Headquarters. Your comments will receive careful consideration at a meeting of the responsible technical committee,¹ which you may attend.

¹² Available from Micro Motion, Inc., 7070 Winchester Circle, Boulder, CO 80301.

¹³ Available from Asco, Florham Park, New Jersey 07932.

TABLE 1 1M-PC Operating Conditions^{A,B}

Speed, r/min	1800 ± 10
Fuel flow, kg/h (lb/h)	8.13 ± 0.07 (17.92 ± 0.15)
Temperature, water from cylinder head, °C (°F)	87.8 ± 2.8 (190 ± 5)
Flow rate, engine coolant, L/min (gal/min)	57.9 ± 3.8 (15.3 ± 1.0)
Temperature, oil to bearings, °C (°F)	96.1 ± 2.8 (205 ± 5)
Temperature, inlet air to engine, °C (°F)	123.9 ± 2.8 (255 ± 5)
Temperature, exhaust, °C (°F)	573 ± 28 (1063 ± 50)
Pressure, fuel to injection pump, kPa (psi)	137.9 ± 13.8 (20 ± 2)
Pressure, exhaust, kPa (in. Hg Abs.)	106.7 ± 1.7 (31.5 ± 0.05)
Pressure, oil at jet cooling nozzle, kPa (psi) ^C	165.5 ± 13.8 (24 ± 2)
Pressure, oil to bearings maximum, kPa (psi) ^C	220.6 (32)
Pressure, air to engine, kPa (in. Hg Abs.)	179.0 ± 1.0 (53 ± 0.3)
Vacuum, crankcase, kPa (in. H ₂ O)	0.25 ± 0.12 (1.0 ± 0.5)
Humidity, air to engine, g/kg of dry air (grains/lb)	17.8 ± 1.7 (125 ± 12)
Flow rate, engine air, approximate m ³ /min (ft ³ /min) at 15.6 °C (60 °F), 101.3 kPa Abs. (14.7 psi Abs.)	0.2 (94)

^A Count test time from the moment the conditions in this table are obtained (30 min maximum are allowed for stabilization).

^B Only speed and fuel flow are controlled. Load is used as a verification of engine build and operation.

^C Oil pressure operating specifications apply only to 15W-40 oils. Attempt to maintain these limits for all oils. When oils other than 15W-40 oils fall outside these limits, explain these deviations from the limits in the comments section of the test report.

6.21.1.2 Exhaust temperature sensor depth: 65 mm ± 2 mm (2⁹/₁₆ in. ± 1/₁₆ in.)

6.22 Parts:

6.22.1 *Procurement of Parts*—Information concerning procurement of Caterpillar test engines and replacement parts and approval of equivalent parts substitutions allowed in this test method is obtained by contacting Caterpillar Inc.^{14,11} Other parts and their sources referred to throughout the procedure are found in the footnotes. Use all Caterpillar parts on a first-in-first-out basis.

6.22.2 All parts for the 1Y73 engine and the 1Y73 Conversion Kit that are nonconforming by reason of faulty manufacture should be discussed with the Engine System Technology Department (ESTD) at Caterpillar Inc.^{14,11}

6.22.2.1 The test labs should contact ESTD when they believe a part is nonconforming:

6.22.2.2 ESTD will determine if they want the part returned, or provide warranty without viewing the part.

6.22.2.3 If ESTD determines that the part is nonconforming without viewing the part, the test labs will be asked to return the part to their Caterpillar dealer. ESTD will contact the dealer with the information that the part is being returned and provide warranty for it.

6.22.2.4 If ESTD wants to view the part, they will issue a Return Goods Authorization Number (RGA) to the test lab and send the part and the form to Caterpillar Inc.^{15,11}

6.22.2.5 If ESTD determines that the part is nonconforming, they will contact the dealer for the test lab and have the dealer provide warranty.

6.22.2.6 A sample of the RGA Claim Form is shown in **Fig. 1**. It should include return goods authorization number, part name, hours on the part, part number, quantity, purchase order number, date purchased, test lab that purchased the part, contact person's name, phone, fax, and address, dealer's name that sold the part, and measurements or photographs, or both, to document the nonconformance.

6.23 *Instrumentation*, capable of meeting (or exceeding) the calibration tolerances, measuring resolutions, and maximum system time constants shown in **Tables 2-4**.

6.24 *Crankcase Paint*—Inspect crankcases regularly to ensure proper paint coating. Coat crankcases as necessary, using either of two approved coatings.^{16,11}

7. Reagents and Materials

7.1 *Fuel*—The specified test fuel is Haltermann Products 0.4 % Sulfur Diesel Test Fuel.^{17,11} All fuel shall meet the fuel specifications as shown in **Annex A3** and shall be referenced

¹⁴ Caterpillar Inc., Engine System Technology Department, P.O. Box 610, Mossville, IL 61552.

¹⁵ Caterpillar Inc., Tech Center TC-L, Wing 4, Room 405, 14009 Old Galena Rd., Mossville, IL 61552.

¹⁶ Crankcase paint in one gallon cans as Yellow Primer Paint Cat Part #IE2083A, Primer #A123590, Serial #BIM0115877, B.A.S.F. Part #U27TD005 is available from B.A.S.F. Coating and Cocorant Division, P.O. Box 1297, Morganton, NC 28655; and as Glyptal 1201 Red Enamel, Brownell Outlet, 84 Executive Avenue, Edison, NJ 08817.

¹⁷ Available from Howell Hydrocarbons and Chemicals, Inc., 1201 South Sheldon Road, P.O. Box 429, Channel View, TX 77530.

through the ASTM TMC. Approximately 1137 L (300 gal) are required for each test. Include the fuel analysis for the last batch used for the test in the final report. The fuel supplier provides the analysis. If more than one batch is used, note this in the comments section of the **Unscheduled Downtime & Maintenance Summary** form of the test report with the appropriate percentages of run time.

7.2 *Test Oil*—Approximately 30 L to 34 L (8 gal to 9 gal) of test oil are required for each test.

7.3 *Engine Coolant*, a mixture of 118 mL (4 fluid oz) Part Number 3P2044 coolant additive (Pencool 2000^{18,11}) per 4 L (1 gal) of mineral-free water. Mineral-free water is defined as having a mineral content no higher than 34.2 ppm (2 grains/gal) total dissolved solids. A fresh coolant mixture is used for each new test.

7.4 Cleaning Materials:

7.4.1 *Solvent*—Use only mineral spirits meeting the requirements of Specification **D235**, Type II, Class C for Aromatic Content (0 % to 2 %) by vol, Flash Point (142 °F/61 °C, min) and Color (not darker than +25 on Saybolt Scale or 25 on Pt-Co Scale). (**Warning**—Combustible. Health hazard.) Obtain a Certificate of Analysis for each batch of solvent from the supplier.

7.4.2 *Dispersant Engine Cleaner*—Use Dispersant Engine Cleaner^{19,11} (order by this name) in solution with mineral spirits where called for in the engine flush procedure.

7.4.3 *General Cleaning Agents*—Use sodium bi-sulfate (Na₂SO₄) and tri-sodium phosphate (Na₃PO₄) in solution with water in the cooling system flush procedure. (**Warning**—Eye and throat irritants; repeated exposure can cause dermatitis. Wear protective gloves, face mask, or chemical type goggles.)

8. Safety

8.1 The operating of engine tests can expose personnel and facilities to a number of safety hazards. It is recommended that only personnel who are thoroughly trained and experienced in engine testing should undertake the design, installation and operation of engine test stands. Each laboratory conducting engine tests should have its test installation inspected and approved by its safety department. Provide personnel working on the engines with the proper tools, be alert to common sense safety practices, and avoid contact with moving or hot engine parts. Guards should be installed around all external moving or hot parts. When engines are operating at high speeds, heavy duty guards are required and personnel should be cautioned against working alongside the engine and coupling shaft. Provide barrier protection for personnel. All fuel, oil lines, and electrical wiring should be properly routed, guarded, and kept in good order. Scraped knuckles, minor burns, and cuts are common if proper safety precautions are not taken. Safety masks or glasses should always be worn by personnel working on the engines, and no loose or flowing clothing should be worn near running engines.

¹⁸ Available directly from Nalco, 4639 Corona Drive, Suite 61, Corpus Christi, TX 78441.

¹⁹ Available from The Lubrizol Corporation, 29400 Lakeland Blvd., Cleveland, OH 44092.

RETURN GOODS AUTHORIZATION CLAIM FORM

RETURN GOODS AUTHORIZATION CLAIM FORM

Return Goods Authorization Number: _____.

Claim Date: _____.

Contact: Caterpillar Inc
Engine System Tech Dev.
P.O. Box 610
Mossville, II 61552
Phone: 309-578-2131
Fax: 309-578-6457
Attn: R.A. Riviere

Part Number / Quantity: _____ / _____.

Part Name / Hrs On Part: _____ / _____.

Date Part Purchased: _____.

Engine Serial Number: _____.

Test Lab

Name: _____.

Address: _____.

Contact Person's Name: _____.

Phone Number: _____.

Fax Number: _____.

Name of Dealer That Sold Part: _____.

INCLUDE DOCUMENTATION AND PHOTOS OF NONCONFORMING PART

FIG. 1 Return Goods Authorization Claim Form

8.2 Keep the external parts on the engine and the floor area around the engines clean and free of oil and fuel spills. In addition, keep working areas free of all tripping hazards. In case of injury, no matter how slight, first aid attention should be

applied at once and the incident reported. Personnel should be alert for leaking fuel or exhaust gas. Leaking fuel represents a

TABLE 2 Calibration Tolerances

Parameter	Tolerance	
Speed, r/min	2	
Load	NA due to differences within industry. TMC to verify each lab during visits.	
Fuel flow	Absolute error $\leq 0.125\%$	
Humidity	NA. Already specified. Checked during running conditions as outlined in the test procedure (see form attached)	
Temperatures	°C	°F
Coolant out	0.25	0.5
Coolant in	0.25	0.5
Oil to bearing	0.5	1.0
Intake air	0.5	1.0
Exhaust	1.0	2.0
Pressures		
Oil to bearing, psig	0.7 kPa	0.1
Oil to jet, psig	0.7 kPa	0.1
Inlet air, in Hg	0.3 kPa	0.1
Exhaust, in Hg	0.3 kPa	0.1
Fuel at filter housing., psig	0.7 kPa	0.1
Crankcase vacuum, in H ₂ O	0.02 kPa	0.1

fire hazard, and exhaust gas fumes are noxious. Containers of oil or fuel cannot be permitted to accumulate in the testing area.

8.3 Equip the test installation with a fuel shut-off valve designed to automatically cut off the fuel supply to the engine when the engine is not running. A remote station for cutting off fuel from the test stand is recommended. Provide suitable interlocks so that engine is automatically shut down when any of the following events occur: engine or dynamometer loses field current, engine overspeeds, exhaust system fails, room ventilation fails, or the fire protection system is activated. Consider an excessive vibration pickup interlock if equipment is operated unattended. Provide fixed fire protection equipment, and make dry chemical fire extinguishers available at the test stands. (**Warning**—Many ASTM tests use chemicals to flush engines between tests. Some of these chemicals require that personnel wear face masks, dust breathers, and gloves because exothermic reactions are possible. Provide emergency showers and face rinse facilities when handling materials.)

9. Preparation of Apparatus

9.1 Supplementary Service Information:

9.1.1 *Caterpillar Service Manual*—Engine service information not found in this test method may be obtained by referring to the Caterpillar Single Cylinder Oil Test Engine Service Manual (Form No. SENR2074) and parts manual SEBP1299.^{14,11}

9.1.2 *Pretest Maintenance Check List and Continuing Engine Inspection*—A recommended list of items that are checked or replaced at the intervals specified is shown in **Table 5**.

9.2 General Engine Inspection:

9.2.1 Perform a complete engine inspection every 10 000 test hours. This inspection is done to ensure that wearing surfaces, such as main bearings and journals, rod bearings and journals, camshaft bearings, and so forth, are within manufacturer's specifications. This inspection will terminate the current test stand calibration (if any). Recalibration is required any time the crank is removed for any purpose other than bearing replacement.

9.2.2 Maintain a complete record of all engine maintenance and measurements. Retain a description of inspection methods along with the maintenance records for review when requested.

9.3 *Intake Air System*—Prior to each stand calibration test, inspect the intake air barrel for rust and debris. This may be done through either of the pipe flanges, using a borescope or some other optical means. Remove any foreign material.

9.4 Cooling System:

9.4.1 Whenever visual inspection indicates the need, remove all mineral deposits and oil from the cooling system. Make the initial coolant charge at the start of the test with distilled or de-ionized water and a rust inhibitor (Penncol 2000) (see 7.3). The cooling system shall remain full during all shutdowns that do not require the cooling system to be drained.

9.4.2 Make any make-up coolant additions throughout the test with the same treated water solution. Monitor the cooling system visually at the glass or plastic tube in the 1Y504 water outlet line assembly. At any indication of vapor formation, the coolant will have a clouded appearance. Should this occur during a test, shutdown the engine and check for air leakage on the suction side of the water pump or combustion gas leakage in the cylinder head. No air is permitted in the system.

9.5 *Engine Cooling System Cleaning*—Clean the cooling system when visual inspection shows the presence of oil or grease, mineral deposits, or rust. Heads may be cleaned when either on or off the engine. Use the following procedure:

9.5.1 Operate the engine long enough to reach oil and water operating temperatures; drain the cooling system.

9.5.2 Fill the cooling system with a solution of 450 g (1 lb) commercial sodium bisulfate (Na₂SO₄) to 19 L (5 gal) of water; then run the engine at operating temperature for ½ h.

9.5.3 Drain and flush the engine with fresh water, and drain the water from the system.

9.5.4 Fill the cooling system with a solution of 450 g (1 lb) of tri-sodium phosphate (Na₃PO₄) to 38 L (10 gal) of water; operate the engine for 5 min to ensure complete mixing of the Na₃PO₄ solution with any material left from the previous flush.

9.5.5 Drain the engine, flush with clear water, and drain after flushing.

9.5.6 Disassemble the engine, and prepare for the next test.

NOTE 2—If the purpose of the system cleaning is to descale only, 9.5.4 and 9.5.5 can be omitted.

9.6 Instrumentation Calibration Requirements:

9.6.1 General Requirements:

9.6.1.1 Calibrate all facility read-out instrumentation used for the test immediately prior to commencing a test stand calibration. Instrumentation calibrations prior to subsequent stand calibration tests (that is, those that follow a failed or invalid first attempt) are at the discretion of the test laboratory. Make these calibrations part of the laboratory record (refer to **Tables 2-4** for specifications).

9.6.1.2 Calibrate on a yearly basis all temperature, pressure, flow, and speed measurement standards with instruments traceable to a national bureau of standards (for example, the National Bureau of Standards and Technology or its successor agency for labs operating in the United States). Maintain records of all calibrations for a minimum of two years.

TABLE 3 Operational Specifications, Measurement Resolution, and Reporting Resolution

Parameter	SI Specification				US Customary System (USCS) Specification			
	Units	Spec	Minimum Measurement Resolution	Round Values to the Nearest	Units	Spec	Minimum Measurement Resolution	Round Values to the Nearest
Speed	r/min	1800 ± 10	1	Whole number	r/min	1800 ± 10	1	Whole number
Power	kW	31.3			bhp	42		
BMEP	kPa	951			psig	138		
Fuel rate	kJ/min	6172 ± 53			Btu/min	5850 ± 50		
Fuel flow ^A	kg/h	8.13 ± 0.07	0.01	Hundredth	lb/h	17.92 ± 0.15	0.01	Hundredth
BSFC	kg/kWh	0.260			lb/bhp.h	0.427		
Humidity	g/kg	17.8 ± 1.7	0.1	Tenth	grains/lb	125 ± 12	1	Whole number
Oil weight	g	N/A	1	Whole number	lb	N/A	0.01	Hundredth
Temperatures								
Coolant out	°C	87.8 ± 2.8	0.1	Tenth	°F	190 ± 5	0.1	Tenth
Coolant in	°C	82.8	0.1	Tenth	°F	181	0.1	Tenth
Coolant Δ	°C	5 ± 1.0	0.1	Tenth	°F	9 ± 2	0.1	Tenth
Oil to bearing	°C	96.1 ± 2.8	0.1	Tenth	°F	205 ± 5	0.1	Tenth
Inlet air	°C	123.9 ± 2.8	0.1	Tenth	°F	255 ± 5	0.1	Tenth
Exhaust	°C	573 ± 28	1	Whole number	°F	1063 ± 50	1	Whole number
Pressures								
Oil to bearing ^B	kPa	220.6 Max			psig	32 max		
Oil to jet ^B	kPa	165.5 ± 13.8	0.1	Tenth	psig	24 ± 2	0.1	Tenth
Inlet air (ABS)	kPa	179 ± 1	0.1	Tenth	in. Hg	53.0 ± 0.3	0.1	Tenth
Exhaust (ABS)	kPa	106.7 ± 1.7	0.1	Tenth	in. Hg	31.5 ± 0.5	0.1	Tenth
Fuel at filter housing.	kPa	137.9 ± 13.8	0.1	Tenth	psig	20 ± 2	0.1	Tenth
Crankcase vac	kPa	0.25 ± 0.12	0.01	Hundredth	in. H ₂ O	1 ± 0.5	0.1	Tenth
Flows								
Coolant flow	L/min	57.9 ± 3.8	0.1	Tenth	gal/min	15.3 ± 1.0	0.1	Tenth

^A Fuel flow spec is based on the high heating value of 19,590 Btu/lb at an A.P.I. gravity of 35. Fuel spec is 33 to 35 A.P.I. gravity.

^B Oil pressure operating specifications apply only to 15W-40 oils. Attempt to maintain these limits for all oils. When oils other than 15W-40 oils fall outside these limits, explain these deviations from the limits in the comments section of the test report.

TABLE 4 Maximum Allowable System Time Constants

Measurements	
Speed	3.0 s
Fuel Flow	73.0 s
Temperatures	
Coolant Out	3.0 s
Coolant In	3.0 s
Oil to Bearings	3.0 s
Intake air	3.0 s
Exhaust	3.0 s
Pressures	
Oil to Bearings	3.0 s
Oil to Jet	3.0 s
Intake Air	3.0 s
Exhaust	3.0 s
Fuel at Filter	3.0 s
Crankcase Vac.	3.0 s

9.6.2 Specific Humidity Requirements:

9.6.2.1 Calibrate the primary laboratory humidity measurement system during the first 24 h of each individual stand calibration test using a chilled-mirror dew point hygrometer with an accuracy of at least ±0.55 °C at 24 °C (±1 °F at 75 °F) dew point. The calibration consists of a series of *paired* comparison measurements between the primary system and the chilled-mirror dew point hygrometer. The comparison period lasts from 20 min to 2 h with measurements taken at 1 min to 6 min intervals, for a total of 20 paired measurements. The measurement interval should be appropriate for the time constant of the humidity measuring instruments.

9.6.2.2 The location of the hygrometer tap is shown in [Fig. A1.28](#). The sample line may require insulation to prevent dropping below dew point temperature and shall not be hygroscopic. The flow rate shall be verified to be within the equipment manufacturer’s specification.

9.6.2.3 All measurements taken with the dew point hygrometer are at atmospheric pressure and corrected to standard conditions (101.12 kPa [29.92 in. Hg]) using the perfect gas law or [Table X1.1](#) to [Table X1.9](#) in [Appendix X1](#). Compute the difference between each pair of measurements and use to form a mean and standard deviation. The absolute value of the mean difference shall not exceed 0.648 g (10 grains), and the standard deviation shall be less than or equal to 0.324 g (5 grains). Both of these requirements shall be met for the primary humidity measurement system to be considered calibrated. If either of these requirements cannot be met, the laboratory should investigate the cause, make repairs, and recalibrate. Maintain the calibration data for two years.

9.6.2.4 *Recommended Practice*—Install drain taps at the low points of the combustion air system and keep open during shut-down and warm-up.

9.6.3 Specific Coolant Flow Requirements:

9.6.3.1 As a calibration standard, each test lab is required to maintain at least one Barco venturi flow meter configured as shown in [Fig. A1.8](#) and described in [6.16](#). On a yearly basis, calibrate this Barco (with its inlet and outlet piping) with an instrument traceable to a national bureau of standards (for example, the National Bureau of Standards and Technology or

TABLE 5 Pretest Maintenance Check List^A and Continuing Engine^B Inspection

Item to be checked	Remarks	
Fuel injection pump adjusting screw (2F8337)	Inspect before each test. Replace as necessary.	
Fuel injection pump	Check pump plunger sector gear for tooth wear—general condition of pump (visual); replace pump as necessary.	
Fuel injection valve	Install new before each test. Inspect fuel injection line orifice (both ends) for correct diameter, 1.57 mm (0.062 in.) minimum.	
Fuel injection timing	3.81 mm ± 0.127 mm (0.150 in. ± 0.005 in.) lift, BPC at 8° BTC.	
Injection pump inlet seal (2M4453)	Install new before each test.	
Filter-fuel system	Install when fuel pressure cannot be held within test limits.	
Cylinder head	New (calibration test only) or reconditioned head for each test. Measure and record valve head and stem projection. Measure prechamber orifice diameter (7.59 mm to 7.64 mm [0.299 in. to 0.301 in.]).	
Cylinder head gasket (1Y7960)	Install new before each test.	
Piston cooling jet	Inspect for plugging and proper positioning before each test; use aiming guide. Verify piston-cooling jet clearance.	
Water pump and fuel transfer pump belts	Inspect and adjust as necessary. (Measure deflection at point midway between pulleys - water and fuel.)	
	Belt deflection	Force
	19.05 mm	111 N
	(0.75 in.)	(25 lb)
Fuel pressure	138 kPa (20 psi)	
Water flow	58.0 L/min (15.3 gal/min)	
Crankcase stud seal (1Y2310)	Inspect and replace as required. Install with taper down.	
Valve tappets	Zero lash + ½ turn hydraulic lash adjusters. ^C	
Piston pin	Clearance in rod pin bushing—0.051 mm (0.002 in.) maximum	
Fuel pump rack and rack control rod, gov. button, lever, and sliding sleeve	Check rack for tooth wear—rack control rod for worn ball and socket joints and loose nuts and washers. Gov. button and lever for wear and free movement, sliding sleeve for free movement, bearing condition, and gov. wt. contact and wear.	
Valve rotators	Inspect for proper operation at start of test and end of test.	
Leaks	Repair immediately upon detection, particularly fuel, oil, air, exhaust, and coolant.	

^A This check list is made to cover the maintenance to be performed before and during each test. Included are those parts, in addition to the piston rings and liner, to be installed new at the beginning of each test. Replace all gaskets that are disturbed during such disassembly and assembly that takes place between tests or at intermediate inspections. Carefully inspect seals before their reuse.

^B ENGINE: 1Y73 130 mm (5.125 in.) bore, 165 mm (6.5 in.) stroke.

^C Leakdown time 8 s to 45 s for 3.175 mm (0.125 in.) plunger travel under a 22.68 kg (50 lb) load and filled with kerosene having a viscosity of 35 sus at 21.1 °C (70 °F).

its successor agency for labs operating in the United States). The inlet and outlet piping shall remain with this Barco assembly.

9.6.3.2 During the break-in prior to each calibration test, place this calibrated Barco assembly in the standard mounting position. Adjust the coolant flow bypass valve until the readout equipment being used registers the differential pressure that corresponds to 57.9 L/min (15.3 gal/min) for this calibrated Barco assembly.

9.6.3.3 After break-in, replace the calibrated Barco assembly with the stand's running Barco assembly. *Do not re-adjust the coolant flow bypass valve.* Maintain whatever differential pressure is registered with the stand Barco at this point throughout the duration of the test. Test all non-reference oils with this stand Barco assembly run at this differential pressure. If desired, adjust any readout equipment to make this differential pressure correspond to 57.9 L/min (15.3 gal/min).

9.7 *Engine Crankcase Cleaning*—Flush the engine prior to each new test. The objective is to remove all deposits from all surfaces of all engine cavities prior to each test. In some instances, extra cleaning may be required. A finger-wiping check may be made on less accessible engine surfaces from time-to-time to determine if the engine is clean.

9.8 *Additional Oil Filter*—Install a full-flow paper element oil filter in the flushing pump unit to remove engine wear

particles during engine flush. Such particles have been known to cause piston scuffing during subsequent testing.^{20,11}

9.9 *Flushing Procedure Components*—Conduct the engine flushing procedure with the components shown in Fig. A1.12 through Fig. A1.19 (the design for mobilizing the flushing pump arrangement, Fig. A1.13, is optional). Fig. A1.17 (Views A and B) illustrates the use of the flushing components.

9.10 *Flushing Procedures*—Use the following flushing procedure:

9.10.1 Rotate the crankshaft until the top end of the connecting rod is below the cylinder block bore in the top of the crankcase. Install the poly(methyl methacrylate) (PMMA) or clear plastic cover (Fig. A1.12 on the top surface of the crankcase, as shown in Fig. A1.17 (View A).

9.10.2 *For First Stage Flushing with Mineral Spirits:*^{21,11}

9.10.2.1 Install a clean 1Y5700 element in both the engine and flushing pump oil filter housings.

9.10.2.2 Connect the flushing pump (Fig. A1.13) outlet hose to the engine oil cooler drain location.

²⁰ TEI CLR engine oil filter housing #2418 and filter element #3105 have been found satisfactory for this use. Available from Test Engineering, Inc., 12758 Cimarron Path, Suite 102, San Antonio, TX 78429.

²¹ Available from UNOCAL Chemicals Division, 7010 Mykawa Street, Houston, TX 77033.

9.10.2.3 Remove breather assembly 1Y2592 (top portion of side cover assembly) and clean separately by soaking in mineral spirits. Air-dry.

9.10.2.4 Insert the 1Y5 rocker shaft oil line in the center opening of the clear plastic cover (see Fig. A1.12).

9.10.2.5 Place the flushing pump inlet line in a clean supply tank (sample location illustrated in Fig. A1.13) containing 7.6 L (2 gal) of mineral spirits. Open the crankcase drain, start the flushing pump, and run this flush material through the engine into a drain pan one time. *Do not recirculate.*

9.10.2.6 Close the crankcase drain and connect the flushing pump inlet line to the crankcase drain.

9.10.3 *For Second Stage Flushing and Recirculating with Cleaning Mixture*—Mix 1.9 L (½ gal) of dispersant engine cleaner (see Footnote 19) with 5.7 L (1 ½ gal) of mineral spirits to obtain 7.6 L (2 gal) of flushing solution. Add this mixture to the crankcase.

9.10.3.1 Connect the flushing pump outlet line to the engine oil cooler drain location. Open the crankcase drain valve, start the flushing pump, and circulate the flushing solution through the engine for approximately 15 min. Turn off the pump. (Do not drain the flushing solution from the crankcase.)

9.10.3.2 Close the oil cooler drain valve, disconnect the flushing pump outlet hose from the oil cooler drain location, and connect to the crankcase sprayer (Fig. A1.14).

9.10.3.3 Remove the 1Y5 oil line from the cover hole, insert the crankcase sprayer through the opening in the PMMA cover. Start the flushing pump, and spray the interior of the crankcase by slowly moving the sprayer around and into all accessible areas of the crankcase (see Fig. A1.17, View A) for approximately 10 min. Turn off the pump. (Do not drain the flushing solution from the crankcase.)

9.10.3.4 Remove the ½ in. pipe plug from the modified 1Y1990 governor housing cover (see Fig. A1.15). Insert the crankcase sprayer (Fig. A1.14) through the opening in the governor housing cover, start the pump, and spray the interior of the governor housing for approximately 10 min. Turn off the pump. (Do not drain the flushing solution from the crankcase.)

9.10.3.5 Remove the oil filler spout assembly from the front of the crankcase, and install the front cover sprayer (see Fig. A1.16) as shown in Fig. A1.17.

9.10.3.6 Connect the flushing pump outlet to a 64 mm × 13 cm (½ in. × 5 in.) pipe on the front cover sprayer (see Fig. A1.16). Start the flushing pump, and spray the interior of the front cover for approximately 10 min. Drain the crankcase, governor, oil filter, and oil cooler; and discard the flushing solution.

9.10.4 *Using Mineral Spirits*—Repeat 9.10.2.4 through 9.10.2.6 until the mineral spirits discharge is clean. (Three to four flushes with mineral spirits are usually sufficient to remove all traces of the flushing solution from the engine.) Drain the mineral spirits from the crankcase, governor housing, oil filter, and oil cooler.

9.10.5 *Test Oil Flushing*—When engine is to be used immediately:

9.10.5.1 Prepare for the flush with the test oil by blocking off the 1Y5 oil line to the rocker arm shaft and installing the

6.4 mm (¼ in.) fitting (see Fig. A1.18) on the open end of the line. Close all drain openings.

9.10.5.2 Using the flushing pump, add 4.7 L (5 qt) of test oil to the engine crankcase through the engine oil cooler.

9.10.5.3 Connect the flushing pump outlet to the engine oil cooler drain location. Start the flushing pump, and force any mineral spirits in the system out the crankcase drain. After the mineral spirits have been forced out of the system, connect the inlet line of the flushing pump to the crankcase drain. Install the dummy piston (reference service manual SENR2074^{14,11}) and the assembled cylinder liner and block assembly or the alignment fixture specified in Fig. A1.19. Re-install the oil filler spout and pipe plug in the modified governor housing cover (see Fig. A1.15).

9.10.5.4 Open the crankcase drain and start the flushing pump. Set and maintain the oil pressure at 207 kPa (30 psi). With the starter or dynamometer, turn the engine over for 1 min. Turn off the pump, and drain all oil from the engine crankcase, governor housing, oil filter, and oil cooler. Discard the oil drained.

9.10.5.5 Charge the engine again with 4.7 L (5 qt) of test oil, and repeat the procedure described in 9.10.2. During this flush, check the alignment of the piston cooling nozzle and adjust, if necessary. Before any such adjustment, make sure that the oil-stream condition has stabilized, that is, a steady stream of oil impinges the piston indicating that the oil pressure has attained a constant value. After draining the oil, install a clean element in the engine oil filter housing. Reinstall crankcase breather assembly 1Y2592.

9.10.6 *Test Oil Flushing*—When the test oil is not available and the engine test start will be delayed: follow the steps up to 9.10.5.2. However, in 9.10.5.2, use buildup oil^{22,11} in place of test oil. When a test oil is scheduled for the engine, perform the following steps:

9.10.6.1 Connect the flushing pump outlet to the engine oil cooler drain location. Using the flushing pump, add 4.7 L (5 qt) of test oil to the engine crankcase through the engine oil cooler. Start the flushing pump, and force the build-up oil out the crankcase drain. After the build-up oil has been forced out of the system, connect the inlet line of the flushing pump to the crankcase drain. Set and maintain oil pressure at 207 kPa (30 psi). By hand, turn the engine five revolutions, and continue to run the pump for 4 min. Turn off the pump, and drain all oil from the engine crankcase, governor housing, oil filter, and oil cooler. Discard the oil drained.

9.10.6.2 Repeat the procedure described in 9.10.6.1. After draining the oil, install a clean element in the engine oil filter housing and prepare the engine for break-in.

9.10.7 An instruction sheet for technician use during the engine cleaning is shown in Fig. 2.

9.11 *Piston Cleaning Preparation*—Clean new pistons using the following procedure before the installation of rings and final installation into the engine:

²² Non-compounded oil ISO VG (SAE 20) (see Classification D2422) is available from lubricant marketers. One supplier is Mobile Corporation. The Mobile product is designated EF-411 and is available from Mobile Corporation, Illinois Order Board, P.O. Box 66940, AMF O'Hare, IL 60666. Ask for P/N 47503-8.

FLUSH FLUID PROCEDURE PUMP CONNECTION FLUSHING TIME IN MINUTES

	<u>INLET</u>	<u>OUTLET</u>	Engine Oil	Crank Case	Governor Housing	Front Cover Line
1. Stoddard-2 gal (7.6 L) (Note: Remove crankcase breather 1Y2592 from engine and wash in solvent until clean. Air dry)	Solvent tank	Oil cooler drain	5			
2. Cleaning mixture: Eng. cleaner - 1/2 gal (1.9 L) Stoddard - 1 1/2 gal (5.7 L)	Crankcase drain Crankcase drain Crankcase drain	Oil cooler drain Crankcase sprayer Front cover sprayer	15	10	10	10
3. Drain Stoddard from crankcase, governor housing, oil filter and oil cooler Solvent flush A Stoddard - 2 gal (7.6 L)	Crankcase drain Crankcase drain Crankcase drain	Oil cooler drain Crankcase sprayer Front cover sprayer	15	10	10	10
4. Drain Stoddard from crankcase, governor housing, oil filter and oil cooler. Solvent flush B Stoddard - 2 gal (7.6 L)	Crankcase drain Crankcase drain Crankcase drain	Oil cooler drain Crankcase sprayer Front cover sprayer	15	10	10	10
5. Drain Stoddard from crankcase, governor housing, oil filter and oil cooler. Solvent flush C Stoddard - 2 gal (7.6 L)	Crankcase drain Crankcase drain Crankcase drain	Oil cooler drain & bh Crankcase sprayer Front cover sprayer		10	10	10
6. Drain Stoddard solvent from crankcase, governor housing, oil filter, oil cooler - <u>IF SOLVENT CLEAN GO TO STEP 8</u> Extra solvent flushes Stoddard - 2 gal (7.6 L)	Crankcase drain Crankcase drain Crankcase drain	Oil cooler drain Crankcase sprayer Front cover sprayer	15	10	10	10
7. GO BACK TO STEP 6						
8. Drain crankcase, governor housing, oil filter, oil cooler - <u>CLOSE DRAINS & 1Y5 LINE</u> Install dummy piston, cylinder clock, liner, oil filter spout, governor housing cover.						
9. Test oil - 5 qt (12.9 L)	Crankcase drain	Oil cooler drain	5 (including 4 min with engine motored)			
10. DRAIN CRANKCASE, GOVERNOR HOUSING, OIL FILTER, OIL COOLER						
11. Test oil - 5 qt (18.9 L)	Crankcase drain	Oil cooler drain	5 Align piston jet - drain - Build for test			

FIG. 2 Caterpillar Engine Cleaning Procedures

9.11.1 Spray with mineral spirits and dry with compressed air. (**Warning**—High concentration of vapors should be avoided. Use vented hood, face shield, gloves (same precautions as for gasoline).)

9.11.2 Using a lint-free cloth, wipe clean the entire piston with pentane, paying special attention to ring groove and land areas. Allow the piston to air dry.

9.11.3 Wipe the piston with Mobil EF-411^{22,11} before final installation into the engine.

9.12 Cylinder Head:

9.12.1 *Valve Guide Bushings*—Remove and replace the 1Y448 and 1Y449 valve guide bushings with 1Y457 valve guide bushings (inlet) and 1Y469 valve guide bushing (exhaust). The new guides have the I.D. (inside diameter) threaded and require either reaming (see 9.12.1.2) or honing (see 9.12.1.3) after installation in the cylinder head. The required procedure is as follows:

9.12.1.1 Install the 1Y469 and 1Y457 bushings into the bores in the cylinder head.

9.12.1.2 Ream the I.D. of both bushings in successive steps with the following reamers as required to obtain the clearances listed in 9.12.1.4: 12.52 mm (0.4930 in.), 12.55 mm (0.4940 in.), 12.57 mm (0.4950 in.), 12.59 mm (0.4955 in.), 12.60 mm (0.4960 in.), and 12.61 mm (0.4965 in.).

9.12.1.3hone valve guide I.D. by using mandrel mounted honing stones.^{23,11} A continuous flow of honing oils is required. Turn the mandrel at slow speed (300 r/min to 400 r/min) until the final size, as listed in 9.12.1.4 is obtained. In general, honed guides produce more uniform stem-to-guide clearances, resulting in longer service life of valves and guides.

9.12.1.4 The reamed stem-to-guide clearance shall be 0.013 mm to 0.051 mm (0.0005 in. to 0.0020 in.). The honed stem-to-guide clearance shall be 0.025 mm to 0.051 mm (0.0010 in. to 0.0020 in.). All measurements shall be made using a direct reading dial bore gauge in the guide and micrometer on the valve stem. Valve stem drag shall not exceed 26 N (6 lb).

(1) Usual final size for intake guide: 12.59 mm or 12.60 mm (0.4955 in. or 0.4960 in.).

(2) Usual final size for exhaust guide: 12.57 mm or 12.59 mm (0.4950 in. or 0.4955 in.).

9.12.1.5 Thoroughly clean the reamed valve guide bushing with mineral spirits or hot water, detergent, and stiff brush.

9.12.1.6 Grind the valve seats and faces in accordance with the dimensions for the 1Y73 engine as specified in the Caterpillar, Inc. Service Manual for Single Cylinder Oil Test Engine for Diesel Lubricants, Form No. SENR2074.^{14,11}

²³ Parts P-180 (Honall Head and Driver Group), PK-16-A (Adapter), JK 16-495AS (Mandrel), LN 3703 (Stone Retainer), K16-J68 (Stones), S-495 (Truing Stone), MAN-845-5 (Honing Oil), P-300 (Dial Bore Gauge), and P-500 (Gauge Probe) are available from Valve Guide Honing & Measurement Equipment, Sunnen Products Company, 7910 Manchester Road, St. Louis, MO 63143. Ringmaster Set 067-30-010-3 (used to set P-300 gauge) available from Ralmike's Tool-A-Rama, 4505 South Clinton Avenue, South Plainfield, NJ 07080. D-30LR-4 Air Drill-400r/min available from Stanley Tools Division, 700 Beta Drive, Cleveland, OH 44141. Pd-3-3/8 Air Drill and Small Parts Washers available from Local Distributors of Snap-On Tools, Kenosha, WI.

9.12.1.7 Thoroughly clean the entire cylinder head and valves after grinding. Prelube the valve stems and guides with Mobil EF-411.^{22,11}

9.12.1.8 Insert a rubber O-ring (p/n 8F9206) into the 3H5867 valve spring retainer for all 1M-PC tests. Inspect this O-ring for hardness or cracking during cylinder head reconditioning and replace as necessary.

9.12.2 *Precombustion Chamber Inspection and Maintenance*—Maintain the orifice diameter of the precombustion chamber, Part Number 6H1528, at 7.620 mm \pm 0.025 mm (3.300 in. \pm 0.001 in.). Inspect and measure the orifice prior to installation of the cylinder head on the engine at the start of the 1M-PC test method. Any measurement that is out of the 7.620 mm \pm 0.025 mm (0.300 in. \pm 0.001 in.) diameter limit or shows any indication of ovality requires the replacement of the precombustion chamber.

9.13 *Fuel Nozzle*—Inspect the nozzle tip for carbon build-up and deformed surfaces, and replace questionable nozzles. Check the valve opening pressure before each test. Refer to the service manual for additional information.

9.14 *Measurement*—Measure the piston, rings, cylinder liner, and fuel timing before the start and at the completion of the test. Use a new piston, ring set, and cylinder liner for each new test. Measure and report compression ratio at the start of the test.

9.14.1 *Initial Cylinder Liner Measurements*—Assemble the cylinder head, block, and liner with specified stud nut torque.

9.14.1.1 Measure the 1Y3590, 1Y3995, or 5H5657 liner in both transverse and longitudinal directions relative to the crankshaft to ensure that the out-of-round and taper conditions are within specified tolerances. Take measurements from underneath at 25 mm (1 in.) intervals for 23 cm (9 in.), starting 25 mm (1 in.) from the top of the liner.

9.14.1.2 Determine the out-of-round condition for each 25 mm (1 in.) interval: It shall not exceed 0.038 mm (0.0015 in.).

9.14.1.3 The taper measurement compares the diameters from 25 mm (1 in.) to 23 cm (9 in.) for both transverse and longitudinal positions; the maximum difference shall not exceed 0.051 mm (0.0020 in.).

9.14.1.4 Measure liner surface finish. Record all measurements on the Liner Measurements form of the test report.

9.14.2 *Post Test Wear Measurements for Liner Step Wear*—At the end of the test, determine the liner wear step in both transverse and longitudinal directions by using a surface profile measurement. Remove deposits on the liner above the piston ring travel. Take transverse and longitudinal measurements at the wear step location approximately 20 mm to 25 mm (0.75 in. to 1 in.) from the top of the liner at four locations. Record the measurements as liner wear on the Liner Measurements form of the test report.

9.14.3 *Ring End Gap*—Determine wear on the rings by measuring the gap width before and after the test with the ring confined in a 13.02 cm (5.125 in.) inside diameter ring gauge. Remove all deposits from the end of the rings after the deposit inspection and before the final ring gap measurements. Record

the difference between these two measurements as ring gap increase or wear on the Ring Measurements form of the test report.

9.14.4 Ring Side Clearance:

9.14.4.1 Before and after the test, measure the piston ring side clearance of all rings. Make the after-test measurements before the rings are removed from the piston and with the accumulated deposits in place. Record all measurements on the Ring Measurements form of the test report. Measure side clearances as follows:

(1) Insert thickness (feeler) gauge underneath the piston ring.

(2) Slide gauge around the piston while holding ring in gently at the point of measurement to determine the minimum and maximum clearance to the nearest 0.013 mm (0.0005 in.)

(3) Use of gauge requires firm but smooth horizontal pull. If gauge movement is not firm or requires undue stress to move it, adjust the thickness up or down as required.

(4) Repeat 9.14.4.1 (1), (2), and (3), being careful not to force ring or gauge against any deposit build up.

9.14.4.2 Calculate ring side clearance loss from:

$$\text{Max}_{\text{before}} - \text{Max}_{\text{after}} \text{ or } \text{Min}_{\text{before}} - \text{Min}_{\text{after}} \quad (1)$$

whichever is greater. Report zero in cases where loss of side clearance is less than zero.

9.14.4.3 Side clearance specification for new parts is:

(1) Top ring, 0.185 mm maximum (0.0073 in.) to 0.114 mm minimum (0.0045 in.)

(2) Two intermediate rings, 0.122 mm maximum (0.0048 in.) to 0.076 mm minimum (0.0030 in.)

(3) Oil ring, 0.076 mm maximum (0.0030 in.) to 0.038 mm minimum (0.0015 in.)

9.14.5 Compression Ratio:

9.14.5.1 Determine the compression ratio before starting the test. Essential to measuring compression ratio is piston-to-head clearance. Determine this dimension by using 2.41 mm to 2.67 mm (0.095 in. to 0.105 in.) diameter lead shot. These lead pieces are held on the top of the piston with light grease. The location pattern for the lead shot is shown in Fig. A1.20. With the piston approximately halfway up on the stroke the cylinder head is installed and torqued to the standard torque specifications. Turn the engine over top center by hand, remove the head and block assembly, and measure the thickness of the lead shot to obtain the piston-to-head clearance. The average piston-to-head clearance shall measure 1.30 mm \pm 0.127 mm (0.051 in. \pm 0.005 in.).

9.14.5.2 Use multiple block gaskets (1Y3698) to adjust clearance. If the piston-to-head measurement exceeds the tolerance specification, check the crankshaft main and rod journals, connecting rod and main bearings, piston pin, and bushing for excessive wear. If these dimensions are not all within specifications, consult Caterpillar before any standard 1M-PC test is started.

9.14.6 Piston Ring Gap Location—Install the piston in the engine in accordance with standardized ring gap location. Use the 1Y3589 piston and 1Y3588 ring set. See Fig. A1.22 for ring gap locations.

10. Procedure

10.1 *Engine Break-in*—Weigh in 4. kg8 \pm 0.11 kg (10.6 lb \pm 0.25 lb) of oil. For non-reference tests, take a 240 mL (8 oz) sample of the oil for use in the 40 °C initial viscosity measurement reported on the Operational Summary form of the test report. Perform break-in per Table 6. When the cooldown is complete and the engine is still hot, drain the crankcase, governor housing, oil cooler, and lubricating oil filter housing for 30 min. Use the drain cocks provided.

10.2 Pre-Test Preparations:

10.2.1 Weigh 4.8 kg \pm 0.11 kg (10.6 lb \pm 0.25 lb) of oil into the engine.

10.2.2 Perform warm-up as described in 10.3.

10.3 Warm-up Procedure:

10.3.1 Perform Steps 1, 2, and 3 of Table 7 for all starts except break-in.

10.3.2 When finished with warm-up, turn on inlet air heating elements and bring stand to test conditions (see Table 1).

10.4 *Operating Conditions*—During this test, target all controlled parameters to the specified mean. Run the engine continuously for 120 h at the conditions shown in Table 1.

10.5 Periodic Measurements:

10.5.1 Except engine air flow rate, record the parameters listed in Table 1 hourly as snapshots. Record values as found **before** adjustments are made to correct to the specification mean. These recorded values show the engine conditions actually present at each hour of the test. (They are not averages computed from data logged during the test hour.) Make corrections to each hourly humidity reading for nonstandard barometric conditions, using additive correction factors derived from the perfect gas law equation (see 9.6.2).

10.5.2 Also record and report the following data:

10.5.2.1 Crankcase blowby, m³/h (ft³/h), once each 12 h period. (A minimal increase in crankcase pressure is allowed

TABLE 6 Break-in Conditions

	Step ^A				
	1	2	3	4	5 ^B
Speed, r/min	1000	1000	1600	1800	1800 \pm 10
		7.5	17.1	24.6	31.3
Load, kW (bhp)	Idle	(10)	(23)	(33)	(42)
Fuel rate	1.36	2.27	4.72	6.88	8.13 \pm 0.07
kg/h (lb/h)	(3.0)	(5.0)	(10.42)	(15.16)	(17.92 \pm 0.15)
Bearing oil temp.				82.0	96.1 \pm 2.8
°C (°F)				(180)	(205 \pm 5)
Jet pressure ^C	158.6	158.6	158.6	165.5	165.5
kPa (psi), min.	(23)	(23)	(23)	(24)	(24)
Water oil temp.			71.0	71.0	87.8 \pm 2.8
°C (°F)			(160)	(160)	(190 \pm 5)
Air inlet temp.				76.7	123.9 \pm 2.8
°C (°F)				(170)	(255 \pm 5)
Air inlet pressure	118.0	118.0	135.0	135.0	179 \pm 1
kPa (in. Hg Absolute)	(35.0)	(35.0)	(40.0)	(40.0)	(53 \pm 0.3)
Time, minutes	5	5	10	20	20

^A Follow standard cool down procedure (see Table 8).

^B Measure blowby over last 15 min of the break-in record.

^C Oil pressure operating specifications apply only to 15W-40 oils. Attempt to maintain these limits for all oils. When oils other than 15W-40 oils fall outside these limits, explain these deviations from the limits in the comments section of the test report.

TABLE 7 Warm Up

	1	2	3
Speed, r/min	1000	1000	1600
		7.5	17.1
Load, kW (bhp)	Idle	(10)	(23)
Fuel rate	1.36	2.27	4.72
kg/h (lb/h)	(3.0)	(5.0)	(10.42)
Jet pressure ^A	158.6	158.6	158.6
kPa (psi), min	(23)	(23)	(23)
Water out temp.			71.0
°C (°F)			(160)
Air inlet pressure	118.0	118.0	135.0
kPa (in. Hg absolute)	(35.0)	(35.0)	(40.0)
Time, min	5	10	15

^A Oil pressure operating specifications apply only to 15W-40 oils. Attempt to maintain these limits for all oils. When oils other than 15W-40 oils fall outside these limits, explain these deviations from the limits in the comments section of the test report.

for a time period no greater than 4 min when switching from a normal operating system to the blowby measuring system.)

10.5.2.2 Engine load (should be approx. 31.3 kW or 42 bhp).

10.5.2.3 The weight of all oil added and drained and the engine hours at that time.

10.5.2.4 Document instances of missing or bad test data in the comments section of the Unscheduled Downtime and Maintenance Summary form of the test report. If a test has greater than 4-h data acquisition on any controlled parameter, the test is operationally invalid. Note any alternate method of data acquisition in the comment section of the Unscheduled Downtime and Maintenance Summary form of the test report.

10.6 *Engine Oil Level*—With the bayonet oil level gauge housing lowered, use the following procedure for measuring the crankcase oil level:

10.6.1 Withdraw the bayonet gauge and wipe free of oil.

10.6.2 Insert the bayonet gauge with the numerals facing the operator.

10.6.3 Count off 5 s.

10.6.4 Withdraw the bayonet gauge and read the oil level.

10.7 *Oil Addition Procedure*—Use the following steps when making oil additions:

10.7.1 At the end of the run-in, drain all the engine oil for 30 min and weigh in $4.8 \text{ kg} \pm 0.11 \text{ kg}$ ($10.6 \text{ lb} \pm 0.25 \text{ lb}$) of fresh oil.

10.7.2 During the first hour of the test, when the oil temperature reaches $96 \text{ }^\circ\text{C} \pm 2.8 \text{ }^\circ\text{C}$ ($205 \text{ }^\circ\text{F} \pm 5 \text{ }^\circ\text{F}$), record the crankcase level as the *Full Mark*.

10.7.3 Calculate the following levels:

10.7.3.1 *Drain Level* is two units below the *Full Mark*.

10.7.3.2 *Low Level* is two and one-half units below the *Full Mark*.

10.7.3.3 *Emergency Add Level* is three units below the *Full Mark*.

10.7.4 At the end of each 12 h period, check the crankcase oil level and perform the following:

10.7.4.1 If the oil level is above the *Full Mark*, drain to a level of *Drain Level* and weigh in $0.8 \text{ kg} \pm 0.22 \text{ kg}$ ($1.76 \text{ lb} \pm 0.05 \text{ lb}$) of fresh oil.

10.7.4.2 If the oil level is between the *Full Mark* and the *Drain Level*, drain oil from the engine until the oil level is at the *Drain Level*. Add $0.8 \text{ kg} \pm 0.22 \text{ kg}$ ($1.76 \text{ lb} \pm 0.05 \text{ lb}$) of fresh oil.

10.7.4.3 If the oil level is between *Drain Level* and *Low Level*, add $0.8 \text{ kg} \pm 0.22 \text{ kg}$ ($1.76 \text{ lb} \pm 0.05 \text{ lb}$) of fresh oil.

10.7.4.4 If the oil level is below the *Low Level*, add enough oil to the engine to bring it up to the *Full Mark*.

10.7.5 If the oil level falls below the *Emergency Add Level* at any time during the test, add $0.8 \text{ kg} \pm 0.22 \text{ kg}$ ($1.76 \text{ lb} \pm 0.05 \text{ lb}$) of fresh oil.

10.8 *Cool-Down Procedure*—Except for emergency (uncontrolled) stops, use the following procedure prior to all engine shutdowns including the break-in: Stop counting test time at the start of Stage 3 in **Table 8**. Turn off all heater elements and let air temperature cool normally.

10.9 Shutdowns:

10.9.1 For all occurrences, report the test hours and length of time down on the Unscheduled Downtime and Maintenance Summary. If the cool-down procedure is not used, identify the shutdown as an emergency shutdown. In the event of an emergency shutdown, maintain a 2 h off-test condition for engine cooling before restarting. Maximum allowable downtime for the duration of the test is 125 h. Minimize the total downtime of the test. To protect deposits, rotate the engine to top dead center of the compression stroke during shutdowns.

10.9.2 An excessive number of emergency or regularly scheduled shutdowns that reasonably could have been prevented will influence test acceptability. Pre-arrange schedules for tests with planned shutdowns (for reasons other than those normally permitted) with the TMC.

10.10 *Fuel System*—Bleed the fuel lines free of air prior to each test or if fuel is drained from the engine fuel system for any reason.

10.11 *Brake Specific Oil Consumption (BSOC) Calculation*—Calculate the BSOC for the test as follows:

$$\frac{(\text{sum of adds}) - (\text{sum of drains})}{(120 \times \text{average engine power})} \quad (2)$$

TABLE 8 Cool Down

	3	2	1
Speed, r/min	1600	1000	1000
	17.1	7.5	
Load, kW (bhp)	(23)	(10)	Idle
Fuel rate	4.72	2.27	1.36
kg/h (lb/h)	(10.42)	(5.0)	(3.0)
Jet pressure ^A	158.6	158.6	158.6
kPa (psi), min.	(23)	(23)	(23)
Water out temp.	71.0		
°C (°F)	(160)		
Air inlet pressure	135.0	118.0	118.0
kPa (in. Hg Absolute)	(40.0)	(35.0)	(35.0)
Time, min	5	5	5

^A Oil pressure operating specifications apply only to 15W-40 oils. Attempt to maintain these limits for all oils. When oils other than 15W-40 oils fall outside these limits, explain these deviations from the limits in the comments section of the test report.

BSOC greater than 1.216 g/kW-h (0.002 lb/bhp-h) will invalidate the test. Plot each 12 h oil consumption point and include as the Oil Consumption Plot form of the test report.

11. Inspection

11.1 *Preparation*—Use a clean, soft, dry cloth (for example, cotton outing flannel) free from any solvents or polishes, and wipe the test piston free of oil film.

11.2 *Inspection*—Inspect the piston and liner, and photograph the piston at the end of the test. Make a complete written description of the inspection. Remove all rings from the piston before it is photographed. Determine and record cylinder liner and piston ring wear. Inspect the piston, rings, and liner in accordance with the report forms shown in ASTM Deposit Rating Manual 20, with the following exceptions:

11.2.1 Use a Sylvania 8 in. circular bulb, 20 W, cool white, Part # FC8T9-CW-RS^{24,11} in the rating lamp.

11.2.2 Conduct routine maintenance, such as bulb replacement, fixture cleaning, and booth repainting, on a regular basis.

11.2.3 Have a probe available for use in identifying questionable carbon-like deposits.

11.2.4 Use the recommended 20-segment template to obtain maximum precision. Each segment, which represents a 5 % area, should not be broken down into areas smaller than 1 %.

11.2.5 Evaluate only three levels of carbon in the piston grooves. They are defined as follows:

11.2.5.1 *Heavy Carbon*—Carbon that will take up the whole space between the back of the ring and the back of the groove and the lesser levels of carbon that exhibit polished areas due to an excessive amount of carbon on the back of the ring with relative ring movement.

11.2.5.2 *Medium Carbon*—Carbon that will take up to between approximately one-quarter to just less than the whole space between the back of the ring and the back of the groove.

11.2.5.3 *Light Carbon*—Carbon that will take up to approximately one-quarter of the space between the back of the ring and the back of the groove.

11.2.6 Evaluate only two levels of carbon on the ring lands. They are defined as follows:

11.2.6.1 *Heavy Carbon*—Carbon that shows signs of rubbing or polishing, or both.

11.2.6.2 *Light Carbon*—Any other carbon deposit.

11.2.7 For standardization of the interpretation of *clean*, keep a new piston in the rating booth for comparison. Replace this piston daily with another new piston, if possible.

11.3 *Rater Training*—Each lab shall send, on a calendar year basis, a minimum of one heavy duty diesel piston rater to either the Task Force meeting held every spring or expanded Heavy Duty Piston Rating Workshop held every fall. Each rater shall rate a minimum of six diesel pistons. If this schedule is not suitable to a particular rater or test lab, then alternative arrangements shall be made as soon as possible to have the rater calibrated.

11.4 *Referee Ratings*—To quickly detect and correct any shifts in rater severity, all operationally valid calibration tests shall be refereed. Obtain referee ratings only from another calibrated test lab. Wrap all pistons being shipped for referee ratings in paper, place in plastic with desiccant, and then seal before placing in any other shipping container.

12. Calibration of Test Method

12.1 *Requirements*—To maintain test consistency and severity levels, engine test stand calibrations are required at regular intervals.

12.2 *Reference Oils*—The reference oils used to calibrate 1M-PC test stands have been formulated or selected to represent specific chemical types and performance levels. They are available from the ASTM TMC. The TMC will assign reference oils for calibration tests. These oils are supplied under code numbers (blind reference oils).

12.3 *Test Numbering*:

12.3.1 Number each 1M-PC test to identify the test stand number and the test run number. Number all runs sequentially. Append repeat calibration runs with a letter (also sequential). Maintain the letter suffix sequencing for each test type calibration until the calibration has been accepted. Any test start, regardless of type, increments the run number. Test start is defined in 12.4.

12.3.2 An example of test numbering:

	1M-PC Test	Text X
1st Test	1 Ref. Fail	
2nd Test	2A Ref. Fail	
3rd Test	3B Ref. Fail	
4th Test		4 Ref. Fail
5th Test		5A Ref. Pass
6th Test	6C Ref. Pass	
7th Test	7 Candidate	
8th Test		8 Candidate

12.4 *Definition of Test*—A test (or test start) is defined, for purposes of this test method, as any engine *test time* accumulated in accordance with this test method.

12.5 *New Laboratories and New Test Stands*:

12.5.1 *New Test Stands*—A new stand is defined as a test engine and support hardware that has never been previously calibrated under this test method.

12.5.2 *New Laboratory*—A new laboratory shall have two calibration test passes on approved reference oils to be considered valid.

12.5.3 *Special Circumstances*—A laboratory not running a 1M-PC test for twelve months from the start of the last test is considered a new laboratory. Under special circumstances (that is, extended downtime due to industry-wide parts shortage or fuel outages) the TMC may extend the lapsed time requirement. Annotate non-reference tests conducted during an extended time allowance in the comments section of the Un-scheduled Downtime and Maintenance Summary form of the test report.

12.6 *Frequency of Calibration Tests*:

12.6.1 A calibration test on a reference oil assigned by the TMC is required after no more than 14 test starts or after six months from the start date of the last acceptable calibration test (whichever comes first). The 1M-PC calibration run is not

²⁴ Available from Newark Electrical Corp., 500 N. Pulaski Road, Chicago, IL 60624.

counted as one of the 14 test starts; however, *all* other test starts are counted. The TMC is permitted to move up or extend reference tests to enhance reference test program design and test severity monitoring. If a reference test calibration period is extended beyond the normal duration, note this fact in the comments section of the Unscheduled Downtime and Maintenance Summary form of the test report for all subsequent non-reference tests. Also attach written confirmation from the TMC to the report.

12.6.2 Start any non-reference test prior to the expiration of the calibration period.

12.7 *Guidelines for Adjustments to Calibration Periods*—Reference oil test frequency may be adjusted for the following reasons:

12.7.1 *Procedural Deviations*—On occasions when a laboratory becomes aware of a significant deviation from the test method, such as might arise during an in-house review or a TMC inspection, the laboratory and the TMC shall agree on an appropriate course of action to remedy the deviation. This action may include the shortening of existing reference oil calibration periods.

12.7.2 *Parts and Fuel Shortages*—Under special circumstances, such as industry-wide parts or fuel shortages, the surveillance panel may direct the TMC to extend the time intervals between reference oil tests. These extensions shall not exceed one regular calibration period.

12.7.3 *Reference Oil Test Data Flow*—To ensure continuous severity and precision monitoring, calibration tests are conducted periodically throughout the year. There may be occasions when laboratories conduct a large portion of calibration tests in a short period of time. This could result in an unacceptably large time frame when very few calibration tests are conducted. The TMC can shorten or extend calibration periods as needed to provide a consistent flow of reference oil test data. Adjustments to calibration periods are made such that laboratories incur no net loss (or gain) in calibration status.

12.7.4 *Special Use of the Reference Oil Calibration System*—The surveillance panel has the option to use the reference oil system to evaluate changes that have potential impact on test severity and precision. This option is only taken when a program of donated tests is not feasible. The surveillance panel and the TMC shall develop a detailed plan for the test program. This plan requires all reference oil tests in the program to be completed as close to the same time as possible, so that no laboratory/stand calibration is left in an excessively long pending status. In order to maintain the integrity of the reference oil monitoring system, each reference oil test is conducted so as to be interpretable for stand calibration. To facilitate the required test scheduling, the surveillance panel may direct the TMC to lengthen and shorten reference oil calibration periods within laboratories such that the laboratories incur no net loss (or gain) in calibration status.

12.8 *Donated Reference Oil Test Programs*—The Surveillance Panel is charged with maintaining effective reference oil test severity and precision monitoring. During times of new parts introductions, new or re-blended reference oil additions, and procedural revisions, it may be necessary to evaluate the possible effects on severity and precision levels. The surveil-

lance panel may choose to conduct a program of donated reference oil tests in those laboratories participating in the monitoring system, in order to quantify the effect of a particular change on severity and precision. Typically, the surveillance panel requests its panel members to volunteer enough reference oil test results to create a robust data set. Broad laboratory participation is needed to provide a representative sampling of the industry. To ensure the quality of the data obtained, donated tests are conducted on calibrated test stands. The surveillance panel shall arrange an appropriate number of donated tests and ensure completion of the test program in a timely manner.

12.9 *Procedural Deviations*—On occasions when a laboratory becomes aware of a significant deviation from the test method, such as might arise during an in-house review or a TMC inspection, the laboratory and the TMC shall agree on an appropriate course of action to remedy the deviation. This action may include the shortening of existing reference oil calibration periods.

12.10 *Specified Test Parameters*—The specified test parameters for determination of test acceptance are:

12.10.1 Top groove fill, percent area.

12.10.2 Weighted total deposits, demerits.

12.11 *Acceptance of Calibration Tests*—Refer to the TMC's Lubricant Test Monitoring System (LTMS) for calibration test targets and acceptance criteria.

12.12 *Failing Reference Oil Calibration Tests:*

12.12.1 Failure of a calibration test to meet test acceptance bands can indicate a testing stand problem, testing laboratory problem, or industry-wide problem, or it can be a false alarm. When this occurs, the laboratory, in conjunction with the TMC, must attempt to determine the problem source.

12.12.2 In the determination of the problem, TMC will decide, with input as needed from industry expertise (testing laboratories, test developer, ASTM Technical Guidance Committee, Surveillance Panel, and so forth), if the reason for any unacceptable blind reference oil test is isolated to one particular stand or related to other stands. If it is decided that the problem is isolated to an individual stand, calibrated testing on other stands can continue throughout the laboratory. Alternatively, if it is decided that more than one stand may be involved, the involved stands will not be considered calibrated until the problem is identified and corrected and an acceptable reference oil test is completed in one of the involved stands.

12.13 *Non-Standard Tests*—If non-standard tests are conducted on the referenced test stand, the stand may, at the discretion of the TMC, be required to be recalibrated prior to running standard tests.

12.14 *Severity Adjustments and Control Charting:*

12.14.1 *Severity Adjustments*—This test method incorporates the use of a surveillance panel accepted method of calculating a severity adjustment (SA) for non-reference test results. A control chart technique, described in 12.14.2, has been selected for the purpose of identifying when a bias becomes significant. When a significant bias is identified, an SA is applied to non-reference test results. The SA remains in

effect until subsequent calibration test results indicate that the bias is no longer significant. SAs are calculated and applied on a laboratory basis.

12.14.2 *Control Chart Technique for SAs*—Apply an exponentially weighted moving average (EWMA) technique to standardized calibration test results. Standardize values using Δ/s (result - target)/standard deviation). The targets and standard deviations are published by the TMC. Include all operationally valid calibration tests in a laboratory control chart. Chart tests in order of completion. Record completion of tests by end of test (EOT) date and time. Report EOT as hour and minute in accordance with the 24 h clock (1 a.m. = 1:00, 1 p.m. = 13:00). Reporting test completion time enables the TMC to properly order tests that are completed on the same day for industry plotting purposes. Report calibration tests to the TMC in order of test completion. A minimum of two tests is required to initialize a control chart. Calculate EWMA values, using the following equation:

$$Z_i = \lambda Y_i + (1 - \lambda)Z_{i-1} \quad (3)$$

where:

- $Z_0 = 0$,
- $Y_i =$ standardized test result,
- $Z_i =$ EWMA of the standardized test result at test order i , and
- $\lambda =$ the appropriate λ from the LTMS document.

If the absolute value of EWMA, rounded to three places after the decimal, exceeds the alarm limit established in the LTMS document, then apply an SA to subsequent non-reference results.

12.14.3 *Calculation of SA*—Compute and apply EWMA and SA values as shown in the following example. Please note that test targets are presented for example only.

12.14.3.1 *Severity Adjustment Calculation Example:*

Applicable Test Targets: Mean = 40.8; Standard Deviation = 15.9; TGF = 55 $Z_1 = 0.897$
 Standard Test Result: $Y_2 = (TGF - \text{Mean})/STD = 0.893$
 Alarm Limit: 0.653

$$\text{EWMA: } Z_2 = 0.2Y_2 + 0.8Z_1 = 0.896 \quad (4)$$

Since $0.896 > 0.653$, apply an SA: $SA = -1 * \text{EWMA} * \text{STD}$ (in the above example, $SA = -14$). For TGF, the SA is rounded to a whole percent; for WTD, it is rounded to one decimal place. Enter this number in the appropriate Lab Severity Adjustment box and add it to the Unadjusted Lab Rating on the Test Report Summary form of the test report. An SA will remain in effect until the next calibration test. At that time, calculate a new EWMA and SA.

12.15 *Test Reporting:*

12.15.1 *Report Forms*—For reference oil tests, the standardized report forms and data dictionary for reporting test results and for summarizing the operational data are required. All report forms making up the 1M-PC final report are available at the TMC website (<http://www.astmtmc.cmu.edu>). For calibration tests, attach the control chart summary page sent to the lab from the TMC to the test report. An example of this and other forms are shown in Fig. X2.1 of Appendix X2 and Fig. X3.1 of Appendix X3.

12.15.2 *Deviation Percent and Offset Percent Calculation*—Offset percent measures how close any given test parameter is

run to the target mean. Deviation percent indicates excursions made by any given parameter outside the minimum or maximum limit. Calculate them as follows:

12.15.2.1 Round recorded values, if necessary, in accordance with the specifications listed on the U.S. Customary System (USCS) and SI specifications given in Table 3.

12.15.2.2 Use the test specifications and tolerances listed in Table 3 for the percent calculations.

12.15.2.3 Calculate the percent out and percent off, using the same units as the recorded data. For example, if the test is operated in USCS units, calculate the percentages using USCS units. Do not convert the units before figuring the percentages.

12.15.2.4 The logging frequency used for calculating the percentages will be at the discretion of the laboratory, but shall be at least hourly.

12.15.2.5 Include an explanation for any data used in the calculation of the percentages that are edited. List the data before they are edited, the new value, and the explanation for the change in the comments section of the Unscheduled Downtime and Maintenance Summary form of the test report.

12.15.2.6 Record these values on the Operational Summary–Offset And Deviation form of the test report.

12.15.2.7 Carry each percent out calculation to three significant digits (see Table 9).

12.15.2.8 Round the calculated average used in the percent off calculation to the measurement resolution shown in Table 2. See example in Table 9.

12.15.2.9 Round the percent out summation and percent off results to the minimum measurement resolution listed in Table 2 (see example in Table 9).

NOTE 3—Use ASTM rounding rules when carrying out 12.15.2.7 through 12.15.2.9.

TABLE 9 Example^A of Percent Out and Percent Off Calculations

NOTE 1—Percent out Summation = 8.33 (Round to 0.01).
 Average of the rounded values = 128.6 (round to 0.1).
 Percent offset = 15.5 (round to 0.1).

Test Hours	Raw Value g/kg	Rounded Value g/kg	% Out for Each Value Rounded to 0.001
1	18.65	18.7	
2	18.65	18.7	
3	18.55	18.6	
4	17.96	18.0	
5	18.28	18.3	
6	17.96	18.0	
7	18.00	18.0	
8	17.73	17.7	
9	17.59	17.6	
10	16.90	16.9	
11	15.99	16.0	0.053
12	15.21	15.2	0.437
13	18.28	18.3	
14	18.95	19.0	
15	19.27	19.3	
16	19.64	19.6	0.067
17	19.95	20.0	0.221
18	19.67	19.7	0.081
19	19.64	19.6	0.067
20	19.95	20.0	0.221
21	18.06	18.1	

^A This example is for 21 test hours, using humidity measured in grains/lb.

12.15.2.10 An example of the calculation for percent out for test hour eleven, using the formula shown in 12.15.2.11, is as follows:

$$\% \text{ Out} = \frac{\frac{112 - 113}{12} \times \frac{60}{60} \times 100}{120} = 0.069 \quad (5)$$

12.15.2.11 Use the following formula to calculate the percent out:

$$\% \text{ Out} = \frac{\frac{|A - B|}{C} \times \frac{D}{60} \times 100}{120} \quad (6)$$

where:

- A = recorded test measurement of parameter that is beyond test limits prior to any corrective action,
- B = upper test spec if the measured parameter is out on the high side, and the lower test spec if it is out on the low side,
- C = specification tolerance of the measured parameter,
- D = length of deviation in minutes (it cannot be less than the logging frequency),
- 60 = conversion factor for min/h, and
- 100 = conversion factor for percentage units.

Calculate the percent out for each measured parameter, based on its logging frequency. Sum the individual percent out's to arrive at the final percent out for judging test validity (see Table 10).

12.15.2.12 Use the following formula to calculate the percent off:

$$\% \text{ Off} = \frac{|\bar{X} - \text{SPEC}| \times 100}{\text{SPEC RANGE}} \quad (7)$$

where:

- \bar{X} = average of all readings of the parameter for the entire test duration, and
- SPEC RANGE = the upper spec minus the lower spec, or two times the spec tolerance.

TABLE 10 Allowable Limits for Percent Out and Percent Off

Controlled Parameter ^A	Allowable % Out	Allowable % Off
Speed	5	20
Fuel flow	10	25
Humidity	10	25
Coolant flow	5	25
Temperatures		
Coolant out	5	20
Oil to bearing	5	20
Intake air	5	20
Pressures		
Oil jet ^B	5	25
Intake air	10	25
Exhaust	10	25
Fuel at filter housing	5	20
Crankcase vacuum	10	20

^A The parameters in this table shall be used to judge test validity based on operational control. Any parameter for a given test with a percent out or percent off that is *greater than* the specifications listed shall be considered to be operated in an invalid manner.

^B Oil pressure operating specifications apply only to 15W-40 oils. Attempt to maintain these limits for all oils. When oils other than 15W-40 oils fall outside these limits, explain these deviations from the limits in the comments section of the test report.

12.15.3 *Electronic Data Communication and Data Dictionary*—Use the data dictionary and report forms available at the TMC website (<http://www.astmtmc.cmu.edu>) for any electronic transmission of data to the TMC. The data dictionary lists all variable names given to all fields as well as the important information about those fields.

12.16 *Reporting Reference Results*—Transmit the calibration test results by fax or electronic data transmission to the ASTM TMC immediately after completion of test analysis.

12.16.1 Though referee ratings are required for all operationally valid tests reported to TMC, statistical validity of the test is computed using the ratings produced by the test lab; referee ratings are used only to reveal rating errors. Report referee results to the TMC on the Referee Rating form of the test report within ten working days of the test completion.

12.16.2 The TMC will review all calibration test results to determine test acceptability. If the test is judged acceptable, the reference oil code along with the industry average for the reference oil, will be disclosed by the TMC. In the event the reference oil test is not acceptable, an explanation of the problem relating to the failure is to be provided by the test laboratory. If the problem is not obvious, recheck all test-related equipment. If no explanation of the problem is presented, it will be assumed that the problem is laboratory-related and another reference oil will be assigned.

12.17 *Analysis of Reference Oils*—Do not submit reference oils to physical or chemical analyses for identification purposes. Identifying the oils by analyses could undermine the confidentiality required to operate an effective blind reference oil system. Therefore, reference oils are supplied with the explicit understanding that they will not be subjected to analyses other than those specified within this test method unless specifically authorized by the ASTM TMC. In such cases in which analyses are authorized, supply written confirmation of the circumstances involved, the data obtained, and the name of the person authorizing the analysis to the ASTM TMC.

13. Precision and Bias

13.1 Test precision is established on the basis of reference oil test results (for operationally valid tests) monitored by the ASTM Test Monitoring Center. The data are reviewed semi-annually by the Single-Cylinder Diesel Surveillance Panel. Contact the ASTM TMC for current industry data.

13.1.1 Table 11 summarizes reference oil intermediate pre-

TABLE 11 1M-PC Reference Oil Precision Statistics

NOTE 1—These statistics are based on Test Monitoring Center reference oils between April 8, 1995 and Jan. 24, 2005.

Test Parameter	S _{i.p.}	i.p.	S _R	R
TGF—top groove fill, %	17.3	48.4	17.8	49.8
WTD—weighted total piston deposits, demerits	45.7	128.0	47.0	131.6

Legend:

S_{i.p.} = intermediate precision standard deviation

i.p. = intermediate precision

S_R = reproducibility standard deviation

R = reproducibility

cision and reproducibility of the test. The tabulated values are current as of Feb. 1, 2005. The Surveillance Panel updates these values as necessary.

13.1.2 *Intermediate Precision Conditions*—Conditions where test results are obtained with the same test method using the same test oil, with changing conditions such as operators, measuring equipment, test stands, test engines, and time.

NOTE 4—Intermediate precision is the appropriate term for this test method rather than repeatability which defines more rigorous within-laboratory conditions.

13.1.2.1 *Intermediate Precision Limit (i.p.)*—The difference between two results obtained under intermediate precision conditions that would, in the long run, in the normal and correct conduct of the test method, exceed the values shown in **Table 11** in only one case in twenty. When only a single test result is available, the Intermediate Precision Limit can be used to calculate a range (test result \pm Intermediate Precision Limit) outside of which a second test result would be expected to fall about one time in twenty.

13.1.3 *Reproducibility Conditions*—Conditions where test results are obtained with the same test method using the same test oil in different laboratories with different operators using different equipment.

13.1.3.1 *Reproducibility Limit (R)*—The difference between two results obtained under reproducibility conditions that would, in the normal and correct conduct of the test method, exceed the values shown in **Table 11** in only one case in twenty. When only a single test result is available, the Reproducibility Limit can be used to calculate a range (test result \pm Reproducibility Limit) outside of which a second test result would be expected to fall about one time in twenty.

13.2 *Bias*—Bias is determined by applying an acceptable statistical technique to reference oil test results, and when a significant bias is determined, a severity adjustment is permitted for non-reference oil test results (see TMC Memorandum 94-200, Lubricant Test Monitoring System document for details).

14. Keywords

14.1 1M-PC; diesel engines; heavy-duty performance; ring belt deposits; single cylinder test

ANNEXES

(Mandatory Information)

A1. SCHEMATICS

A1.1 See **Table A1.1** for the bill of material for surge chamber and air heater assembly.

A1.2 See **Figs. A1.1-A1.35** for schematic drawings and information relating to the engine used in this test method.

TABLE A1.1 Bill of Material - Surge Chamber and Air Heater Assembly

NOTE 1—All dimensions are in inches unless otherwise specified.

Item No.	Name	Caterpillar Tractor Co. Part No.	Description	No. Req'd	Ref Fig.
1-1	Surge chamber & heater Assembly			1	
1-2	Bolt	L1648	3/8- 24 thd 2.50 long ^A	1	
1-4	Thermostatic switch			2	
1-5	Lockwasher	3B4506	Std. for 0.375 dia bolt	20	
1-6	Bolt	2A4996	3/8- 24 thd 1.375 long ^B	20	
1-7	Pressure relief valve			1	
1-8	Gasket		0.0312 thick ^C	1	
1-9	Mounting plate		20×12×0.0625 thick SAE steel	1	
1-10	Spacer	8B7430	0.750 OD 0.359 ID 0.531 thick SAE steel	4	Fig. A1.23
1-11	Bolt	L1590	1/4- 28 thd 1.125 long	4	
1-12	Lockwasher	3B4504	Std. for 0.250 dia bolt	4	
1-13	Nut	1B4201	1/4- 28 thd	4	
1-14	Electrical junction box		12 × 18 × 4 std pull box w/hinged cover ^D	1	
1-15	Strip heater			24	
1-16	Gasket		0.0312 thick ^C	1	
2-1	Assembly			1	
2-2	Top ring			1	
2-3	Bottom plate			1	Fig. A1.24
2-4	Strap-surge chamber			2	
2-5	Hook			2	
2-6	Pad			1	
3-1	Assembly			1	
3-2	Top cover			1	
3-3	Inner bracket			1	Fig. A1.25
3-4	Outer bracket			1	
4-1	Terminal assembly			5	
4-2	Nut		7/16 - 14 thd SAE 73 brass	29	
4-3	Washer		Std. for 0.437 dia. bolt	10	
4-4	Insulator		1.250 OD 0.453 ID .187 thick Synthane	5	Fig. A1.26
4-5	Stud		7/16 - 14 thd 3 long brass	5	
4-6	Collar			5	
4-7	Insulator assembly			48	
4-8	Washer		.750 OD .265 ID 0.125 thick Mica	48	
4-9	Insulator		.500 OD .265 ID 0.0625 thick Synthane	48	
4-10	Insulator		1.687×1×0.0625 w/0.265 hold Mica	48	
4-11	Bolt		1/4-20 thd 1 long	48	
4-12	Washer		Std. for 0.250 dia bolt	48	
4-13	Nut		Std. for 1/4 20 thd	48	
4-14	Electric cable cover			1	
4-15	Terminal connector			As Req'd	
4-16	Lower bracket assembly			1	

^A 40 °F per turn - normally closed - contacts open with increase of temperature. Turning screw counter-clockwise causes contacts to open at a higher temperature.

^B Set to "pop off" at 137.9 kPa ± 3.4 kPa (20 psi ± 0.5 psi).

^C Make gasket to fit top ring (2-2) and pad (2-6).

^D Terminal on element goes to inside of barrel on inner rings and to outside of barrel on outer rings.

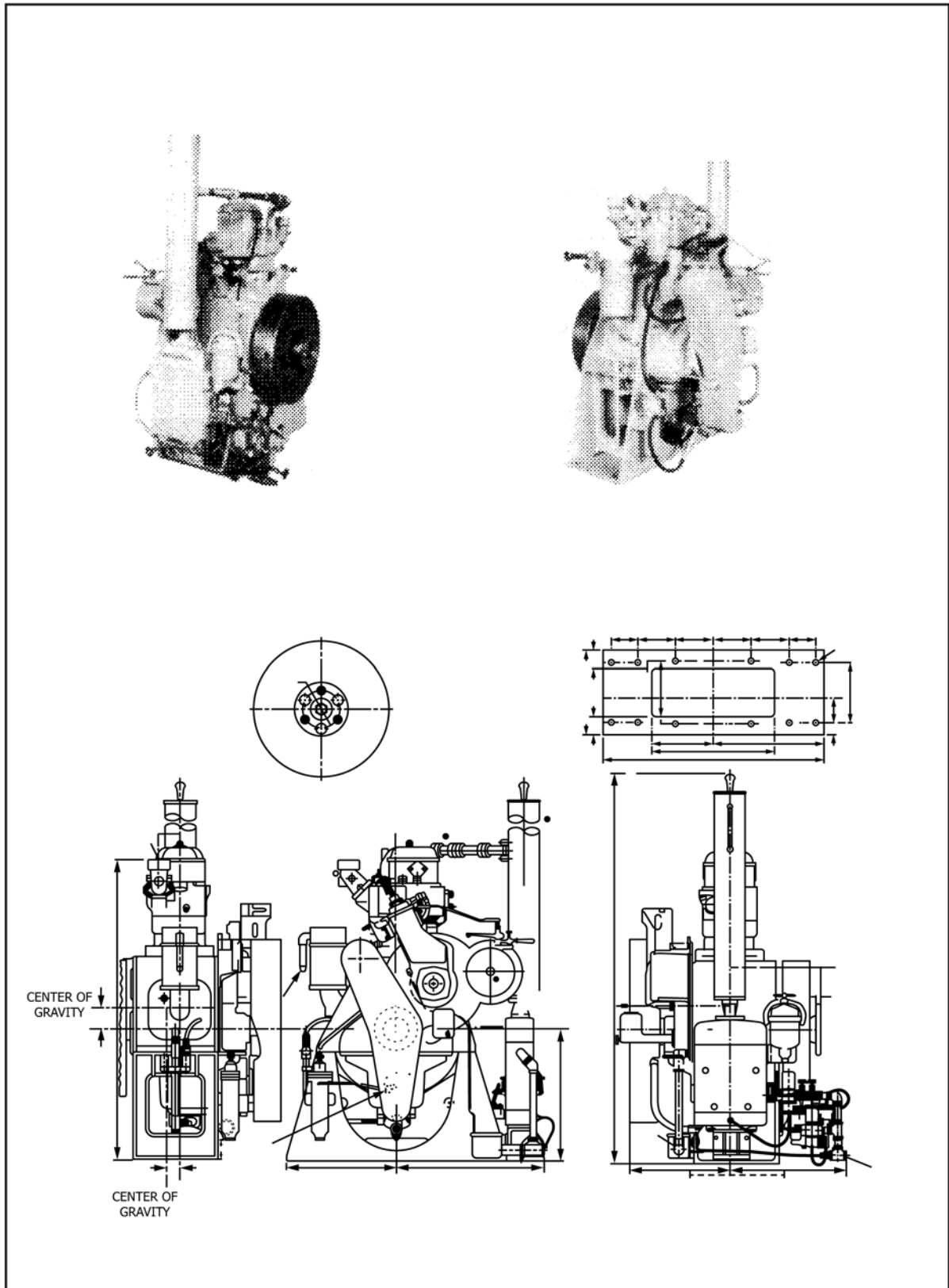

FIG. A1.1 1Y73 Engine Arrangement

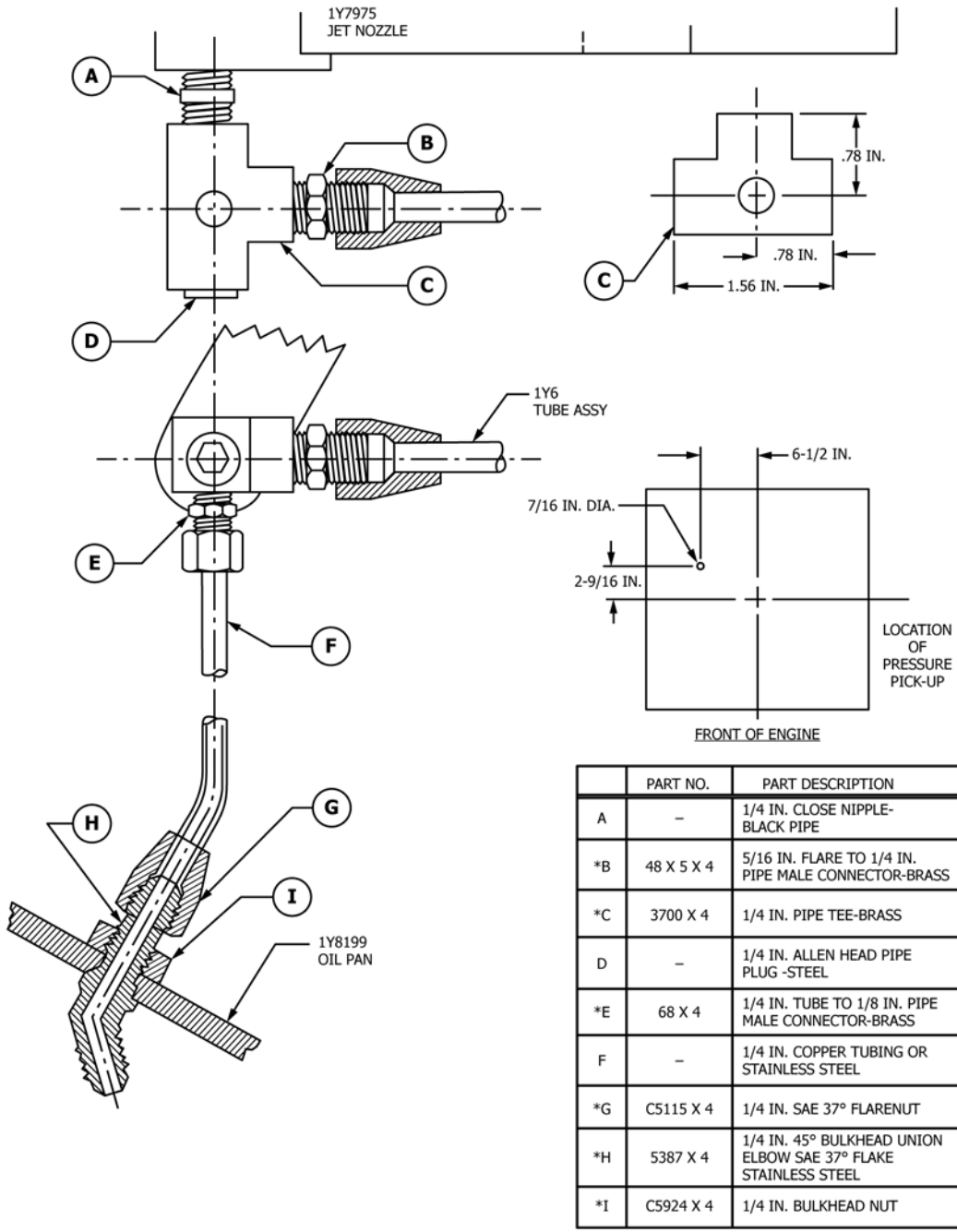
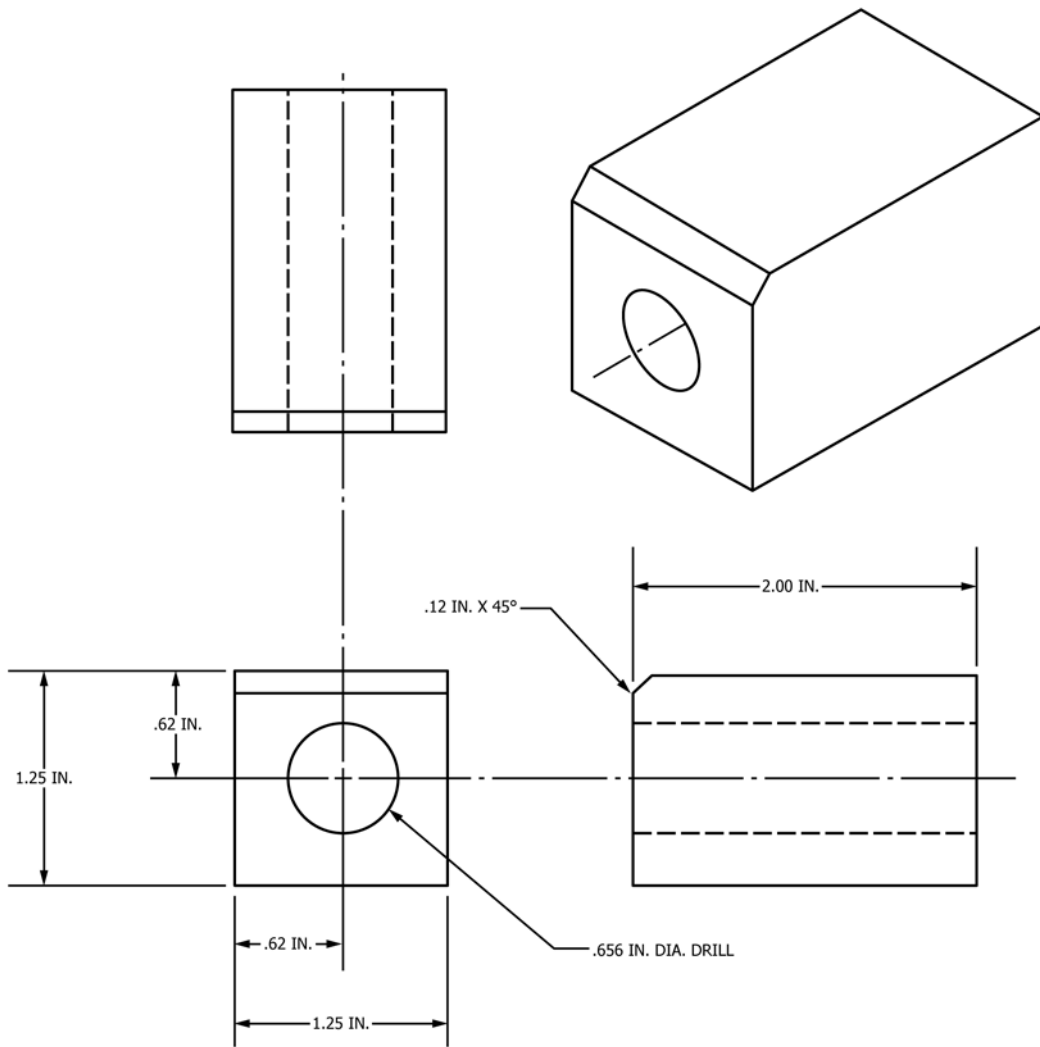

FIG. A1.2 Suggested Piston Cooling Nozzle Pressure Pick-up



- NOTE 1—1—Material—mild steel.
 2—Two required per engine.
 3—Replace mounting bolts 8B5144 with two 6F7024 bolts.

FIG. A1.3 Bayonet Oil Gauge Lowering Spacer

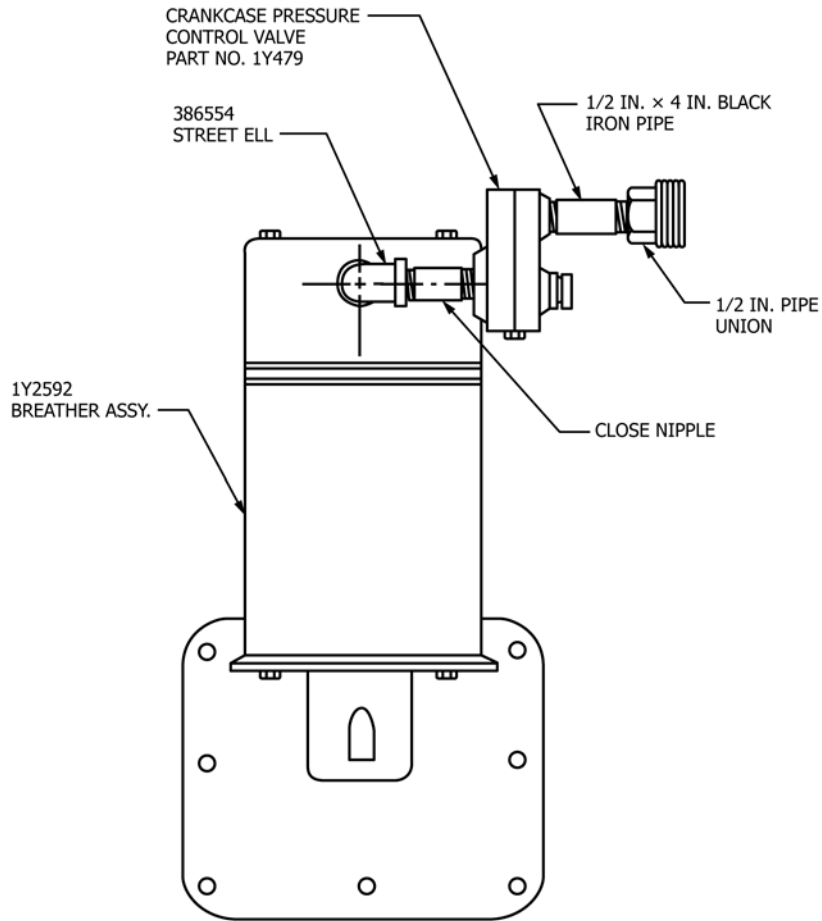
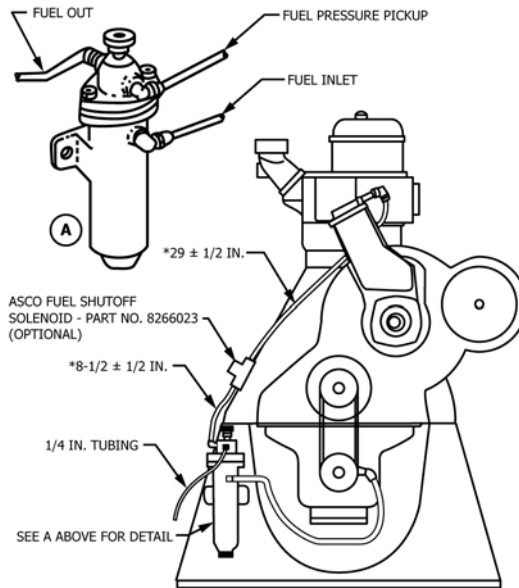

FIG. A1.4 Crankcase Pressure Control Valve Installation



NOTE 1— $\frac{3}{8}$ in. I.D. Aeroquip hose type 2556-6.
 FIG. A1.5 Standardized Engine Fuel System

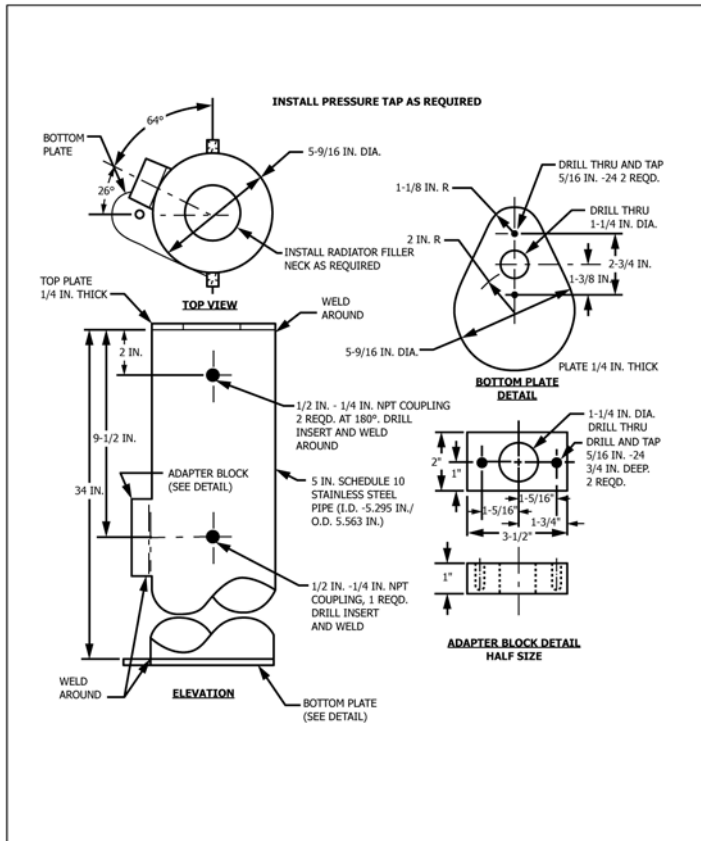
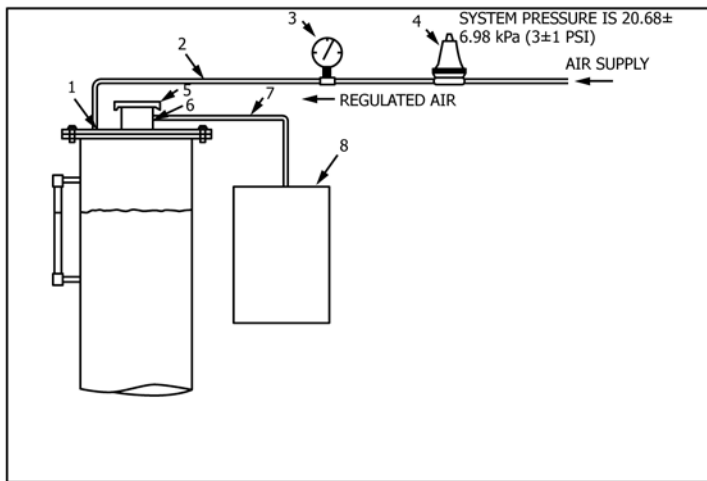

FIG. A1.6 Pressurized 5-in. Cooling Tower



NOTE 1—Legend:

1. 1/4 in. NPT-TO-No. 4 AN (male connector)
2. No. 4 Hose
3. Pressure gauge 0–15 PSIG
4. Pressure regulator (self bleeding)
5. Radiator cap 15–16 PSIG
6. Radiator filler neck
7. Overflow tube (optional)
8. Overflow tank (optional)

NOTE 2—If the system builds to greater than regulator setting, then condensate will back-flow through regulator.

FIG. A1.7 Cooling System Modification

ALTERNATIVELY, THE SIGHTGLASS MAY BE PLACED BEFORE THE BARCO SO LONG AS THE MINIMUM PIPE LENGTHS IN AND OUT ARE MET.

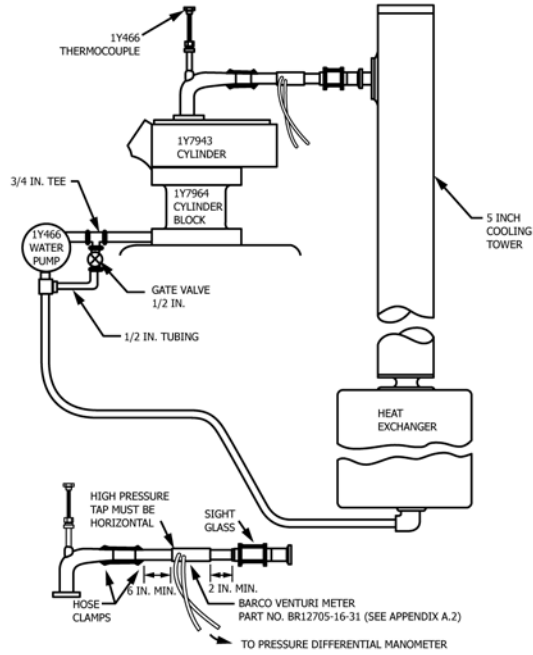
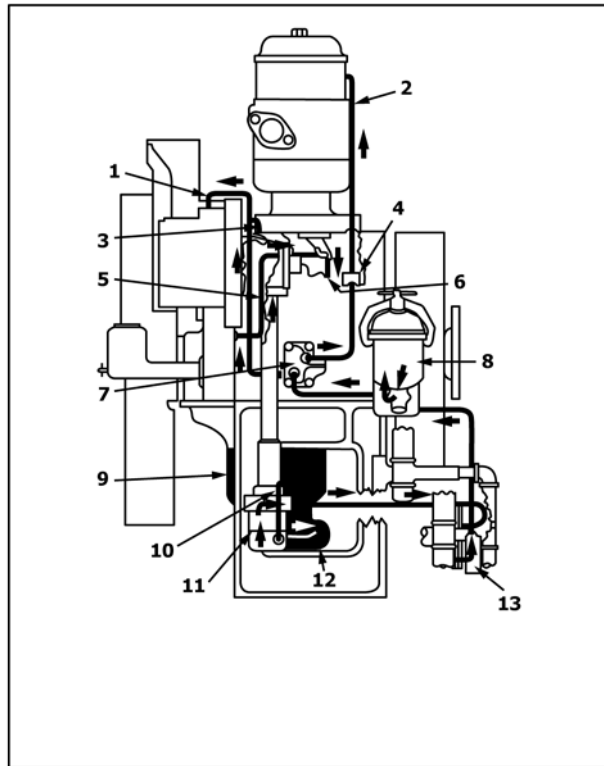

FIG. A1.8 Recommended Cooling System



NOTE 1—Legend:

1. Line to fuel cam.
2. Line to rockerarm.
3. Line to accessory shaft.
4. Rear cam bearing
5. Line to piston cooling jet
6. Line, jet pressure pickup.
7. Manifold
8. Oil filter.
9. Oil pan.
10. Bypass line.
11. Oil pump.
12. Oil pump supply line.
13. Oil cooler assembly.

FIG. A1.9 Oil Flow Schematic

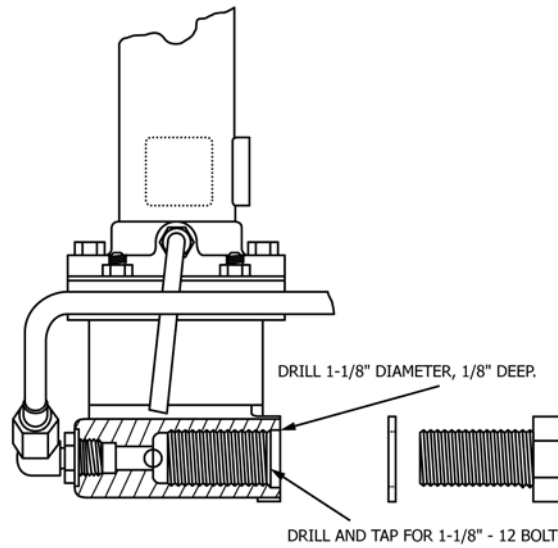

INSTALL: 1 - 2H3751 BOLT (1-1/8-12 X 2-1/2")
 1 - 5B3265 GASKET

NOTE 1—If desired, bolt thread may be sealed with 7M7456 bearing mount.

FIG. A1.10 Oil Pump Relief Valve Plug

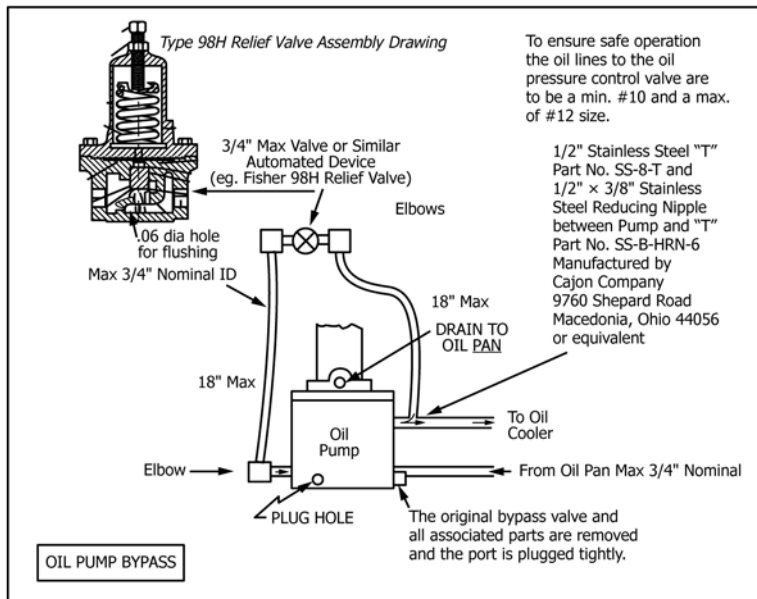
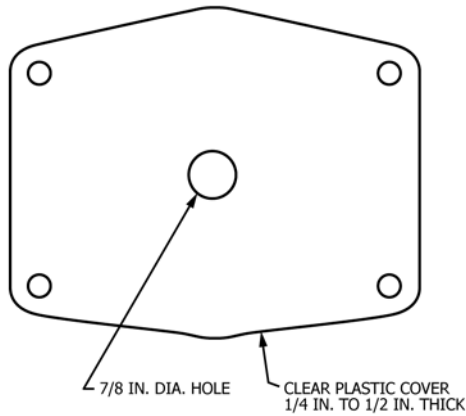
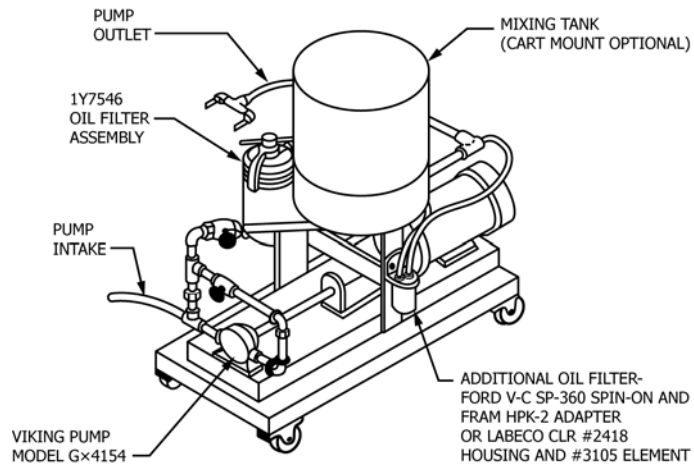

FIG. A1.11 Remote Mount Oil Pump Relief Valve



NOTE 1—Use 1Y3698 gasket as pattern for bolt hole locations.

FIG. A1.12 Clear Plastic Cover



NOTE 1—Portable cart, optional.

FIG. A1.13 Typical Flushing Pump Arrangement

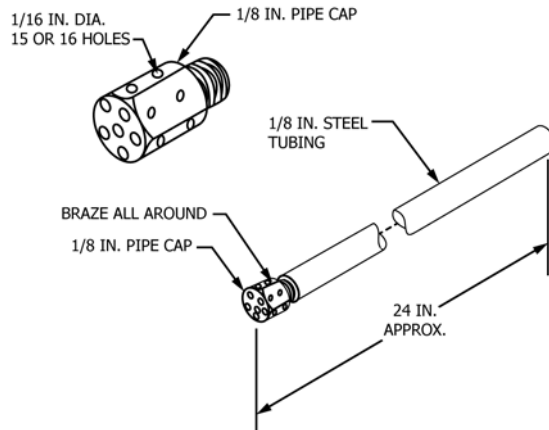

FIG. A1.14 Crankcase/Governor Housing Sprayer

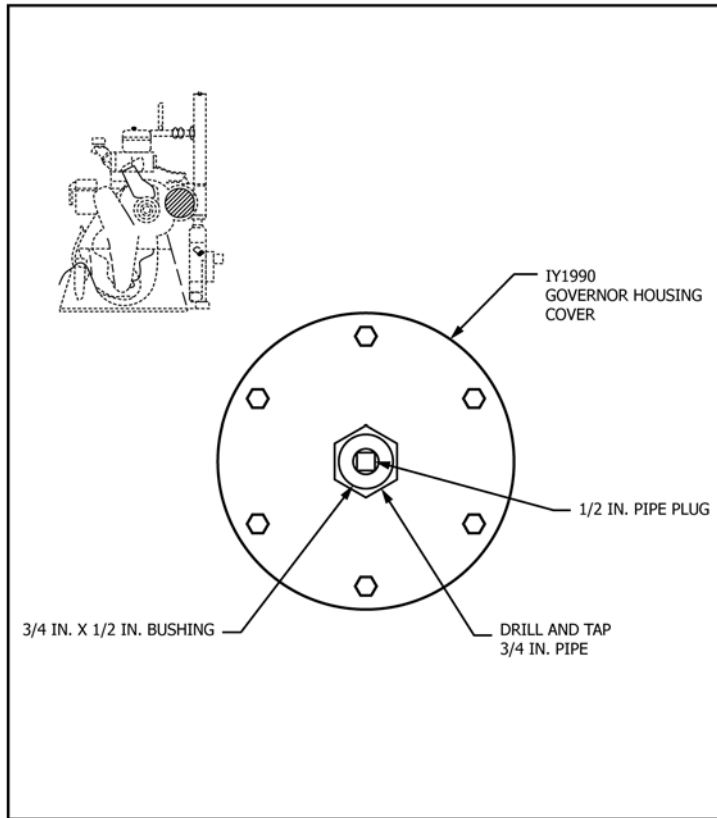

FIG. A1.15 Governor Housing Cover Modification

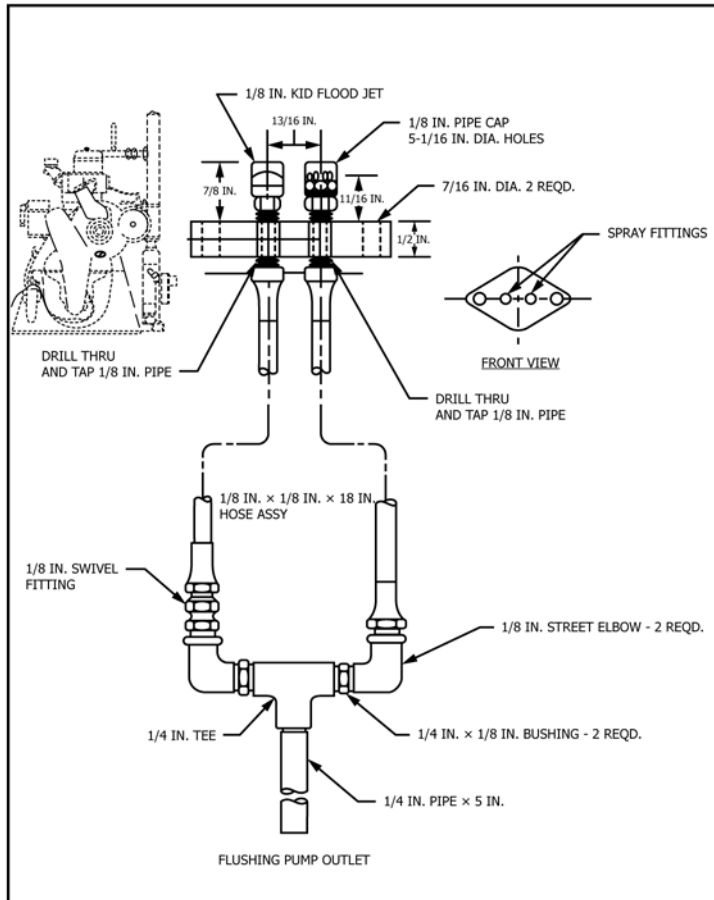

FIG. A1.16 Front Cover Sprayer

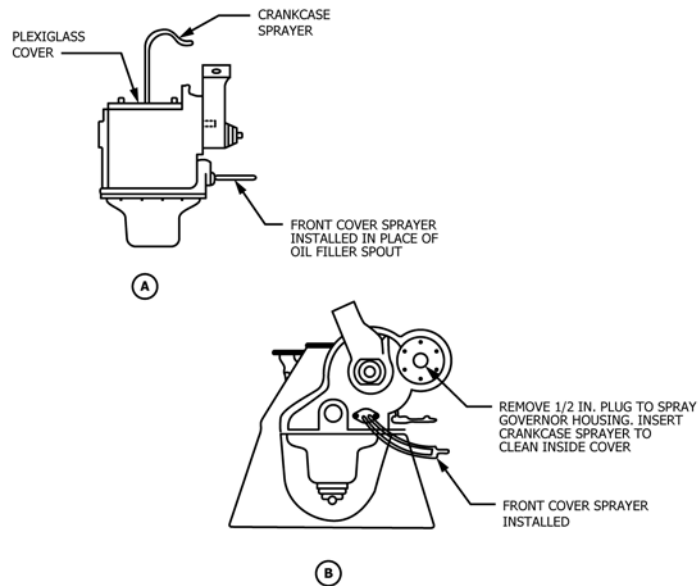

FIG. A1.17 Flushing Components Location

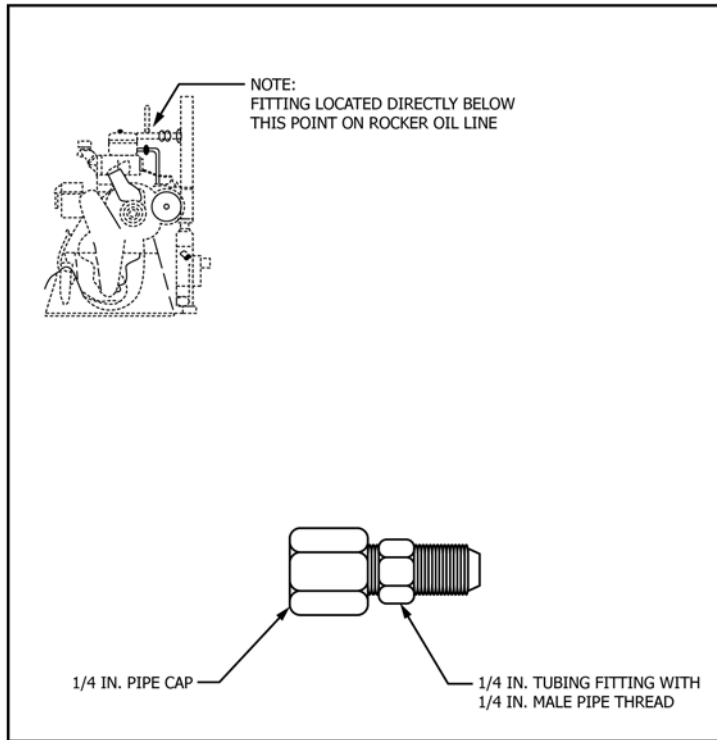

FIG. A1.18 Rocker Oil Line Blocking-off Fitting

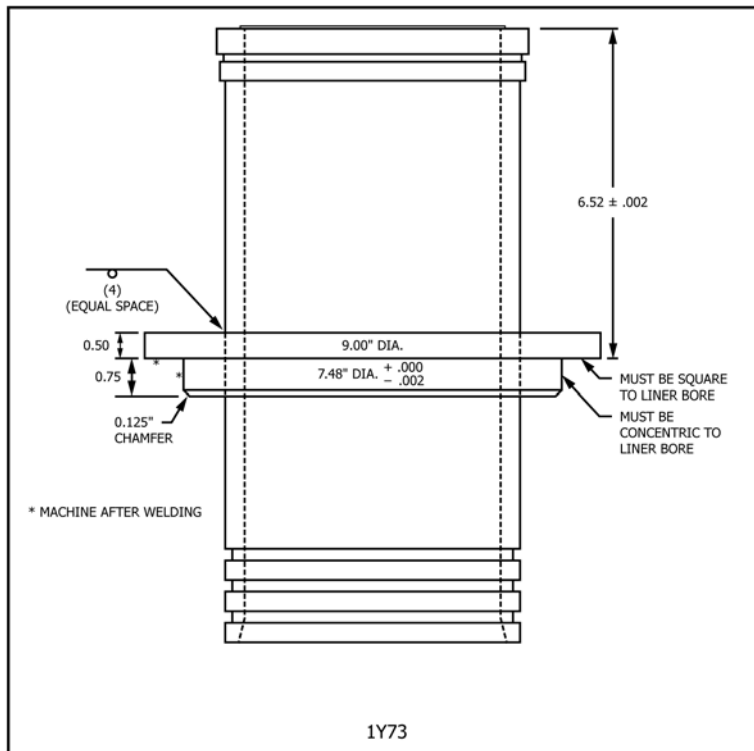
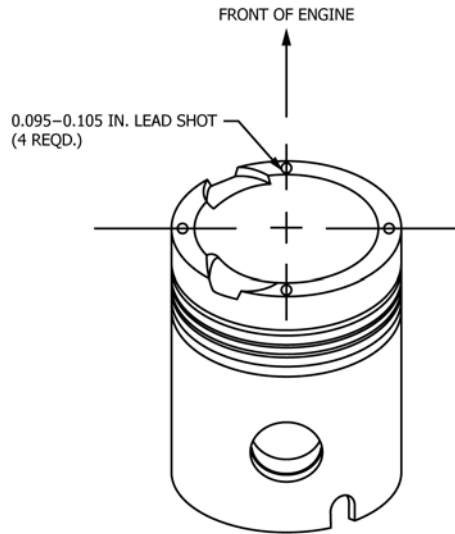

FIG. A1.19 Jet Alignment Fixture



NOTE 1—Lead shot are oriented with axis of piston as viewed from the top.
FIG. A1.20 Placement Location of Lead Shot

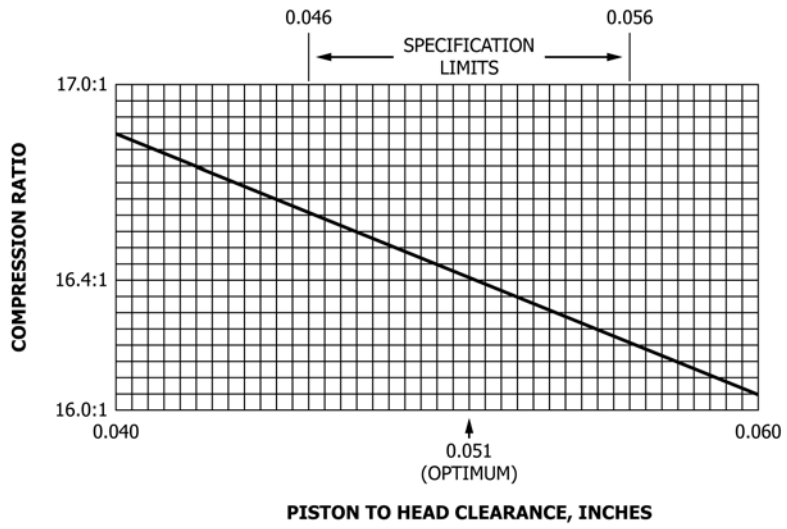

FIG. A1.21 Compression Ratio Versus Piston to Head Clearance

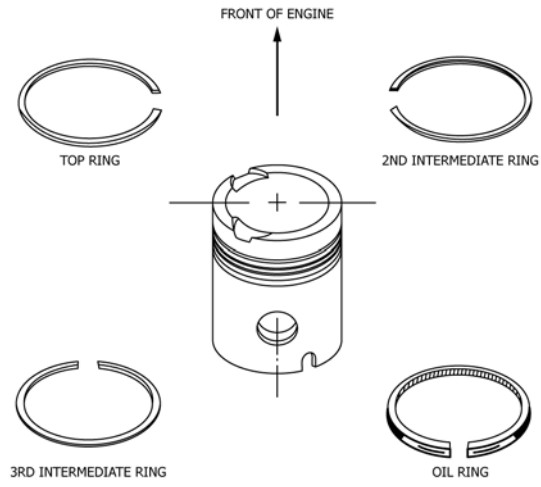

FIG. A1.22 Piston Ring Gap Orientation

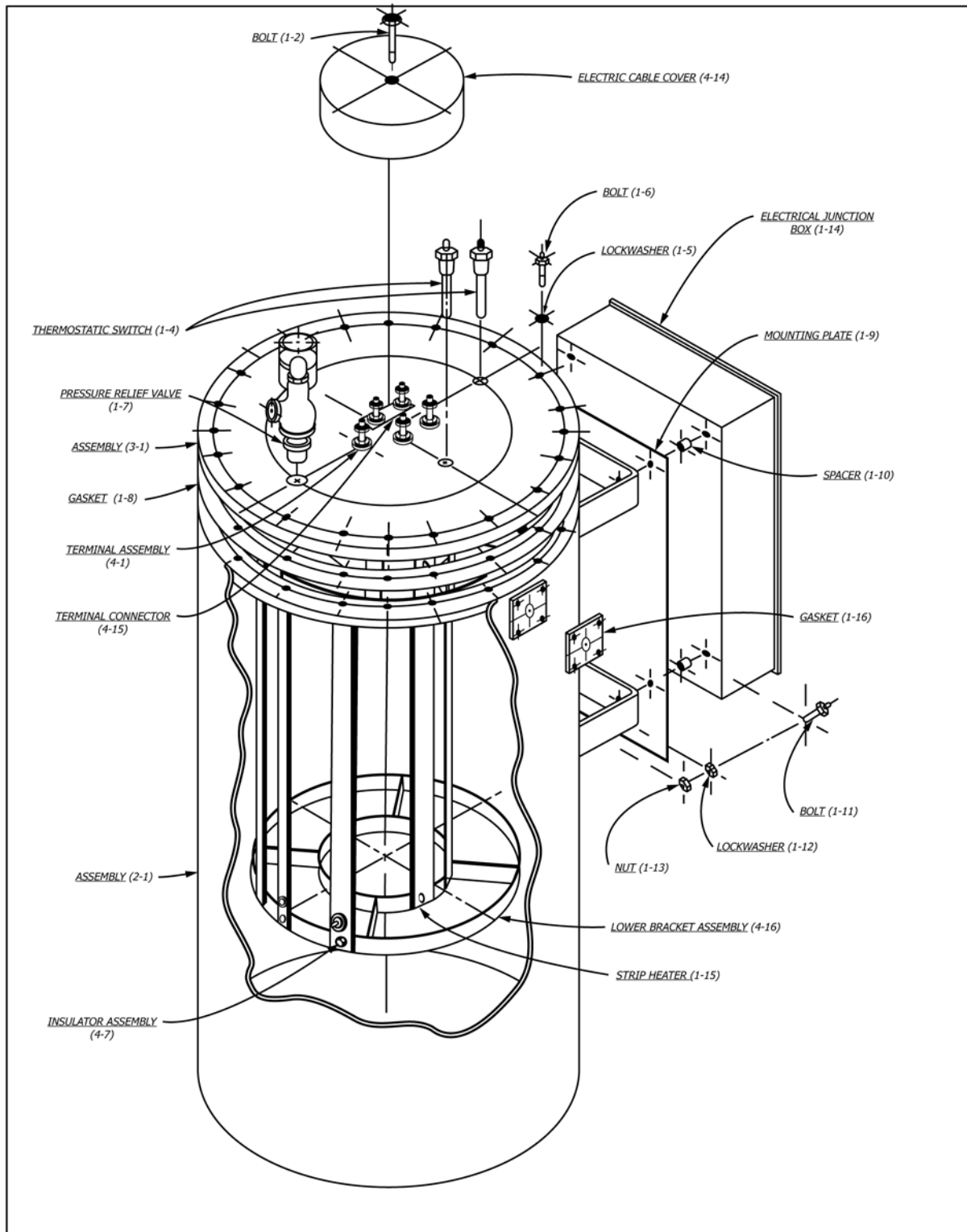

FIG. A1.23 Surge Chamber and Air Heater Assembly (1-1)

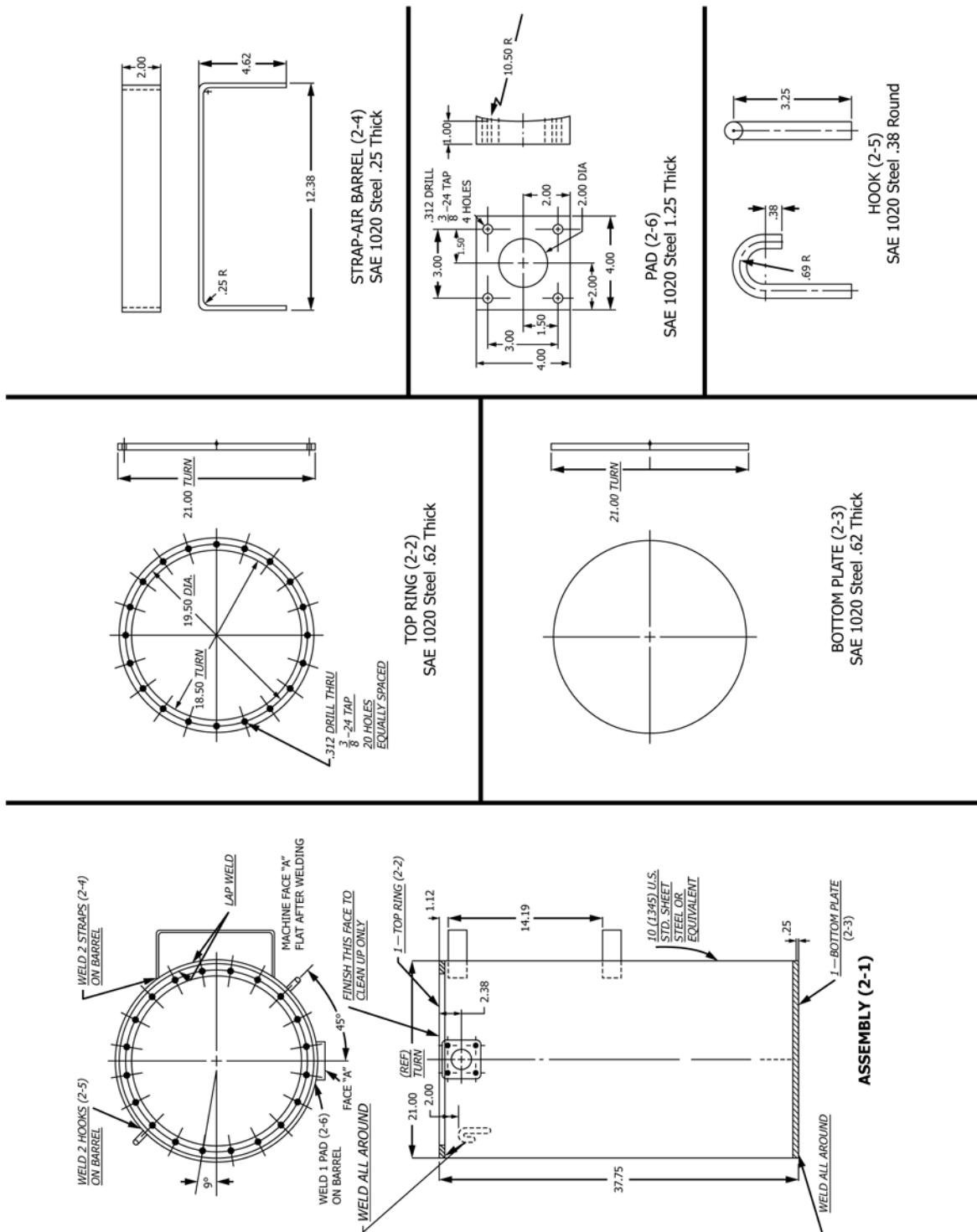

FIG. A1.24 Air Barrel Construction

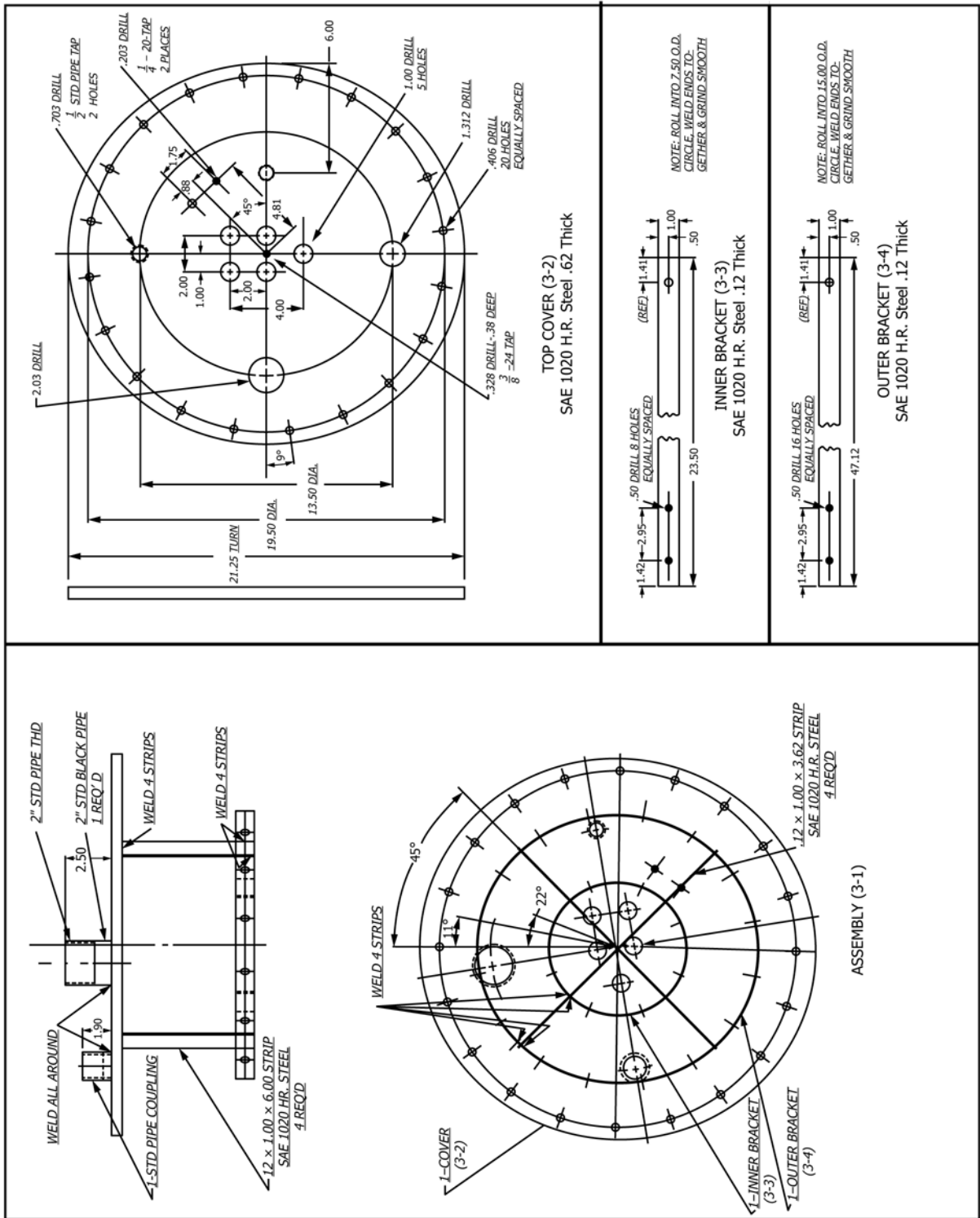

FIG. A1.24 Air Barrel Construction (continued)

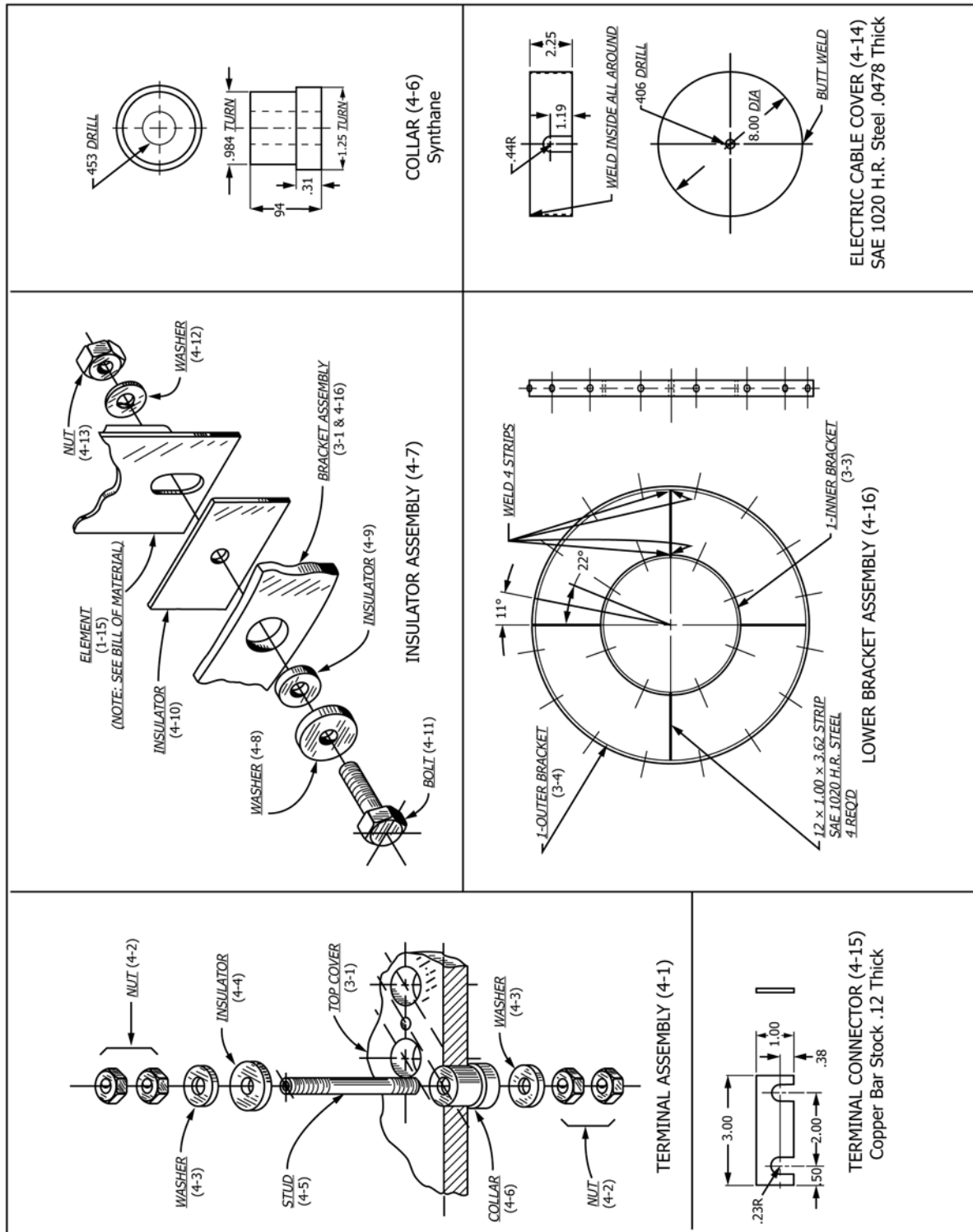

FIG. A1.24 Air Barrel Construction (continued)

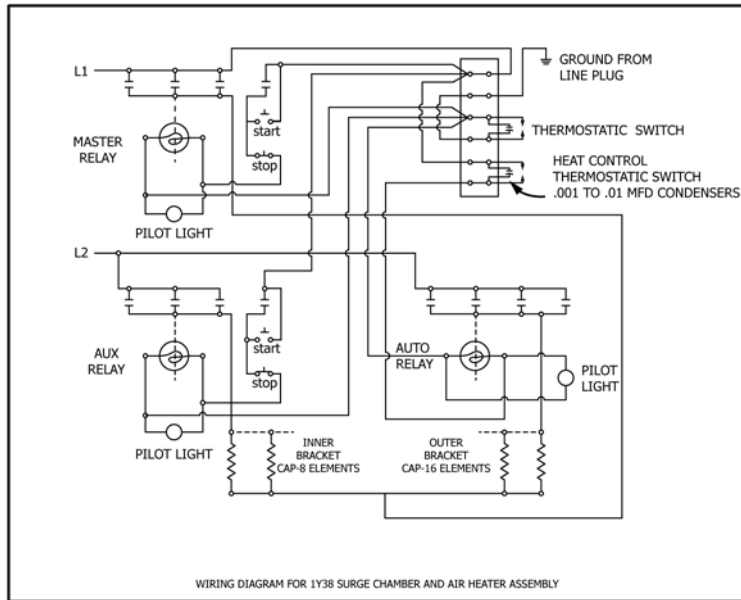

FIG. A1.25 Wiring Diagram for 1Y38 Surge Chamber and Air Heater Assembly

Air Transfer Pipe

1) The 1Y73 Engine Arrangement or the 1Y7500 Engine Arrangement modified with the 1Y7999 High Speed Change-Over Group requires an air transfer pipe as illustrated in Figs. A1.26-A1.29. It consists of two sections of 2 in. black iron pipe (or equivalent). The 1Y73 Flange, part of the section attached to the engine, is available as a standard part.

2) A slight bend may be made in one of the sections as long as the inner surface is not rippled and the inside circularity is not distorted. If a more pronounced bend is required, a 45° or 90° standard welding pipe fitting, illustrated in Fig. A1.27, is recommended. The centerline pipe distance of the temperature and pressure bosses from the flange face, shown in Figs. A1.28 and A1.29, should be maintained regardless of pipe curvature in this area.

3) To isolate the surge chamber from engine vibration the two sections are connected with a length of rubber hose as shown in Fig. A1.27. Any other suitable isolation device may be employed that has an inside diameter of 6.35 cm ± 1.3 cm (2.5 in. ± 0.5 in.) and does not alter the total pipe length of 76 cm ± 1.3 cm (31.25 in. ± 0.5 in.).

4) The 1Y7500 Engine Arrangement modified with the 1Y7630 Supercharger Change-Over Group uses an air transfer pipe identical to the one just described except for the flange on the section attached to the engine. The 1Y217 Flange shown in Fig. A1.29, available as a standard part, is used in constructing this section.

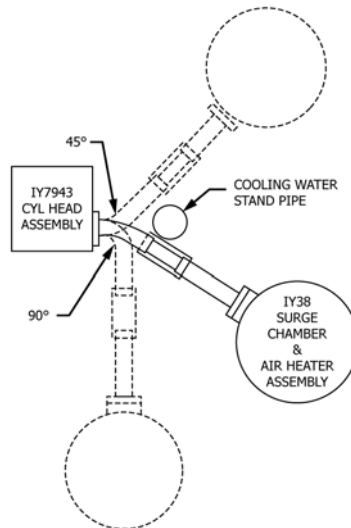
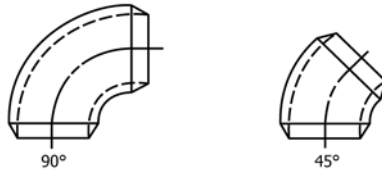

FIG. A1.26 Alternate Air Transfer Pipe Arrangements



STANDARD 2 IN. WELDING FITTINGS

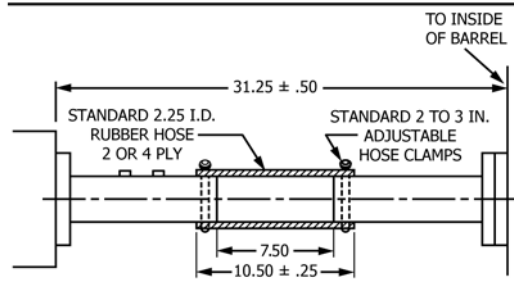

FIG. A1.27 Isolation Hose

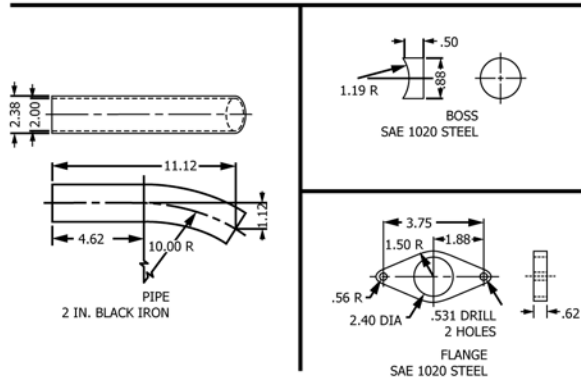
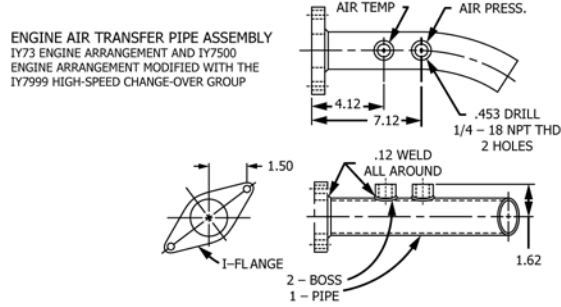

FIG. A1.28 Air Transfer Pipe

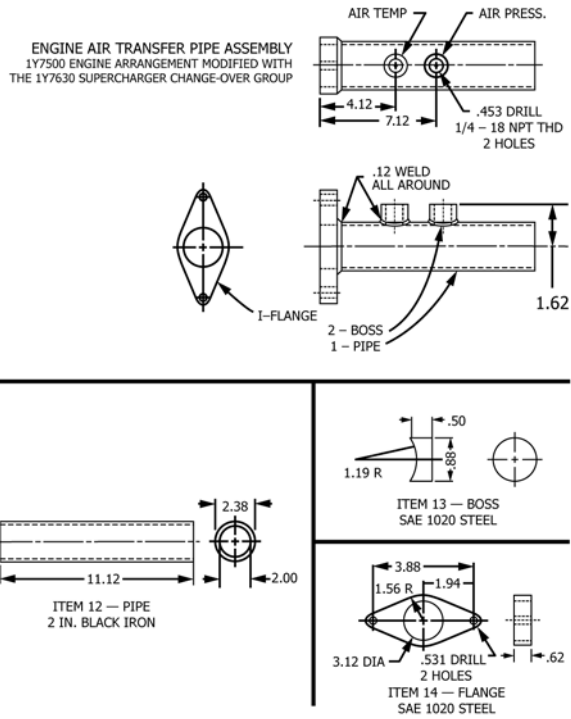

FIG. A1.28 Air Transfer Pipe (continued)

IY73 ENGINE ARRANGEMENT AND IY7500 ENGINE AR-
RANGEMENT MODIFIED WITH THE IY7999 HIGH-SPEED CHANGE-OVER GROUP

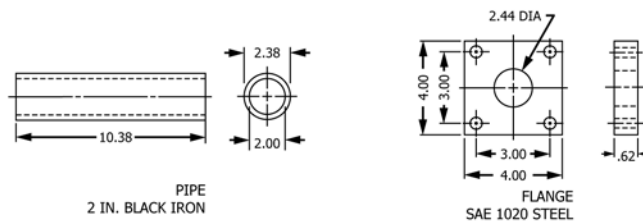
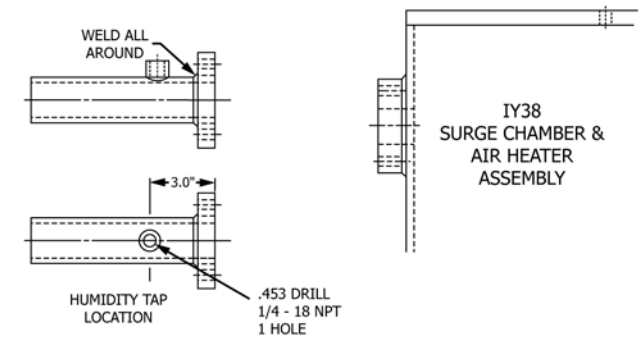
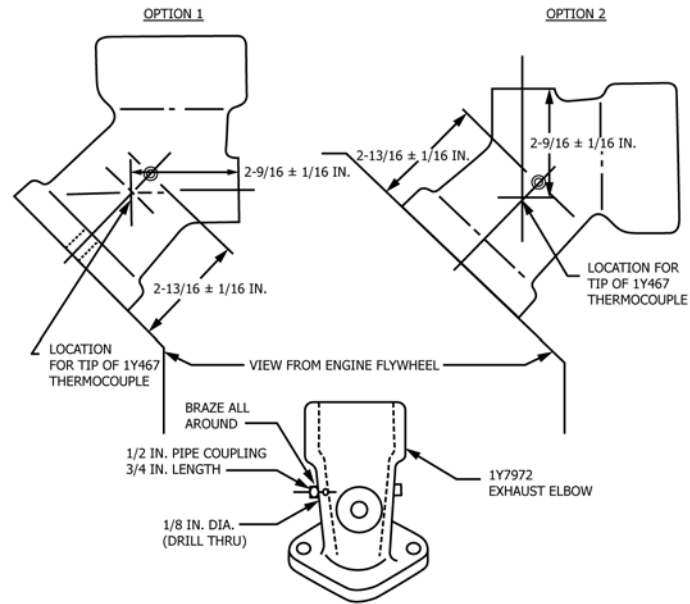
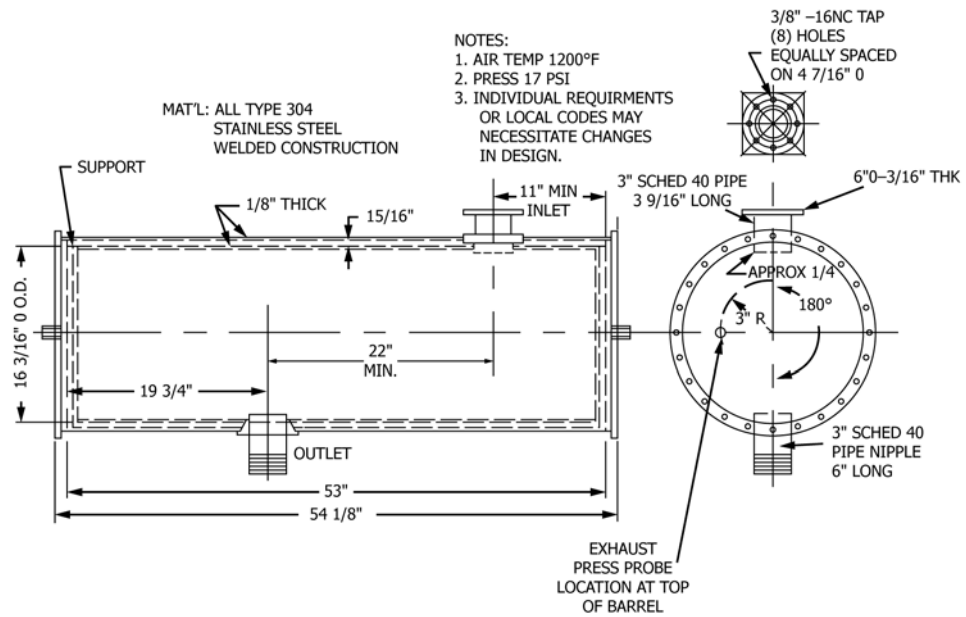

FIG. A1.29 Surge Chamber Outlet Pipe Assembly



COUPLING INSTALLATION

FIG. A1.30 Exhaust Thermocouple Location



ONE

FIG. A1.31 Exhaust Barrel Diagram

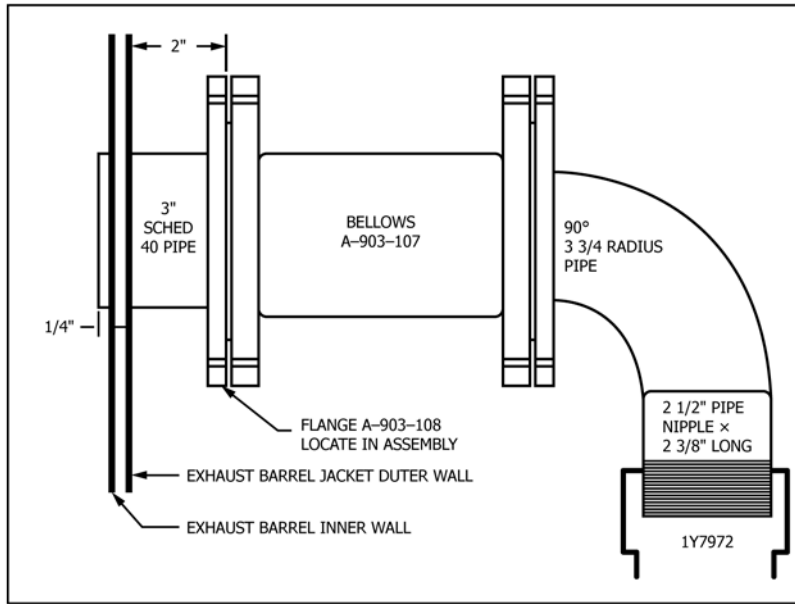

FIG. A1.32 Exhaust Piping

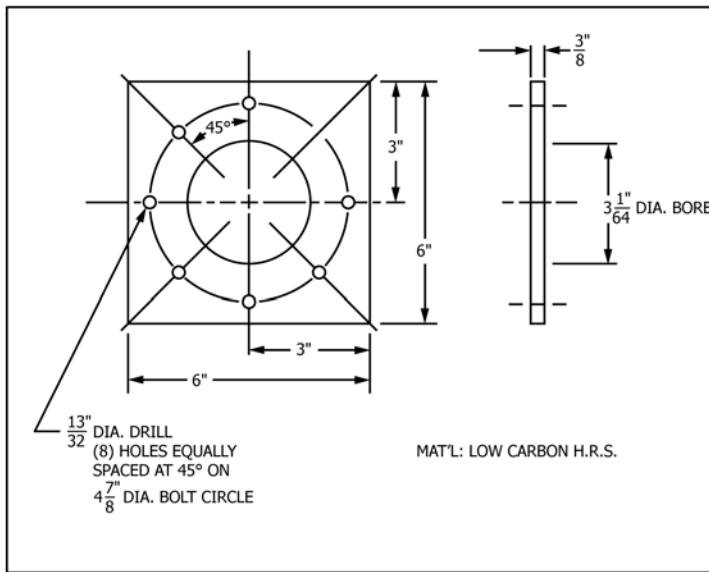

FIG. A1.33 Exhaust Barrel Flange

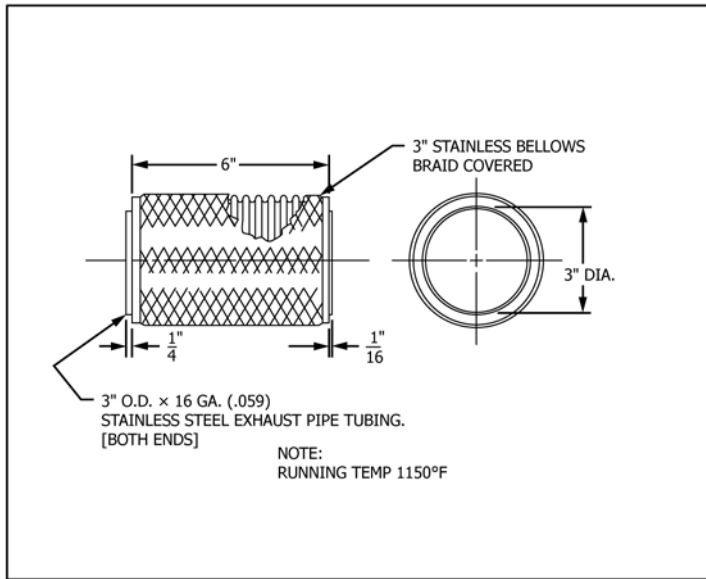

FIG. A1.34 Exhaust Bellows

This assembly is essentially a pressure vessel with internal electric heating elements. The general dimensions of the surge chamber are:

- Volume 209 L (7.37 ft³)
- Inside Diameter53 cm (21 in)
- Inside Height93 cm (36.75 in)

If individual requirements or local building codes necessitate changes in the design, the following modifications are permissible:

1. Volume may vary from seven to eight cubic feet.
2. Inside diameter may vary from 48 – 58 cm (19 to 23 in).
3. Inside height will be a function of the volume and inside diameter selected.
4. Inlet and outlet fittings may be located anywhere except directly opposite each other.
5. The type and arrangement of heating controls may be determined by local conditions.
6. The chamber may be located in any of a number of positions relative to the engine as long as:
 - (a) The length of the air transfer pipe is 76 ± 1.3 cm (31.25 ± 0.5 in) from the face of the surge chamber mounting pad to the inlet port face of the cylinder head.
 - (b) The air transfer pipe contains only one bend.
 - (c) The one bend shall not exceed 90 degrees.
7. A stand may be constructed to raise the chamber to the proper height depending upon the engine arrangement and mounting.

FIG. A1.35 1Y38 Surge Chamber and Air Heater Assembly

A2. REPORT FORMS

A2.1 Download report forms and data dictionary from the ASTM Test Monitoring Center (TMC) Web Page at: <http://www.astmtmc.cmu.edu/>. TMC can also provide hardcopies on request.

Report Form Table of Contents	
1. Final Report Cover Sheet	Cover
2. Test Report Summary	Form 1
3. Operational Summary	Form 2
4. Operational Summary – Offset and Deviation	Form 3
5. Piston Rating Summary	Form 4
6. Piston Rating Worksheet	Form 4a
7. Piston Rating Breakdown	Form 5
8. Referee Rating	Form 5a
9. CF-2 Rating	Form 6

Report Form Table of Contents	
10. Unscheduled Downtime & Maintenance Summary	Form 7
11. Ring Measurements	Form 8
12. Liner Measurements	Form 9
13. Characteristics of the Data Acquisition System	Form 10
14. Engine Operational Data Plots	Form 11
15. Engine Operational Data Plots (2)	Form 12
16. Oil Consumption Plot	Form 13
17. Piston and Ring Photographs	Form 14
18. Severity Adjustment History	Form 15
19. Fuel Batch Analysis	Form 16
20. TMC Control Chart Analysis	Form 17

NOTE A2.1—If the test will be submitted to the registration organization as a candidate oil, then use the same forms used for reporting reference test results and add the ACC Conformance Statement, Form 18.

A3. TEST FUEL INFORMATION

A3.1 Test Fuel Specifications and an Example of Required Fuel Batch Analysis Data is shown in Fig. A3.1.

LAB: OK	EOT DATE: 1980101	END TIME: 15:05
STAND: 3	RUN NUMBER: 34	
FORMULATION STAND CODE:		
OIL CODE/CMIR:		

Product: _____ Batch No.: _____
 TMC No.: _____
 TMO No.: _____
 Product Code: _____ Tank No.: _____
 Analysis Date: _____
 Shipment Date: _____

TEST	TEST METHOD	UNITS	SPECIFICATION			RESULTS
			MIN	TARGET	MAX	
Distillation - IBP	D86	°F		REPORT		
10%		°F		REPORT		
50%		°F	500		530	
90%		°F	590		620	
Distillation - EP		°F	650		690	
Gravity	D4052	°API	33.0		35.0	
Density	D4052	kg/m ³		REPORT		
Pour point	D97	°F			20	
Cloud point	D2500	°F		REPORT		
Flash point	D93	°F	140			
Viscosity, 40°C	D445	cSt	2.0		4.0	
Natural Sulfur	D4294	wt %	0.38		0.42	
Natural Sulfur	D2622	wt %		REPORT		
Composition, Aromatics	D1319	vol %		REPORT		
Composition, Olefins	D1319	vol %		REPORT		
Composition, Saturates	D1319	vol %		REPORT		
Cracked Stocks				None		
Basic sediment & water	D1796	vol %			0.1	
Ramsbottom carbon, 10% residue	D524	wt %			0.20	
Ash content	D482	wt %			0.01	
Acid Number	D664	mg KOH/g			0.15	
Copper Corrosion	D130				2	
Cetane Number	D613		47.0		53.0	
Aliphatic paraffins	D2425	wt %	45.0		65.0	
Monocycloparaffins	D2425	wt %		REPORT		
Dicycloparaffins	D2425	wt %	0.0		15.0	
Tricycloparaffins	D2425	wt %		REPORT		
Alkylbenzenes	D2425	wt %	5.0		10.0	
Indanes/Tetralins	D2425	wt %		REPORT		
Indenes	D2425	wt %		REPORT		
Napthalene	D2425	wt %		REPORT		
Napthalenes	D2425	wt %	5.0		15.0	
Acenaphthenes	D2425	wt %		REPORT		
Acenaphthalenes	D2425	wt %		REPORT		
Tricyclic aromatics	D2425	wt %		REPORT		

Approved by: _____ Analyst: _____

FIG. A3.1 Test Fuel Batch Analysis

APPENDIXES

(Nonmandatory Information)

X1. CORRECTION FACTOR TABLES

X1.1 See **Tables X1.1-X1.8** for humidity correction factors.

where:

- 7000 = number of grains per pound,
- M_v = molecular weight of water vapor,
- M_a = molecular weight of dry air,
- P_v = partial pressure of water vapor at dew point, and
- P_T = total pressure at point of humidity measurement.

X1.2 The following calculations are an example of a perfect gas law equation for corrected humidity:

$$\text{or Humidity} = 7000 \left[\frac{18.0152}{28.96247} \right] \frac{P_v}{(P_T - P_v)} \quad (\text{X1.1})$$

$$\text{or Humidity} = 4354.13 \frac{P_v}{(P_T - P_v)} \quad (\text{X1.2})$$

X1.3 See **Table X1.9** for Smithsonian tables for saturation vapor pressure over water.

**TABLE X1.1 Humidity, Grains/Pound Correction Factors
for Non-standard Barometric Conditions (30.0 in. Hg to 30.9 in. Hg)**

Dew Point Temp °F	Barometric Pressure (in. Hg)									
	30.9	30.8	30.7	30.6	30.5	30.4	30.3	30.2	30.1	30.0
65	-3.1	-2.8	-2.5	-2.2	-1.9	-1.6	-1.2	-0.9	-0.6	-0.3
66	-3.2	-2.9	-2.6	-2.2	-1.9	-1.6	-1.3	-1.0	-0.6	-0.3
67	-3.3	-3.0	-2.6	-2.3	-2.0	-1.7	-1.3	-1.0	-0.7	-0.3
68	-3.4	-3.1	-2.7	-2.4	-2.0	-1.7	-1.4	-1.0	-0.7	-0.3
69	-3.5	-3.2	-2.8	-2.5	-2.1	-1.8	-1.4	-1.1	-0.7	-0.4
70	-3.7	-3.3	-3.0	-2.6	-2.2	-1.9	-1.5	-1.1	-0.7	-0.4
71	-3.8	-3.4	-3.0	-2.7	-2.3	-1.9	-1.5	-1.1	-0.8	-0.4
72	-3.9	-3.5	-3.1	-2.7	-2.3	-2.0	-1.6	-1.2	-0.8	-0.4
73	-4.1	-3.7	-3.3	-2.9	-2.5	-2.1	-1.6	-1.2	-0.8	-0.4
74	-4.2	-3.8	-3.4	-2.9	-2.5	-2.1	-1.7	-1.3	-0.8	-0.4
75	-4.4	-4.0	-3.5	-3.1	-2.6	-2.2	-1.8	-1.3	-0.9	-0.4
76	-4.5	-4.1	-3.6	-3.2	-2.7	-2.3	-1.8	-1.4	-0.9	-0.5
77	-4.7	-4.2	-3.8	-3.3	-2.8	-2.4	-1.9	-1.4	-0.9	-0.5
78	-4.9	-4.4	-3.9	-3.4	-2.9	-2.5	-2.0	-1.5	-1.0	-0.5
79	-5.0	-4.5	-4.0	-3.5	-3.0	-2.5	-2.0	-1.5	-1.0	-0.5
80	-5.2	-4.7	-4.2	-3.6	-3.1	-2.6	-2.1	-1.6	-1.0	-0.5

**TABLE X1.2 Humidity, Grains/Pound Correction Factors
for Non-standard Barometric Conditions (29.0 in. Hg to 29.9 in. Hg)**

Dew Point Temp °F	Barometric Pressure (in. Hg)									
	29.9	29.8	29.7	29.6	29.5	29.4	29.3	29.2	29.1	29.0
65	0.0	0.3	0.7	1.0	1.3	1.7	2.0	2.3	2.6	3.0
66	0.0	0.3	0.7	1.0	1.4	1.7	2.0	2.4	2.7	3.1
67	0.0	0.4	0.7	1.1	1.4	1.8	2.1	2.5	2.8	3.2
68	0.0	0.4	0.7	1.1	1.5	1.9	2.2	2.6	3.0	3.3
69	0.0	0.4	0.8	1.1	1.5	1.9	2.3	2.7	3.0	3.4
70	0.0	0.4	0.8	1.2	1.6	2.0	2.3	2.7	3.1	3.5
71	0.0	0.4	0.8	1.2	1.6	2.1	2.5	2.9	3.3	3.7
72	0.0	0.4	0.8	1.3	1.7	2.1	2.5	2.9	3.4	3.8
73	0.0	0.4	0.9	1.3	1.8	2.2	2.6	3.1	3.5	4.0
74	0.0	0.5	0.9	1.4	1.8	2.3	2.8	3.2	3.7	4.1
75	0.0	0.5	0.9	1.4	1.9	2.4	2.8	3.3	3.8	4.2
76	0.0	0.5	1.0	1.5	2.0	2.5	2.9	3.4	3.9	4.4
77	0.0	0.5	1.0	1.5	2.0	2.6	3.1	3.6	4.1	4.6
78	0.0	0.5	1.0	1.6	2.1	2.6	3.1	3.6	4.2	4.7
79	0.0	0.5	1.1	1.6	2.2	2.7	3.2	3.8	4.3	4.9
80	0.0	0.6	1.1	1.7	2.2	2.8	3.4	3.0	4.5	5.0

**TABLE X1.3 Humidity, Grains/Pound Correction Factors
for Non-standard Barometric Conditions (28.0 in. Hg to 28.9 in. Hg)**

Dew Point Temp °F	Barometric Pressure (in. Hg)									
	28.9	28.8	28.7	28.6	28.5	28.4	28.3	28.2	28.1	28.0
65	3.3	3.7	4.0	4.4	4.7	5.1	5.4	5.8	6.1	6.5
66	3.4	3.8	4.1	4.5	4.9	5.3	5.6	6.0	6.4	6.7
67	3.5	3.9	4.3	4.6	5.0	5.4	5.8	6.2	6.5	6.9
68	3.7	4.1	4.5	4.9	5.3	5.7	6.0	6.4	6.8	7.2
69	3.8	4.2	4.6	5.0	5.4	5.9	6.3	6.7	7.1	7.5
70	3.9	4.3	4.7	5.2	5.6	6.0	6.4	6.8	7.3	7.7
71	4.1	4.5	5.0	5.4	5.8	6.3	6.7	7.1	7.5	8.0
72	4.2	4.7	5.1	5.6	6.0	6.5	6.9	7.4	7.8	8.3
73	4.4	4.9	5.3	5.8	6.2	6.7	7.2	7.6	8.1	8.5
74	4.6	5.1	5.6	6.0	6.5	7.0	7.5	8.0	8.4	8.9
75	4.7	5.2	5.7	6.2	6.7	7.2	7.7	8.2	8.7	9.2
76	4.9	5.4	5.9	6.4	6.9	7.5	8.0	8.5	9.0	9.5
77	5.1	5.6	6.2	6.7	7.2	7.8	8.3	8.8	9.3	9.9
78	5.2	5.8	6.3	6.9	7.4	8.0	8.6	9.1	9.7	10.2
79	5.4	6.0	6.6	7.1	7.7	8.3	8.9	9.5	10.0	10.6
80	5.6	6.2	6.8	7.4	8.0	8.6	9.2	9.8	10.4	11.0

**TABLE X1.4 Humidity, Grains/Pound Correction Factors
for Non-standard Barometric Conditions (27.0 in. Hg to 27.9 in. Hg)**

Dew Point Temp °F	Barometric Pressure (in. Hg)									
	27.9	27.8	27.7	27.6	27.5	27.4	27.3	27.2	27.1	27.0
65	6.8	7.2	7.5	7.9	8.2	8.6	8.9	9.3	9.6	10.0
66	7.1	7.5	7.9	8.3	8.7	9.1	9.4	9.8	10.2	10.6
67	7.3	7.7	8.1	8.5	8.9	9.4	9.8	10.2	10.6	11.0
68	7.6	8.0	8.4	8.9	9.3	9.7	10.1	10.5	11.0	11.4
69	7.9	8.3	8.8	9.2	9.6	10.1	10.5	10.9	11.3	11.8
70	8.1	8.6	9.0	9.5	9.9	10.4	10.9	11.3	11.8	12.2
71	8.1	8.9	9.3	9.8	10.3	10.8	11.2	11.7	12.2	12.6
72	8.7	9.2	9.7	10.2	10.7	11.2	11.6	12.1	12.6	13.1
73	9.0	9.5	10.0	10.5	11.0	11.6	12.1	12.6	13.1	13.6
74	9.4	9.9	10.4	11.0	11.5	12.0	12.5	13.0	13.6	14.1
75	9.7	10.2	10.8	11.3	11.9	12.4	12.9	13.5	14.0	14.6
76	10.0	10.6	11.1	11.7	12.3	12.9	13.4	14.0	14.6	15.1
77	10.4	11.0	11.6	12.2	12.8	13.4	13.9	14.5	15.1	15.7
78	10.8	11.4	12.0	12.6	13.2	13.9	14.5	15.1	15.7	16.3
79	11.2	11.8	12.5	13.1	13.7	14.4	15.0	15.6	16.2	16.9
80	11.6	12.3	12.9	13.6	14.2	14.9	15.5	16.2	16.8	17.5

TABLE X1.5 Humidity, Grams/Kilogram Correction Factors (101.6 kPa to 104.6 kPa)

Dew Point Temp °C	Barometric Pressure (kPa)									
	104.6	104.3	104.0	103.6	103.3	102.9	102.6	102.1	101.9	101.6
18.3	-0.44	-0.40	-0.36	-0.32	-0.27	-0.23	-0.17	-0.13	-0.09	-0.04
18.9	-0.46	-0.41	-0.37	-0.32	-0.27	-0.23	-0.19	-0.14	-0.09	-0.04
19.4	-0.47	-0.43	-0.37	-0.33	-0.29	-0.24	-0.19	-0.14	-0.10	-0.04
20.0	-0.49	-0.44	-0.39	-0.34	-0.29	-0.24	-0.20	-0.14	-0.10	-0.04
20.6	-0.50	-0.46	-0.40	-0.36	-0.30	-0.26	-0.20	-0.16	-0.10	-0.06
21.1	-0.53	-0.47	-0.43	-0.37	-0.32	-0.27	-0.21	-0.16	-0.10	-0.06
21.7	-0.54	-0.49	-0.43	-0.39	-0.33	-0.27	-0.21	-0.16	-0.11	-0.06
22.2	-0.56	-0.50	-0.44	-0.39	-0.33	-0.29	-0.23	-0.17	-0.11	-0.06
22.8	-0.59	-0.53	-0.47	-0.41	-0.36	-0.30	-0.23	-0.17	-0.11	-0.06
23.3	-0.60	-0.54	-0.49	-0.41	-0.36	-0.30	-0.24	-0.19	-0.11	-0.06
23.9	-0.63	-0.57	-0.50	-0.44	-0.37	-0.31	-0.26	-0.19	-0.13	-0.06
24.4	-0.64	-0.59	-0.51	-0.46	-0.39	-0.33	-0.26	-0.20	-0.13	-0.07
25.0	-0.67	-0.60	-0.54	-0.47	-0.40	-0.34	-0.27	-0.20	-0.13	-0.07
25.6	-0.70	-0.63	-0.56	-0.49	-0.41	-0.36	-0.29	-0.21	-0.14	-0.07
26.1	-0.72	-0.64	-0.57	-0.50	-0.43	-0.36	-0.29	-0.21	-0.14	-0.07
26.7	-0.74	-0.67	-0.60	-0.51	-0.44	-0.37	-0.30	-0.23	-0.14	-0.07

TABLE X1.6 Humidity, Grams/Kilogram Correction Factors (98.2 kPa to 101.2 kPa)

Dew Point Temp °C	Barometric Pressure (kPa)									
	101.2	100.9	100.6	100.2	99.9	99.5	99.2	98.9	98.5	98.2
18.3	0	0.04	0.10	0.14	0.19	0.24	0.29	0.33	0.37	0.43
18.9	0	0.04	0.10	0.14	0.20	0.24	0.29	0.34	0.39	0.44
19.4	0	0.06	0.10	0.16	0.20	0.26	0.30	0.36	0.40	0.46
20.0	0	0.06	0.10	0.16	0.21	0.27	0.32	0.37	0.43	0.47
20.6	0	0.06	0.11	0.16	0.21	0.27	0.33	0.39	0.43	0.49
21.1	0	0.06	0.11	0.17	0.23	0.29	0.33	0.39	0.44	0.50
21.7	0	0.06	0.11	0.17	0.23	0.30	0.36	0.41	0.47	0.53
22.2	0	0.06	0.11	0.19	0.24	0.30	0.36	0.41	0.49	0.54
22.8	0	0.06	0.13	0.19	0.26	0.32	0.37	0.44	0.50	0.57
23.3	0	0.07	0.13	0.20	0.26	0.33	0.40	0.46	0.53	0.59
23.9	0	0.07	0.13	0.20	0.27	0.34	0.40	0.47	0.54	0.60
24.4	0	0.07	0.14	0.21	0.29	0.36	0.41	0.49	0.56	0.63
25.0	0	0.07	0.14	0.21	0.29	0.37	0.44	0.51	0.59	0.66
25.6	0	0.07	0.14	0.23	0.30	0.37	0.44	0.51	0.60	0.67
26.1	0	0.07	0.16	0.23	0.32	0.39	0.46	0.54	0.61	0.70
26.7	0	0.09	0.16	0.24	0.32	0.40	0.49	0.56	0.64	0.72

TABLE X1.7 Humidity, Grams/Kilogram Correction Factors (94.8 kPa to 97.9 kPa)

Dew Point Temp °C	Barometric Pressure (kPa)									
	97.9	97.5	97.2	96.8	96.5	96.2	95.8	95.5	95.2	94.8
18.3	0.47	0.53	0.57	0.63	0.67	0.73	0.77	0.83	0.87	0.93
18.9	0.49	0.54	0.59	0.65	0.70	0.76	0.80	0.86	0.92	0.96
19.4	0.50	0.56	0.61	0.66	0.72	0.77	0.83	0.89	0.93	0.99
20.0	0.53	0.59	0.64	0.70	0.76	0.82	0.86	0.92	0.97	1.03
20.6	0.54	0.60	0.66	0.72	0.77	0.84	0.90	0.96	1.02	1.07
21.1	0.56	0.61	0.67	0.74	0.80	0.86	0.92	0.97	1.04	1.10
21.7	0.59	0.64	0.72	0.77	0.83	0.90	0.96	1.02	1.07	1.14
22.2	0.60	0.67	0.73	0.80	0.86	0.93	0.99	1.06	1.12	1.19
22.8	0.63	0.70	0.76	0.83	0.89	0.96	1.03	1.09	1.16	1.22
23.3	0.66	0.73	0.80	0.86	0.93	1.00	1.07	1.14	1.20	1.27
23.9	0.67	0.74	0.82	0.89	0.96	1.03	1.10	1.17	1.24	1.32
24.4	0.70	0.77	0.84	0.92	0.99	1.07	1.14	1.22	1.29	1.36
25.0	0.73	0.80	0.89	0.96	1.03	1.12	1.19	1.26	1.33	1.42
25.6	0.74	0.83	0.90	0.99	1.06	1.14	1.23	1.30	1.39	1.46
26.1	0.77	0.86	0.94	1.02	1.10	1.19	1.27	1.36	1.43	1.52
26.7	0.80	0.89	0.97	1.06	1.14	1.23	1.32	1.40	1.49	1.57

TABLE X1.8 Humidity, Grams/Kilogram Correction Factors (91.4 kPa to 94.5 kPa)

Dew Point Temp °C	Barometric Pressure (kPa)									
	94.5	94.1	93.8	93.5	93.1	92.8	92.4	92.1	91.7	91.4
18.3	0.97	1.03	1.07	1.13	1.17	1.23	1.27	1.33	1.37	1.43
18.9	1.02	1.07	1.13	1.19	1.24	1.30	1.34	1.40	1.46	1.52
19.4	1.04	1.10	1.16	1.22	1.27	1.34	1.40	1.46	1.52	1.57
20.0	1.09	1.14	1.20	1.27	1.33	1.39	1.44	1.50	1.57	1.63
20.6	1.13	1.19	1.26	1.32	1.37	1.44	1.50	1.56	1.62	1.69
21.1	1.16	1.23	1.29	1.36	1.42	1.49	1.56	1.62	1.69	1.74
21.7	1.16	1.27	1.33	1.40	1.47	1.54	1.60	1.67	1.74	1.80
22.2	1.24	1.32	1.39	1.46	1.53	1.60	1.66	1.73	1.80	1.87
22.8	1.29	1.36	1.43	1.50	1.57	1.66	1.73	1.80	1.87	1.94
23.3	1.34	1.42	1.49	1.57	1.64	1.72	1.79	1.86	1.94	2.02
23.9	1.39	1.46	1.54	1.62	1.70	1.77	1.84	1.93	2.00	2.09
24.4	1.43	1.52	1.59	1.67	1.76	1.84	1.92	2.00	2.09	2.16
25.0	1.49	1.57	1.66	1.74	1.83	1.92	1.99	2.07	2.16	2.25
25.6	1.54	1.63	1.72	1.80	1.89	1.99	2.07	2.16	2.25	2.33
26.1	1.60	1.69	1.79	1.87	1.96	2.06	2.15	2.23	2.32	2.42
26.7	1.66	1.76	1.84	1.94	2.03	2.13	2.22	2.32	2.40	2.50

TABLE X1.9 Saturation Vapor Pressure Over Water (Smithsonian Tables)^A

Dew Point Temp °F	Vapor Press. in. Hg	Dew Point Temp °F	Vapor Press. in. Hg
60	0.52160	75	0.87506
61	0.54047	76	0.90472
62	0.55994	77	0.93524
63	0.58002	78	0.96666
64	0.60073	79	0.99900
65	0.62209	80	1.03230
66	0.64411	81	1.06650
67	0.66681	82	1.10170
68	0.69021	83	1.13800
69	0.71432	84	1.17520
70	0.73916	85	1.21360
71	0.76467	86	1.25300
72	0.79113	87	1.29350
73	0.81829	88	1.33510
74	0.84626	89	1.37790

^AReprinted from *Selecting Humidity Sensors for Industrial Processes Handbook*, General Eastern Instrument Corp., March, 1982.

X2. REPORT FORMS

X2.1 Examples of report forms making up the 1M-PC final report are shown in [Figs. X2.1 and X2.2](#).

LAB: OK	EOT DATE: 1980101	END TIME: 15:05
STAND: 3	RUN NUMBER: 34	
FORMULATION STAND CODE:		
OIL CODE/CMIR:		

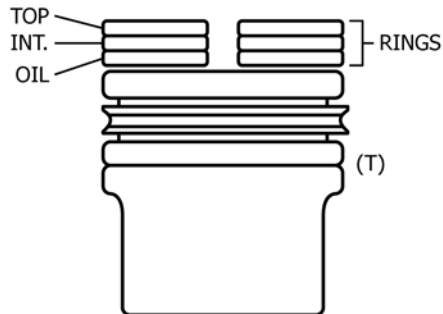
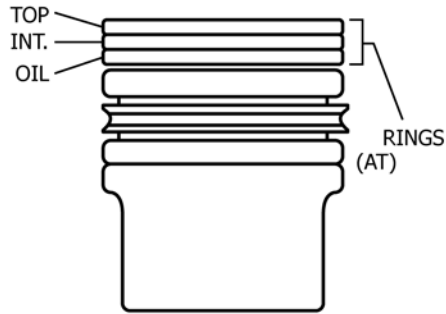

SHOW SKIRT FROM BOTTOM OF PIN
BORE TO TOP OF PISTON

FIG. X2.1 Form 14 (Example)—Piston and Ring Photographs

LAB: OK	EOT DATE: 1980101	END TIME: 15:05
STAND: 3	RUN NUMBER: 34	
FORMULATION STAND CODE:		
OIL CODE/CMIR:		

Fax To: JOE ENGINEER
 Company: OK OIL TEST LAB
 Fax Number: 800-555-1212

**** ASTM Test Monitoring Center ****
 ***** CATERPILLAR 1MPC Control Chart Analysis *****

RDTSTRT 19971212
 RDTCOMP 19971218
 EOTTIME 21:45
 LTMSDATE 19971218
 LTMSTIME 21:45

LAB = OK
 STAND = 2
 ENRUN = 44
 DTERPT = 19971219

CMIR = 12345
 IND = 873-1

Parameter	Reported Value	Transformed Value	Targets Effective 19940419 to ***		Analysis Compiled: 29JAN98 15:03:28
			Mean	\$	
TGF	68	68.000	41.000	16.10	Note: When two limits are given, the upper is the Warning Limit and the lower is the Action Limit.
WTD	227.9	227.90	232.50	50.500	

Key: A - Action alarm
 W - Warning alarm

	EWMA				STAND ANALYSIS				Shewhart				
	N	Z(I)	Severity Limit	Alarm	Q(I)	Precision Limit	Alarm	Y(I)	Severity Limit	Alarm	R(I)	Precision Limit	Alarm
TGF	6	1.776	±0.861	A	-0.641	+0.731		1.477	±1.750		-0.253	+1.740	
WTD	6	-0.018	±0.861		-0.145	+0.731		-0.041	±1.750		-0.548	+1.740	

	EWMA				LABORATORY ANALYSIS				Shewhart				
	N	Z(I)	Severity Limit	Alarm	Q(I)	Precision Limit	Alarm	Y(I)	Severity Limit	Alarm	R(I)	Precision Limit	Alarm
TGF	52	1.116	±0.653	SA	0.292	+0.860 +0.580		1.477	±1.750		1.831	+1.740	A
WTD	52	0.219	±0.653		-0.244	+0.860		-0.041	±1.750		-0.591	+1.740	

*** Laboratory Level Severity Adjustments ***
 TGFsa = -14 WTDsa = 0.0

STAND is Calibrated: YES NO (Circle Required)

Calibration Expiration Date: _____ or 14 Tests

* TMC Validity Code: _____

_____ STAND PULLED FROM LTMS (Check Required) Reviewer Initials: _____

* Based on review of call-in report of operational data and LTMS analysis shown above.

FIG. X2.2 Form 17 (Example)—TMC Control Chart Analysis

X3. 1M-PC MULTIPLE TESTING

X3.1 If testing candidate lubricants in accordance with Specification **D4485**, the results of multiple testing should be reported on the form shown as **Fig. X3.1**.

OIL CODE NO. _____											
				ENGINE			LAB UNADJUSTED RATING		LAB SA ADJUSTED		RING SIDE
TEST NO.	DATE TEST COMP.	OIL CODE NO.	TEST LAB	SERIAL NO.	STAND NO.	RUN NO.	WTD	TGF	WTD	TGF	CLEAR. LOSS (mm)
1 ST											
2											
3											
4											
TEST AVERAGE											
1 ST											
2											
3											
4											
2 TEST AVERAGE WITH OUTLIER REMOVED											
3 TEST AVERAGE WITH OUTLIER REMOVED											

FIG. X3.1 1M-PC Multiple Test Data Summary Sheet

SUMMARY OF CHANGES

Subcommittee D02.B0 has identified the location of selected changes to this standard since the last issue (D6618 – 14) that may impact the use of this standard. (Approved April 1, 2016.)

(1) Subsection **12.16** revised to delete the requirement for test validation.

ASTM International takes no position respecting the validity of any patent rights asserted in connection with any item mentioned in this standard. Users of this standard are expressly advised that determination of the validity of any such patent rights, and the risk of infringement of such rights, are entirely their own responsibility.

This standard is subject to revision at any time by the responsible technical committee and must be reviewed every five years and if not revised, either reapproved or withdrawn. Your comments are invited either for revision of this standard or for additional standards and should be addressed to ASTM International Headquarters. Your comments will receive careful consideration at a meeting of the responsible technical committee, which you may attend. If you feel that your comments have not received a fair hearing you should make your views known to the ASTM Committee on Standards, at the address shown below.

This standard is copyrighted by ASTM International, 100 Barr Harbor Drive, PO Box C700, West Conshohocken, PA 19428-2959, United States. Individual reprints (single or multiple copies) of this standard may be obtained by contacting ASTM at the above address or at 610-832-9585 (phone), 610-832-9555 (fax), or service@astm.org (e-mail); or through the ASTM website (www.astm.org). Permission rights to photocopy the standard may also be secured from the Copyright Clearance Center, 222 Rosewood Drive, Danvers, MA 01923, Tel: (978) 646-2600; http://www.copyright.com/