



Standard Test Method for Evaluation of Rust Preventive Characteristics of Automotive Engine Oils¹

This standard is issued under the fixed designation D6557; the number immediately following the designation indicates the year of original adoption or, in the case of revision, the year of last revision. A number in parentheses indicates the year of last reapproval. A superscript epsilon (ϵ) indicates an editorial change since the last revision or reapproval.

1. Scope*

1.1 This test method covers a Ball Rust Test (BRT) procedure for evaluating the anti-rust ability of fluid lubricants. The procedure is particularly suitable for the evaluation of automotive engine oils under low-temperature, acidic service conditions.

1.2 Information Letters are published occasionally by the ASTM Test Monitoring Center (TMC)² to update this test method. Copies of these letters can be obtained by writing the center.

1.3 The values stated in SI units are to be regarded as standard. No other units of measurement are included in this standard.

1.3.1 *Exceptions*—Where there is no direct equivalent, such as the units for screw threads, national pipe threads/diameters, and tubing size.

1.4 *This standard does not purport to address all of the safety concerns, if any, associated with its use. It is the responsibility of the user of this standard to establish appropriate safety and health practices and determine the applicability of regulatory limitations prior to use. See 7.1.1 – 7.1.3 and 8.2.1.1.*

2. Referenced Documents

2.1 ASTM Standards:³

D4175 Terminology Relating to Petroleum, Petroleum Products, and Lubricants

¹ This test method is under the jurisdiction of ASTM Committee D02 on Petroleum Products, Liquid Fuels, and Lubricants and is the direct responsibility of Subcommittee D02.B0.01 on Passenger Car Engine Oils.

Current edition approved May 1, 2013. Published May 2013. Originally approved in 2000. Last previous edition approved in 2010 as D6557 – 10a. DOI: 10.1520/D6557-13.

² Until the next revision of this test method, the ASTM Test Monitoring Center will update changes in the test method by means of information letters. Information letters may be obtained from the ASTM Test Monitoring Center, 6555 Penn Avenue, Pittsburgh, PA 15206-4489. This test method is supplemented by Information Letters and Memoranda issued by the ASTM TMC. This edition incorporates revisions in all Information Letters through No. 07–01.

³ For referenced ASTM standards, visit the ASTM website, www.astm.org, or contact ASTM Customer Service at service@astm.org. For *Annual Book of ASTM Standards* volume information, refer to the standard's Document Summary page on the ASTM website.

D5844 Test Method for Evaluation of Automotive Engine Oils for Inhibition of Rusting (Sequence IID) (Withdrawn 2003)⁴

3. Terminology

3.1 Definitions:

3.1.1 *calibrate, v*—to determine the indication or output of a device (e.g., thermometer, manometer, engine) with respect to a standard.

3.1.2 *corrosion, n*—the chemical or electrochemical reaction between a material, usually a metal surface, and its environment that can produce a deterioration of the material and its properties. **D4175**

3.1.3 *non-reference oil, n*—any oil other than a reference oil, such as a research formulation, commercial oil, or candidate oil. **D4175**

3.1.4 *reference oil, n*—an oil of known performance characteristics, used as a basis for comparison. **D4175**

3.1.4.1 *Discussion*—Reference oils are used to calibrate testing facilities, to compare the performance of other oils, or to evaluate other materials (such as seals) that interact with oils.

3.1.5 *rust (coatings), n*—of iron or its alloys, a corrosion product consisting of hydrated iron oxides, usually reddish in color but can also be brown-to-black.

3.1.6 *test oil, n*—any oil subjected to evaluation in an established procedure.

3.2 Definitions of Terms Specific to This Standard:

3.2.1 *average gray value (AGV), n*—measurement of brightness units on test specimens, indicating the degree of rust protection.

3.2.2 *specimen, n*—a carbon steel ball, 5.6 mm (AISI 1040).

4. Summary of Test Method

4.1 Multiple test tubes, each containing test oil and a specimen, are placed in a test tube rack that is attached to a mechanical shaker. The shaker speed and temperature are controlled.

⁴ The last approved version of this historical standard is referenced on www.astm.org.

*A Summary of Changes section appears at the end of this standard

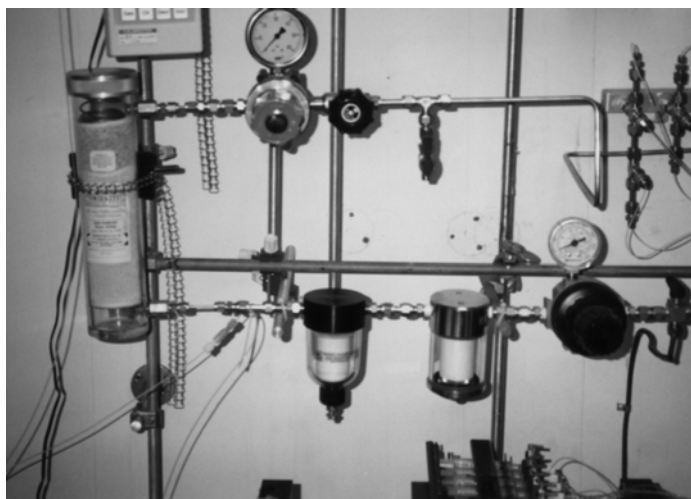

FIG. 1 Photograph of Air Delivery System

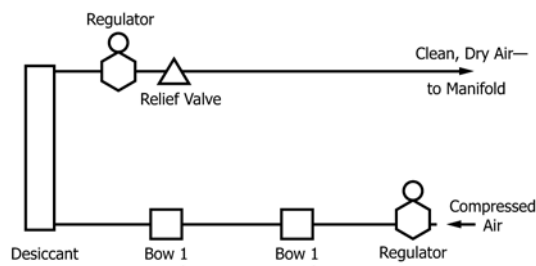

FIG. 2 Schematic of Air Delivery System

4.2 Air and an acidic solution are continuously fed into each test tube over an 18 h period to create a corrosive environment.

4.3 The specimens are then removed, rinsed, and analyzed by an optical imaging system designed to quantify the antirust capability of each test oil.

5. Significance and Use

5.1 This bench test method was designed as a replacement for Test Method D5844. Test Method D5844 was designed to measure the ability of an engine oil to protect valve train components against rusting or corrosion under low temperature, short-trip service, and was correlated with vehicles in that type of service prior to 1978.⁵

5.1.1 Correlation between these two test methods has been demonstrated for most, but not all, of the test oils evaluated.

6. Apparatus

6.1 *Specimen Preparation System*—Obtain the specimens from the Central Parts Distributor (CPD).^{6,7}

6.1.1 Specimen preparation equipment includes various common laboratory apparatus and an ultrasonic cleaning bath.

6.2 *Air Supply System*—A compressed air supply is required, with two air filters, two pressure regulators, a gas purifier, a gassing manifold (25 port outlet), TFE-fluorocarbon tubing (25 lengths, each 183 m) or equivalent multiport flow control system, and a calibrated flowmeter (see Annex A1 and Figs. 1 and 2).

6.3 *Acid Solution Delivery System*—An acid solution delivery system that includes a multiple syringe pump with a ten position rack is required. The flow rate range minimum, using

a 0.5 μL syringe, is 0.0001 $\mu\text{L}/\text{h}$. The flow rate maximum, using a 140 mL syringe, is 220.82 mL/min (see Figs. 3 and 4).

6.4 *Test Tube Assembly*—The test tube assembly consists of 24 disposable plastic syringes and other common laboratory apparatus.

6.5 *Temperature and Shaking Speed Control System*—A mechanical shaker, Bench-Top Environ Shaker Model 4628,^{7,8} provides an orbital shaking motion in a controlled speed and temperature environment.

6.5.1 A special test tube assembly rack^{7,9} (see Figs. 5 and 6) has 24 tube positions and is attached to the shaker platform (457 by 457) mm.

6.6 *Air Delivery Manifold*, required.

6.7 *Venting System*—Common laboratory apparatus is employed for the required venting system (see Fig. 7).

6.8 *Image Analysis System*—A specific imaging analysis system^{7,10} is required. This system is composed of:

6.8.1 *Optics and Illumination*:

6.8.1.1 Nikon Epiphot 200 inverted metallurgical microscope,

6.8.1.2 BZ binocular head,

6.8.1.3 RV 3 plate mechanical stage,

6.8.1.4 CFWN 10 \times wide field eyepiece, high point eyepiece,

6.8.1.5 Manual BD 5 place nosepiece,

6.8.1.6 Epiphot 300 EB block,

6.8.1.7 DF module,

6.8.1.8 CF BD plan 5 \times /0.13 plan achromat objective,

6.8.1.9 CF BD plan 10 \times /0.13 plan achromat objective,

6.8.1.10 EPI polarizer,

6.8.1.11 Analyzer,

6.8.1.12 Lamphouse for 12 V/100 W quartz halogen light source,

6.8.1.13 Lamphouse adapter,

6.8.1.14 12 V/100 W halogen bulbs,

6.8.1.15 300/200 100 W power supply,

6.8.1.16 Remote control cable,

6.8.1.17 C-mount coupler for video camera,

6.8.1.18 NCB 11 filter,

⁵ Special Technical Publication, "Multicylinder Test Sequences for Evaluating Automotive Engine Oils," Part, Sequence IIID ASTM STP 315H, Available from ASTM Headquarters.

⁶ The sole source of supply of the apparatus known to the committee at this time is Central Parts Distributor, Test Engineering Inc., 12718 Cimmaron Path, San Antonio, TX 78249.

⁷ If you are aware of alternative suppliers, please provide this information to ASTM Headquarters. Your comments will receive careful consideration at a meeting of the responsible technical committee, which you may attend.

⁸ The sole source of supply of the apparatus known to the committee at this time is Labine, Inc., 15th and Bloomingdale, Melrose Park, IL 60160.

⁹ The sole source of supply of the apparatus known to the committee at this time is West End Machine and Weld, Inc., P.O. Box 9444, Richmond, VA 23228.

¹⁰ The sole source of supply of the apparatus known to the committee at this time is Meyer Instruments, Inc., 1304 Langham Creek, Suite 235, Houston, TX 77084.



FIG. 3 Photograph of Acid Delivery System

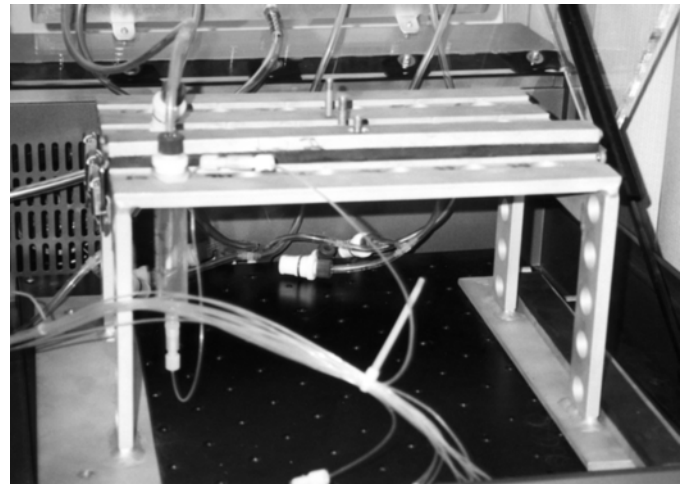

FIG. 6 Photograph of Test Tube Assembly Rack

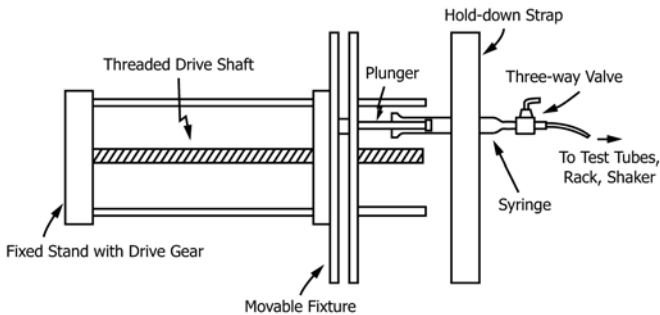

FIG. 4 Schematic of Acid Delivery System

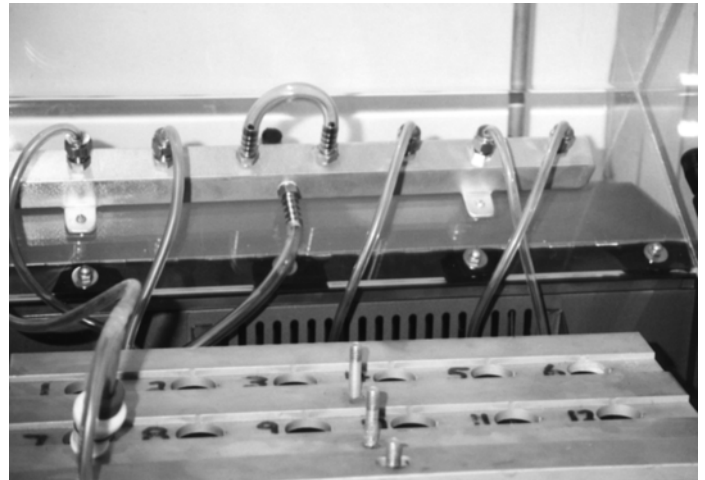

FIG. 7 Gassing Manifold for Venting

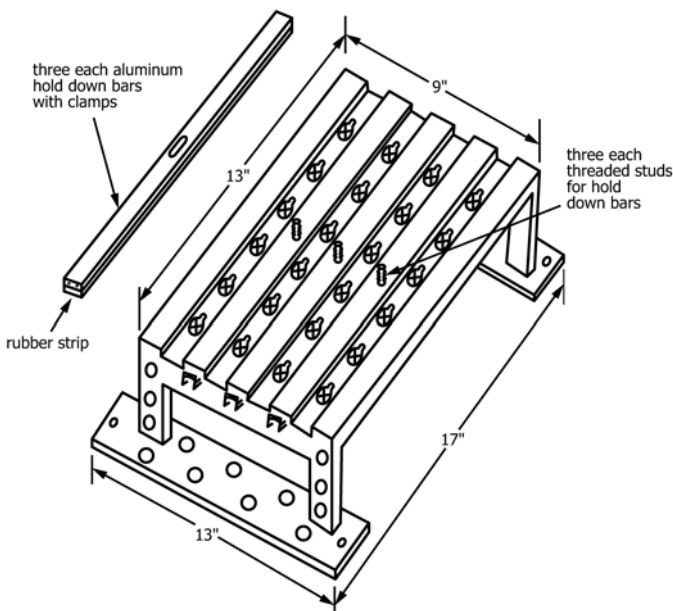

FIG. 5 Test Tube Assembly Rack

- 6.8.1.19 Power cords, and
- 6.8.1.20 Ultracentrifuge tube spacer with a 5 mm hole drilled in the center (used as a sample holder and sample randomizer for sample orientation).

6.8.2 *Image Capture Hardware and Software:*

- 6.8.2.1 Research grade, high resolution, NTSC RGB/RS-170 camera system,
- 6.8.2.2 Research grade, high resolution, NTSC RGB/RS-170 frame grabber,
- 6.8.2.3 The host computer system (shall meet or exceed the following specifications):

(1) *Hardware*—Pentium 133 MHz CPU, 16 MB RAM, 540 MB hard drive, 1.44 MB 90 mm floppy, 1.44 MB 130 mm floppy (optional), CD-ROM (highly recommended option), 101 or Windows 95 keyboard, SVGA local bus video card with 2 MB RAM (4 MB recommended), 2 button serial mouse with pad, 2 parallel ports, and 2 serial ports.

(2) *Software*—Windows 3.x/DOS 6.22 or Windows 95 Operating System, Microsoft Excel 7.0 (Microsoft Office 97 recommended).

(3) *Monitor*—Medical grade high-resolution 485 mm NTSC RGB color video monitor, all necessary cables, connectors, and adapters (including a surge and spike suppressing power strip).

6.8.3 *BRT Image Analysis Software:*

- 6.8.3.1 BRT macro program, and

6.8.3.2 Optimate image analysis engine.

7. Reagents and Materials

7.1 Reagents:

7.1.1 *Acid Solution* (**Warning**—Corrosive. Combustible. Health hazard)—Obtain the acid solution from the CPD.

NOTE 1—For information only. **Appendix X1** contains details of the acid solution.

7.1.2 *Acetone, 99.5 %*. (**Warning**—Flammable. Health hazard.)

7.1.3 *n-Heptane, (38 to 42) % (purity), commercial grade, with C₇ isomers*. (**Warning**—Flammable. Health hazard.)

7.2 Materials:

7.2.1 *TFE-fluorocarbon FEP Tubing*, inside diameter (I.D.) 0.8 mm, outside diameter (O.D.) 1.6 mm, 17 rolls, each roll 305 m. (Not required if the optional NRS flow controller^{7,11} is used.)

7.2.2 *Vinyl Tubing*, about 4.6 m in length with an (I.D.) 3.2 mm and an (O.D.) 6.4 mm.

7.2.3 *Miscellaneous Common Laboratory Equipment*, including glassware, tubing fittings, trays, vials, and plastic syringes.

8. Preparation of Apparatus

8.1 Specimens:

8.1.1 Remove the appropriate number of specimens from vacuum-sealed packages into a 118 mL bottle (clear, medium-round with cap). Add sufficient heptane (see 7.1.3), approximately 59 mL, to cover specimens.

8.1.2 Cap the bottle loosely and place it in an ultrasonic cleaning bath. Sonicate for 30 min, and then decant the heptane.

8.1.3 Rinse two more times with heptane and follow with an acetone (see 7.1.2) rinse to ensure the specimens are free of contamination. Dry the specimens with nitrogen for (30 to 60) s.

NOTE 2—The specimens can be prepared up to one week in advance and stored in heptane until needed for testing.

8.2 Test Tube Assembly, Tube Rack, and Shaker for Each Test Tube:

8.2.1 Cut 24 separate pieces of TFE-fluorocarbon FEP tubing, each piece to be 240 mm long.

8.2.1.1 Use compressed air (for technical use only), 345 kPa minimum, to remove most of the water/oil emulsion that can be trapped inside the short lengths of capillary tubing. Clean the tubing with heptane (see 7.1.3), followed by acetone (see 7.1.2), and dry with compressed air.

8.2.2 Check the flangeless fitting for the TFE-fluorocarbon tubing (O.D. 1.6 mm) for deterioration, and replace as necessary.

8.2.3 Remove and discard the plunger from a new 20 mL disposable plastic syringe (Luer-Lok), and securely fasten the

syringe barrel to the short capillary tubing, using couplings, ¼-28 thread, and female Luer CTFE fittings, ¼-28 thread, and with a 1.5 mm bore.

8.2.3.1 Label the syringes (test tubes) from 1 to 24.

8.2.4 Place the assembled test tube in the tube rack with the capillary tubing facing upward in the adjacent small hole.

8.2.4.1 The test tube assembly rack is a specially designed aluminum fabrication. It holds 24 test tubes with easy snap-on lock, wing nuts, and hold-down bars (see Fig. 5).

8.2.5 Place one precleaned specimen into each test tube, using forceps that are 180 mm long, and have serrated tips to avoid contamination.

8.2.6 Insert 10 mL of test oil into each test tube, using a disposable syringe with a capacity of 10 mL.

8.2.7 Secure the test tubes to the tube holder with three hold-down bars and three wing nuts.

8.2.8 Fasten the test tube assembly rack to the shaker platform with four custom-made wing bolts.

8.3 Acid Delivery System:

8.3.1 Withdraw 6 mL of acid solution by hand from a wide-mouth beaker into an individual disposable plastic syringe (Luer-Lok) with a capacity of 5 mL.

8.3.1.1 Attach the syringe to an acid inlet port of one of the 24 three-way switching valves, with ¼-28 thread. (The other two ports are used for air inlet and mixed air/acid outlet.)

8.3.2 Turn the three-way valve to *two-way open* and eject, by hand, about 0.5 mL of acid solution into a waste beaker, while ensuring that no air bubbles remain in the syringe.

8.3.2.1 Place the syringe that now contains about 5.5 mL of acid solution on the holder of the multiple syringes pump.

8.3.3 Repeat the above procedure for the other 23 acid delivery syringes.

8.3.4 There are three multiple syringe pumps, and eight of the 5 mL syringes are attached to each of the pumps.

8.3.4.1 The pumps each have a ten-position rack and are required to satisfy a minimum flow rate range of 0.0001 µL/h to 220.82 mL/min. Required accuracy is ±1 %, and reproducibility is ±0.1 %.

8.3.5 Ensure that the syringe barrel flange and the plunger flange are firmly held by the six retaining clamps, which are 51 mm C-clamps that secure the ends of the hold-down bars of the multiple syringes pump.

8.3.5.1 Good alignment of all 24 acid delivery syringes against the retaining brackets is crucial to ensure repeatability. (See Fig. 3 for a photograph of the acid delivery system, and Fig. 4 for a schematic.)

8.3.6 Cut 24 pieces of TFE-fluorocarbon tubing; each piece to be (1295 ± 25.4) mm in length.

8.3.6.1 Attach each of these tubes to the mixed air/acid outlet ports of the three-way switching valves.

8.4 Air Delivery System:

8.4.1 Clean, dry air, compressed to at least 345 kPa, is required.

8.4.2 A single stage, high-purity stainless steel pressure regulator is the first in the line; this is equipped with a (0 to 1100) kPa maximum pressure gauge.

8.4.3 Two compressed air filters capable of removing particles and mists are required, and are next in the line.

¹¹ Brooks Model 8744 NRS Flow Controller has been determined to be acceptable for this application. The sole source of supply of the apparatus known to the committee at this time is McPac Process Automation and Control, 8040 Bavaria Rd., Twinsburg, OH 44087.

8.4.3.1 The first filter in the line is an A912-DX type, followed by an A912-BX type. These have polycarbonate bowls and should be equipped with aluminum shields. They have ¼-in. NPT (F) ports and will withstand 1034 kPa pressure maximum.

NOTE 3—Alternatively, zero grade air cylinders can be used and will not require the extensive filtering outlined above.

8.4.4 A Drierite gas purifier, with a maximum working pressure of 690 kPa, is next in the line.

8.4.4.1 The first portion of the purifier (about 75 %) contains a molecular sieve, activated, Type 4A, 8 to 12 mesh.

8.4.4.2 The remaining portion of the purifier (about 25 %) contains Drierite absorbent, color indicating type, 8 mesh.

8.4.5 Next in the line is the downstream regulator, single stage high-purity stainless steel, that is equipped with a (0 to 415) kPa pressure gauge.

8.4.6 The next installation is a relief valve, in-line adjustable CA series, (345 to 1035) kPa cracking pressure range, set at 550 kPa (optional to control over pressure).

8.4.7 Lastly, install an air delivery manifold with 25 port outlets and 6.4 mm tube fittings. (See Figs. 1 and 2 for a photograph and schematic of the air system.)

8.4.8 Cut 25 pieces of the TFE-fluorocarbon tubing, each piece to be approximately 183 m in length.

8.4.8.1 These long tubes provide the necessary backpressure to allow good control of the very low airflow rate. The individual lengths may need to be adjusted slightly to ensure the same flow rates at a given delivery pressure. An equivalent multiport flow control system can be used.^{7,11}

8.4.8.2 Connect these tubes to the air delivery manifold.

(1) Connect one of these tubes to a calibrated flowmeter, capable of measuring up to 200 mL/min, and with a resolution of 0.1 mL/min (see Annex A1).

(2) Connect the other 24 tubes to the air inlet ports on the 24 three-way valves.

9. Procedure

9.1 Turn the three-way valve to *two-way open*, activate the syringe pumps, and eject 1 mL of acid solution into a waste beaker at a speed of 0.1 mL/min.

9.1.1 Make sure that the retaining brackets properly align all 24 syringe plungers.

9.2 Adjust the acid solution flow rate to 0.193 mL/h (test flow rate), and run for 1 h to ensure that all syringe plungers are properly aligned at the retaining brackets of the pusher block.

9.3 Set the actual air flow rate to 40 mL/min.

9.3.1 Monitor the airflow rate with the calibrated flow meter connected to the reference air capillary tubing. Refer to the calibration chart developed in Annex A1 to determine the actual air flow rate setting.

9.4 Turn the three-way valves to the *three-way open* position, and dry the nominal 1295 mm lengths of capillary tubing with air for 30 min.

9.5 Measure and record the airflow rates of all lines, and then shut off the main airflow valve.

9.6 Connect the long capillary tubing (that is, the nominal lengths of 1295 mm) to the short capillary tubing from the test tubes.

9.7 Connect all 24 stopper vent lines to the top of the test tubes.

9.7.1 TFE-fluorocarbon thermometer adapters are used as stoppers, 1½ joint.

9.7.2 Attach the vent lines to barbed tee connectors (clear polypropylene tubing, with an I.D. of 3.2 mm).

9.7.3 Then, connect the vent outlets to a gas venting manifold (8 port inlet with hose barbs, size 6.4 mm; use vinyl tubing with an I.D. of 3.2 mm by an O.D. of 6.4 mm (see Fig. 7)).

9.7.4 Finally, connect the gas venting manifold's outlet to a condensate trap flask (with a side arm) having a capacity of 1000 mL, placed such that gravity drains the condensate from the test tubes. *Make sure that all of the capillary tubes are free to move with the shaker platform.*

9.8 Set the shaker temperature to maintain $(48 \pm 0.1) ^\circ\text{C}$, as measured in an actual oil sample, and warm up the entire system to the control temperature in the oil sample for a period of 1 h. Refer to the calibration chart developed in Annex A2 to determine the shaker temperature setting.

9.9 Following the 1 h warm-up period, turn on the shaker, set the shaker speed to 300 r/min, and ensure that each ball freely rotates against each syringe wall.

9.10 Start introducing the acid solution at an actual flow rate of 0.193 mL/h. Refer to the calibration chart developed in Annex A3 to determine the actual flow rate setting.

9.11 Turn on the main airflow valve; check and adjust, if necessary, the upstream pressure (that is, upstream from the three-way valves) to ensure that the actual air flow rate is 40 mL/min.

9.12 Maintain the above test conditions for 18 h.

9.13 At the end of the test, stop the syringe pumps, shut off the airflow, and turn off the shaker.

9.14 Disconnect the acid/air delivery tubes from the test tube assembly, and remove the stoppers from the test tubes.

NOTE 4—The preceding procedure described the use of three multiple syringe pumps and 24 test tubes. However, as a minimum, one multiple syringe pump with a maximum of 10 test tubes can also be utilized.

10. Reference Oil Testing

10.1 Procure a supply of reference oils directly from the TMC.

10.1.1 These oils have been formulated or selected to represent specific chemistry types or performance levels, or both. Each reference oil is identified with a unique identification code on the container label.

10.2 Request a reference oil assignment from the TMC. Assignments are made by the unique identifying codes on the reference oil samples.

10.2.1 Provide the TMC with the shaker table identification for the test.

10.3 Test the assigned reference oil along with each batch of non-reference oil tests, simultaneously with and in the same shaker table as the non-reference oils.

10.3.1 Run the reference oil test in accordance with the same procedure used for the non-reference oil tests.

10.3.2 Inclusion of this coded (that is, blind) reference oil helps protect against the possibility of bias in the testing.

NOTE 5—Annex A4 discusses the involvement of the TMC with respect to the reference oil-monitoring program.

10.4 The testing laboratory tacitly agrees to use the reference oils in accordance with Policies for Use and Analysis of ASTM Reference Oils,² and to run and report the reference oil test results in accordance with TMC guidelines.

10.5 Report the reference oil test results to the TMC in accordance with the following guidelines:

10.5.1 Use the data reporting formats detailed in Annex A5 (see Figs. A5.1 through A5.4) for reporting all reference oil test results to the TMC.

10.5.2 Do not include any non-reference oil test results.

10.5.3 Complete all of the required blank fields on the forms.

10.5.4 Transmit reference oil test data by electronic means or by telephone facsimile to the TMC immediately upon completion of the test analysis.

10.5.4.1 Include all of the reporting forms in the transmission.

NOTE 6—Specific protocols for the electronic transmission of test data are available from the TMC.

10.6 Upon receipt of the initial reference oil test results, the TMC reviews the data for operational adherence to the published procedure.

10.6.1 If the test is determined to be operationally valid, the test results are then evaluated, using statistical acceptance criteria established by the governing surveillance panel.

10.6.1.1 The acceptance criteria are subject to change at the discretion of the surveillance panel.

10.6.2 If the initial transmitted data is determined to be both operationally valid and statistically acceptable, the TMC notifies the testing laboratory of that finding.

10.6.2.1 The TMC also discloses the uncoded reference oil identification to the testing laboratory.

10.7 In the event that a reference test is determined unacceptable by the TMC, the TMC provides an explanation to the testing laboratory.

10.7.1 If there is an obvious operational problem for the unacceptable test results, the problem has to be corrected before requesting another reference oil assignment from the TMC.

10.7.2 If the reason for the unacceptable results is not obvious, recheck all test-related equipment for compliance with the procedure and good laboratory practice.

10.7.3 Following this rechecking process, the TMC assigns another coded reference oil for testing.

10.8 The non-reference oil tests are considered valid only if the results of the accompanying reference oil test meet the predetermined acceptance criteria for the particular reference oil tested.

11. Test Results

11.1 Prepare Specimens for Image Analysis:

11.1.1 Remove the specimens from the test tubes, using forceps that are 180 mm long, with serrated tips).

11.1.2 Place each specimen into a separate scintillation wash vial (make one perforation in the bottom to facilitate cleaning), with a capacity of 20 mL, and then into a vial holder.

11.1.3 Put the vial holder into a utility tray (stainless steel, 310 mm by 200 mm by 60 mm), pour enough heptane into the tray to cover the specimens, and shake the tray gently for (30 to 60) s before decanting the heptane.

11.1.4 Put enough heptane (see 7.1.3) into the tray to cover the specimens, and soak the specimens for 10 min to remove any remaining organic deposits, before decanting the solvent.

11.1.5 Put enough heptane into the tray to cover the specimens, and shake the tray gently for (30 to 60) s before decanting the heptane.

11.1.6 Transfer the specimens into clean, dry scintillation vials of 20 mL capacity that have been previously labeled the same as the test tubes in 8.2.3.1.

11.1.7 Dry the specimens with nitrogen gas, and then securely fasten the vial caps.

11.2 Prepare Image Analysis System for Rust Evaluation:

11.2.1 Set the microscope adjustments as follows:

11.2.1.1 Illumination change-over knob B/D—D (dark field).

11.2.1.2 ND16 filter slider—IN (push to first click).

11.2.1.3 A filter slider—IN (push to second click).

11.2.1.4 F (field diaphragm control lever)—OPEN.

11.2.1.5 A (aperture diaphragm control lever)—OPEN.

11.2.1.6 Neutral density filter—ND16.

11.2.1.7 Objective lens—5×.

11.3 Optronics Controller:

11.3.1 Shutter speed— $\frac{1}{60}$ + (manual).

11.3.2 White balance—ON.

11.4 Turn on the Image Analysis Computer and initiate the *Optimate* software program.

11.5 Select the macro titled *BRT51.MAC* (BRT Macro Version 5.1, or later).

11.6 Rust Rating Procedure:

11.6.1 Wipe each specimen, using a lint-free laboratory wipe; remove all solvent film and loose surface deposits from the rating surfaces prior to the digital image rating.

11.6.2 Place the Calibration Reference Specimen onto the microscope stage, and follow the dialog box instructions that appear on the screen (operator interface) (see Fig. 8).

NOTE 7—Refer to the software manual for the detailed procedure of imaging analysis.

11.6.2.1 Answer the operator interface questions to allow automatic recording of the data into the spreadsheet program.

11.6.3 Rotate (without skin contact) the Calibration Reference Specimen, and take 20 different readings.

11.6.3.1 The average gray value for the Calibration Reference Specimen at the start of the image analysis shall be

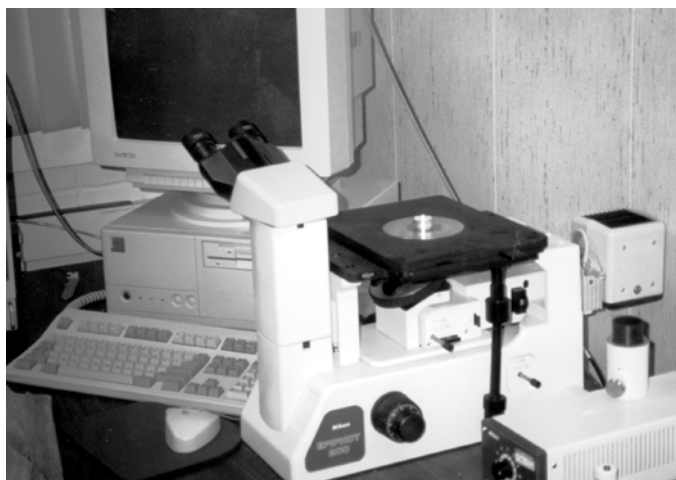

FIG. 8 Microscope, Stage, and Computer

135 ± 2. The average gray values for the Calibration Reference Specimen at the start and end of the image analysis shall not differ by more than 3.

11.6.4 Repeat the previous step for each specimen. (The Calibration Reference Specimen is the first and last specimen analyzed to ensure no drift has occurred during analysis.)

12. Precision and Bias

12.1 Precision:¹²

12.1.1 *Intermediate Precision* (formerly called *repeatability*)—The difference between two results obtained with the same oil, using the same test method, in the same laboratory, using the same apparatus (different test tubes), would, in the normal and the correct operation of the test method, exceed the following value in only one case in twenty:
15.15 AGV

12.1.2 *Reproducibility*—The difference between two single and independent test results obtained with the same oil in different laboratories would, in the normal and the correct operation of the test method, exceed the following value in only one case in twenty:
18.89 AGV

12.2 *Bias*—No bias is believed to exist. However, this aspect of the test will be reevaluated after the test method has been in use by several laboratories over an appropriate period of time.

13. Keywords

13.1 Ball Rust Test; corrosion; engine oil; rust

¹² Supporting data have been filed at ASTM International Headquarters and may be obtained by requesting Research Report RR:D02-1483.

ANNEXES

(Mandatory Information)

A1. DIGITAL AIR FLOWMETER CALIBRATION

A1.1 Connect the reference air line to the digital gas flowmeter inlet port, and attach capillary tubing from the flowmeter outlet to a calibrated bubble meter.

A1.2 Calculate the actual air flow rate for the digital flowmeter by using the following formula:

$$\text{air flow rate (mL/min)} = \frac{100 \text{ mL}}{\text{time (min)}} \quad (\text{A1.1})$$

A1.3 Repeat A1.2 for digital indicator readings of (35.0, 40.0, 45.0, 50.0) mL/min.

A1.4 Plot the calibration curve of digital airflow set point versus actual airflow rate to provide an airflow correction chart.

A1.5 *Alternatively*, connect the reference air line to the digital gas flowmeter inlet port, and attach capillary tubing from the flowmeter outlet to a large open beaker of 1 L (or larger) size, partially filled with water.

A1.6 Fill a 100 mL volumetric cylinder with deionized water, and secure the cylinder in an inverted position to a stand. Make sure the cylinder is perpendicular to the water level.

A1.6.1 Attach capillary tubing from the top of the cylinder, and place the tubing outlet into the partially filled beaker.

A1.7 Adjust the pressure gauge valve to set the digital indicator at 30.0 mL/min. Allow 5 min to ensure that the airflow has stabilized.

A1.8 Remove the capillary air line from the beaker, and attach it to the bottom valve of the inverted volumetric cylinder.

A1.9 Measure the minutes required to displace 100 mL of water from the cylinder.

A1.10 Record the set pressure, digital air flowmeter reading, and displacement time.

A1.11 Repeat directions provided in A1.2 – A1.4 to calculate the actual airflow rate for the digital flowmeter.

A2. SHAKER TEMPERATURE CALIBRATION

A2.1 Insert a representative oil sample of 10 mL into a plastic syringe with a capacity of 20 mL, as part of a test tube assembly, and place the assembly in the test tube rack at rack location No. 10 (second row from the gas venting manifold and fourth slot from the left).

A2.2 Immerse a calibrated digital thermometer into the oil sample without blocking the air inlet port that is left open.

A2.3 Introduce 40 cm³/min of air to circulate the oil.

A2.4 Adjust the shaker temperature control to 40 °C. Record the actual temperature from the calibrated digital thermometer every 30 min for 4 h.

A2.5 Repeat **A2.2 – A2.4** for shaker temperature set points of 50 °C and 60 °C.

A2.6 Plot the calibration curve of shaker set point temperature versus actual temperature to provide a temperature control correction chart.

A3. MULTIPLE SYRINGE PUMP LIQUID FLOW CALIBRATION

A3.1 Determine the density of the acid solution, in grams per millilitre. It is convenient to weigh the 1 L of solution after it has been prepared. Use a calibrated balance to obtain the mass of the 1 L of solution, and subtract the mass of the empty flask to obtain the actual mass of the solution. (Or, use a calibrated density meter.)

A3.2 Weigh 24 of the scintillation vials (labeled 1 to 24) of 20 mL capacity individually on a calibrated balance.

A3.3 Withdraw 6 mL of acid solution from a wide-mouth beaker into each of the twenty-four 5 mL plastic syringes by hand, and attach the syringes to the acid inlet ports of the three-way valves.

A3.3.1 Turn the three-way valves to the *two-way open* position, and withdraw by hand about 0.5 mL of solution from each syringe into a waste beaker while ensuring that no air bubbles remain in the syringes.

A3.4 Place the individual syringes, which now contain 5.5 mL of solution, on the holder of the multiple syringe pumps (consists of three separate pumps with eight syringes operated by each pump).

A3.4.1 Press the retaining brackets firmly against the syringe barrel flange and the plunger flange and tighten the retaining screws. *A good alignment of all 24 syringes against the retaining brackets is crucial for good calibration.*

A3.5 Activate the multiple syringe pumps and withdraw 1 mL of solution from each of the 24 plastic syringes into a waste beaker for 2 min at 0.5 mL/min. During this pump operation of 2 min, make sure that all 24 syringe plungers are well seated in the retaining brackets.

A3.6 Reduce the pump speed to 0.150 mL/h, and operate for 1 h. Ensure that all syringe plungers are properly aligned at the retaining brackets of the pusher block.

A3.6.1 Stop the pump, and ensure that no air bubbles remain in the capillary lines.

A3.7 Place filled capillary lines into corresponding 20 mL vials.

A3.7.1 Seal the vial opening with parafilm to avoid any evaporation of the acid solution during the calibration.

A3.8 Start the pump, and also start a calibrated clock for 18 h.

A3.8.1 At the end of 18 h, stop the pump and remove the parafilm and capillary lines.

A3.9 Reweigh the vials, and calculate the mass gain for each vial. Total the mass gains for each bank of the appropriate eight vials to obtain the mass gain for an individual pump.

A3.10 Calculate the actual pump flow rate for the individual three pumps by using the following formula:

$$\text{flow rate (mL/h)} = \frac{\text{mass gain (g)}}{\text{density (g/mL)} \times \text{time (h)}} \quad (\text{A3.1})$$

A3.11 Repeat **A3.3 – A3.10** for pump flow rate set points of (0.20 and 0.25) mL/h.

A3.12 For each pump, plot the calibration curve of set flow rate versus actual flow rate to provide a pump flow correction chart.

A4. THE ROLE OF THE ASTM TEST MONITORING CENTER (TMC)

A4.1 The TMC is a nonprofit organization located in Pittsburgh, PA.

A4.2 *Operation*—The TMC operates in accordance with the Rules and Regulations Governing the ASTM Test Monitoring System, which was developed and approved by Subcommittee D02.B0, and subsequently, approved by Committee D02.

A4.3 *Management*—The management of the ASTM Test Monitoring System is vested in the Test Monitoring Board (TMB) elected by Subcommittee D02.B0. The TMB, in turn, selects the TMC Administrator who is responsible for directing the activities at the TMC.

A4.4 *Duties*—The TMC is staffed to administer technical studies, conduct laboratory visits, perform statistical analyses of reference oil test data, provide reference oils to test laboratories, and maintain the calibration programs for various test methods as directed by the TMB.

A4.5 *Coordination*—The TMC coordinates its activities among the test sponsors, test developers, surveillance panels, and testing laboratories.

A4.6 *Income*—The TMC’s operating income is obtained from fees levied on the reference oils supplied to the test laboratories and on the calibration tests conducted.

A4.7 *Laboratory Participation*—For those laboratories choosing to utilize the services of the TMC in maintaining the calibration of a monitored ASTM test method, calibration testing is required at regular intervals as determined by the responsible surveillance panel.

A4.7.1 These calibration tests are conducted using coded reference oils as outlined in Section 10 of this test method.

A4.7.2 It is the laboratories’ responsibility to maintain the calibration of the test method, and to keep on-site reference oil inventory at or above the minimum level specified by the TMC.

A4.8 *New Laboratories*—New laboratories desiring to participate in the ASTM Test Monitoring System should contact the TMC Administrator. Information concerning fees, laboratory inspections, testing practices, appropriate surveillance panel membership, and rater training will be provided.

A4.8.1 Initially, a new laboratory will be requested to conduct reference oil tests to ensure that the laboratory is using the proper testing techniques.

A4.9 *New Reference Oils*—When new reference oils are introduced, participating laboratories will be requested to run and donate the tests necessary to develop performance targets and precision, and performance acceptance limits.

A4.9.1 The appropriate surveillance panel with TMC input will design the test program for prospective new reference oils.

A4.10 *Information Letters*—Occasionally, it might become necessary to change a test method, and notify participating laboratories of the change, prior to approval of the change by Subcommittee D02.B0. In such a case, the TMC issues an Information Letter.

A4.10.1 Normally, prior to each Subcommittee D02.B0 meeting held in conjunction with the semiannual Committee D02 meeting, the accumulated information letters are balloted by Subcommittee D02.B0.

A4.10.2 Subsequently, test methods that are affected by changes in Information Letters are revised accordingly, balloted in Committee D02, and finally approved by ASTM.

A4.10.3 By these actions, ASTM due process procedures are applied to the TMC Information Letters.

A4.10.4 The ASTM Committee on Technical Committee Operations (COTCO) in 1984 gave authority for the issuance of information letters, as follows: “COTCO recognizes that D02 has a unique and complex situation. The use of Information Letters is approved providing each letter contains a disclaimer to the effect that such has not obtained ASTM consensus. These Information Letters should be moved to such consensus as rapidly as possible.”

A4.10.5 Information letters issued subsequent to the issue date of this test method update the test method and should be obtained from the TMC.

A4.11 *Memoranda*—The TMC might also issue memoranda to convey information, such as clarification of the test procedure and approval for alternative test parts or materials or for any other matters having no affect on test performance, results, precision, and bias.

A5. BALL RUST TEST REPORT FORMS AND DATA DICTIONARY

A5.1 Download report forms and data dictionary from the ASTM Test Monitoring Center (TMC) web page at: <http://www.astmtmc.cmu.edu/>. The TMC can also provide hard copies upon request.

Report Form Table of Contents

1. Final Report Cover Sheet
2. Summary of Results
3. Comments

APPENDIX

(Nonmandatory Information)

X1. PREPARATION OF ACID SOLUTION

X1.1 *Acid Solution Preparation* (Example: 1 L of solution):

X1.1.1 Using a three-place balance, accurately weigh each of the chemicals listed in **Table X1.1**. Use separate clean, dry beakers of 50 mL capacity for three of the chemicals, and a beaker of 100 mL capacity for HCl. Flush and rinse a 1 L flask with a small amount of deionized water, and empty the individual beakers into the flask. Fill the 1 L flask with deionized water up to the 1 L mark.

X1.1.2 Put a magnetic stir bar into the 1 L flask, put a stopper in the flask, and place the flask on a stirring plate.

TABLE X1.1 Acid Solution

Component	Amount
	(ensure accuracy within 0.2 %)
Acetic acid	6.646 g
HBr	4.892 g
HCl	103.232 g
Deionized water	Fill to 1 L mark

Adjust to a moderate stirring speed, and allow stirring at room temperature for 30 min. Remove the stir bar from the flask.

SUMMARY OF CHANGES

Subcommittee D02.B0.01 has identified the location of selected changes to this standard since the last issue (D6557 – 10a) that may impact the use of this standard.

(1) Editorial changes were made, applying Form and Style (including SI 10) guidelines.

ASTM International takes no position respecting the validity of any patent rights asserted in connection with any item mentioned in this standard. Users of this standard are expressly advised that determination of the validity of any such patent rights, and the risk of infringement of such rights, are entirely their own responsibility.

This standard is subject to revision at any time by the responsible technical committee and must be reviewed every five years and if not revised, either reapproved or withdrawn. Your comments are invited either for revision of this standard or for additional standards and should be addressed to ASTM International Headquarters. Your comments will receive careful consideration at a meeting of the responsible technical committee, which you may attend. If you feel that your comments have not received a fair hearing you should make your views known to the ASTM Committee on Standards, at the address shown below.

This standard is copyrighted by ASTM International, 100 Barr Harbor Drive, PO Box C700, West Conshohocken, PA 19428-2959, United States. Individual reprints (single or multiple copies) of this standard may be obtained by contacting ASTM at the above address or at 610-832-9585 (phone), 610-832-9555 (fax), or service@astm.org (e-mail); or through the ASTM website (www.astm.org). Permission rights to photocopy the standard may also be secured from the Copyright Clearance Center, 222 Rosewood Drive, Danvers, MA 01923, Tel: (978) 646-2600; <http://www.copyright.com/>