



# Standard Guide for Mechanical Attachment of Geomembrane to Penetrations or Structures<sup>1</sup>

This standard is issued under the fixed designation D6497/D6497M; the number immediately following the designation indicates the year of original adoption or, in the case of revision, the year of last revision. A number in parentheses indicates the year of last reapproval. A superscript epsilon ( $\epsilon$ ) indicates an editorial change since the last revision or reapproval.

<sup>ε1</sup> NOTE—Designation was changed to dual, units information was corrected and 2.1 was inserted editorially in June 2015.

## 1. Scope

1.1 This guide covers procedures that can be employed to mechanically attach fabricated geomembranes to structures, pipes, etc.

1.2 This guide does not address all problems or situations a geomembrane installer or design engineer may face in the attachment of geomembranes to structures, pipes, etc. The sole purpose of this standard guide is to point out typical problems with geomembrane attachments and clearly state objectives of each component of the geomembrane attachment(s).

1.3 This guide has been generated for geomembrane application(s); however, a geomembrane installer or design engineer, or both, may find portions of this guide applicable to other geosynthetics.

1.4 The values stated in either SI units or inch-pound units are to be regarded separately as standard. The values stated in each system may not be exact equivalents; therefore, each system shall be used independently of the other. Combining values from the two systems may result in non-conformance with the standard.

1.5 *This standard does not purport to address all of the safety concerns, if any, associated with its use. It is the responsibility of the user of this standard to establish appropriate safety and health practices and determine the applicability of regulatory limitations prior to use.*

## 2. Referenced Documents

### 2.1 ASTM Standards:<sup>2</sup>

**C717 Terminology of Building Seals and Sealants**

**C822 Terminology Relating to Concrete Pipe and Related Products**

<sup>1</sup> This guide is under the jurisdiction of ASTM Committee D35 on Geosynthetics and is the direct responsibility of Subcommittee D35.10 on Geomembranes.

Current edition approved May 1, 2015. Published June 2015. Originally approved in 1999. Last previous edition approved in 2010 as D6497–02(2010). DOI: 10.1520/D6497\_D6497M-02R15E01.

<sup>2</sup> For referenced ASTM standards, visit the ASTM website, www.astm.org, or contact ASTM Customer Service at service@astm.org. For *Annual Book of ASTM Standards* volume information, refer to the standard's Document Summary page on the ASTM website.

**D4439 Terminology for Geosynthetics**

**D4848 Terminology Related to Force, Deformation and Related Properties of Textiles**

**F118 Definitions of Terms Relating to Gaskets**

2.2 *EPA Document:*<sup>3</sup>

**Quality Assurance and Quality Control for Waste Containment Facilities, Technical Guidance Document, United States Environmental Protection Agency, EPA/600/R-93/182, September 1993**

## 3. Terminology

### 3.1 Definitions:

3.1.1 *banding strap, n*—a flexible narrow strip of metal, plastic or other material, which compresses the geomembrane around a penetration by acting as a clamp around the penetration.

3.1.2 *batten, n*—a rigid narrow strip of metal, wood, plastic or other material which distributes the forces to compress the geomembrane against a penetration or structure.

3.1.3 *boot, n*—a factory or field fabricated geomembrane wrap used to seal around a pipe penetration prior to attachment (see Fig. 1).

3.1.4 *clamp, n*—a flexible narrow strip of metal, plastic or other material, which compresses the geomembrane against a penetration by tightening the bolt(s) or screw(s) of the clamp (see Fig. 2).

3.1.5 *concrete, n*—a homogeneous mixture of portland cement, aggregates, and water which may contain admixtures. **(C822)**

3.1.6 *gaskets, n*—a material, which may be clamped between contact surfaces that acts as a static seal. Gaskets are cut, formed, or molded into the desired configuration. They may consist of any of the following construction: one or more plies of a sheet material; composites of dissimilar materials; and materials applied as a bead or other form to one or both mating faces prior to assembly. **(F118)**

<sup>3</sup> Available from U.S. Government Publishing Office, 732 N. Capitol St., NW, Washington, DC 20401-0001, http://www.gpo.gov.

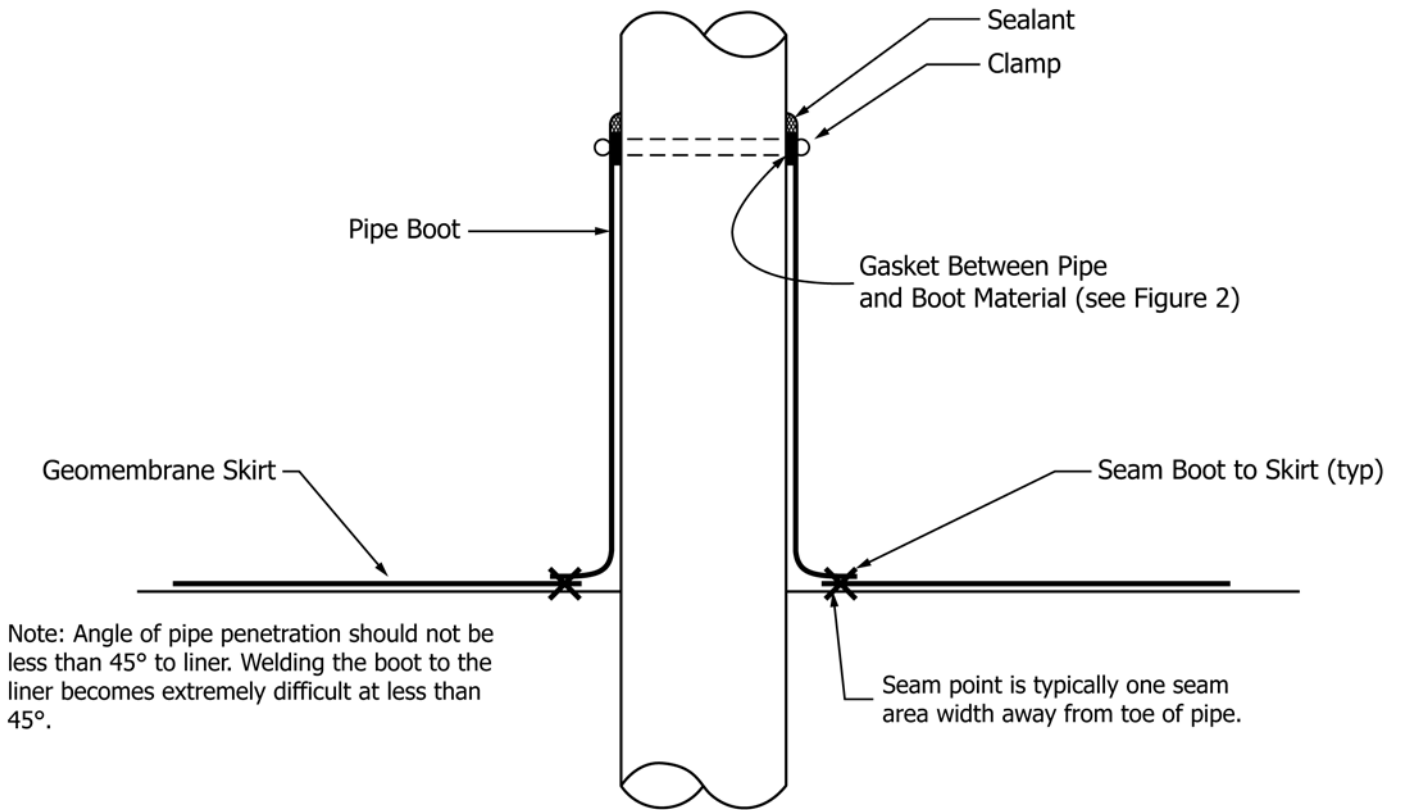

FIG. 1 Pipe Penetration—Perpendicular Face

3.1.7 *geomembrane, n*—an essentially impermeable geosynthetic composed of one or more synthetic sheets. (D4439)

3.1.8 *rondel, n*—a strip of polymeric material formed to a geometry, which is embedded and secured to a penetration or structure (for example, concrete structure) (see Fig. 3).

3.1.9 *sealant*—in building construction, a material that has the adhesive and cohesive properties to form a seal. (C717)

3.1.10 *torque, n*—a movement (of forces) which produces or tends to produce rotation or torsion. (D4848)

3.1.11 *void space, n*—in engineered structures, space(s) between the geomembrane and penetration or structure, which allow liquid or vapor migration, or allow the geomembrane to deform into the space(s) due to overburden pressure. (New, to be balloted under Terminology Committee.)

#### 4. Significance and Use

4.1 This guide attempts to detail specific areas of concern regarding the attachment of geomembranes to structures. Components of the geomembrane attachment are addressed as to the type and use of each component.

4.2 Although this guide does not address all aspects of geomembrane attachments, the user of this guide may note important objectives and design issues of each component of the geomembrane. All these objectives and design issues may or may not be required to obtain an appropriate geomembrane attachment. By describing these areas of concern, it is hoped that the user of this guide will be able to design geomembrane

attachments, develop specifications or construct geomembrane attachments, or both, which fulfill the requirements of its design intent.

#### 5. Types of Connection

5.1 *Batten(s)*—Battens are commonly used to attach a geomembrane to a smooth, flat surface. Anchor bolts are embedded into the penetration or structure at set locations. A gasket is placed in-line with the bolts to form a seal between the geomembrane and structure. Geomembrane is pushed or forced over the bolts to insure a tight fit and then placed against the penetration or structure. The batten, which has holes in it that are in alignment with the bolts, is placed over the geomembrane. Nuts are placed on the bolts and tightened with sufficient torque to compress the geomembrane against the penetration or structure. The geomembrane is held in place by the friction generated by the compression effect of the batten (see Fig. 4).

5.1.1 A compression sealant or gasket can be used between the geomembrane and the penetration or structure or batten, or both. The compression sealant or gasket will limit the migration of liquid or vapor through the batten connection.

5.2 *Clamp(s) or Banding Strap(s)*—Clamps or banding straps are commonly used to attach a geomembrane to a smooth, round penetration or structure (for example, pipe). The geomembrane is placed around the penetration or structure and welded as close as possible to the circumference of the

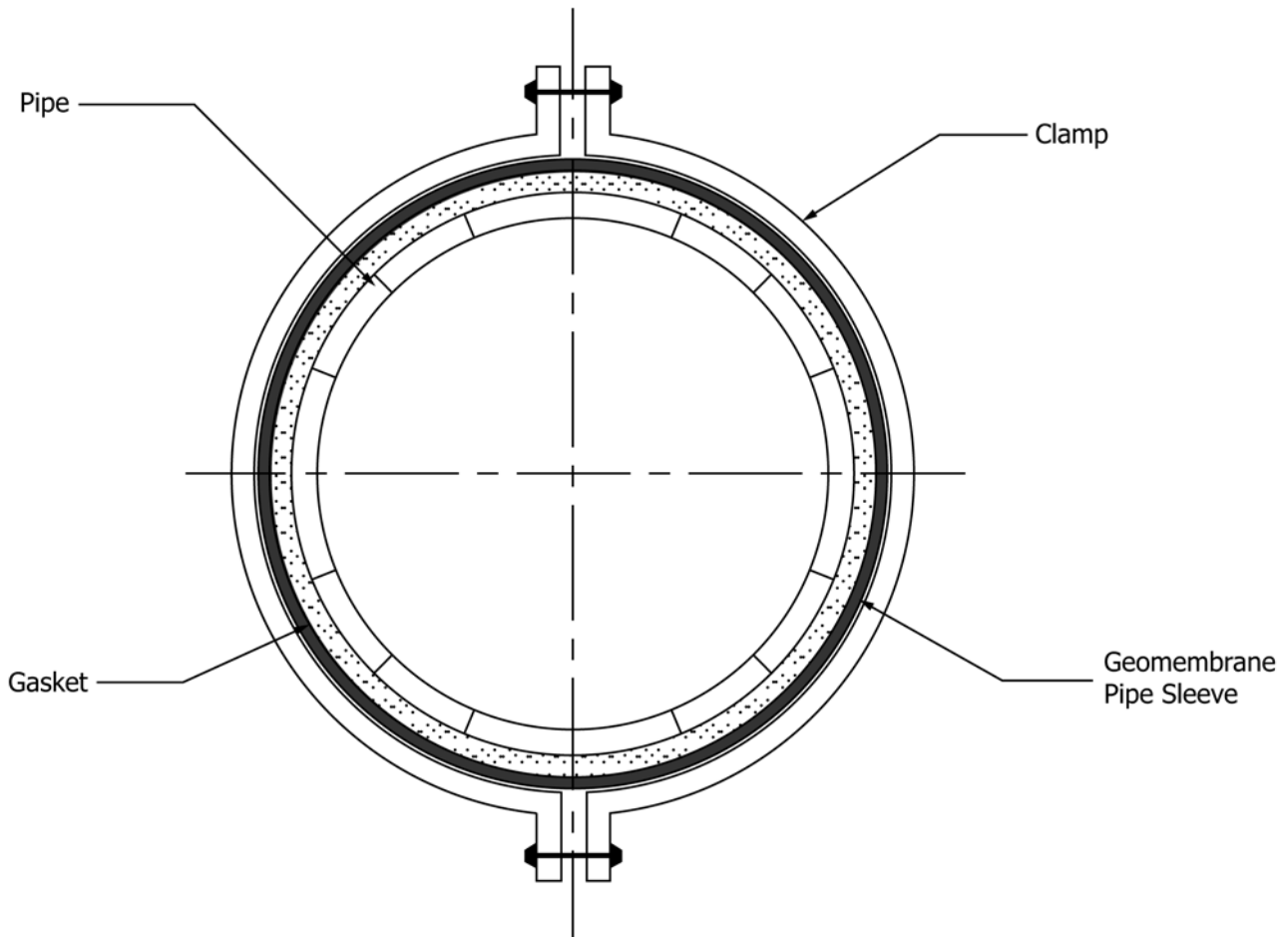

FIG. 2 Clamp Detail

penetration or structure. A gasket is placed around the penetration or structure at the location of the clamp placement to form a seal between the geomembrane and penetration or structure. The geomembrane is then put in-place and over the gasket. The clamp or banding strap is commonly tightened by applying a torque to a bolt or bolts, a screw or screws, or other mechanical device, which applies a pulling force that decreases the length of the clamp, or banding strap, thereby compressing the geomembrane and gasket to the penetration or structure. The geomembrane is held in place by the friction generated by tightening the clamp or banding strap and compressing the geomembrane against the penetration or structure.

5.2.1 A compression sealant or gasket can be used between the geomembrane and the penetration or structure or clamp, or both. The compression sealant or gasket will limit the migration of liquid or vapor through the clamp connection.

5.3 *Welded*—Welded connections can be either a solvent weld or heat weld. Heat welding of dissimilar materials can be accomplished as long as both materials are thermoplastic. It is recommended that welding criteria for dissimilar materials be reviewed with the material manufacturer before constructing the attachment.

5.3.1 The welded connections are commonly made to a rondel or pipe (see Fig. 5) composed of similar polymeric material as the geomembrane. The rondel is embedded into the

penetration or structure during its construction. For example, rondels are commonly embedded into a concrete structure. The material used for the penetration or structure is allowed to cure before attachment of the geomembrane. The curing time allows the rondel to become secured in the penetration or structure. Once the material used for the penetration or structure has cured sufficiently to reduce the risk of pulling the rondel from the penetration or structure, the geomembrane can be welded to the rondel (see Fig. 3).

5.3.2 Welding geomembranes to rondels and pipes is similar to welding geomembrane panels together. The geomembrane must be placed flush against the rondel or pipe during the welding process. The geomembrane and rondel or pipe must be clean or prepared, or both, according to the prescribed geomembrane manufacturer's procedure before welding.

5.3.3 Welding the geomembrane to the penetration or structure may provide an attachment that has a lower possibility of leakage. Since the geomembrane is attached directly to the structure, sealants are usually not required. However, special attention should be noted for rondels used for attachment of geomembranes to concrete structures. If several sections or pieces of rondels are required to construct an attachment, spaces or gaps between the individual sections or pieces could occur during their embedment and during the curing of the concrete. This would especially occur for rondels made of

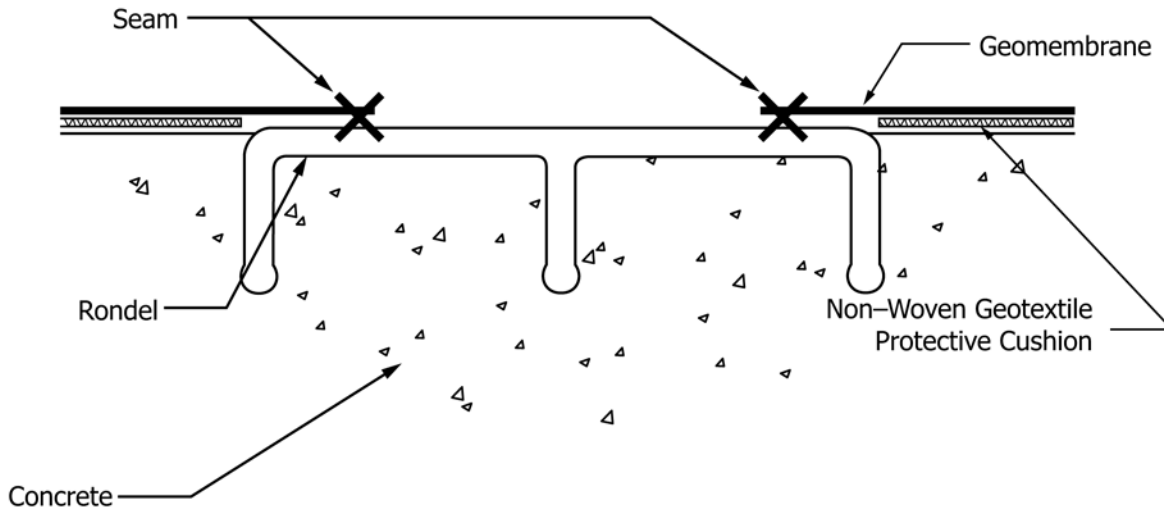

NOTE: RONDELS ARE MANUFACTURED IN VARIOUS SHAPES BY DIFFERENT MANUFACTURERS. CONTACT MANUFACTURER REGARDING DESIGN.

FIG. 3 Rondel Connection

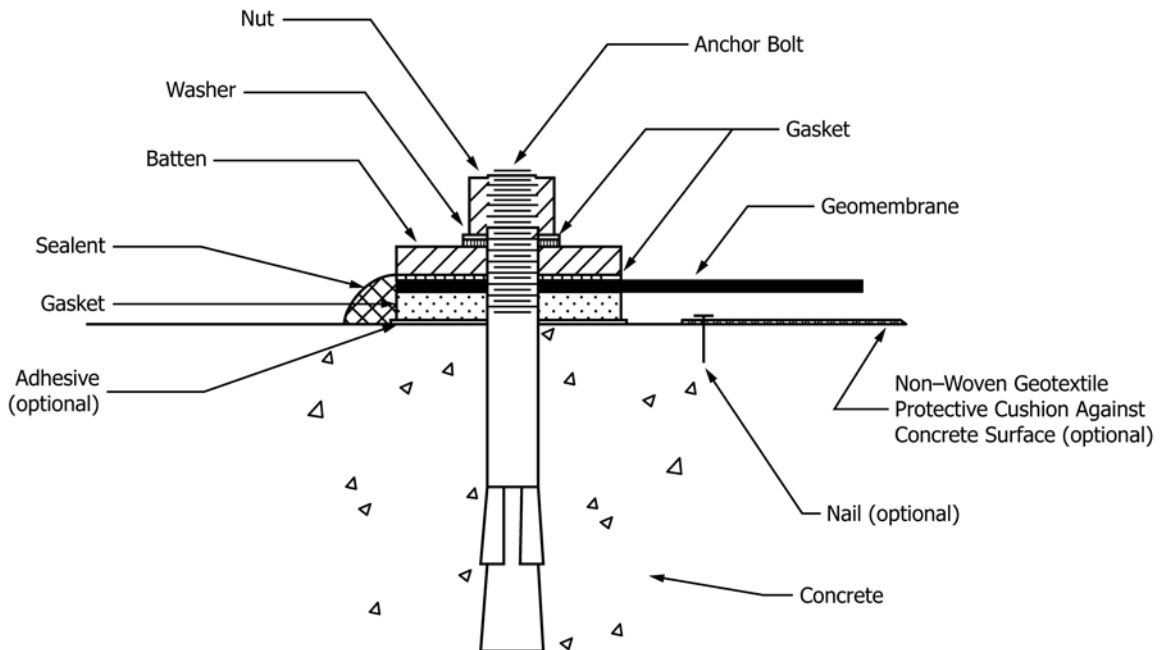

FIG. 4 Anchor Bolt Geomembrane Connection

polymeric material that expands and contracts according to the temperature of the concrete during the curing process. Sealants may be required to fill the spaces or gaps between the rondels to further limit the migration of liquid or vapor through the batten connection.

5.3.4 Pre-fabrication of the complete rondel attachment before placement into the concrete is recommended. The pre-fabricated rondel is composed of welded sections or pieces of rondels, thereby eliminating the possibility of gaps between sections or pieces on rondels after the concrete cures.

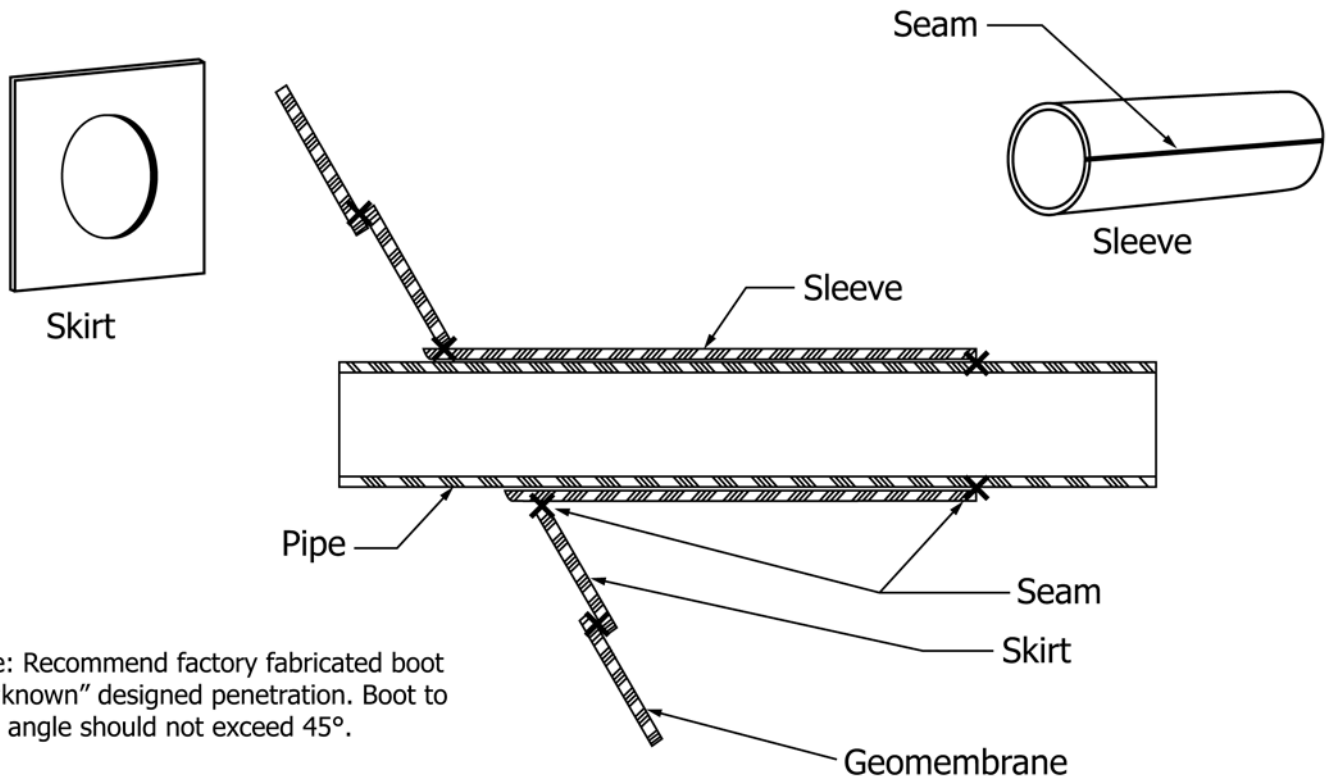

FIG. 5 Pipe Boot

5.4 *Bonded*—Bonded connections commonly require the use of an adhesive to construct the attachment. The use of an adhesive allows the geomembrane to be attached to dis-similar material. The adhesive used must be compatible with both the geomembrane and the surface material of the penetration or structure. The application and curing of the adhesive should not significantly deteriorate the strength of the geomembrane or the material surface of the penetration or structure beyond the design requirements of the attachment.

5.4.1 The geomembrane and the surface of the penetration or structure should be clean and prepared according to the adhesive manufacturer's and geomembrane manufacturer's recommendation.

5.4.2 Bonding the geomembrane to the penetration or structure may provide an attachment, which has a lower possibility of leakage. Since the geomembrane is attached directly to the structure, sealants are usually not required.

## 6. Types of Structures

6.1 *Concrete*—Concrete structures that require attachment of geomembranes include, but are not limited to, pads, floors, walls, tanks, manholes, and pylons. The use of battens, clamps or banding strips, or bonding can attach a geomembrane to concrete structures. When attaching a geomembrane to any concrete structure, consider each critical concern detailed in Section 7.

6.2 *Metal*—Metal structures that require attachment of geomembranes include, but are not limited to, pads, floors, walls, pipes, and tanks. The use of battens, clamps or banding strips, can attach a geomembrane to metal structures. When

attaching a geomembrane to any metal structure, consider each critical concern detailed in Section 7.

6.3 *Pipe*—Pipe structures can be composed of concrete, metal or polymer. Clamps, banding strips, solvent weld, or heat weld can attach a geomembrane to pipe structures. The attachment of a geomembrane to any pipe structure should consider critical concerns detailed in 7.1, 7.3, 7.4, 7.5, and 7.6.

## 7. Critical Areas for the Protection of the Geomembrane

7.1 *Surface Characteristics*—The surface of the structure for which the geomembrane is to be attached should be constructed or formed to limit damage to the geomembrane. This is particularly important in cases where the geomembrane will be pressed against the structure. Irregularities in the structure surface could cause stress points in the geomembrane, thereby, allowing portion(s) of the geomembrane to yield at a lower load than its design application. If a structure cannot be constructed or formed without irregularities, then a protective layer should be placed between the structure and the geomembrane (see Fig. 4).

7.2 *Edges of Structures*—Edges or corners of structures should be rounded to limit possible damage to the geomembrane. A protective layer can be constructed or placed over the edge or corner to protect the geomembrane.

7.3 *Large Voids Under Geomembrane*—Large voids under the geomembrane can cause deformation and stress in the geomembrane and geomembrane seams if, under pressure or load, the geomembrane is forced into the void(s). Large voids

should be filled or bridged to stop the geomembrane and geomembrane seams from becoming overly stressed (see Figs. 6 and 7).

**7.4 Settlement Around Structures**—If a geomembrane is to be connected to a structure and placed over an area which may settle at a greater or lesser rate than the structure, the design engineer or geomembrane installer should take precautions to limit settlement around the structure. If settlement around the structure cannot be avoided, then the design engineer should design a flexible connection to the structure that considers settlement and alleviates the stresses, which could occur due to settlement.

**7.5 In-Plane Attachment**—The geomembrane should be placed in parallel or “in-plane” with the structure or penetration to be attached. The geomembrane should lie flat against the surface of the structure or penetration for a sufficient distance prior to the geomembrane being placed “out of plane” of the structure or penetration. This is to avoid bridging within attachment, pulling away from the structure, or stresses within the geomembrane during the placement of the batten or clamp, or both. The attached figures show the geomembrane being parallel or “in-plane” to the structure or penetration as part of the attachment.

**7.6 Protection from Bolts, Battens, Clamps**—The installation of geomembrane over bolts, battens or clamps should be done with a protective layer placed between the geomembrane and these items to prevent damage to the geomembrane by these items (see Fig. 8).

**7.7 Cushion/Sealant Between Geomembrane and Structure, Geomembrane and Battens, Geomembrane and Clamps/Bands**—A cushion/sealant should be placed between the geomembrane and the structure, between the geomembrane and the batten or geomembrane and the clamps/band to protect

the geomembrane and allow for a seal between the geomembrane and the structure, batten, or clamp/band.

**8. Critical Items for Strength of Attachment**

**8.1 Cleanliness**—The area of the attachment should be cleaned to remove loose debris, dirt, oils, or other foreign material(s), or all of these, that could hinder the ability to develop a strong attachment of the geomembrane to the structure. It is recommended that the only materials in the area of the attachment should be the clean geomembrane, structure, and type of connection used to perform the attachment.

**8.2 Type of Attachment:**

**8.2.1 Battens:**

**8.2.1.1 Type of Batten Material**—Battens can be made of wood, metal, or polymer. The batten must remain functional for the design life of the attachment and be chemically resistant with the fluids or vapors to which it will be exposed. The batten should also be made of a material that will not crack, fracture, break or warp during or after the batten has been fastened to the structure. If a hydraulic seal is a mandatory requirement of the attachment, the batten should have sufficient rigidity to maintain a seal between the designed spacing of the bolts.

**8.2.1.2 Type of Bolts**—The bolts should be made of a material capable of fulfilling the design life of the attachment. The bolts should be made of a material capable of withstanding the torque required to secure the batten to the structure. Wedge anchors holes must be carefully drilled to assure the grip necessary to develop the pullout resistance required for sealing the gasket and geomembrane to the structure. Adhesive (epoxy) anchors, properly installed, may provide a more reliable alternative to wedge anchors.

**8.2.1.3 Number of Bolts**—The battens should have a sufficient number of bolts to secure the batten and geomembrane to the structure without damaging the sealants and geomembrane.

Cover batten strips with 4 layers of 8-ounce geotextile to protect liner (typical).

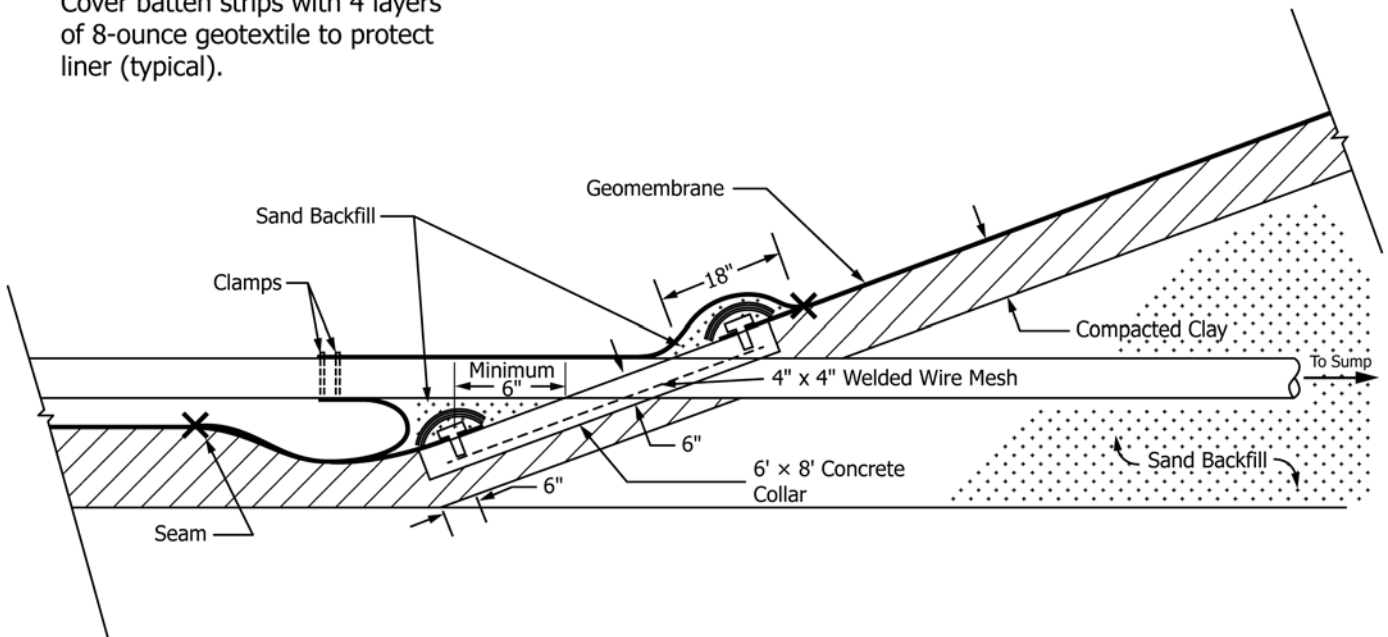

FIG. 6 Liner Penetration Detail

Note: There are many different types of tank corner details. However, any corner design should support the geomembrane and alleviate possible geomembrane stresses during tank use.

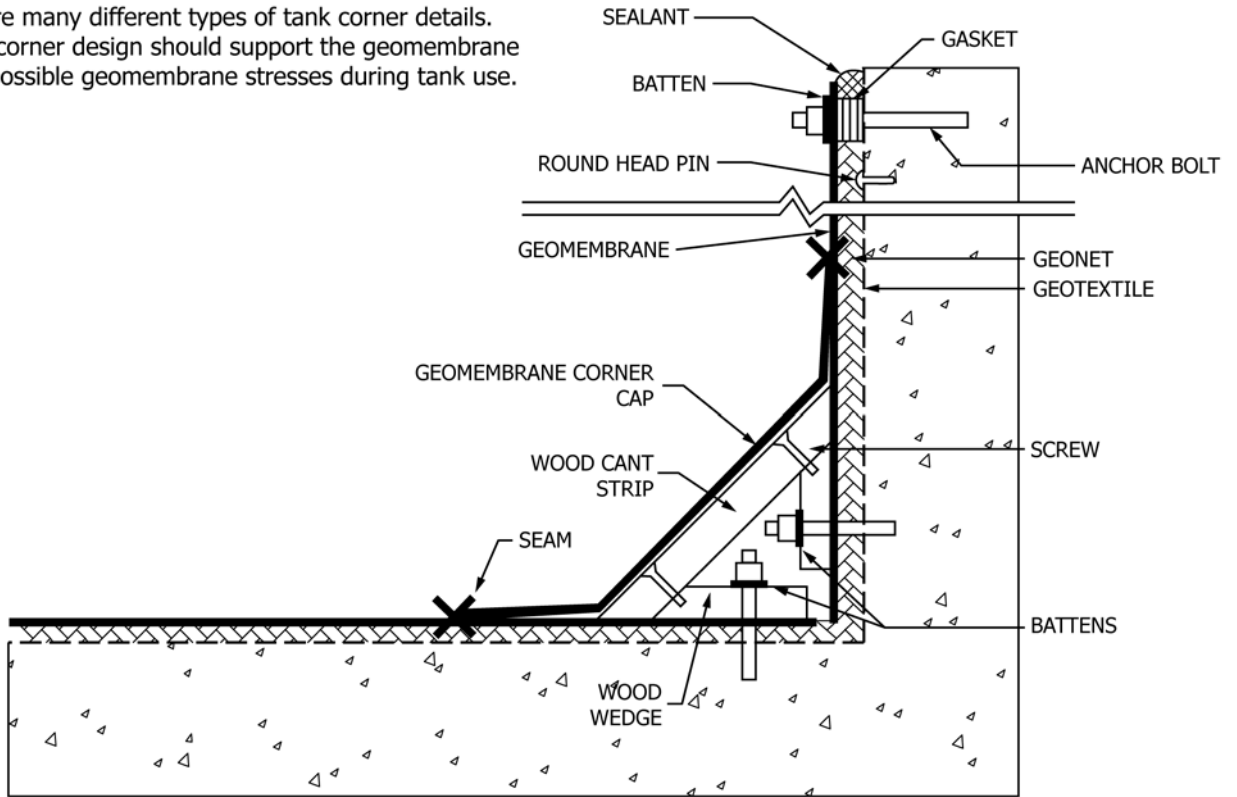
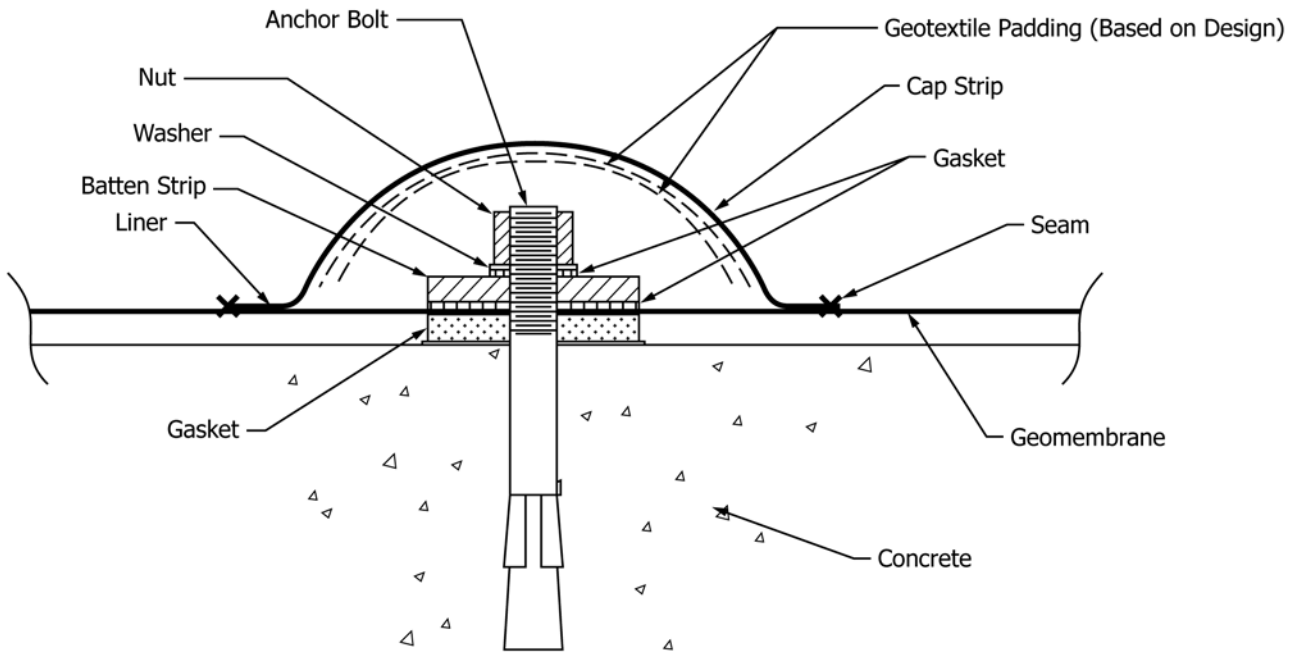

FIG. 7 Tank Corner Detail



NOTE:

1. A length of bolt extending above the clamping nut must be limited to 2–3 threads exposed when tightening or torquing is finished.
2. An "Acorn" can be used to round off top of bolt. However, the number of threads exposed above the batten strip is critical to assure tightening of the nut.

FIG. 8 Batten Attachment with Cap Strip

If the batten is used to attach the geomembrane to a vertical wall, the number of bolts should be sufficient to develop sufficient strength to support the geomembrane.

8.2.1.4 *Bolt Spacing*—If a seal is a mandatory requirement of the attachment, the bolt spacing should be sufficient to allow the batten and geomembrane to be secured to the structure without warping of the batten and limiting the functionality of the sealant or geomembrane between bolts, or both.

8.2.1.5 *Torque*—Sufficient torsional force should be applied to the bolt to secure the batten and geomembrane to the structure without damaging the batten, geomembrane, sealant, or structure.

NOTE 1—The amount of torque applied to the bolt can be compromised by the bolt thread condition, cleanliness (dirt in threads), nicks in the threads and calibration of the torque wrench. If a gasket of known thickness and hardness (for example, durometer value) is used as a sealant, a predetermined reduction of thickness of the gasket (10 to 15 %) may provide a reliable method of applying the required compression force onto the clamps or battens.

8.2.2 *Clamps*—Clamps can be made of polymer or steel. The clamp must remain functional for the design life of the attachment. The clamp should have sufficient strength and rigidity to fasten the geomembrane to the structure by applying sufficient torque to the bolts or force on the clamps. The clamp should not be capable of elongating over time and, thereby, weakening the attachment. If a seal is a mandatory requirement of the attachment, the clamp should not be over tightened to the extent of damaging the sealant.

8.2.3 *Gaskets*—The chemical compatibility of the gasket material should be considered.

8.2.4 *Rondels*—The rondel should be embedded into the concrete to a depth to allow a smooth transition between the concrete surface and top of the rondel. The concrete should be allowed to cure to the design requirements or according to the specifications before attaching of the geomembrane to the rondel.

NOTE 2—The user should contact the rondel manufacturer regarding specific rondel designs and installation procedures.

8.3 *Void Space*—The size and number of voids around or near the attachment should be limited. If voids cannot be eliminated, it is recommended that the voids be filled to limit the ability of the geomembrane to deform into the void(s). Deformation into the voids by the geomembrane may increase the possibility of weakening and damaging the attachment.

## 9. Factory Pre-Fabricated Boots, Corners and Edges

9.1 Many manufacturers or installers, or both, produce factory pre-fabricated boots, corners and edges that ease the geomembrane installation process and, thereby, increase the quality of the finished project. Boots, corners, and edges pre-fabricated in a controlled factory environment are considered to be of higher quality than the field fabricated, which are subject to ambient field conditions. Some manufacturer's factory pre-fabricated boots are designed to allow for field testing for increased construction quality control/assurance or reduce void space within the boot attachment, or both. Factory pre-fabricated corners and edges can reduce the overlapping of geomembrane and increase the integrity of the geomembrane

attachment. Edges and corners can also be pre-fabricated of thicker/stronger geomembrane material for these critical areas.

## 10. Shape, Size, and Proximity of Penetrations

10.1 *Shape*—The shape of the penetration should be considered in the design or installation, or both, of the geomembrane attachment. For example the design to use a geomembrane under a building constructed on top of pilings or within a reservoir with support columns, many pilings or columns have a square or odd shape. The attachment of the geomembrane to one or more of these pilings or columns could be a difficult installation that requires excessive labor and materials to complete. The difficulty of the attachment may also decrease the ability to obtain a sufficient liquid/vapor barrier. Changing the shape of the penetration may alleviate this problem. By requiring the pilings or columns to be round is a solution. Another alternative is to pour a concrete collar around the piling or column at the location of the attachment. Clamps or banding straps (see 5.2) can then be used to achieve a quick and sufficient attachment.

10.2 *Size*—The size of the penetration can create significant difficulty constructing a geomembrane attachment. Usually penetrations smaller than 50 mm in diameter are difficult to construct. It is recommended that the designer or installer review alternatives that will allow the size of the penetration to increase and reduce the difficulty of the attachment. Fig. 9 is an example of such an alternative. In this figure, several small pipes or wires, or both, are brought through a larger pipe, which allows a less difficult attachment. The annular space between the pipes or wires, or both, is grouted, thus creating a liquid/vapor barrier.

10.3 *Proximity*—The proximity of each penetration should be considered in developing a geomembrane attachment. Penetrations in close proximity to each other can be difficult to construct an attachment. The flexibility of the geomembrane, the working environment, size of penetration, and type of attachment should be reviewed as part of the design and installation. If possible, it is recommended that penetrations should be spaced a minimum of 1 m apart from each other. If this is not possible other alternatives should be investigated. Fig. 9 shows how several penetrations were brought together to make one penetration.

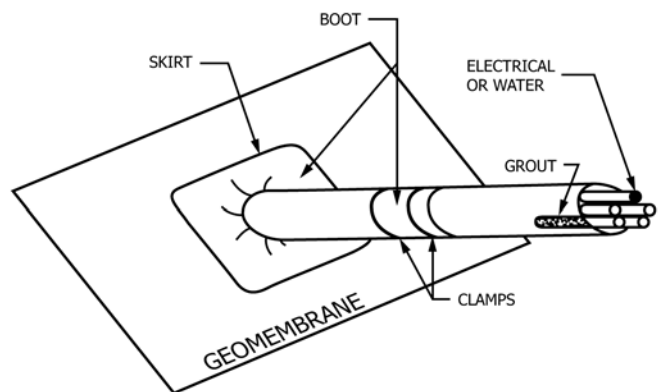

FIG. 9 Pipe Penetration Detail



## 11. Examples of Attachments

11.1 This guide includes Figs. 10-15 that show examples of various geomembrane attachments to penetrations or structures. These figures do not address all problems or situations a geomembrane installer or design engineer may face in the attachment of geomembranes to structures, pipes, etc. The purpose of the figures is to illustrate typical attachments. It is the geomembrane installer or the design engineer or both, that must determine the design intent of the geomembrane attach-

ment and design/construct the attachment to meet that design intent. Additions or deletions of various items noted within the figures may be required to meet the design intent. It is the responsibility of the geomembrane installer or design engineer, or both, to make that determination.

## 12. Keywords

12.1 attachment; batten; concrete; gasket; geomembrane; geotextile; rondel; sealant; structure

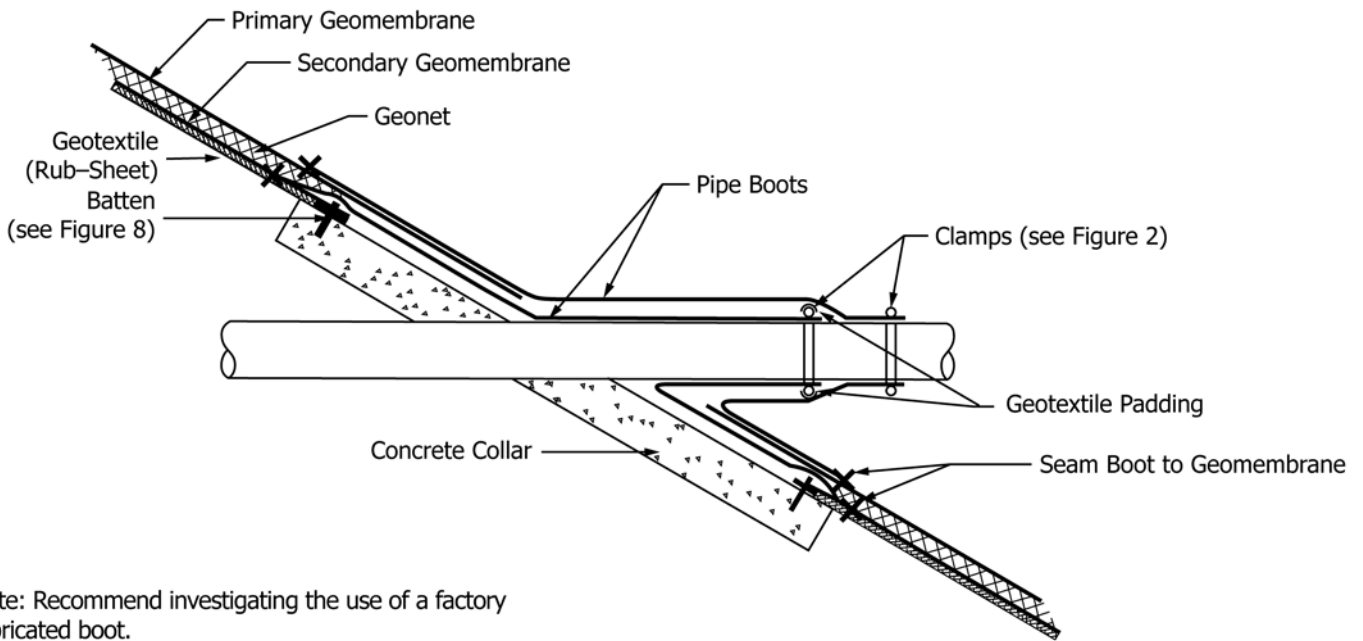

FIG. 10 Pipe Penetration—Double Layer System with Collar

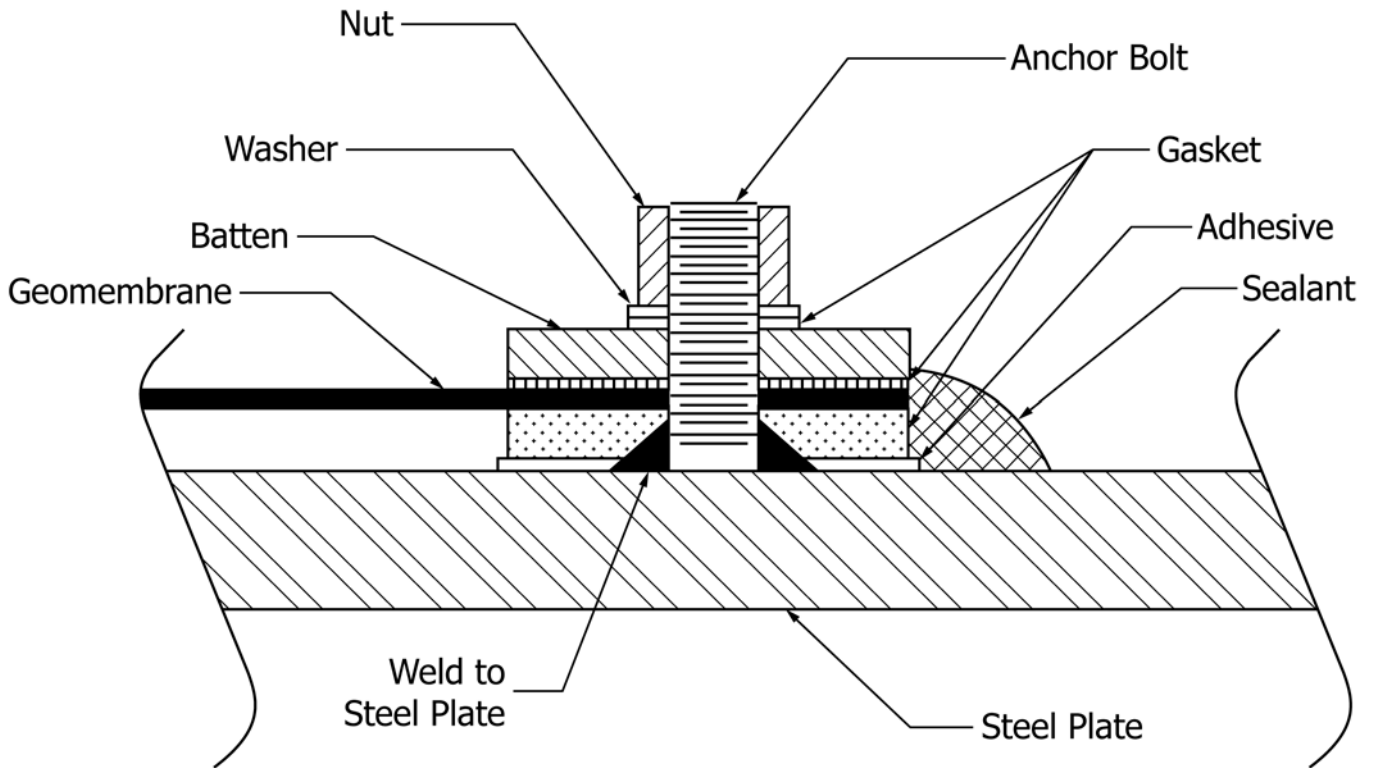
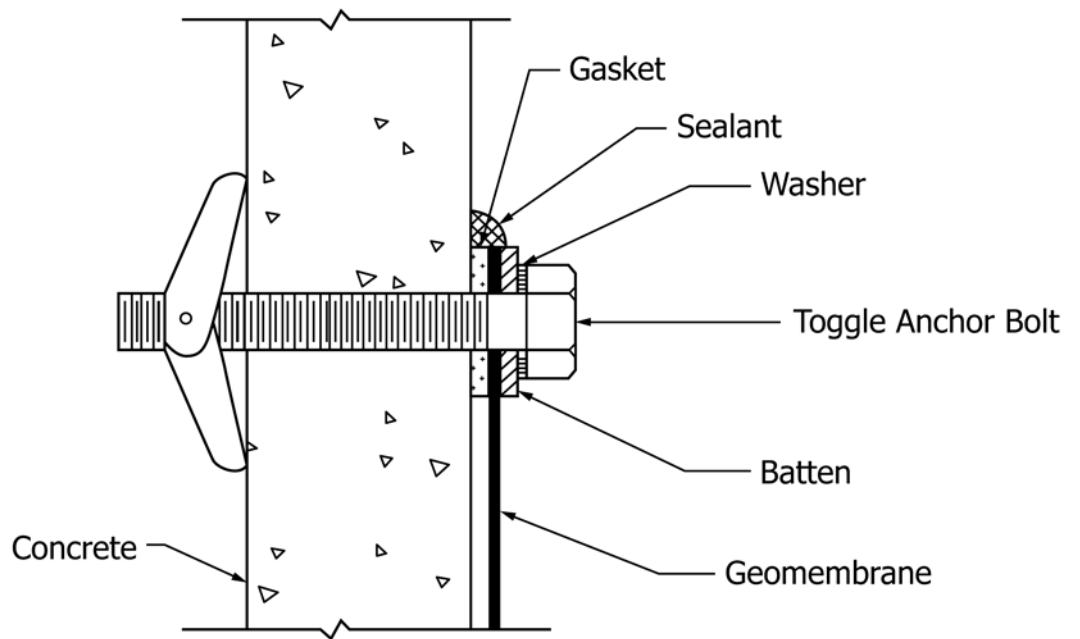

FIG. 11 Batten Attachment to Steel Plate



Note: This type of anchor is normally used in a masonry wall or thin concrete wall.

FIG. 12 Batten Attachment

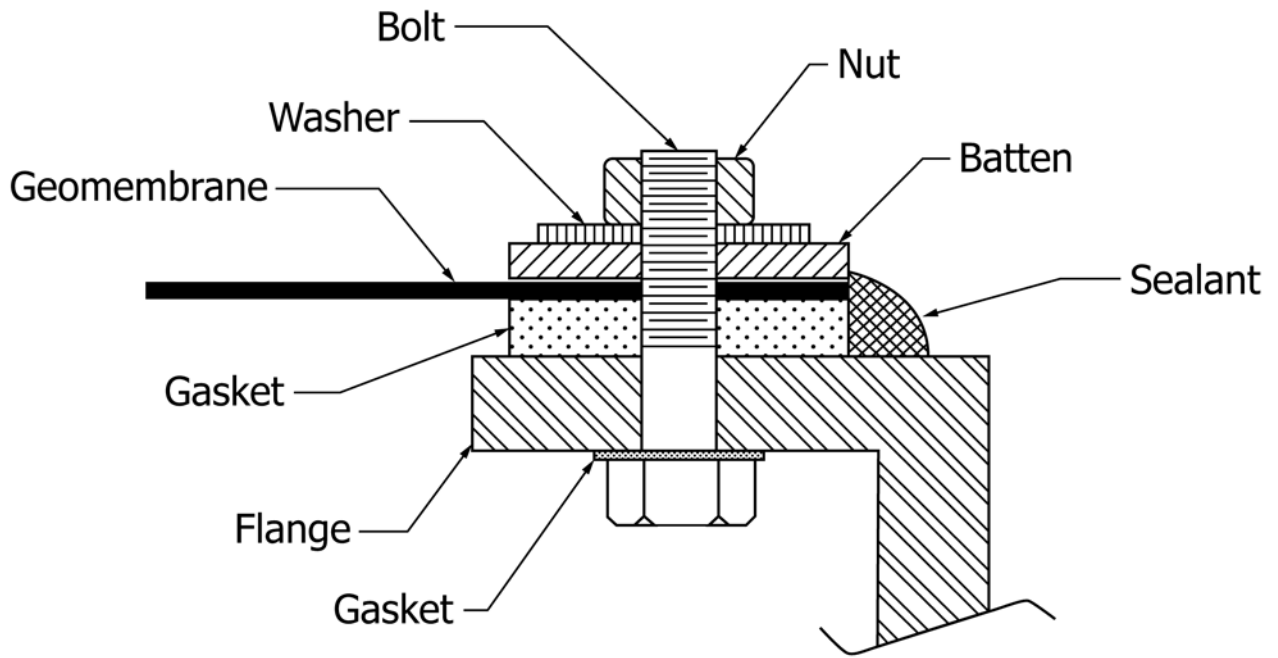

FIG. 13 Batten Attachment to Flange

Note: Pipe flange should be ground to a bevel before it is welded to pipe.

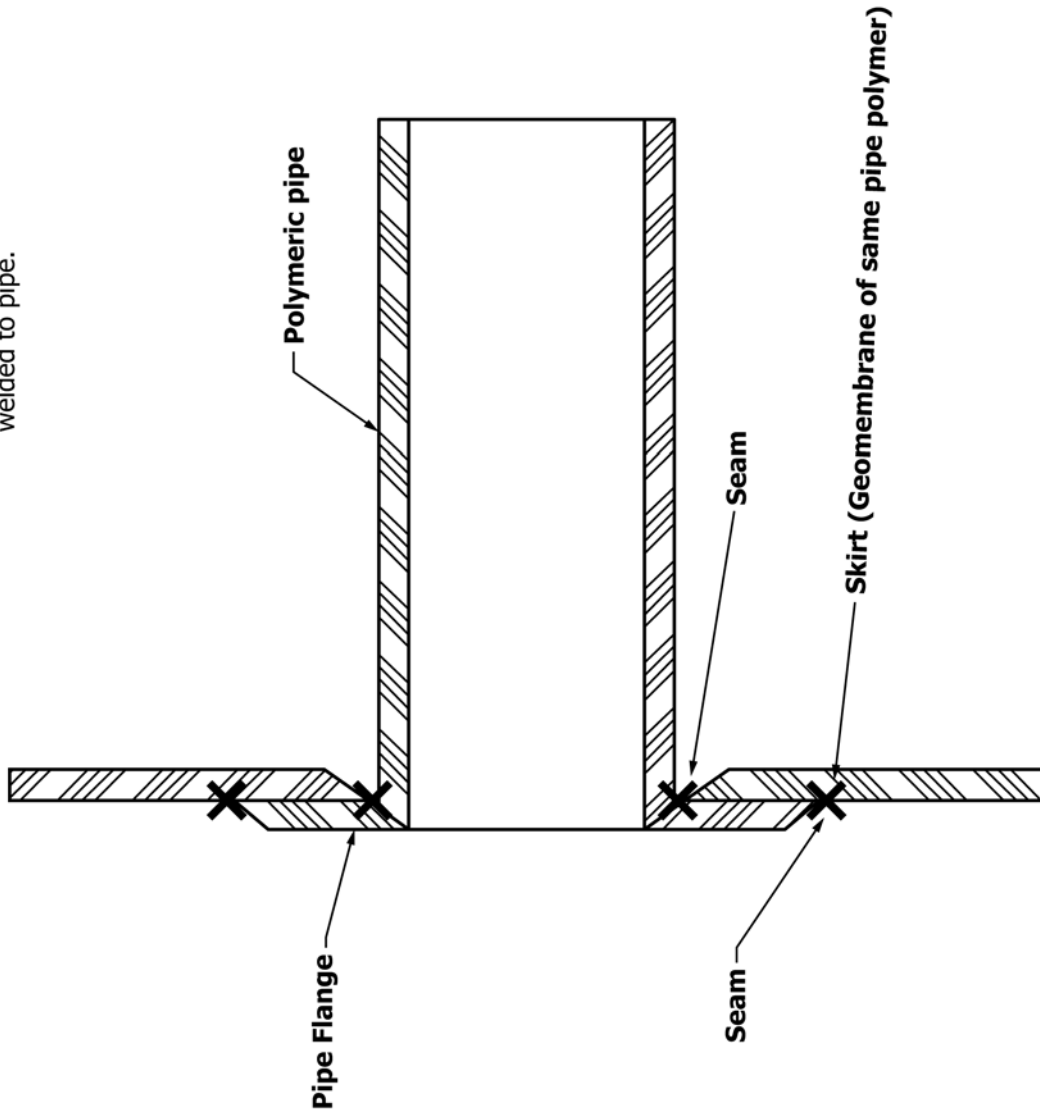
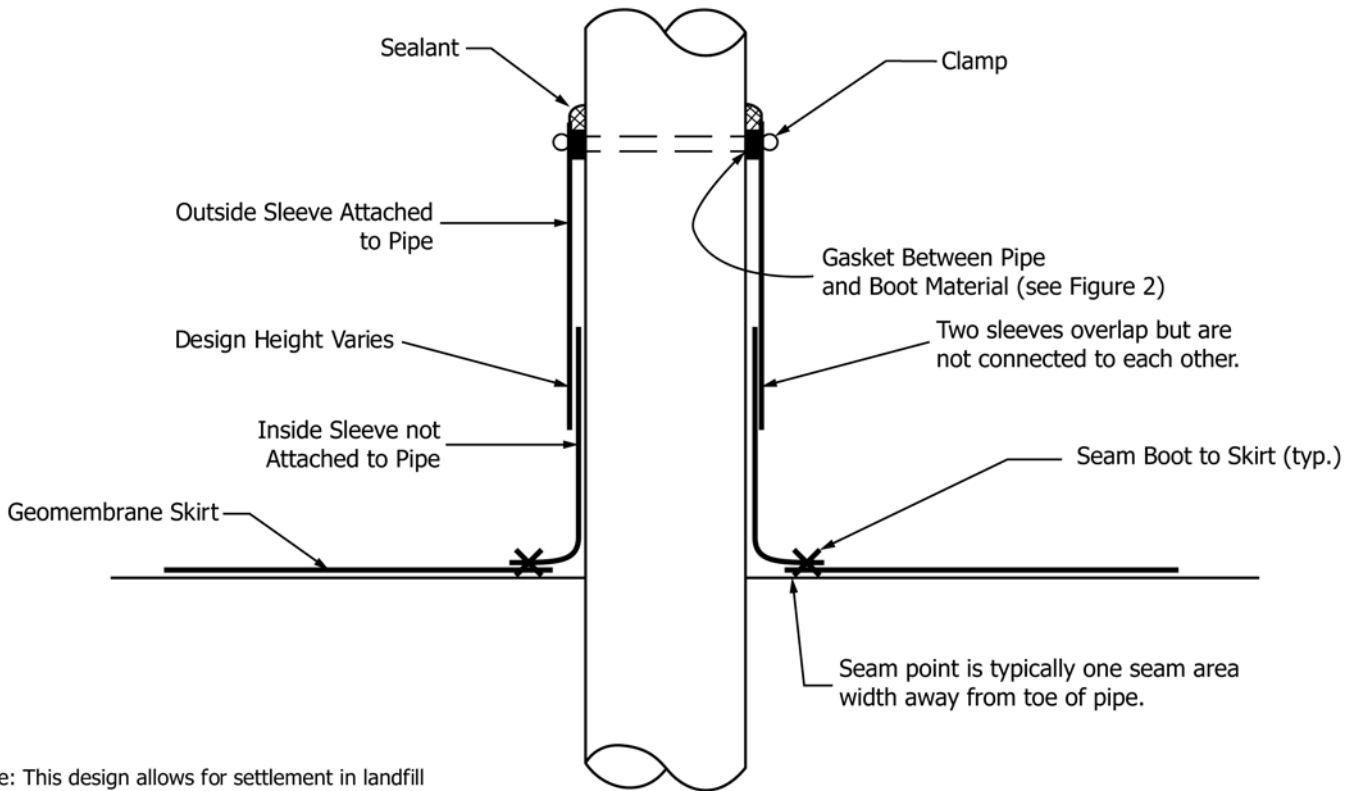

FIG. 14 Pipe Boot



Note: This design allows for settlement in landfill caps/closures by allowing the inside sleeve to slide down under the outside sleeve.

FIG. 15 Slip Boot Detail

ASTM International takes no position respecting the validity of any patent rights asserted in connection with any item mentioned in this standard. Users of this standard are expressly advised that determination of the validity of any such patent rights, and the risk of infringement of such rights, are entirely their own responsibility.

This standard is subject to revision at any time by the responsible technical committee and must be reviewed every five years and if not revised, either reapproved or withdrawn. Your comments are invited either for revision of this standard or for additional standards and should be addressed to ASTM International Headquarters. Your comments will receive careful consideration at a meeting of the responsible technical committee, which you may attend. If you feel that your comments have not received a fair hearing you should make your views known to the ASTM Committee on Standards, at the address shown below.

This standard is copyrighted by ASTM International, 100 Barr Harbor Drive, PO Box C700, West Conshohocken, PA 19428-2959, United States. Individual reprints (single or multiple copies) of this standard may be obtained by contacting ASTM at the above address or at 610-832-9585 (phone), 610-832-9555 (fax), or service@astm.org (e-mail); or through the ASTM website (www.astm.org). Permission rights to photocopy the standard may also be secured from the Copyright Clearance Center, 222 Rosewood Drive, Danvers, MA 01923, Tel: (978) 646-2600; http://www.copyright.com/