



Standard Test Method for Flatwise Flexural Impact Resistance of Rigid Plastics¹

This standard is issued under the fixed designation D6395; the number immediately following the designation indicates the year of original adoption or, in the case of revision, the year of last revision. A number in parentheses indicates the year of last reapproval. A superscript epsilon (ϵ) indicates an editorial change since the last revision or reapproval.

1. Scope*

1.1 The resistance of plastics to breakage by flexural shock may be determined by test methods such as those contained in Test Method [D256](#). Specimens used in those test methods feature a milled notch to promote brittle fracture. The test specimens are struck by a pendulum with the depth dimension parallel to the direction of pendulum swing. This test method is differentiated from the others by its application to the assessment of the affect on impact resistance of changes in the surface of specimens resulting from weathering or other exposure. In this test method, specimens are struck by a pendulum with the depth dimension perpendicular to the direction of pendulum swing. Test Method [D5420](#) may also be used to conduct testing of weathered or exposed specimens. This test method is differentiated from Gardner Impact by the smaller size of the specimens, which may result in substantially higher productivity of accelerated weathering instruments. Additionally, this test method provides multiple data from a single specimen for characterization of within specimen variability.

1.2 This test method describes the determination of the resistance of rigid plastic strip specimens to breakage or permanent deformation when one end of the specimen is subjected to an impact upon its wide face while the other end of the specimen is firmly clamped.

1.3 This test method is applicable to specimens of 1.60 mm (0.0625 in.) thickness. However, the limits of applicability of the test are not sharply defined, and specimens having other dimensions may frequently be used. For specimens of thicknesses other than 1.60 mm (0.0625 in.) the ratio of the distance between the top of the clamp and the centerline of the rounded striking edge to the specimen thickness must be 2.5 ± 0.1 .

1.4 This test method measures the relative impact resistance of samples having approximately the same thickness. Normalization of the impact resistance to unit cross-sectional area only partly compensates for the effects of specimen thickness variation because, at the fixed cantilever length, the ratio of

shear stress to tensile stress in bending increases with thickness, and the importance of these effects in contributing to the energy absorbed is greater for ductile than for brittle failure.

1.5 This test method is used primarily as a means of assessing, for a series of samples, changes relative to a control due to some treatment such as weathering or exposure to active environments. It has been particularly useful as a sensitive indicator of the development of surface cracks or a brittle surface. The existence or formation of cracks in an inherently brittle surface produces marked lowering of impact strength when that surface is the one subjected to tension in the test.

1.6 This test method is not generally applicable to materials such as elastomers or nonrigid plastics in which there is no fracture, permanent deformation, or other change due to yielding in flexure. However, it may be desirable to test such materials as file samples to establish reference points when the test is applied as described in [1.5](#).

1.7 The values stated in SI units are to be regarded as the standard. The values given in parentheses are for information only.

1.8 *This standard does not purport to address all of the safety concerns, if any, associated with its use. It is the responsibility of the user of this standard to establish appropriate safety and health practices and determine the applicability of regulatory limitations prior to use.*

NOTE 1—There is no known ISO equivalent to this standard.

2. Referenced Documents

2.1 *ASTM Standards*:²

[D256 Test Methods for Determining the Izod Pendulum Impact Resistance of Plastics](#)

[D618 Practice for Conditioning Plastics for Testing](#)

[D883 Terminology Relating to Plastics](#)

[D5420 Test Method for Impact Resistance of Flat, Rigid Plastic Specimen by Means of a Striker Impacted by a Falling Weight \(Gardner Impact\)](#)

[D5947 Test Methods for Physical Dimensions of Solid Plastics Specimens](#)

¹ This test method is under the jurisdiction of ASTM Committee [D20](#) on Plastics and is the direct responsibility of Subcommittee [D20.10](#) on Mechanical Properties.

Current edition approved April 1, 2011. Published April 2011. Originally approved in 1999. Last previous edition approved in 2010 as D6395 - 10. DOI: 10.1520/D6395-11.

² For referenced ASTM standards, visit the ASTM website, www.astm.org, or contact ASTM Customer Service at service@astm.org. For *Annual Book of ASTM Standards* volume information, refer to the standard's Document Summary page on the ASTM website.

*A Summary of Changes section appears at the end of this standard

3. Terminology

3.1 Definitions used in this test method are in accordance with Terminology **D883**.

4. Significance and Use

4.1 The flatwise flexural impact test is a test in which the kinetic energy lost by a moving pendulum during impact is used to determine the energy to break or deform a test specimen.

4.2 The standard Izod test apparatus as described in Test Method **D256** is retrofitted with clamping jaws, which hold the test specimen such that the flat face of the specimen is struck by the pendulum during a test.

4.3 The pendulum shall be a standard Izod pendulum as described in Test Method **D256**. It shall be capable of delivering an energy of 2.71 ± 0.14 J (2.00 ± 0.10 ft.-lbf). Except as detailed in **10.5**, this basic pendulum shall be used with all specimens that extract less than 85 % of the available energy. Higher energy pendulums or a basic pendulum to which weights are added to increase its available energy shall be used with specimens that require more energy to break. A series of energy levels such that each has twice the energy of the next lighter one will be found convenient. The striking nose of the pendulum shall contact one of the flat faces of the specimen at a specified distance above the clamp edge. The ratio of the distance between the top of the clamp and the centerline of the rounded striking edge to the specimen thickness shall be 2.5 ± 0.1 .

4.4 The type of failure of each specimen tested shall be assigned one of the following categories:

Complete Break (C)—A break in which the specimen is separated into two or more pieces.

Hinge Break (H)—A nearly complete break in which there is little or no spring back when the free end is bent or displaced.

Partial Break (P)—An incomplete break in which fracture extends through at least 50 % of the specimen thickness, and such that the free end can be bent with relatively little effort yet has considerable spring back.

Nonbreak (N)—A result where there is no fracture or the fracture extends less than 50 % of the specimen thickness.

4.5 The value of this impact test is to determine the change in impact properties that may result from a material having been exposed to one or a series of environments, such as weathering at different intervals or different intensities when these data are compared to a file sample exposed only to the standard laboratory environment or other agreed upon conditions.

4.6 The flatwise impact resistance is calculated as energy absorbed per unit of cross-sectional area.

4.7 Before proceeding with this test method, reference should be made to the specification of the material being tested. Any test specimen preparation, conditioning, dimensions, and/or testing parameters covered in the material specification shall take precedence over those mentioned in this test method except in cases where to do so would conflict with the purpose

for conducting testing. If there are no material specifications, then the default conditions apply.

5. Interferences

5.1 Use of an improper shim will result in test values either too large or too small depending upon whether the shim in use is too short or too long.

5.2 Orientation and molded-in stresses due to flow and cooling history result in variation in properties within injection molded specimen, especially at the ends and at the gate region. The effects of such variations can be minimized by avoiding tests close to the gate or the ends of the specimen.

5.3 The clearance between the pendulum and the clamp as the pendulum passes the clamp at its closest point during a test significantly affects the results of this test. If the specimen thickness is greater than about one half of the clearance, a large energy loss due to friction occurs in ductile specimens. The ratio of shear to surface tensile stress increases and the nature of failure may change abruptly over a narrow range of specimen thickness. The clearance is dictated by the ratio of the distance between the pendulum nose centerline and the clamp top to the specimen thickness (2.5 ± 0.1). The movable jaw face and fixed jaw face set used for the thickness of specimen being tested shall either be of proper dimensions for this ratio or be adjustable in design to allow the ratio to be achieved.

5.4 The use of excessive clamping force may induce stresses in test specimens causing variation in test results.

6. Apparatus

6.1 *Testing Machine*—The testing machine shall consist of the standard Izod test instrument as detailed in Test Method **D256** but with a modified clamping arrangement. **Figs. 1-3** illustrate typical clamping arrangements applicable to some instruments. Other clamping arrangements may be used provided that they maintain the specified ratio of the distance between the top of the clamp and the centerline of the pendulum nose to the specimen thickness (2.5 ± 0.1). Other arrangements must also provide uniform clamping along the clamped length of the specimen and position the specimen such that when the pendulum is freely hanging, the striking edge is within 0.2 % of full scale of touching the front face of the specimen as required by Test Method **D256**. As indicated by these figures, the specimen clamp faces may be bolted or otherwise firmly attached to the existing Izod fixed and movable jaws. To avoid compromising the instrument's capability for Izod testing, using either a dedicated set of fixed and movable Izod jaws or clamping faces mounted in such a way as to not alter the existing Izod jaws is recommended.

6.2 *Specimen Clamp Faces*—Special clamp faces (see **Fig. 2**) for both the fixed and the movable jaws of the clamp shall be used to clamp the test specimen flatwise with its long axis vertical and its thickness direction parallel to the direction of the pendulum swing. The clamp faces constitute a set. Some dimensions within the set are dictated by the thickness of the specimen being tested and by the particular Izod instrument being used. **Fig. 2** provides the dimensions for clamp faces

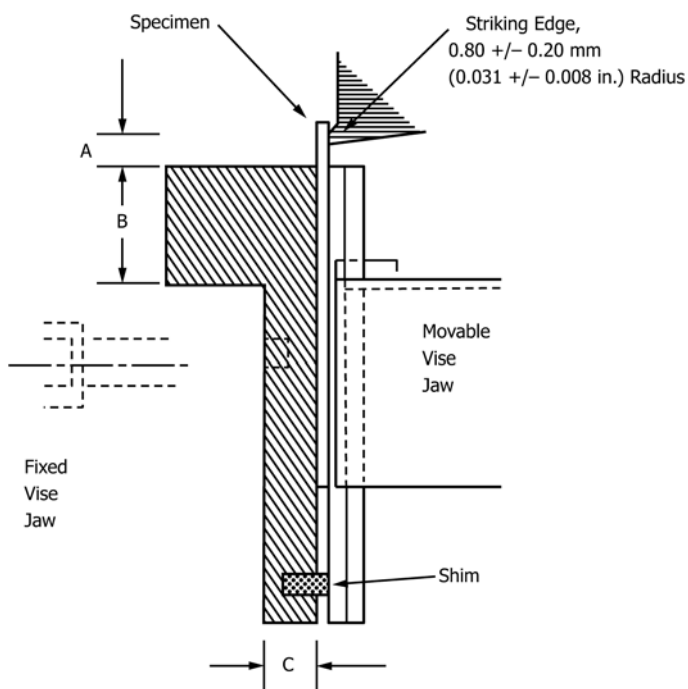

- Dimensions**
- A = 4.00 mm (0.161 in.) for 1.60 mm (0.062 in.) thick specimen.
 - B = The value of dimension B is determined by the particular Izod instrument used. Select dimension B as required to achieve dimension A for the specimen thickness being tested.
 - C = The value of dimension C is determined by the thickness of the specimen to be tested. It is calculated by subtracting the specimen thickness from 12.7 mm (0.5 in.).

- Legend**
- A = Distance between clamp top and center line of rounded striking edge,
 - B = Height of clamp top above fixed jaw of vise, and
 - C = Thickness of fixed jaw face.

FIG. 1 Typical Specimen Clamping Device

when used with one type of Izod instrument to test 1.60 mm (0.062 in.) thick specimen.

6.2.1 For 1.60 mm (0.062 in.) thick specimens the distance between the upper edge of the clamp and the striking nose of the pendulum is 4.0 mm (0.161 in.) providing a clearance between the clamp and the lowest part of the pendulum's striking nose of 3.20 mm (0.126 in.).

NOTE 2—The required dimensions of hardware may vary from those provided in the figures as a result of individual tolerances necessary to mate with preexisting components. The cumulative tolerances of individual hardware components must result in the required ratio of the distance between the top of the clamp and the centerline of the rounded striking edge to the specimen thickness of 2.5 ± 0.1 .

6.3 *Shims*—A set of steel blocks (see Fig. 3) shall be used to provide spacing between the lower end of the jaw faces to keep the faces as parallel as possible during testing. A shim shall be selected to provide a spacing between the clamp faces matched as closely as possible to the thickness of the specimen being tested. In no case shall the shim protrude beyond the jaw face by less than the specimen thickness or insufficient clamping of the specimen may result. Fig. 3 provides the dimensions for a

set of shims spanning a typical range of thickness for the testing of 1.60 mm (0.0625 in.) thick specimen.

6.4 *Micrometers*—Suitable micrometers with a resolution of 0.025 mm (0.001 in.) or better shall be used to measure the thickness of the test specimen. The micrometer shall conform to the applicable provisions of Test Method D5947.

7. Sampling, Test Specimen, and Test Units

7.1 The standard test specimen shall have a rectangular cross-section and an approximate length of 65 mm (2.5 in.). Most specimens should be 12.7 mm (0.500 in.) wide by 1.60 mm (0.0625 in.) thick, but for some materials, such as those which are glass reinforced, it may be desirable to use specimens of other thicknesses. The specimens may be molded or cut from flat sheet, but they shall be of uniform dimensions within any given set.

7.2 Trim or sand off any protrusions that might interfere with clamping or positioning the specimen in the instrument clamps. Do not introduce notches or scratches in the test face of the specimen.

7.3 Injection-molded specimens shall have at least 6 mm (0.25 in.) cut from the end to be tested first so that when the specimen is clamped in the testing machine, the clamp edge will be no less than 12 mm (0.5 in.) from the original end of the specimen. The clamp edge shall also be at least 6 mm (0.25 in.) from a gate. Whenever this test is used for assessing aging effects, cut off any portion of the test specimen end which has not been uniformly exposed to the aging environment so that the edge of the clamp will be at least 6 mm (0.25 in.) from the unexposed region.

8. Calibration and Standardization

8.1 Check the flatwise impact tester periodically for conformance to the provisions of Test Method D256.

8.2 The proper movable jaw face, fixed jaw face, and shim shall be installed for the thickness of the specimen being tested. The dimensional relationships between the various combinations of hardware components for a 1.60 mm (0.0625 in.) thick specimen is provided in Fig. 1.

8.3 The clearance between the pendulum and the upper grip surface at their closest point shall be checked frequently to confirm that the correct clearance is being used for the thickness of the specimen being tested and that the clearance plus striker radius meets the required ratio.

8.4 Adequate file samples for each group of treated samples shall be tested, preferably at the same time that the treated samples are tested.

9. Conditioning

9.1 *Conditioning*—Condition the test specimens at $23 \pm 2^\circ\text{C}$ ($73.4 \pm 3.6^\circ\text{F}$) and $50 \pm 10\%$ relative humidity for not less than 40 h prior to test in accordance with Procedure A of Practice D618, unless otherwise specified by contract or relevant material specification, or unless it has been shown that conditioning is not necessary. In cases of disagreement, the tolerances shall be 1°C (1.8°F) and $\pm 5\%$ relative humidity.

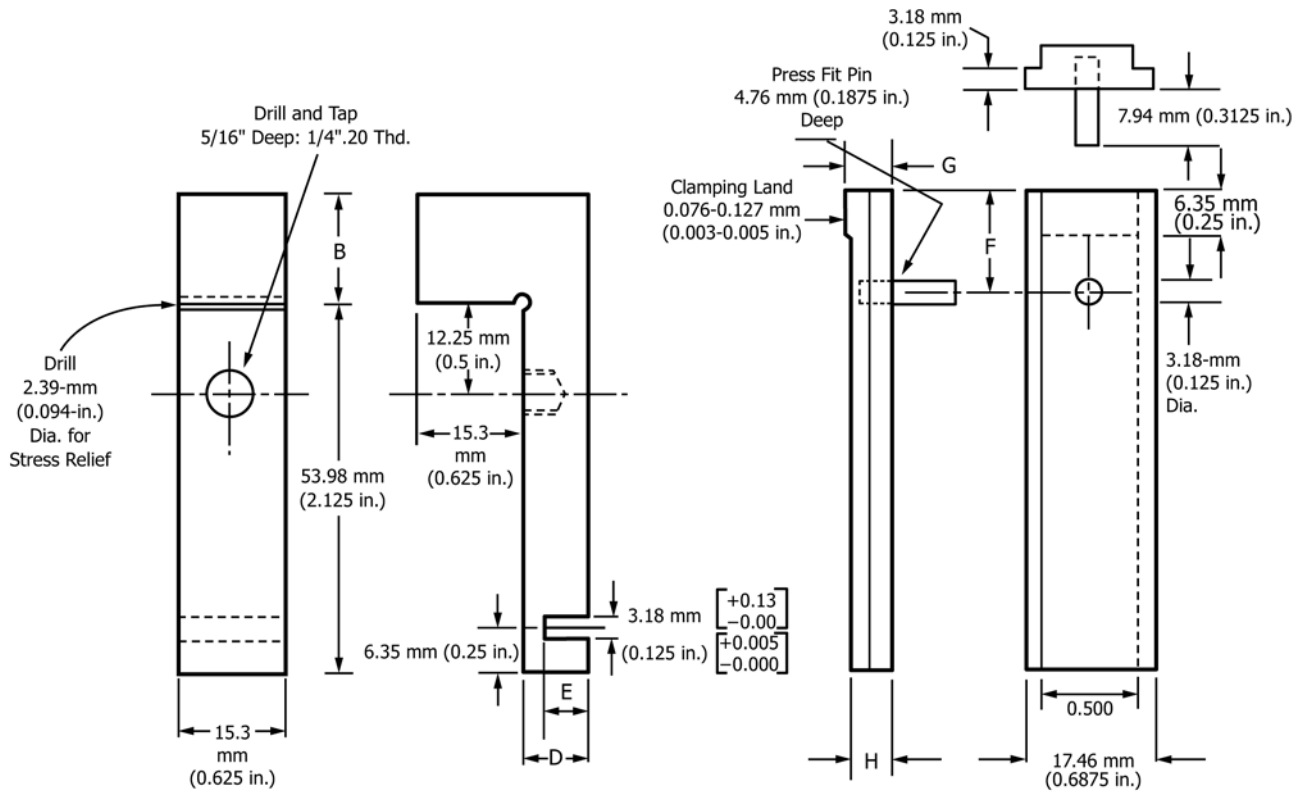

Dimension	Specimen Thickness
B	17.91 mm (0.705 in.)
D	9.53 mm (0.375 in.)
E	6.35 mm (0.250 in.)
F	19.18 mm (0.755 in.)
G	6.45 mm (0.254 in.)
H	6.32 mm (0.249 in.)

FIG. 2 Faces for Clamp Jaws

9.2 Test Conditions—Conduct tests in the standard laboratory atmosphere of $23 \pm 2^\circ\text{C}$ ($73.4 \pm 3.6^\circ\text{F}$) and $50 \pm 10\%$ relative humidity, unless otherwise specified by the contract or relevant material specification. In cases of disagreement, the tolerances shall be 1°C (1.8°F) and $\pm 5\%$ relative humidity.

10. Procedure

10.1 Test a minimum of two specimens. Measure and record the width and thickness of each specimen to the nearest 0.025 mm (0.001 in.) by taking a single width measurement and a single thickness measurement in the center of the longitudinal axis.

10.2 Select a movable jaw face and fixed jaw face set, shim appropriate to the thickness of the specimen being tested, and install them on the test instrument. The shim selected shall be

inserted in the slot of the fixed jaw face. It shall provide spacing closest to, but not less than, the measured thickness of the test specimen.

10.3 Position the specimen in the center of the clamp jaws and activate the clamp to hold it. For 1.60 mm (0.063 in.) thick material, the specimen should extend 6 to 7 mm (0.25 in.) above the upper surface of the clamp. It has been determined that the suitable extension of the specimen from the clamp for some other thicknesses of specimens are as follows. For 2.54 mm (0.100 in.) thick material, the specimen should extend 8 to 9 mm (0.325 in.) above the upper surface of the clamp. For 3.18 mm (0.125 in.) thick material, the specimen should extend 9 to 10 mm (0.375 in.) above the upper surface of the clamp. For 4.46 mm (0.175 in.) thick material, the specimen should extend 12 to 13 mm (0.500 in.) above the upper surface of the

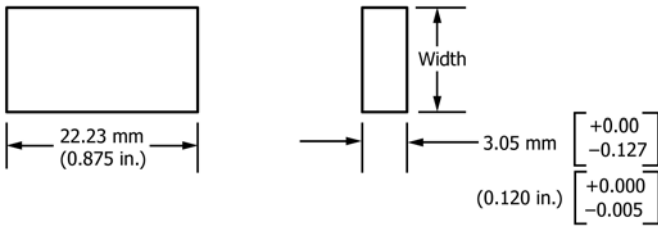

Spacing Resulting When Shim is Used
Specimen Dimension

Shim Number	Shim Width	Specimen Dimension
	1.60 mm (0.0625 in.)	
1	7.87 mm (0.310 in.)	1.52 mm (0.060 in.)
2	8.00 mm (0.315 in.)	1.65 mm (0.065 in.)
3	8.13 mm (0.320 in.)	1.78 mm (0.070 in.)
4	8.26 mm (0.325 in.)	1.91 mm (0.075 in.)
5	8.38 mm (0.330 in.)	2.03 mm (0.080 in.)
6	8.51 mm (0.335 in.)	2.16 mm (0.085 in.)

NOTE 1—Shim widths shown are nominal. The actual width of any particular shim is not of critical importance. The difference between any two adjacent shims in a given set shall be 0.127 ± 0.0127 mm (0.005 ± 0.0005 in.).

FIG. 3 Jaw Spacing Shims

clamp. For specimens aged in environments such as outdoor weathering or in an accelerated weathering device, clamp the specimen so that the test face is the exposed surface, unless otherwise specified.

NOTE 3—Positioning a 1.60 mm (0.0625 in.) thick specimen for successive tests along its length can be made more efficient by placing index marks at 6 to 7 mm (0.25 in.) intervals on the face opposite the test face, or by providing a positioning fixture. A 2.54 mm (0.100 in.) thick specimen can be positioned using index marks at 8 to 9 mm (0.325 in.) intervals. A 3.18 mm (0.125 in.) thick specimen can be positioned using index marks at 9 to 10 mm (0.375 in.) intervals. A 4.46 mm (0.175 in.) thick specimen can be positioned using index marks at 12 to 13 mm (0.500 in.) intervals.

10.4 Tighten the clamp sufficiently to hold the specimen firmly. If the specimen is not held tightly at the upper edges of the jaws, change the shim to the next increment to provide wider spacing.

10.5 Release the pendulum and record the indicated breaking energy of the specimen (corrected for windage and friction—see Test Method D256) and also the type of failure as described in 4.4. Unless the correct energy pendulum has been previously established, the first test should be attempted using the basic 2.71-J pendulum to test file specimen. If the resulting expended energy is greater than 85 % of the available energy, discard this test result and change to a pendulum with higher energy for the second test such that the expended energy is equal to or less than 85 % of the available energy. After applying the criteria for pendulum selection, if the second impact test is classified as a no break, choose a pendulum of higher available energy, conduct the remaining tests for the file sample, and report comments regarding what pendulums were used with each test. When an incomplete break occurs the pendulum should be manually caught (or hammer break engaged) before it strikes the test specimen on its return swing.

10.6 For each subsequent test of weathered or exposed specimen, reposition the specimen as in 10.3 and repeat 10.4

and 10.5 with the exception that the pendulum shall not be changed during the testing of specimens of a given sample after the initial test.

11. Calculation or Interpretation of Results

11.1 Determine the pendulum energy correction using windage and friction factors as detailed in Test Method D256. Subtract the energy correction from the indicated energy to obtain a compensated energy value. Use the compensated value in the equation below to determine the impact resistance.

11.2 Calculate the impact resistance for each impact of a specimen by the following equation:

$$\text{impact resistance, kJ/m}^2 \text{ (ft} \cdot \text{lbf/in.}^2\text{)} = \frac{E}{w \times t} \quad (1)$$

where:

E = energy, kJ (ft-lbf) (corrected for windage and friction),
 w = width, m (in.), and
 t = thickness, m (in.),

NOTE 4—kJ/m² can be converted to ft-lbf/in.² by dividing the result in kJ/m² by 2.102.

12. Report

12.1 Report the following information:

12.2 Material identification,

12.3 A statement of how the specimens were prepared and the testing conditions used; and for sheet materials the direction of testing with respect to anisotropy, if any,

12.4 The measured width and thickness of each test specimen in mm (in.),

12.5 The capacity of the pendulum in J (ft-lb),

12.6 The number of specimens tested per sample,

12.7 The number of tests per specimen,

12.8 The number of specimens with results conforming to each of the break type categories described in 4.4,

12.9 For each break type, the percentage of tests whose results fit that category followed by the break type code letter, followed by the average flatwise flexural impact values in kJ/m² (ft-lbf/in.²) for all tests falling in categories C, H, P, and N (with the exception that impact values are not to be reported for category N) (see Note 5).

NOTE 5—For example, 10 % H, 3.5 kJ/m²; 60 % P, 4.2 kJ/m²; 30 % N.

12.10 Date of testing, and

12.11 Test method number and revision date.

13. Precision and Bias

13.1 *Precision*—It is not practical to specify the precision of the procedure in this test method because the method specifies that the individual results be sorted by break type, which leads to difficulty in performing the required statistics, as a high number of materials exhibit multiple break types.

13.2 In order to provide the user with a general indication of the repeatability and reproducibility of this test method, limited repeatability and reproducibility data were generated.

13.2.1 Repeatability data were generated by one laboratory by any of approximately six operators over a one year period using a single test apparatus for 20 determinations consisting of 160 individual tests. The limited repeatability determined for this test method is as follows:

Material	Values in ft-lbf/in. ²		
	Mean	S_r^A	I_r^B
Reinforced PET plastic	17.8	0.97	2.75

^A S_r = within laboratory standard deviation.

^B I_r = repeatability interval (2.83 S_r). This is the maximum permissible difference, due to test error, between two test results obtained in a single laboratory, on the same material. The difference in absolute value will be expected to exceed the repeatability value only about 5 % of the time. Thus, if such a difference is found to be larger than the repeatability value, there is reason to question one or both of the test results.

13.2.2 Reproducibility data were generated using one material that exhibited all hinge breaks tested at three laboratories by two operators at each location. The limited reproducibility determined for this test method is as follows:

Material	Values in ft-lbf/in. ²		
	Mean	S_R^A	I_R^B
C	4.43	1.17	1.29

^A S_R = between laboratory standard deviation.

^B I_R = reproducibility interval (2.83 S_r). In comparing two test results for the same material, obtained by different operators using different equipment on different days, those test results should be judged not equivalent if they differ by more than the I_R value for that material and condition. (This applies between different laboratories or between different equipment within the same laboratory.)

13.3 *Bias*—Since there is no accepted reference material suitable for determining the bias for the procedure in this test method, bias has not been determined.

14. Keywords

14.1 aging; exposure; flexural; impact; plastic molding; plastic sheets; weathering

SUMMARY OF CHANGES

Committee D20 has identified the location of selected changes to this standard since the last issue, D6395 - 10, that may impact the use of this standard. (April 1, 2011)

(1) Revised Section 13.

Committee D20 has identified the location of selected changes to this standard since the last issue, D6395 - 05, that may impact the use of this standard. (April 1, 2010)

(1) Revised Section 9.

ASTM International takes no position respecting the validity of any patent rights asserted in connection with any item mentioned in this standard. Users of this standard are expressly advised that determination of the validity of any such patent rights, and the risk of infringement of such rights, are entirely their own responsibility.

This standard is subject to revision at any time by the responsible technical committee and must be reviewed every five years and if not revised, either reapproved or withdrawn. Your comments are invited either for revision of this standard or for additional standards and should be addressed to ASTM International Headquarters. Your comments will receive careful consideration at a meeting of the responsible technical committee, which you may attend. If you feel that your comments have not received a fair hearing you should make your views known to the ASTM Committee on Standards, at the address shown below.

This standard is copyrighted by ASTM International, 100 Barr Harbor Drive, PO Box C700, West Conshohocken, PA 19428-2959, United States. Individual reprints (single or multiple copies) of this standard may be obtained by contacting ASTM at the above address or at 610-832-9585 (phone), 610-832-9555 (fax), or service@astm.org (e-mail); or through the ASTM website (www.astm.org). Permission rights to photocopy the standard may also be secured from the Copyright Clearance Center, 222 Rosewood Drive, Danvers, MA 01923, Tel: (978) 646-2600; http://www.copyright.com/