



Standard Specification for Sulfone Plastics (SP)¹

This standard is issued under the fixed designation D6394; the number immediately following the designation indicates the year of original adoption or, in the case of revision, the year of last revision. A number in parentheses indicates the year of last reapproval. A superscript epsilon (ϵ) indicates an editorial change since the last revision or reapproval.

1. Scope*

1.1 This specification covers the classification of sulfone plastics suitable for injection molding and extrusion.

1.2 The properties included in this specification are those required to identify the compositions covered. Other requirements necessary to identify particular characteristics important to specialized applications are to be specified by using the suffixes in Section 5. See Guide D5740.

1.3 This specification is intended to be a means of calling out sulfone plastics used in the fabrication of end items or parts. Material selection can be made by those having expertise in the plastics field only after careful consideration of the design and the performance required of the part, the environment to which it will be exposed, the fabrication process to be employed, the cost involved, and the inherent properties of the material other than those covered by this specification.

1.4 Sulfone polymers, being thermoplastic, are reprocessable and recyclable. This specification allows for the use of those sulfone polymer materials, provided that any specific requirements are met.

1.5 The following safety hazards caveat pertains only to the test method portion, Section 11, of this specification: *This standard does not purport to address all of the safety concerns, if any, associated with its use. It is the responsibility of the user of this standard to establish appropriate safety and health practices and determine the applicability of regulatory limitations prior to use.*

NOTE 1—Reference Guide D7209 for information and definitions related to recycled plastics.

NOTE 2—ISO 25137 is similar in subject matter but not equivalent to this specification.

¹ This specification is under the jurisdiction of ASTM Committee D20 on Plastics and is the direct responsibility of Subcommittee D20.15 on Thermoplastic Materials.

Current edition approved April 1, 2014. Published April 2014. Originally approved in 1999. Last previous edition approved in 2011 as D6394 - 11. DOI: 10.1520/D6394-14.

2. Referenced Documents

2.1 ASTM Standards:²

- D256 Test Methods for Determining the Izod Pendulum Impact Resistance of Plastics
- D618 Practice for Conditioning Plastics for Testing
- D638 Test Method for Tensile Properties of Plastics
- D648 Test Method for Deflection Temperature of Plastics Under Flexural Load in the Edgewise Position
- D790 Test Methods for Flexural Properties of Unreinforced and Reinforced Plastics and Electrical Insulating Materials
- D792 Test Methods for Density and Specific Gravity (Relative Density) of Plastics by Displacement
- D883 Terminology Relating to Plastics
- D1238 Test Method for Melt Flow Rates of Thermoplastics by Extrusion Plastometer
- D1600 Terminology for Abbreviated Terms Relating to Plastics
- D3641 Practice for Injection Molding Test Specimens of Thermoplastic Molding and Extrusion Materials
- D3801 Test Method for Measuring the Comparative Burning Characteristics of Solid Plastics in a Vertical Position
- D3892 Practice for Packaging/Packing of Plastics
- D4000 Classification System for Specifying Plastic Materials
- D5630 Test Method for Ash Content in Plastics
- D5740 Guide for Writing Material Standards in the Classification Format
- D6869 Test Method for Coulometric and Volumetric Determination of Moisture in Plastics Using the Karl Fischer Reaction (the Reaction of Iodine with Water)
- D7209 Guide for Waste Reduction, Resource Recovery, and Use of Recycled Polymeric Materials and Products
- E29 Practice for Using Significant Digits in Test Data to

² For referenced ASTM standards, visit the ASTM website, www.astm.org, or contact ASTM Customer Service at service@astm.org. For *Annual Book of ASTM Standards* volume information, refer to the standard's Document Summary page on the ASTM website.

*A Summary of Changes section appears at the end of this standard

Determine Conformance with Specifications

2.2 Underwriters' Laboratories Standards:

UL94 Standard for Tests for Flammability of Plastic Materials³

2.3 ISO Standards:⁴

ISO 25137-1 Sulfone Polymer moulding and Extrusion Materials—Part 1: Designation System and Basis for Specification

ISO 25137-2 Sulfone Polymer Moulding and Extrusion Materials—Part 2: Preparation of Test Specimens and Determination of Properties

3. Terminology

3.1 Except for terms defined below, the terminology used in this specification is in accordance with Terminologies D883 and D1600.

3.2 Definitions of Terms Specific to This Standard:

3.2.1 sulfone plastics, *n*—plastics based on any of various aromatic polymers which contain diphenyl sulfone in the backbone of the repeating unit of the molecule.

3.2.1.1 Discussion—All of the sulfone polymers which are under this specification contain ether oxygen which is a necessary component of the polymers as in the diphenyl sulfone moiety. Examples of moieties which can be part of the backbone of the repeating unit, in addition to diphenyl sulfone, are diphenyl isopropylidene, and biphenyl. Blends of these polymers can exist as well as co- and ter-polymers. Commercial polymers that are members of this class of thermoplastics include polysulfone (SP), polyether sulfone (PESU), and polyphenylsulfone (PPSU) (see Fig. 1).

4. Classification

4.1 Unreinforced sulfone plastics are classified into groups in accordance with their composition. These groups are subdivided into classes and grades as shown in Table SP.

NOTE 3—An example of this classification system is given below. The specification SP0213 indicates the following:

³ Available from Underwriters' Laboratories (UL), 333 Pfingsten Rd., Northbrook, IL 60062-2096, <http://www.ul.com>.

⁴ Available from American National Standards Institute (ANSI), 25 W. 43rd St., 4th Floor, New York, NY 10036, <http://www.ansi.org>.

SP = sulfone plastics as defined in Section 3,
 02 (Group) = polyether sulfone, as defined in Terminology D1600,
 1 (Class) = high temperature, and
 3 (Grade) = requirements given in Table SP.

4.1.1 To facilitate incorporation of future or special materials the "Other" category for group (00), class (0), and grade (0) is shown in Table SP. The basic properties of these materials can be obtained from Table A as they apply.

4.2 Reinforced, filled, and lubricated versions of sulfone plastics that are in Table SP are classified in accordance with Tables SP and A. Table SP is used to specify the group of sulfone plastics and Table A is used to specify the property requirements after the addition of reinforcements, pigments, fillers, or lubricants at the nominal level indicated (see 4.2.1).

4.2.1 Reinforcements and Additive Materials—A symbol (single-letter) is used for the major reinforcement or combination, or both, along with two numbers which indicate the percentage of addition by mass with the tolerances tabulated as follows:

Symbol	Material	Tolerance
C	Carbon and graphite fiber reinforced	±3 %
G	Glass fiber reinforced	±3 %
L	Lubricants	Depends upon the material and process—to be specified
M	Mineral reinforced	±3 %
R	Combination of reinforcements or fillers, or both	±3 %

NOTE 4—This part of the classification system uses the percent of reinforcements or additives, or both, in the callout of the modified basic material. The types and percentages of reinforcements and additives should be shown on the supplier's technical data sheet unless they are proprietary in nature. If necessary, additional callout of these reinforcement and additives can be accomplished by use of the suffix part of the system (see Section 5).

4.2.2 Specific requirements for reinforcement, filled, or lubricated sulfone plastics shall be shown by a six-character designation. The designation will consist of the letter "A" and the five digits comprising the cell numbers for property requirements in the order as they appear in Table A.

4.2.2.1 Although the values listed are necessary to include the range of properties available in existing materials, this does not imply that every possible combination of the properties exists or can be obtained.

4.2.3 When the grade of the basic material is not known, or is not important, the "0" grade shall be used for the reinforced materials in this system.

NOTE 5—An example of this classification for a reinforced sulfone plastics material is given as follows. The specification SP0210G30A43460 would have the following material requirements:

SP0210 = poly(ether sulfone) from Table SP,
 G30 = glass reinforced at the 30 % nominal level,
 A = Table A property requirements,
 4 = tensile strength, 95 MPa min,
 3 = flexural modulus, 4.5 GPa min,
 4 = Izod impact, 50 J/m min,
 6 = deflection temperature, 200°C min, and
 0 = unspecified.

If no properties are specified, the specification would be SP0213G30A00000.

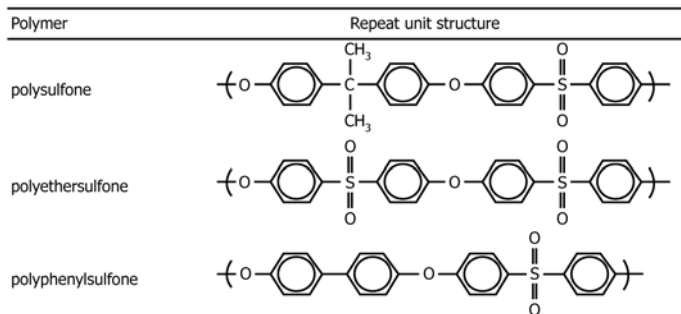

FIG. 1 Repeat Unit Structure

5. Suffixes

5.1 When additional requirements are needed for the materials covered in this specification that are not covered in Tables SP or A, then those requirements shall be designated through the use of suffixes.

5.1.1 A list of suitable suffixes are found in Table 3 of Classification **D4000**.

5.2 Flammability callouts were changed in 2007. Therefore, callouts written before 2007 are different from those written in 2007 and later.

5.2.1 If the requirements for the poly(ether sulfone) material in **4.2.3** also included flammability requirements, the following example indicates the callout based on **D4000** - 04:

SP0210G30A43460FL310

SP0210G30A43460 = same as in **4.2.3**.
 From Table 3 in Classification **D4000** - 04 the following is obtained:
 F = flammability requirements,
 L = UL94 recognition required,
 3 = 0.8 mm minimum thickness,
 1 = vertical burn test, and
 0 = V-0 rating.

5.2.2 The following example illustrates the callout based on **D4000** - 07:

SP0210G30A43460FF003

SP0210G30A43460 = same as in **4.2.3**.
 From Table 3 in Classification **D4000** - 07 the following is obtained:
 F = flammability requirements,
 F = Vertical burn rate by **D3801** or UL94V,
 0 = Rating of designation V-0,
 03 = 0.8 mm minimum specimen thickness.

6. General Requirements

6.1 Basic requirements from the property table (Table SP) or cell table (Table A) are always in effect unless superseded by specific suffix requirements, which always take precedence. Properties in Table A supersede properties in Table SP.

6.2 The plastics composition shall be uniform and shall conform to the requirements specified herein.

7. Detail Requirements

7.1 The materials shall conform to the respective requirements of Tables SP, A, and the suffix as they apply.

7.2 For purposes of determining conformance, all specified limits for a specification (line callout) based on this classification system are absolute limits, as defined in Practice **E29**.

7.2.1 With the absolute method, an observed value or a calculated value is not rounded, but is to be compared directly with the limiting value. Conformance or nonconformance is based on this comparison.

8. Sampling

8.1 Sampling shall be statistically adequate to satisfy the requirements of **12.4**.

8.2 A batch or lot shall be defined as a unit of manufacture as prepared for shipment and is permitted to consist of a blend of two or more production runs.

9. Specimen Preparation

9.1 The test specimens shall be prepared by injection molding process in accordance with Practice **D3641**. Recommended processing conditions are shown in Table 1.

9.2 Before molding, the material shall be dried to a moisture level of no more than 0.05 % as determined by test methods described in Test Method **D6869**.

10. Conditioning

10.1 Test specimens shall be conditioned in the standard laboratory atmosphere in accordance with Procedure A of Practice **D618** for a minimum of 4 h before performing the required tests.

10.2 Conduct those tests influenced by ambient conditions in the standard laboratory atmosphere of $23 \pm 2^\circ\text{C}$ and $50 \pm 10\%$ relative humidity.

11. Test Methods

11.1 Determine the properties enumerated in this specification by means of Test Methods **D256**, **D638**, **D648**, **D790**, **D792**, **D1238**, and **D5630**.

11.1.1 The number of tests shall be consistent with the requirements of Section 8 and **12.4**.

11.1.2 All test specimens shall be 3.2 by 12.7 mm, unless otherwise specified.

11.1.3 *Flow Rate*—In accordance with Test Method **D1238**, using the following conditions:

11.1.3.1 *SP*— 343°C and 2.16 Kg load,

11.1.3.2 *PESU*— 380°C and 2.16 Kg load, or 360°C and 10 Kg load,

11.1.3.3 *PPSU*— 365°C and 5.00 Kg load, and

11.1.3.4 *PPSU/SP Blends*— 380°C and 2.16 Kg load

11.1.4 *Deflection Temperature (Test Method D648)*—Test specimens shall be annealed for 1 h in an air circulating oven at the following temperatures:

11.1.4.1 *SP* at 170°C , and

11.1.4.2 *PESU*, *PPSU*, and *PPSU/SP blends* at 200°C .

11.1.5 *Izod Impact (Test Method D256)*—Test the center portion of a 100-mm specimen which is 3.2 mm wide by 12.7 mm deep.

12. Inspection and Certification

12.1 Certification of the material supplied with reference to a specification based on this specification shall be for conformance to the requirements specified herein.

12.2 Lot acceptance inspection shall be the basis on which acceptance or rejection of the lot is made. The lot acceptance inspection shall consist of the following:

	Unfilled Polymer	Reinforced Polymer	Unfilled Blend	Reinforced Blend
Flow Rate, g/10 min (Test Method D1238)	Yes	No	Yes	No
Ash, % (Test Method D5630)	No	Yes	No	Yes

NOTE 6—The term *blend* implies a blend of two or more SPs.

NOTE 7—For flow rate measurement, moisture content of the material must not exceed 0.03 percent.

12.3 Periodic check inspection with reference to a specification based upon this specification shall consist of the tests for all requirements of the material under the specification. Inspection frequency shall be adequate to ensure the material is certifiable in accordance with 12.4.

12.4 Certification shall be that the material was manufactured by a process in statistical control, sampled, tested, and inspected in accordance with this specification and that the average values for the lot meet the requirements of the specification (line callout).

NOTE 8—The ASTM publication, *Manual on Presentation of Data and Control chart Analysis, 7th Edition*, Stock Number MNL7A, provides

detailed information about statistical process control.

12.5 A report of test results shall be furnished when requested. The report shall consist of results of the lot acceptance inspection for the shipment, and when requested, the results of the most recent periodic check inspection.

13. Packaging, Packing, and Marking

13.1 The provisions of Practice D3892 apply to packaging, packing, and marking of containers for plastics materials.

14. Keywords

14.1 line callout; plastics materials; polyethersulfone; polyphenylsulfone; polysulfone; recycled

TABLE SP Requirements for Unreinforced Sulfone Plastics

Group	Description	Class	Description	Grade	Description	Flow Rate, ^A g/10	Deflection Temperature, ^B °C, min.	Tensile Strength, ^C MPa, min.	Flexural Modulus, ^D MPa, min.	Izod Impact, ^E J/m, min.	Specific Gravity, ^F min.
01	Polysulfone	1	General Purpose	1		2.0 ≤ 5.0	170	68	2500	30	1.23
				2		>5.0 ≤ 9.0	170	68	2500	30	1.23
				3		>9.0 ≤ 15.0	170	68	2500	30	1.23
				4		>15.0 ≤ 20.0	170	68	2500	30	1.23
				5		>20.0 ≤ 27.0	170	68	2500	30	1.23
0	Other										
02	Poly(ether sulfone)	1	High Temperature	1		9.5 ≤ 15.0	200	79	2600	50	1.36
				2		>15.0 ≤ 25.0	200	79	2600	50	1.36
				3		>25.0 ≤ 35.0	200	79	2600	50	1.36
0	Other										
03	Poly(phenyl sulfone)	1	High Temperature, Tough	1		9.0 ≤ 17.0	200	68	2200	500	1.28
				2		>13.0 ≤ 20.0	200	68	2200	500	1.28
				3		>20.0 ≤ 28.0	200	68	2200	500	1.28
				4		>28.0 ≤ 36.0	200	68	2200	500	1.28
0	Other										
04	Sulfone Polymer Blends	1	PPSU/SP Blends	1		14.0 ≤ 20.0	195	68	2200	275	1.27
				2		9.0 ≤ 15.0	190	68	2200	80	1.26
0	Other										
00	Other	0	Other	0	Other						

^AFlow rate Test Method D1238, conditions: SP: 343°C/2.16 kg; PESU: 380°C/2.16 kg; PPSU: 365°C/5.0 kg; PPSU/SP Blends: 380°C/2.16 kg and moisture content of the material must not exceed 0.03 percent.

^BDeflection temperature Test Method D648, conditions: 1.8 MPa. Use 3.2-mm thick specimens annealed in accordance with Section 11.

^CTensile strength Test Method D638, Type I tensile bar, rate of crosshead motion: 50 mm/min.

^DFlexural modulus Test Method D790, specimen 3.2 by 12.7 mm cross section, rate of crosshead motion: 1.3 mm/min.

^EIzod impact Test Method D256, test center portion of 100-mm long specimens with nominal dimensions of 3.2 by 12.7 mm.

^FSpecific gravity Test Method D792.

TABLE A Detailed Requirements of Reinforced Sulfone Plastics

Designation or Order Number	Property	0	1	2	3	4	5	6	7	8	9
1	Tensile strength, ^A D638, min, MPa ^B	unspecified	50	65	80	95	110	130	150	170	specify value
2	Flexural modulus, ^C D790 (A), min, GPa ^B	unspecified	2.5	3.5	4.5	5.5	7.0	9.0	10.0	12.0	specify value
3	Izod impact resistance, ^D D256, min, J/m ^E	unspecified	20	30	40	50	70	90	120	150	specify value
4	Deflection temperature at 1.8 MPa, ^F D648, min, °C	unspecified	150	160	170	180	190	200	210	220	specify value
5	To be determined	unspecified

^AType I D638 test specimens, tested at 5 mm/min.

^BMPa × 145 = psi.

^CTest specimens are nominal 3.2 mm in depth by 12.7 mm wide. Span is a nominal 50 mm. Rate of crosshead is 0.05 mm/min using method 1.

^DTest specimens are nominal 3.2 mm wide with a depth of 12.7 mm.

^EJ/m × (1.873 × 10⁻²) = ft lb/in. or ft lb/in. × 53.38 = J/m.

^FTest specimens are nominal 3.2 mm deep by 12.7 mm wide.

TABLE 1 Recommended Processing Conditions

Polymer	Melt Temperature, °C	Mold Temperature, °C	Velocity, mm/s
SP	345-390	100-160	200 ± 100
PESU	345-385	130-170	200 ± 100
PPSU	360-390	140-180	200 ± 100
PPSU/SP Blends	360-390	130-170	200 ± 100

SUPPLEMENTARY REQUIREMENTS

FOR SPECIAL END USES

The following supplementary requirements shall apply only when specified by the inquiry, contract, or order for agencies of the U.S. Government.

Special End Uses of Polysulfone (SP) Plastics

S1.1 Unless otherwise specified in the contract or purchase order, the supplier is responsible for the performance of acceptance testing in accordance with 12.2 of this specification. Except as otherwise specified, the supplier shall utilize its own facilities or any commercial laboratory acceptable to the U.S. Government. The U.S. Government reserves the right to

perform any of the testing or inspections set forth in the specification requirements.

Physical Requirements for Polysulfone (SP) Plastics

S2.1 Material properties, in addition to those in Tables SP and A, if required for initial material qualifications (such as those described in MIL-P-46120B) are given in Table S.

TABLE S MIL-P-46120B Requirements

Properties	1		2		3		4		5		6	
	Type I Unreinforced		Type II (Glass Fiber Reinforced)		Class 1 (10 % GFR)		Class 2 (20 % GFR)		Class 3 (30 % GFR)		Class 4 (40 % GFR)	
	Class 1 Molding	Class 2 Extrusion										
Mechanical/Physical												
Specific gravity at 23°C, D792	1.23-1.25	1.23-1.25	1.33 ± 0.02		1.40 ± 0.02		1.49 ± 0.02		1.57 ± 0.02			
Izod impact at 23°C, 3 mm (1/8 in.) specimen, J/m (ft-lb/in.) notched, D256	53 (1.0)	53 (1.0)	48 (0.9)		53 (1.0)		58 (1.1)		64 (1.2)			
Mold shrinkage, m/m, D955	0.007	0.007	0.004		0.003-0.004		0.002-0.003		0.0015-0.002			
Tensile elongation at break, % min, D638	20	20	4		3		2		1.7			
Tensile strength at yield, MPa (psi), min, D638	65 (9500)	65 (9500)	73 (10 500)		90 (13 000)		96 (14 000)		110 (16 000)			
Water Absorption, 24 h, % max, D570	0.35	0.35	0.50		0.50		0.50		0.50			
Thermal												
Coefficient of linear thermal expansion, in./in.°F, D696	3.1 × 10 ⁻⁵	3.1 × 10 ⁻⁵	2.5 × 10 ⁻⁵		1.7 × 10 ⁻⁵		1.4 × 10 ⁻⁵		1.2 × 10 ⁻⁵			
Heat distortion temperature at 1820 kPa (264 psi), unannealed, °C (°F), min D648	168 (335)	168 (335)	176 (350)		176 (350)		179 (355)		182 (360)			
Melt flow rate at 343°C (650°F), 298 kPa (43 psi), g/10 min, D1238	4.5-9.0	2.0-4.5			
Flammability, UL 94, D3801	V-0	V-0	V-0		V-0		V-0		V-0			
Electrical												
Dielectric constant, at 1 MHz, max, D150	3.2	3.2	3.4		3.5		3.5		3.5			
Dissipation factor at 1 MHz, max, D150	0.006	0.006	0.005		0.005		0.005		0.005			
Dielectric strength, 3 mm (1/8 in.) specimen, volts per mil, min, D149	350	350	480		480		480		480			

Quality Assurance for Polysulfone (SP) Plastics

S3.1 *Acceptance Criteria*—For the purpose of these supplementary requirements only, the lot acceptance tests shall consist of tests for specific gravity, melt flow rate (for unreinforced materials only), and heat deflection temperature.

S3.2 *Sample Size*—The minimum number of test specimens to be tested shall conform with the requirements of the respective test method or, if different, by agreement with the customer.

S3.3 *Test Methods*—Testing shall be in accordance with the methods specified in Table SP, A, and S.

S3.4 *Conditioning*—Test specimens shall be conditioned as described in Section 10 if this specification.

S3.5 *Lot Certification*—Lot certification shall be in accordance with 12.4 of this specification.

APPENDIX

(Nonmandatory Information)

X1. CROSS REFERENCE TO MIL-P-46120B

X1.1 See Table below

X1.1.1

D6394	MIL-P-46120B
SP0110S1	Type I Class 1
SP0110S2	Type I Class 2
SP0110G10S3	Type II Class 1
SP0110G20S4	Type II Class 2
SP0110G30S5	Type II Class 3
SP0110G40S6	Type II Class 4

Explanation of the callout using the supplemental requirements: SP0110S1

SP = Table SP

011 = General purpose polysulfone

0 = Unspecified grade

S = Table S

I = Unreinforced molding material having properties as specified in column 1 of Table S

SP0110G30S5

SP = Table SP

011 = General purpose polysulfone

0 = Unspecified grade

G30 = Glass reinforced at the 30% nominal level

S = Table S

5 = Glass fiber reinforced SP having properties as specified in column 5 of Table S

SUMMARY OF CHANGES

Committee D20 has identified the location of selected changes to this standard since the last issue (D6394 - 11) that may impact the use of this standard. (April 1, 2014)

(1) Revised Table SP: Changed the minimum MFR for Group 3, Class 1, Grade 2 from >14.0 to >13.0.

ASTM International takes no position respecting the validity of any patent rights asserted in connection with any item mentioned in this standard. Users of this standard are expressly advised that determination of the validity of any such patent rights, and the risk of infringement of such rights, are entirely their own responsibility.

This standard is subject to revision at any time by the responsible technical committee and must be reviewed every five years and if not revised, either reapproved or withdrawn. Your comments are invited either for revision of this standard or for additional standards and should be addressed to ASTM International Headquarters. Your comments will receive careful consideration at a meeting of the responsible technical committee, which you may attend. If you feel that your comments have not received a fair hearing you should make your views known to the ASTM Committee on Standards, at the address shown below.

This standard is copyrighted by ASTM International, 100 Barr Harbor Drive, PO Box C700, West Conshohocken, PA 19428-2959, United States. Individual reprints (single or multiple copies) of this standard may be obtained by contacting ASTM at the above address or at 610-832-9585 (phone), 610-832-9555 (fax), or service@astm.org (e-mail); or through the ASTM website (www.astm.org). Permission rights to photocopy the standard may also be secured from the Copyright Clearance Center, 222 Rosewood Drive, Danvers, MA 01923, Tel: (978) 646-2600; http://www.copyright.com/