



# Standard Practice for Design, Testing, and Construction of Microsurfacing<sup>1</sup>

This standard is issued under the fixed designation D6372; the number immediately following the designation indicates the year of original adoption or, in the case of revision, the year of last revision. A number in parentheses indicates the year of last reappraisal. A superscript epsilon ( $\epsilon$ ) indicates an editorial change since the last revision or reappraisal.

## 1. Scope

1.1 This practice covers the design, testing, and construction of mixtures of polymer modified asphalt emulsion, mineral aggregate, mineral filler, water, and other additives, properly proportioned, mixed and spread on a paved surface. It is written as a guide and should be used as such. End use specifications should be adapted to conform to job and user requirements.

NOTE 1—This practice references test methods outside the jurisdiction of ASTM that may or may not have a precision statement.

1.2 The values stated in SI units are to be regarded as the standard.

1.3 *This standard does not purport to address all of the safety concerns, if any, associated with its use. It is the responsibility of the user of this standard to establish appropriate safety and health practices and determine the applicability of regulatory limitations prior to use.*

## 2. Referenced Documents

### 2.1 ASTM Standards:<sup>2</sup>

- C88 Test Method for Soundness of Aggregates by Use of Sodium Sulfate or Magnesium Sulfate
- C131 Test Method for Resistance to Degradation of Small-Size Coarse Aggregate by Abrasion and Impact in the Los Angeles Machine
- D2397 Specification for Cationic Emulsified Asphalt
- D2419 Test Method for Sand Equivalent Value of Soils and Fine Aggregate
- D3910 Practices for Design, Testing, and Construction of Slurry Seal
- E145 Specification for Gravity-Convection and Forced-Ventilation Ovens

<sup>1</sup> This practice is under the jurisdiction of ASTM Committee D04 on Road and Paving Materials and is the direct responsibility of Subcommittee D04.24 on Asphalt Surface Treatments.

Current edition approved June 15, 2015. Published August 2015. Originally approved in 1999. Last previous edition approved in 2010 as D6372 – 05 (2010). DOI: 10.1520/D6372-15.

<sup>2</sup> For referenced ASTM standards, visit the ASTM website, [www.astm.org](http://www.astm.org), or contact ASTM Customer Service at [service@astm.org](mailto:service@astm.org). For *Annual Book of ASTM Standards* volume information, refer to the standard's Document Summary page on the ASTM website.

### 2.2 ISSA Documents:

- ISSA Technical Bulletin No. 100, Test Method for Wet Track Abrasion of Slurry Surfaces<sup>3</sup>
- ISSA Technical Bulletin No. 109, Test Method for Measurement of Excess Asphalt in Bituminous Mixtures by Use of a Loaded Wheel Tester and Sand Adhesion
- ISSA Technical Bulletin No. 139, Test Method to Classify Emulsified Asphalt/Aggregate Mixture Systems by Modified Cohesion Tester, Measurement of Set and Cure Characteristics<sup>3</sup>
- ISSA A143 Revised May 2003 Recommended Performance Guidelines For Micro-Surfacing<sup>3</sup>
- ISSA Technical Bulletin No. 144, Test Method for Classification of Aggregate Filler—Bitumen Compatibility by Schultze-Breuer and Ruck Procedures
- ISSA Technical Bulletin No. 147, Test Methods for Measurements of Stability and Resistance to Compaction, Vertical and Lateral Displacement of Multilayered Fine Aggregate Cold Mixes<sup>3</sup>

## 3. Terminology

### 3.1 Definitions of Terms Specific to This Standard:

3.1.1 *polymer modified emulsified asphalt micro surfacing mixtures*—as related to this practice, mixtures of fine aggregate with mineral filler, mixing water, and field control additive, uniformly mixed with polymer modified emulsified asphalt.

## 4. Summary of Practice

4.1 This practice outlines the basic properties for materials, mix design procedures, and application techniques for the design and application of microsurfacing. The mix developed through this practice should be capable of being spread in variable thick cross sections, which after curing and initial traffic consolidation, resist compaction through the entire design tolerance range of bitumen content and variable thickness to be encountered. The end product should maintain a high friction surface and variable thick sections throughout its surface life. The mix should be a quick traffic system and should be able to accept rolling traffic on a 12.7 mm thick surface within 1 h after placement in 24°C temperature and 50 % or less humidity.

<sup>3</sup> Available from International Slurry Surfacing Association, 3 Church Circle, PMB 250, Annapolis, MD 21401.

**5. Significance and Use**

5.1 This microsurfacing practice is written as a guide and should not be construed as a specification. End use specifications should be adapted to conform to job and user requirements.

**6. Design**

6.1 *Aggregates*—The aggregate shall be a manufactured crushed stone such as granite, slag, limestone, chat, or other high quality aggregate or combination thereof. The aggregate shall be totally crushed with 100 % of the parent aggregate being larger than the largest stone in the gradation to be used. Recommended grading requirements are shown in **Table 1**. When tested by Test Method **D2419**, the combined aggregate prior to the addition of any chemically active mineral filler shall have a sand equivalent of not less than 65. When tested by Test Method **C88** the aggregate shall have a weighed average loss not greater than 15 % using sodium sulfate or 25 % using magnesium sulfate. Testing by Test Method **C131** shall show an abrasion resistance of 30 % maximum.

6.2 *Mineral Filler*—Mineral filler shall be any recognized brand of nonairentrained portland cement or hydrated lime. The mineral filler shall be free of lumps and accepted upon visual inspection. The type and amount of mineral filler needed shall be determined by a laboratory mix design and will be considered as part of the aggregate gradation.

6.3 *Emulsified Asphalt*—The emulsified asphalt shall be a quick set polymer modified asphalt emulsion conforming to the requirements of Specification **D2397** for CSS-1h. The polymer material shall be milled or blended into the asphalt or emulsifier solution prior to the emulsification process. The cement mixing test shall be waived for this emulsion. The five day settlement test may be waived. Refer to ISSA Document A143.

**7. Composition of Microsurfacing Mixtures**

7.1 A job mixture shall be selected that conforms to the specifications for a quick traffic system, meaning that it will be able to accept traffic after a short period of time and is capable of being spread in variable cross sections, wedges, ruts, scratch courses, and surfaces and that after curing and initial traffic consolidation resists compaction throughout the entire design tolerance range of bitumen content and variable thickness to be encountered. The mixture should maintain a high friction surface, and variable thick sections throughout the service life of the mixture. The mixture shall be able to accept rolling traffic on a 12.7 mm thick surface within 1 h after placement at

24°C temperature and 50 % or less humidity. The mixture shall conform to one of the gradation types listed in **Table 1**. Type II is suitable for urban and residential streets and airport runways. It shall be applied at the minimum rate of 5.4 to 8.1 kg/m<sup>2</sup>. Type III is suitable for primary and interstate routes and to fill wheel ruts. It shall be applied at the rate of 8.1 to 16.2 kg/m<sup>2</sup> for primary and interstate routes. The application for wheel ruts shall be as prescribed in **Appendix X1**.

**8. Test Procedures For Mix Design of Polymer Modified Emulsified Asphalt Microsurfacing Systems**

8.1 *Cohesion Test:*

8.1.1 This test procedure is used to determine various set times of the microsurfacing mixture. It measures torque of a microsurfacing mixture as it coalesces and develops cohesive strength. The amount of torque developed plotted over time shows how the mixture is developing resistance to movement. Specific torque and time values are defined as “set time” and “early rolling traffic time” (see **Fig. 1**).

8.1.2 Set time is defined as the lapsed time after casting a specimen of the microsurfacing mixture after which it cannot be remixed homogeneously (there is no free emulsion to lubricate the system) and no lateral displacement is possible when it is compacted. It is further defined as the time when there are no signs of free emulsion when pressed with an absorptive paper towel and there is no free emulsion diluted and washed away when rinsed with water.

8.1.3 Early rolling traffic time is defined as the time at which the microsurfacing mixture will accept rolling traffic without picking or deformation.

8.1.4 Set times for the microsurfacing mixture shall be determined as outlined in 6.3 of Practice **D3910**.

NOTE 2—Referenced ISSA Technical Bulletin No. 139.

8.2 *Wet Track Abrasion Test:*

8.2.1 This test procedure is used to determine the minimum asphalt content and resistance to abrasion.

**TABLE 1 Grading Requirements**

Sieve Size	Type II Percent Passing	Type III Percent Passing	Stockpile Tolerance
9.5 mm	100	100	
4.75 mm	90 to 100	70 to 90	± 5 %
2.36 mm	65 to 90	45 to 70	± 5 %
1.18 mm	45 to 70	28 to 50	± 5 %
600 µm	30 to 50	19 to 34	± 5 %
330 µm	18 to 30	12 to 25	± 4 %
150 µm	10 to 21	7 to 18	± 3 %
75 µm	5 to 15	5 to 15	± 2 %

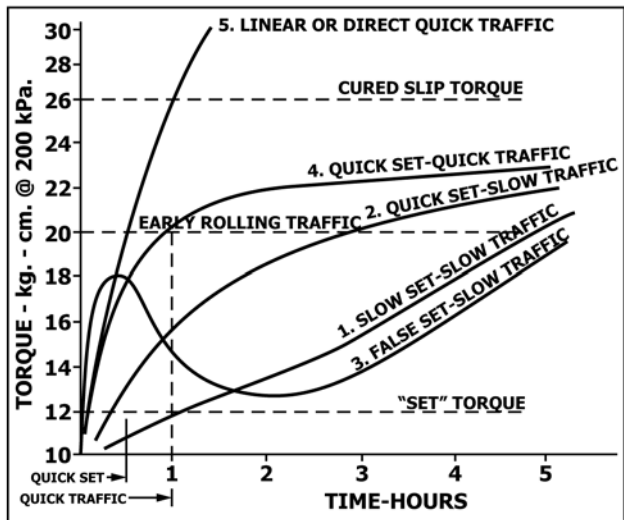

**FIG. 1 Classification of Mix Systems by Modified Cohesion Test Curves**

8.2.2 It establishes the minimum permissible emulsion content of a given microsurfacing system and the long term moisture susceptibility of the system.

8.2.3 The test shall be run in accordance with Practice D3910, Section 6.4.

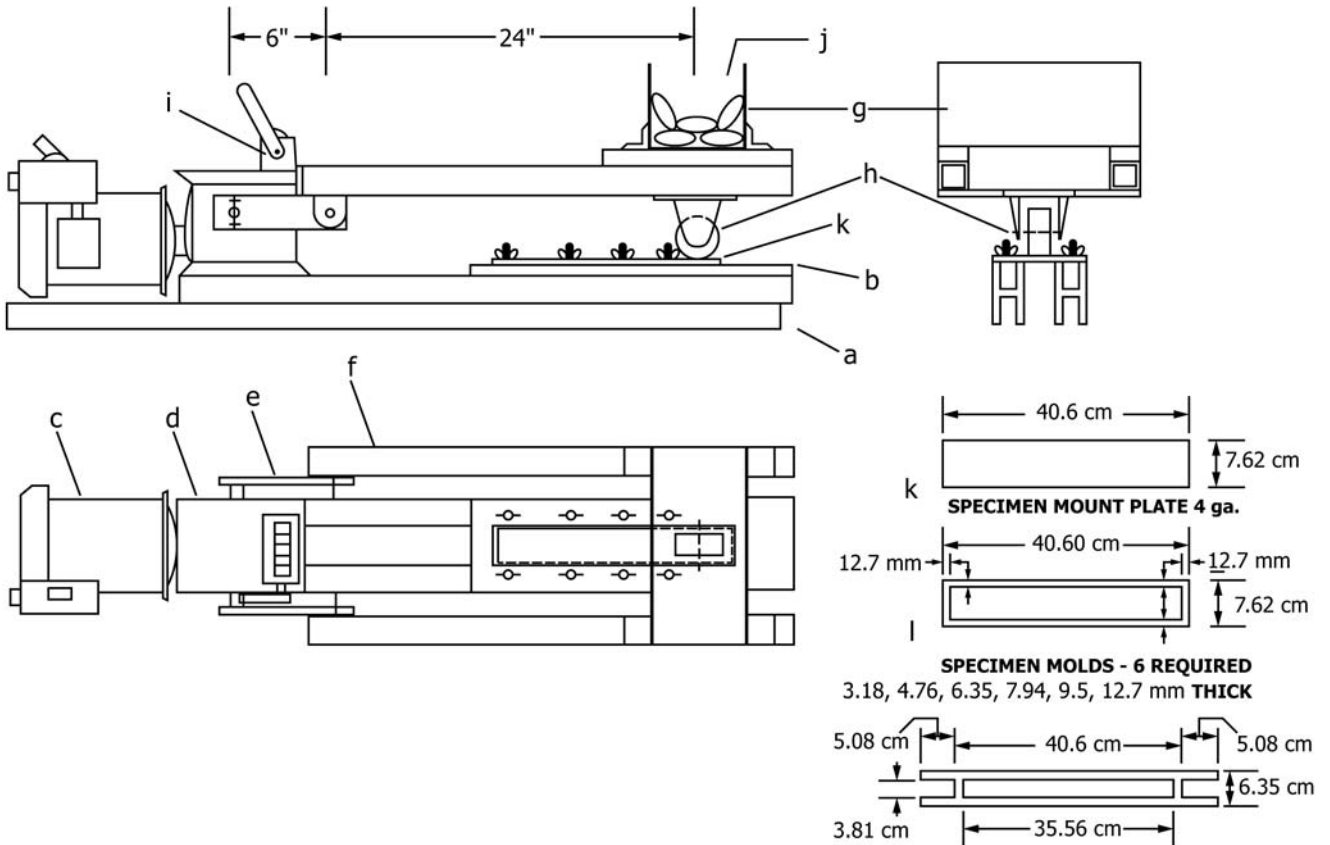
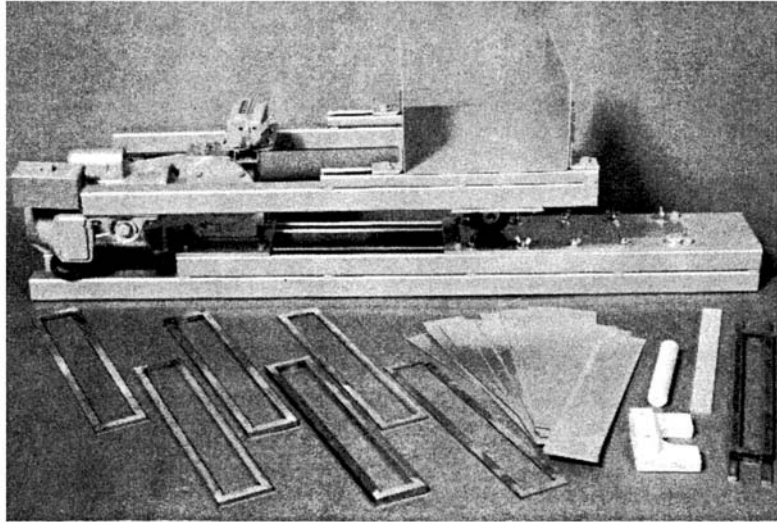

FIG. 2 Loaded Wheel Tester

8.3 *Loaded Wheel Test*—This test procedure measures the amount of compaction and displacement characteristics of multi-layered microsurfacing mixtures under simulated rolling traffic compaction (see Fig. 2).

8.3.1 *Summary of Test Procedure:*

8.3.1.1 A 500 g dry aggregate weight mixture is prepared using 0/#4 or other gradation aggregate and the desired quantities of fillers, water, additives, and asphalt emulsion. After 30 s of vigorous mixing, the mixture is cast into 12.7 by 50.8 mm by 38.1 cm mold centered over a 0.60 mm mounting plate and immediately struck-off uniformly with a wooden dowel or U shaped wooden screed using a sawing action. The inside surfaces of the mold may be coated with a thin coating of petroleum jelly or a mixture of glycerin and talc as a mold release to prevent sticking.

8.3.1.2 As soon as the mixture is sufficiently set to prevent free flow, the mold is carefully removed without disturbing the specimen. The specimen is air cured for 24 h, then dried to a constant weight in a forced draft oven at 60°C for 18 to 20 h. After cooling, the specimen is measured centrally for width and net thickness. The net weight of the specimen is obtained and recorded. The specimen is then mounted in the loaded wheel track machine and subjected to 1000, 56.7 kg cycles of compaction. The specimen is then removed and immediately remeasured laterally in the wheel path and the results recorded. The lateral displacement is expressed as the percent increase of the original width. The specific gravity should be expressed as the increase by percent after compaction of the specimen.

8.3.2 *Apparatus:*

8.3.2.1 *Balance*, capable of weighing 2000 g or more to within  $\pm 1.0$  g.

8.3.2.2 *Loaded Wheel Tester*, (as described in ISSA TB109) consisting of a 7.62 cm diameter soft rubber wheel loaded with 56.7 kg which reciprocates through a 30.48 cm horizontal path at the rate of 44 cycles per minute.

8.3.2.3 *Suitable Heavy Gage Round Bottom Bowl*, suitable to prepare 500 gram mixes.

8.3.2.4 *Long Handled Steel Spoon*, or suitable spatula for mixing of aggregate emulsion mixtures.

8.3.2.5 *Specimen Mounting Plate*, (0.60 mm galvanized steel 7.62 by 40.6 cm, deburred).

8.3.2.6 *Specimen Mold*, 12.7 mm thick by 76.2 mm  $\times$  40.6 cm outside and 50.8 mm by 38.1 cm inside dimensions.

8.3.2.7 *Calipers*, capable of measuring specimen width to within 0.01 mm.

8.3.2.8 *Oven*, forced draft constant temperature thermostatically controlled at  $60 \pm 3^\circ\text{C}$ . See specification E145 Type IIB.

8.3.3 *Preparation of Test Specimen:*

8.3.3.1 A 500 gram dry weight aggregate mixture is prepared using the 4.75 mm and smaller fractions, the desired quantities of fillers, water additives, and asphalt emulsion.

8.3.3.2 After 30 s of vigorous mixing, cast the mixture into the mold, centered over the 0.60 mm mounting plate and immediately struck-off uniformly with a wooden dowel or U shaped wooden screed using a sawing action. The casting operation should be completed within 15 s so that no more than 45 s has elapsed from starting the mix to finishing the specimen.

8.3.3.3 As soon as the mixture is sufficiently set to prevent free flow, carefully remove the mold without disturbing the specimen. Then air-cure the specimen for 24 h and then dry to a constant weight in a forced draft oven at 60°C for 18 to 20 h.

8.3.3.4 After cooling for 2 h to room temperature, measure the specimen with the calipers for net lateral thickness.

8.3.3.5 Then mount the specimen in the loaded wheel tester machine and subject it to 1000 cycles of compaction at a temperature of  $22 \pm 2^\circ\text{C}$ .

8.3.3.6 Then remove the specimen from the loaded wheel tester machine and immediately remeasure laterally.

8.3.3.7 Reference Document ISSA Technical Bulletin No. 147.

8.4 *Classification Test*—This test procedure covers the determination of the relative compatibility between aggregate filler of specific gradation and emulsified asphalt residue.

8.4.1 *Summary of Test Procedure*—The test procedure provides a rating system or grading values for abrasion loss, adhesion, and high temperature cohesion characteristics of a specified aggregate-bitumen combination for comparison with test values of referenced combinations.

8.4.2 *Apparatus:*

8.4.2.1 *Balance*, capable of weighing 1000 g sensitive to  $0.01 \pm 0.005$  g.

8.4.2.2 *Oven*, forced draft constant temperature thermostatically controlled at  $60 \pm 3^\circ\text{C}$ . See Specification E145 Type IIB.

8.4.2.3 *Suitable Heavy Gage Round Bottom Bowl*, to contain 200 g of mixture.

8.4.2.4 *Suitable Mixing Spatula*, or long handled metal spoon.

8.4.2.5 *Metal Pill Mold*, consisting of a base, a case 30 mm inside diameter by 70 mm height and a 29 mm diameter ram.

8.4.2.6 *Constant Force Press*, capable of exerting a constant force of 1000 kg.

8.4.2.7 *Shuttle Cylinders*, consisting of acrylic tubes 60 mm inside diameter by 400 mm inside length containing  $1100 \pm 25$  mm. Volume enclosed with water tight metal caps at each end, one of which is readily removable.

8.4.2.8 *Abrasion Machine*, capable of holding at least two pairs of shuttle cylinders and rotating them end for end about a central axis at 20 rpm (see Fig. 3).

8.4.2.9 *Open Top 6 mm Galvanized Hardware Cloth Baskets*, 50 mm diameter by 50 mm high with suitable means for suspension in boiling water.

8.4.2.10 *Hot Plate*, capable of heating 500 ml of water to boiling.

8.4.2.11 *800 ml Metal or Glass Beaker*, capable of holding boiling water.

8.4.3 *Preparation of Test Specimen:*

8.4.3.1 The aggregate to be used shall be dry sieved and regraded as prescribed (see Table 2).

8.4.3.2 Weigh into the mixing bowl 200 g of the prepared aggregate, 2 g Type I portland cement or the desired amount of cement or other additives, or both, and sufficient water to produce a workable mix (about 50 g). Premix thoroughly before adding the emulsion.

8.4.3.3 Add the equivalent of  $8.125 \pm 0.1\%$  pure bitumen (12.5 of a 65 % residue emulsified asphalt) and mix until



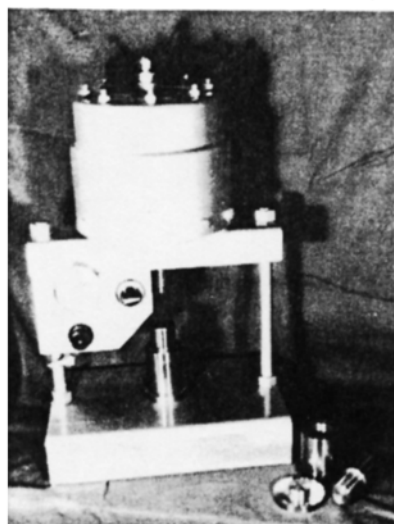
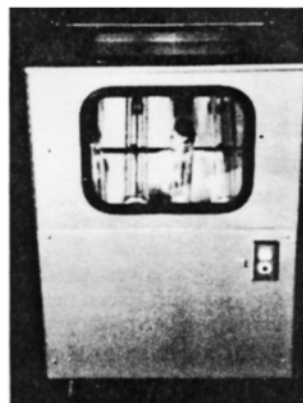
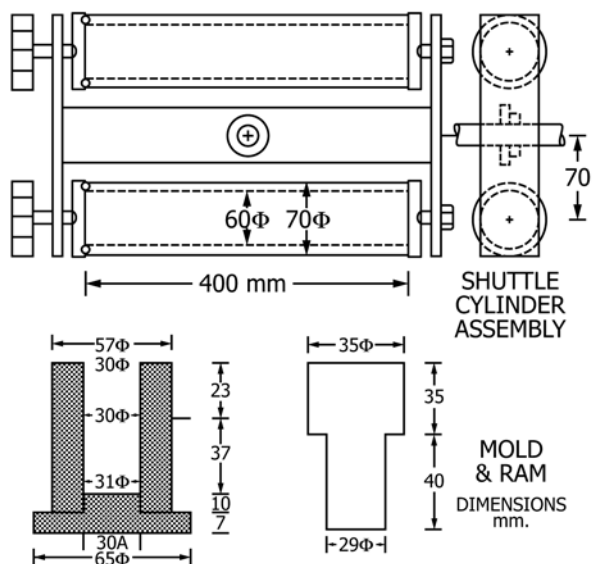

Constant Force Pill Press and Molds

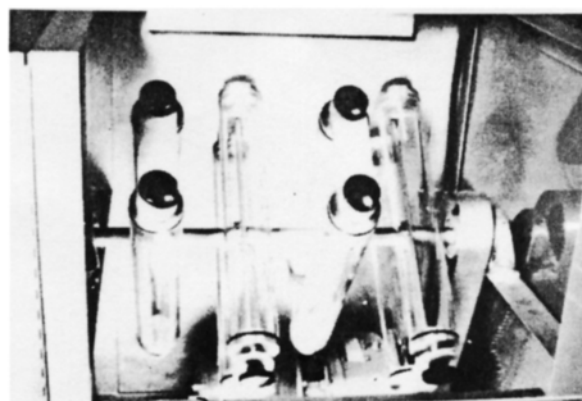

Above: Safety Cabinet Closed  
Below: Shuttle Cylinder Assembly

FIG. 3 Schulze-Breuer Abrasion Machine

TABLE 2 Dry Sieve Measurements for Aggregate

Metric Sieve	%
710 to 2.00 mm	= 25 %
250 to 710 μm	= 40 %
90 to 250 μm	= 15 %
90 to 0.0 μm	= 20 %

broken. Place the crumbed mixture into a suitable drying pan and air cure for minimum of 1 h. Dry in a forced draft 60°C oven to a constant weight.

8.4.3.4 Place 40 g ± one g of the dried crumbed mixture into the steel mold which is preheated to 60°C. Immediately press the mix for 1 min at a pressure of 1000 kg. Remove the resulting pill from the mold and cool to room temperature.

8.4.3.5 Remove any loose flashing from the pill and weigh to the nearest 0.01 g.

8.4.3.6 Submerge the pill in a 25 ± 5°C water bath for six days.

8.4.3.7 After soaking for six days, remove the pill from the water bath and surface dry by blotting with a hard surface paper towel until no wet spots appear on the towel.

8.4.3.8 Weigh the surface dried specimen to the nearest 0.01 g.

8.4.3.9 Fill the shuttle cylinder with tap water to 750 ± 25 mL (2/3 full), place the pill in the cylinder, replace the removable end to close the cylinder and place securely in the abrasion machine. Run the abrasion machine for 3 h ± 3 min at 20 rpm (3600 cycles). Upon completion, remove the pill

from the shuttle cylinder and surface dry the abraded pill as before. Immediately weigh to the nearest 0.01 g.

8.4.3.10 Place the abraded pill in the hardware cloth basket and suspend in a 800 mL beaker or other suitable container full of vigorous boiling water. Boil the pill for 30 min. Remove the pill in the hardware cloth basket from the boiling water and place the remains of the boiled pill on an absorbent paper towel. When surface dry, weigh the largest remaining coherent mass and record. Calculate the weight as percent of the original saturated pill. After air drying for 24 h estimate the percent of aggregate filler particles that are completely coated with bitumen. A report of the average results of quadruplet specimens to include: absorption in grams absorbed, abrasion loss in grams lost, adhesion and percent coated, and integrity in percent retained mass. Grade the results by comparing to the values in **Table 3**. See ISSA Technical Bulletin No. 144.

## 9. Microsurfacing Construction

9.1 The work covered by this procedure consists of furnishing all labor, equipment and materials and performing all operations necessary in connection with the proper application of a microsurfacing system upon the designated surface.

9.2 *Equipment*—All equipment, tools and machines used to perform this work shall be maintained in satisfactory working order at all times.

9.2.1 *Microsurfacing Machine*—The machine shall be specifically designed and manufactured to lay microsurfacing. The machine shall be a self-propelled, continuous flow mixing unit, able to accurately deliver and proportion the aggregate, emulsified asphalt, mineral filler, control setting additive, and water to a revolving multi-blade double shafted mixer and discharge the mixed product on a continuous flow basis. The machine shall have sufficient storage capacity for aggregate, emulsified asphalt, mineral filler, control additive and water to maintain an adequate supply to the proportioning controls. On major highway work, the machine may be required to be a self loading machine capable of loading materials while continuing to lay microsurfacing. The self loading machine shall be equipped to allow the operator to have full control of the forward and reverse speed during application of the microsurfacing material and be equipped with opposite side drivers stationed to assist in alignment. The self loading device, opposite side drivers stations, and forward and reverse speed controls shall be original equipment manufacturer designed.

9.2.1.1 Individual volume or weight controls for proportioning each material and used in material calibration shall be provided and properly marked.

9.2.1.2 The machine shall include a surfacing box with twin shafted paddles or spiral augers fixed in the spreader box. A front seal shall be provided to ensure no loss of mixture at the

road contact point. The rear shall act as a final strike-off and shall be adjustable. The spreader box and rear strike-off shall be so designed and operated that a uniform consistency is achieved to produce a free flow of material to the rear strike-off. The box shall have suitable means provided to side-shift the box to compensate for variations of pavement geometry. A secondary strike-off shall be provided to improve surface texture. It shall have the same leveling adjustments as the spreader box.

9.2.1.3 The filling of ruts 12.7 mm or greater in depth shall be filled with a rut filling spreader box 1.52 or 1.81 m wide. The rut box shall be so designed as to include fixed augers in the box to move material to the deepest portion of the rut and to provide variable depth control.

9.2.2 *Auxiliary Equipment*—Hand, squeegees, shovels, traffic control equipment and other support and safety equipment shall be provided if necessary to perform the work.

9.2.3 *Cleaning Equipment*—Power brooms, power blowers, air compressors, water flushing equipment, and hand brooms suitable for cleaning the surface and cracks of the old surface.

9.3 *Calibration*—Each mixing unit to be used in the performance of the work shall be calibrated prior to construction. Calibration documentation shall include an individual calibration of each material at various settings, which can be related to the machine metering devices. No machine will be allowed to work on the project until a calibration has been completed or accepted, or both.

### 9.4 Preparation of Surface:

9.4.1 Immediately prior to applying the microsurfacing, clean the surface of all loose material, silt spots, vegetation and other objectionable material. Any standard cleaning method used to clean pavements will be acceptable. If water is used, cracks shall be allowed to dry thoroughly before applying the microsurfacing. Manholes, valve boxes, drop inlets and other service entrances shall be protected from the microsurfacing by a suitable method.

9.4.2 If the pavement area to be covered is extremely dry and raveled or is concrete or brick, a tack coat may be required. The tack coat should consist of one part emulsified asphalt and three parts water and be applied with a standard distributor. Emulsified asphalt should be a SS or CSS grade. The tack coat shall be applied at the rate of 0.16 to 0.32 L/m<sup>2</sup>. The tack coat shall be allowed to cure sufficiently before the application of microsurfacing.

9.5 *Weather Limitations*—Microsurfacing shall not be applied if either the pavement or air temperature is below 10°C and falling, but may be applied when both pavement and air temperature are above 7°C and rising. No microsurfacing shall be applied when there is the possibility that the finished product will freeze within 24 h. The mixture shall not be applied when weather conditions prolong opening to traffic beyond a reasonable time.

9.6 *Traffic Control*—Suitable methods should be used to protect the microsurfacing from all types of traffic until sufficiently cured to accept traffic.

### 9.7 Application:

**TABLE 3 Compatibility Classification System**

Grade Rating, Each Test	Point Rating, Each Test	Abrasion Loss, grams	Adhesion 30' Boil, % Coated	Integrity 30' Retained	Boil %
A	4	0–0.7	90–100	90–100	
B	3	0.71–1.0	75–90	75–90	
C	2	1.01–1.3	50–75	50–75	
D	1	1.31–2.0	10–50	10–50	
0	0	2.01+	0	0	

9.7.1 The surface may be prewetted by water fogging ahead of the spreader box when road conditions require. The rate of application of the fog spray shall be adjusted during the day to suit temperatures, surface texture, humidity and dryness of the pavement.

9.7.2 The microsurfacing shall be of the desired consistency upon leaving the mixer. A sufficient amount of material shall be carried in all parts of the spreader box at all times so that a complete coverage is obtained. Overloading of the spreader box shall be avoided. No lumping, balling or unmixed aggregate shall be permitted.

9.7.3 No streaks such as those caused by oversized aggregate shall be left in the finished surface. No excess streaking will be allowed. Excess streaking is defined as more than four drag marks greater than 12.7 or 100 mm long; or both, or 25.4 and 76.2 mm in any 25 m<sup>2</sup>. No transverse ripples or longitudinal streaks of 6 mm in depth will be permitted when measured by placing a 3 mm straight edge over the surface.

9.7.4 No excess build-up, uncovered areas or unsightly appearance shall be permitted on longitudinal transverse joints. Suitable width spreading equipment shall be used to produce a minimum number of longitudinal joints. When possible, longitudinal joints should be placed on lane lines. Half passes and odd width passes will be used only in minimum amounts. If half passes are used, they shall not be the last pass of any paved area. A maximum of 76.2 mm shall be allowed for overlap of longitudinal lane line joints. The joint shall have no more than a 6 mm difference in elevation when measured by placing a 3 m straight edge over the joint and measuring the elevation drop-off.

9.7.5 Areas which cannot be reached with the mixing machine shall be surfaced using hand squeegees to provide a complete and uniform coverage. If necessary, the area to be handworked shall be lightly dampened prior to mix placement. Care shall be exercised to leave no unsightly appearance from handling. The same type of finish as applied by the spreader box shall be required.

9.7.6 Care shall be taken to insure straight lines along curbs and shoulders. No run-off of these areas will be permitted. However, the shoulder area must be in good condition with no substantial drop-off to curb to insure no run-off. Lines at intersections will be kept straight to provide a good appearance. If necessary, a suitable material will be used to mask off the end of streets to provide straight lines. Edge lines should not vary by more than ± 50 mm horizontal variance in any 30 m of length.

9.7.7 All areas such as manways, gutters, and intersections shall have microsurfacing mix removed on a daily basis. Debris associated with the performance of the work shall be removed as per local specifications.

**10. Keywords**

10.1 abrasion loss; consistency; lateral displacement; microsurfacing; polymer modified emulsified asphalt; quick traffic-system, set and cure time; rut-fill; specialized mixing and application equipment; stability

**APPENDIX**

**(Nonmandatory Information)**

**X1. REPROFILING RUTTED WHEELPATHS WITH MICROSURFACING**

**X1.1 Rule of Thumb:**

X1.1.1 For every 2.54 cm of microsurfacing mix add 3.2 to 6.4 mm of material As a crown to allow for compaction under traffic (see Fig. X1.1).

X1.2 When estimating quantities needed to level ruts with microsurfacing, the exact amount of material needed is very difficult to calculate. The depth and width of ruts vary drastically throughout the length of a project. Following is an approximate quantity chart for varying depths of ruts, for

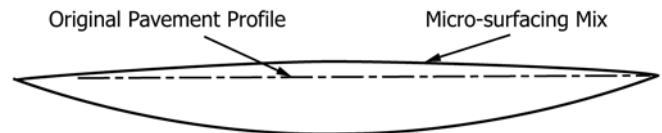

**FIG. X1.1 Rut in Wheelpath**

estimating purposes. See Table X1.1

**TABLE X1.1 Quantity Chart for Depth of Ruts**

Rut Depth, mm	kg/sqm
8.5 to 12	9.1 to 13.6
13 to 26.4	11.4 to 15.9
25.4 to 31.7	12.7 to 17.3
31.7 to 38.1	14.5 to 18.2

*ASTM International takes no position respecting the validity of any patent rights asserted in connection with any item mentioned in this standard. Users of this standard are expressly advised that determination of the validity of any such patent rights, and the risk of infringement of such rights, are entirely their own responsibility.*

*This standard is subject to revision at any time by the responsible technical committee and must be reviewed every five years and if not revised, either reapproved or withdrawn. Your comments are invited either for revision of this standard or for additional standards and should be addressed to ASTM International Headquarters. Your comments will receive careful consideration at a meeting of the responsible technical committee, which you may attend. If you feel that your comments have not received a fair hearing you should make your views known to the ASTM Committee on Standards, at the address shown below.*

*This standard is copyrighted by ASTM International, 100 Barr Harbor Drive, PO Box C700, West Conshohocken, PA 19428-2959, United States. Individual reprints (single or multiple copies) of this standard may be obtained by contacting ASTM at the above address or at 610-832-9585 (phone), 610-832-9555 (fax), or [service@astm.org](mailto:service@astm.org) (e-mail); or through the ASTM website ([www.astm.org](http://www.astm.org)). Permission rights to photocopy the standard may also be secured from the Copyright Clearance Center, 222 Rosewood Drive, Danvers, MA 01923, Tel: (978) 646-2600; <http://www.copyright.com/>*