



# Standard Practice for Determination of Volatile Organic Compounds (Excluding Formaldehyde) Emissions from Wood-Based Panels Using Small Environmental Chambers Under Defined Test Conditions<sup>1</sup>

This standard is issued under the fixed designation D6330; the number immediately following the designation indicates the year of original adoption or, in the case of revision, the year of last revision. A number in parentheses indicates the year of last reapproval. A superscript epsilon ( $\epsilon$ ) indicates an editorial change since the last revision or reapproval.

## 1. Scope

1.1 The practice measures the volatile organic compounds (VOC), excluding formaldehyde, emitted from manufactured wood-based panels. A pre-screening analysis is used to identify the VOCs emitted from the panel. Emission factors (that is, emission rates per unit surface area) for the VOCs of interest are then determined by measuring the concentrations in a small environmental test chamber containing a specimen. The test chamber is ventilated at a constant air change rate under the standard environmental conditions. For formaldehyde determination, see Test Method [D6007](#).

1.2 This practice describes a test method that is specific to the measurement of VOC emissions from newly manufactured individual wood-based panels, such as particleboard, plywood, and oriented strand board (OSB), for the purpose of comparing the emission characteristics of different products under the standard test condition. For general guidance on conducting small environmental chamber tests, see Guide [D5116](#).

1.3 VOC concentrations in the environmental test chamber are determined by adsorption on an appropriate single adsorbent tube or multi-adsorbent tube, followed by thermal desorption and combined gas chromatograph/mass spectrometry (GC/MS) or gas chromatograph/flame ionization detection (GC/FID). The air sampling procedure and the analytical method recommended in this practice are generally valid for the identification and quantification of VOCs with saturation vapor pressure between 500 and 0.01 kPa at 25°C, depending on the selection of adsorbent(s).

NOTE 1—VOCs being captured by an adsorbent tube depend on the adsorbent(s) and sampling procedure selected (see Practice [D6196](#)). The user should have a thorough understanding of the limitations of each adsorbent used.

<sup>1</sup> This practice is under the jurisdiction of ASTM Committee [D22](#) on Air Quality and is the direct responsibility of Subcommittee [D22.05](#) on Indoor Air.

Current edition approved Nov. 1, 2014. Published November 2014. Originally approved in 1998. Last previous edition approved in 2008 as D6330 – 98 (2008). DOI: 10.1520/D6330-98R14.

1.4 The emission factors determined using the above procedure describe the emission characteristics of the specimen under the standard test condition. These data can be used directly to compare the emission characteristics of different products and to estimate the emission rates up to one month after the production. They shall not be used to predict the emission rates over longer periods of time (that is, more than one month) or under different environmental conditions.

1.5 Emission data from chamber tests can be used for predicting the impact of wood-based panels on the VOC concentrations in buildings by using an appropriate indoor air quality model, which is beyond the scope of this practice.

1.6 The values stated in SI units shall be regarded as the standard (see [IEEE/ASTM SI-10](#)).

1.7 *This practice does not purport to address all of the safety concerns, if any, associated with its use. It is the responsibility of the user of the standard to consult and establish appropriate safety and health practices and determine the applicability of regulatory limitations prior to use.* For specified hazard statements see Section 6.

## 2. Referenced Documents

2.1 *ASTM Standards:*<sup>2</sup>

[D1356 Terminology Relating to Sampling and Analysis of Atmospheres](#)

[D1914 Practice for Conversion Units and Factors Relating to Sampling and Analysis of Atmospheres](#)

[D5116 Guide for Small-Scale Environmental Chamber Determinations of Organic Emissions from Indoor Materials/Products](#)

[D6007 Test Method for Determining Formaldehyde Concentrations in Air from Wood Products Using a Small-Scale Chamber](#)

[D6196 Practice for Selection of Sorbents, Sampling, and](#)

<sup>2</sup> For referenced ASTM standards, visit the ASTM website, [www.astm.org](http://www.astm.org), or contact ASTM Customer Service at [service@astm.org](mailto:service@astm.org). For *Annual Book of ASTM Standards* volume information, refer to the standard's Document Summary page on the ASTM website.

Thermal Desorption Analysis Procedures for Volatile Organic Compounds in Air

E355 Practice for Gas Chromatography Terms and Relationships

E741 Test Method for Determining Air Change in a Single Zone by Means of a Tracer Gas Dilution

IEEE/ASTM SI-10 Standard for Use of the International System of Units (SI): The Modern Metric System

2.2 *Other Standard:*

EPA TO-17 Determination of Volatile Organic Compounds in Ambient Air Using Active Sampling Onto Sorbent Tubes, Compendium of Methods for the Determination of Toxic Organic Compounds in Ambient Air

### 3. Terminology

3.1 *Definitions*—For definitions and terms that are commonly used, refer to Terminology [D1356](#) and Practice [E355](#). For definitions and terms related to test methods using small-scale environmental chamber, refer to Guide [D5116](#). For an explanation of units, symbols, and conversion factors, refer to Practice [D1914](#).

3.2 *Definitions of Terms Specific to This Standard:*

3.2.1 *environmental enclosure*—a container or space in which the environmental test chamber(s) is placed. The enclosure has controlled temperature and relative humidity.

3.2.2 *loading ratio ( $m^2/m^3$ )*—the total exposed surface area of each test specimen divided by the net air volume of the environmental test chamber.

3.2.3 *nominal time constant ( $t_n$ )*—the time required to obtain one air change in the environmental test chamber, which is equal to the inverse of the air change rate.

3.2.4 *pre-screening analysis*—a procedure for identifying the VOCs emitted from a test specimen. The results are used to determine the appropriate GC/MS or GC/FID analytical method for subsequent dynamic chamber tests.

3.2.5 *standard environmental test chamber condition*—a test condition of temperature at  $23 \pm 0.5^\circ\text{C}$ , relative humidity (RH) at  $50 \pm 5\%$ , air change rate per hour in the chamber at  $1 \pm 0.03$  ACH, and chamber loading ratio at  $0.40 \pm 0.01$   $m^2/m^3$ .

3.2.5.1 *Discussion*—The VOC emission rates for wood-based panel products are generally controlled by VOC diffusions within the material. The airflow condition (air velocity and turbulence) over the test specimen has minimal effect on the emission rates; therefore, it is not specified in the standard test condition.

3.2.6 *tracer gas*—a gaseous compound that is neither emitted by the wood-based panel nor present in the supply air to the chamber. It can be used to determine the mixing characteristics of the environmental test chamber, and it provides a cross-check of the air change rate measurements.

3.2.7 *TVOC*—total concentration of all the individual volatile organic compounds (VOC) captured from air by a given sorbent, or a given combination of several sorbents, thermally desorbed into and eluted from a given gas chromatographic system and measured by a given detector. For VOC definition, see Terminology [D1356](#).

3.2.7.1 *Discussion*—The measured value of TVOC will

depend on the collection and desorption efficiency of the sorbent trap, the efficiency of transfer to the GC column, the type and size of the GC column, the GC temperature program and other chromatographic parameters, and the type of GC detector. One way to report TVOC values is recommended in [8.2.7.6](#).

3.2.8 *wood-based panel test specimen*—a specimen of a panel cut from an original wood-based panel sample, such as particleboard, oriented strand board (OSB), or plywood.

### 4. Significance and Use

4.1 The effects of VOC sources on the indoor air quality in buildings have not been well established. One basic requirement that has emerged from indoor air quality studies is the need for well-characterized test data on the emission factors of VOCs from building materials. Standard test method and procedure are a requirement for the comparison of emission factor data from different products.

4.2 This practice describes a procedure for using a small environmental test chamber to determine the emission factors of VOCs from wood-based panels over a specified period of time. A pre-screening analysis procedure is also provided to identify the VOCs emitted from the products, to determine the appropriate GC/MS or GC/FID analytical procedure, and to estimate required sampling volume for the subsequent environmental chamber testing.

4.3 Test results obtained using this practice provide a basis for comparing the VOC emission characteristics of different wood-based panel products. The emission data can be used to inform manufacturers of the VOC emissions from their products. The data can also be used to identify building materials with reduced VOC emissions over the time interval of the test.

4.4 While emission factors determined by using this practice can be used to compare different products, the concentrations measured in the chamber shall not be considered as the resultant concentrations in an actual indoor environment.

### 5. Apparatus

5.1 This practice requires the use of an environmental chamber test system, an air sample collection system, and a chemical analysis system. A general guide for conducting small environmental chamber tests is provided in Guide [D5116](#). The following paragraphs describe the requirements that are specific to this practice:

5.2 *Environmental Chamber Testing System*—The system shall include an environmental test chamber, an environmental enclosure, equipment for supplying clean and conditioned air to the chamber, and outlet fittings for sampling the air exhausted from the chamber. [Fig. 1](#) illustrates an example of such systems. All materials and components in contact with panel specimen or air stream from the chamber inlet to sample collection point shall be chemically inert and accessible for cleaning. Suitable materials include stainless steel and glass. All gaskets and flexible components shall be made from chemically inert materials.

5.2.1 *Environmental Test Chamber*—The chamber should have a volume of  $0.05$   $m^3$  with the interior dimensions of  $0.5$

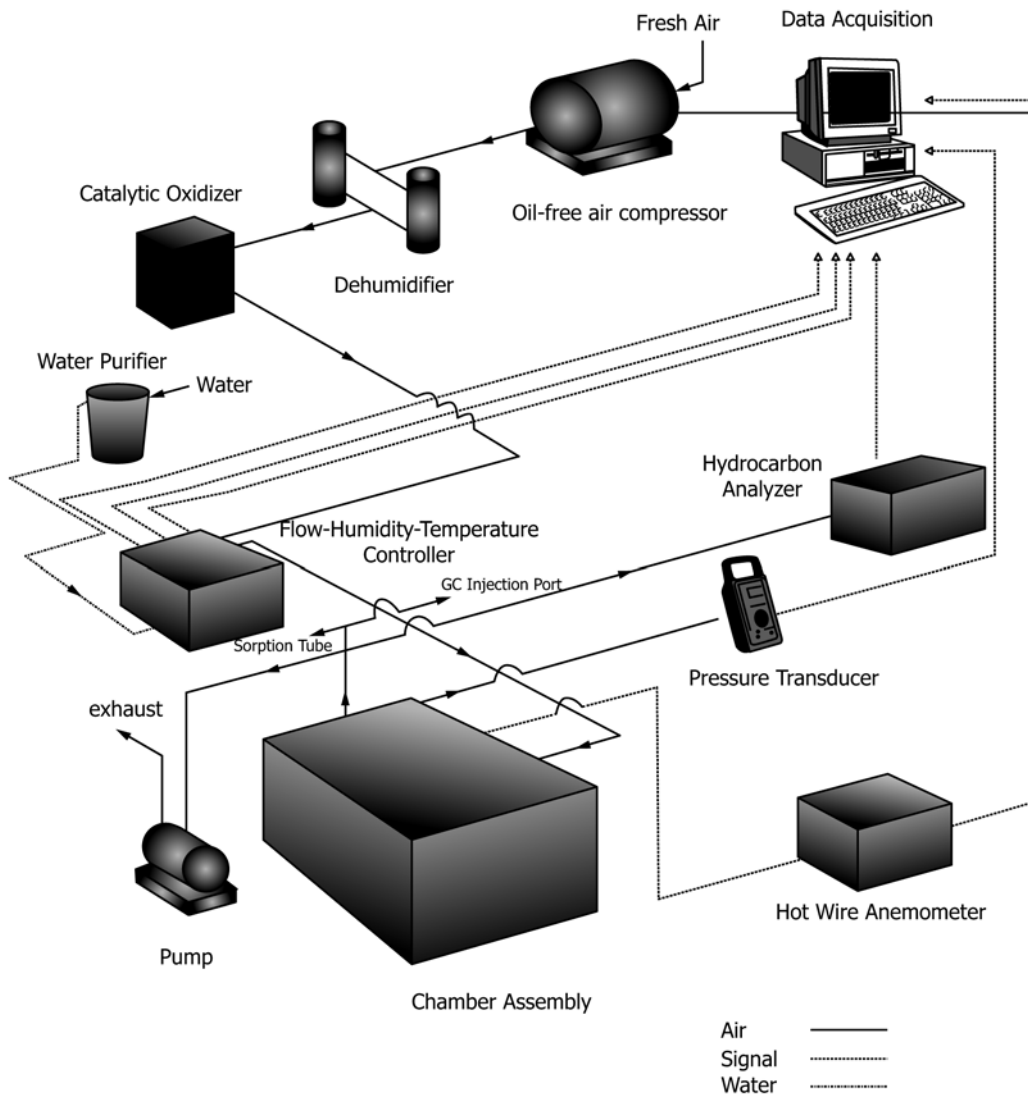

NOTE 1—The chamber assembly should be contained in an environmental enclosure to maintain the required temperature.

FIG. 1 Schematic of an Example Small Chamber Test System

by 0.4 by 0.25-m high. A chamber with a different size and shape may also be used if the same standard environmental test chamber conditions (see 3.2.5) can be maintained. The chamber shall include a supply air system having an inlet port with distributed openings to assist mixing between the supply air and chamber air and an outlet port with distributed exhaust openings to ensure that concentration measured at the chamber exhaust is the average concentration in the chamber. The chamber criteria are as follows:

5.2.1.1 *Air-Tightness of the Chamber*—The nominal air leakage rate of the chamber shall be less than 1 % of the air change rate used for the emission test at 10 Pa. Air-tightness is measured as follows: (1) seal the outlet of the chamber; (2) supply air to the chamber through the inlet and adjust the airflow rate so that the pressure difference between the inside and outside of the chamber is maintained at  $10 \pm 1$  Pa, which is measured by a pressure transducer with a minimum specified accuracy of  $\pm 1$  Pa; and (3) measure the airflow rate. The rate is the nominal leakage rate of the chamber.

5.2.1.2 *Air Mixing in the Chamber*—Adequate air mixing in the chamber shall be achieved to ensure that concentrations measured at the chamber exhaust are representative of those in the chamber. This may be determined by using the following tracer gas decay method: (1) place a small mixing fan (for example, a personal computer cooling fan) in the chamber; (2) operate the chamber under the standard test condition and turn on the mixing fan; (3) inject a small amount (a pulse) of an inert tracer gas into the chamber directly or by means of the supply air; (4) allow 5 min for the gas to mix with the chamber air; (5) turn off the mixing fan and record the time as  $t = 0$ ; and (6) measure the concentrations of the tracer gas at the exhaust of the chamber at the following time points:  $t = 0, 0.25 t_n, 0.5 t_n, 1.0 t_n, 1.5 t_n,$  and  $2.0 t_n$ , where  $t_n$  is the nominal time constant and is equal to 1.0 h for the standard test condition. The measured concentrations are compared to the values given by the following theoretical equation under the perfect mixing condition (in which the concentrations measured at the exhaust are the same as those in the chamber):

$$C_{(t)} = C_0 e^{-Nt} \quad (1)$$

where:

- $C_0$  = initial concentration at  $t=0$ ,  $\mu\text{g}/\text{m}^3$ ,
- $C_{(t)}$  = concentration at time  $t$ ,  $\mu\text{g}/\text{m}^3$ ,
- $N$  = air change rate,  $\text{h}^{-1}$ , and
- $t$  = time from the start of the air purging, h.

The maximum difference between the measured and calculated theoretical values shall be within  $\pm 5\%$  of the theoretical value. The above mixing test shall be conducted with a simulated test specimen placed in the chamber.

NOTE 2—The above test method is a simplified version of the decay method described in Guide D5116. Alternatively, the method of determining adequate air mixing described in Guide D5116 may also be used to check the mixing condition in the chamber.

5.2.1.3 *Sample Specimen Holder*—A sample specimen holder shall be used to hold the test specimen so that only the test surface of the specimen is exposed to the chamber air. The holder shall be designed to minimize the emissions from edges and non-testing surface of the specimen. A design example is shown in Fig. 2.

5.2.1.4 *Sink Effect*—The chamber and specimen holder shall have minimum sink effect. The recovery factor determined by the following procedure shall be higher than 95% for decane: (1) seal the supply inlet and exhaust of the chamber; (2) inject  $5\ \mu\text{g}$  of vaporized decane into the chamber; (3) take an air sample from the chamber exhaust at 5 min after the injection, and record this concentration as the initial concentration  $C_0$  and the time as  $t = 0$ ; (4) at  $t = 0$ , begin purging the air through the

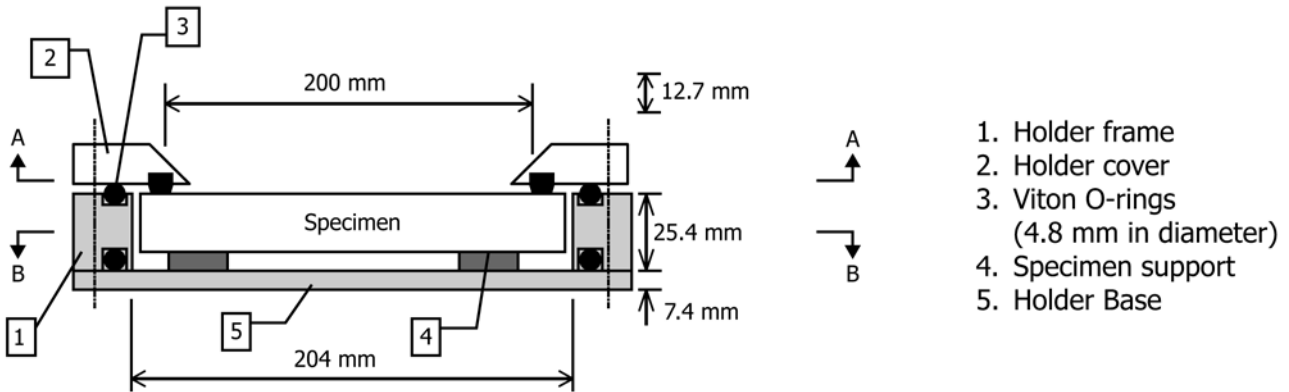

1. Holder frame
2. Holder cover
3. Viton O-rings (4.8 mm in diameter)
4. Specimen support
5. Holder Base

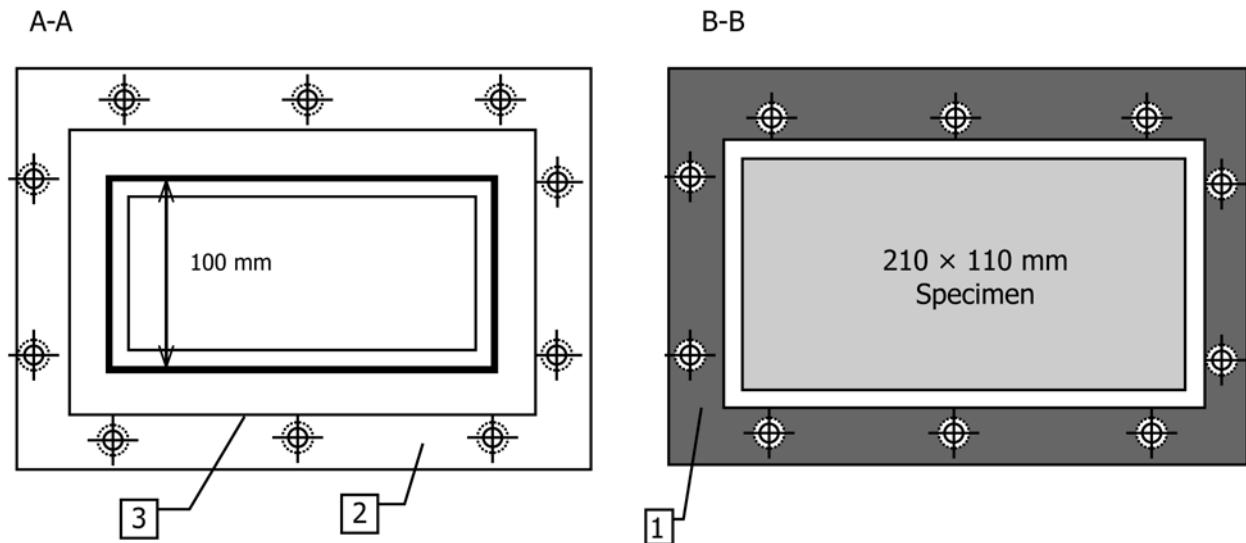

NOTE 1—All materials for the sample holder should be made of electropolished stainless steel.

FIG. 2 Schematic of an Example Sample Holder

chamber at  $t = 0$  under standard test conditions; (5) take air samples from the chamber exhaust at the following times after the start of purging:  $t_1 = 0.25 t_n$ ,  $t_2 = 0.5 t_n$ ,  $t_3 = 1.0 t_n$ ,  $t_4 = 1.5 t_n$ ,  $t_5 = 2.0 t_n$ ,  $t_6 = 3.0 t_n$ ,  $t_7 = 4.5 t_n$ ,  $t_8 = 6 t_n$ ,  $t_9 = 8 t_n$ , and  $t_{10} = 10 t_n$ , where  $t_n$  is the nominal time constant and is equal to 1.0 h for the standard test condition; and (6) calculate the recovery factor (RF) as follows:

$$RF = \frac{N}{2C_0} \sum_{i=0}^{n-1} [C(t_i) + C(t_{i+1})](t_{i+1} - t_i) 100\% \quad (2)$$

where:

- RF = recovery factor, %,
- N = air change rate,  $\text{h}^{-1}$ ,
- $C_0$  = initial concentration at  $t=0$ ,  $\mu\text{g}/\text{m}^3$ ,
- $C(t_i)$  = concentration at time  $t_i$ ,  $\mu\text{g}/\text{m}^3$  ( $i=0, 1, 2, \dots, 10$ ), and
- $t_i$  = time from the start of the air purging, h.

The above sink effect test should be conducted after the mixing condition in the chamber has been verified (see 5.2.1.2).

NOTE 3—The concentration decay is usually close to the first-order exponential decay curve (that is,  $C(t)/C_0 = e^{-Nt}$ ). The above sampling time intervals are chosen such that the amount of concentration decrease during each sampling interval will be similar.

5.2.1.5 The environmental test chamber shall be contained in an environmental enclosure (see 5.2.2).

5.2.1.6 The background concentration of the environmental test chamber is measured at the chamber exhaust. The background concentration shall meet the following criteria: (1)  $20 \mu\text{g}/\text{m}^3$  or  $1/6$  of the lowest concentration to be measured, whichever is lower, for TVOC, and (2)  $1 \mu\text{g}/\text{m}^3$  or  $1/6$  of the lowest concentrations to be measured, whichever is lower, for individual VOCs.

NOTE 4—Conventionally, the minimum quantifiable concentration is determined by:

$$C_{min} = c + 10 s \quad (3)$$

where:

- $C_{min}$  = the minimum quantifiable concentration,
- $c$  = the mean background concentration, and
- $s$  = the standard deviation of the background concentration during the test period.

For simplicity, it may be assumed that  $s = 0.5 c$ . As a result,  $C_{min} = 6 c$ .

NOTE 5—The  $20 \mu\text{g}/\text{m}^3$  limit set for TVOC in chamber air is the minimum level of cleanliness that a test chamber system shall have.

5.2.2 *Environmental Enclosure*—The enclosure is the surrounding environment of the test chamber that can maintain the temperature at  $23.0 \pm 0.5^\circ\text{C}$  and relative humidity at  $50 \pm 5\%$  RH during the period of loading the test specimen, and maintain the temperature at  $23.0 \pm 0.5^\circ\text{C}$  during the entire testing period. Once the chamber door is closed, the relative humidity in the chamber is maintained by the air supply to the chamber. A temperature ( $23.0 \pm 0.5^\circ\text{C}$ ) and humidity ( $50 \pm 5\%$  RH) controlled room is found to be adequate for this purpose. Otherwise, a stand-alone structure has to be built as the environmental enclosure.

5.2.3 *Clean Air Supply System*—The system shall be capable of supplying a controlled flow of clean air into the test

chamber. Concentrations measured at the chamber inlet shall meet the following criteria at an airflow rate  $\geq 1.0$  chamber volume per hour:

TVOC (as defined in 5.4.5.4) concentration  $\leq 10 \mu\text{g}/\text{m}^3$ ,

Concentration of any individual VOC  $\leq 0.5 \mu\text{g}/\text{m}^3$ ,

Particulate concentration  $\leq 100$  particles/ $\text{m}^3$  of  $0.5\text{-}\mu\text{m}$  diameter or larger, and

Ozone concentration  $\leq 3 \mu\text{g}/\text{m}^3$ .

A typical clean air supply system should include the following components (see Fig. 1):

5.2.3.1 An air pump(s) or an oil-free compressor capable of supplying air at a rate of 1.0 chamber volume per hour. A particulate filter shall be installed on the air intake.

5.2.3.2 A dehumidifier (for example, a desiccant drier) capable of keeping the relative humidity below 45 % RH.

5.2.3.3 A catalytic oxidizer or equivalent air purifier (for example, activated carbon filter) capable of removing organic compounds so that the concentrations of TVOC and any individual VOCs are below  $10 \mu\text{g}/\text{m}^3$  and  $0.5 \mu\text{g}/\text{m}^3$ , respectively.

5.2.3.4 An air conditioning device and an airflow controller capable of controlling the airflow rate, temperature, and relative humidity of the supply air at  $1.0 \pm 0.03$  ACH,  $23.0 \pm 0.5^\circ\text{C}$  and  $50 \pm 5\%$  RH, respectively. Deionized water (or equivalent) shall be used in the humidification.

5.2.3.5 An exhaust air pump and an airflow controller for controlling the pressure in the chamber. The airflow controller shall be adjusted so that the air pressure in the chamber will be positive relative to air pressure outside the chamber despite the fluctuations in the ambient air pressure. A typical pressure to be maintained in the chamber is  $10 \pm 5$  Pa relative to the ambient pressure outside of the chamber.

5.2.3.6 Sensors and a recording system for monitoring airflow rate, temperature, relative humidity, and pressure inside the environmental test chamber.

5.3 *Air Sampling System*—The system shall include an adsorbent tube, a mechanical pump, and an airflow controller, which can measure and control the airflow rate through the sampling system to within  $\pm 5\%$  of a specified value. All system components between the chamber and the adsorbent tube shall be constructed of chemically inert materials.

5.3.1 The adsorbent tube should be connected as close to the chamber exhaust as possible by using a short ( $<0.15$  m from the environmental enclosure) stainless steel or PTFE tube/connector. The pump shall be operated in vacuum mode downstream of the adsorbent tube to avoid contamination of air samples by the pump.

5.3.2 For effective collections of VOCs in the exhaust air of the test chamber, an appropriate single or multi-layered adsorbent tube should be used depending on the VOCs to be measured.

5.3.3 Sampling of the exhaust air shall not affect the control of airflow rate to the test chamber. The airflow controller for the exhaust air pump shall be adjusted before air sampling so that the air pressure in the chamber will remain positive during the sample collection period. A sampling flow rate of less than one third of the total supply airflow rate to the test chamber is

recommended to avoid excessive depressurization in the chamber during the sampling period. The manufacturer's recommendations for proper use of adsorbent tubes shall be followed for selecting the sampling airflow rate and for the sampling period to avoid breakthrough of VOCs. Air sample volumes (that is, sampling flow rate times the sampling period) should be determined by (1) the safe sampling volume (SSV, see Practice D6196) of the least retained VOC, (2) concentrations to be measured, (3) and detection limits of the analytical method. Proper air sample volumes may be determined by use of data from the pre-screening analysis (see 8.1).

**5.4 Chemical Analysis System**—The chemical analysis system shall include a thermal desorption unit connected to a GC/MS system or a GC/FID system. EPA TO-17 may be consulted for general procedures of determining VOCs in air sample. The chemical analysis system that is specific to this practice is as follows:

**5.4.1** A single or multi-tube thermal desorption (TD) unit shall have desorption efficiency of greater than 90 % for VOCs of interest in general, and  $100 \pm 5$  % for toluene, decane, and dodecane at 50 ng per compound per tube. Desorption efficiency should be determined by comparing results from thermal desorption with direct GC injection.

**5.4.2** GC/MS system can be used for both identification of VOCs in the pre-screening analysis and quantification of the VOCs in emissions from the environmental chamber tests.

**5.4.2.1** For identification of VOCs, the GC/MS is operated in the scan mode and shall be capable of scanning the mass range from 15 to 350 amu (atomic mass unit). The measured mass spectrum shall be compared to those in a standard mass spectrum library to identify the individual VOCs detected. Selected VOCs of interest shall be confirmed by spiking with the corresponding standards (see 8.1).

**5.4.2.2** For quantification of individual VOCs of interest, the GC/MS system shall be operated in the scan mode or in the selected ion monitoring (SIM) modes. If SIM mode is selected, at least three ions shall be monitored for each VOC of interest. Other conditions used in 5.4.2.1 shall be maintained.

**5.4.3** GC/FID system can be used for quantification of VOCs of interest as an alternative to GC/MS. The identification of the VOCs of interest in a GC/FID chromatogram shall be confirmed by GC/MS analysis and by spiking with the corresponding standards (see 8.1).

**5.4.4** Optimal operating conditions (GC column and temperature program) shall be determined for GC/MS and GC/FID system based on data from the pre-screening analysis (see 8.1).

**5.4.5** Chemical and analytical system shall be properly calibrated for quantitative analysis. Initial calibration of GC/MS or GC/FID system shall be completed before testing each type of product material. Initial calibration shall be conducted by analyzing standards of selected VOCs (or toluene for TVOC, see 5.4.5.4) at different concentrations. At least five different concentrations covering anticipated VOC concentration range in the test are needed for such calibration. The user of this practice shall demonstrate that the analytical system has a linear response over the anticipated VOC concentration range.

**5.4.5.1** If GC/FID system is used for the quantification, single point calibration checking shall be conducted on each day the system is used. If the result of such single point checking deviates less than  $\pm 10$  % from the initial calibration line, the initial calibration line shall be used to calculate the mass concentrations. Otherwise, the problem shall be identified and the system fully re-calibrated as in the initial calibration (see 5.4.5).

**5.4.5.2** If GC/MS system is used for the quantification, daily calibration shall be conducted at two concentration levels (that is, a two-point calibration) as a minimum. The low point should be where the linearity of the calibration curve starts or ten times the method detection limit, whichever is higher. The high point should be where the linearity of the calibration curve ends or the anticipated highest concentration in the samples, whichever is lower. Results of this daily calibration shall be used to calculate the concentrations if they deviate less than 10 % from the previous day and less than 25 % from the initial calibration. Otherwise, the problem shall be identified and the system fully re-calibrated as in the initial calibration (see 5.4.5).

**NOTE 6**—Different calibration practices are specified for GC/FID (see 5.4.5.1) and GC/MS (see 5.4.5.2) system because a GC/MS system is usually subject to more day to day variations than a GC/FID system.

**5.4.5.3** If the testing objective is to measure the emission factors of target individual compound, the TD-GC/MS or TD-GC/FID system shall be calibrated for each individual compound with standards of the same compound.

**5.4.5.4** If the testing objective is to measure TVOC concentration, the TD-GC/FID system or TD-GC/MS system shall be calibrated by using toluene as the reference standard. The result shall be reported as the concentration of toluene equivalent TVOC-by-GC/FID or TVOC-by-GC/MS, depending on which system is used. GC/MS system in this case shall be operated in full scan mode (15 to 350 amu) and peak areas of the total ion currency shall be used.

**5.4.5.5** If the testing objective is to measure both the concentrations of TVOC and individual target compounds, the TD-GC/FID system or TD-GC/MS system shall be calibrated for both toluene and individual target compounds.

**5.5** The method detection limit of the system shall be less than one third of the lowest concentration to be measured.

## **6. Hazards**

**6.1** The transportation, handling, cutting, testing and clean-up of wood-based panel materials involve a number of chemical and physical hazards.

**6.2** Proper workplace health and safety procedures and good laboratory practice shall be developed and implemented.

**6.3 Chemicals**—Appropriate procedures shall be developed and implemented for using and disposing of chemicals for cleaning and calibration.

## **7. Material Sampling, Storage, Preparation of a Test Specimen, and Its Placement in the Environmental Test Chamber**

**7.1** *Material Collection, Packaging, and Transportation:*

7.1.1 Sample materials shall be handled in an unbiased manner. They should be collected at the point of manufacturer by a qualified person and delivered directly to the testing laboratory using the following procedure:

7.1.1.1 Select one panel from the center of a freshly (within a week) manufactured stack.

7.1.1.2 Cut 300 by 300-mm (1 by 1-ft) sample(s) from selected panel at a minimum distance of 300 mm (1 ft) from the edges and ends.

7.1.1.3 Wrap each sample separately in clean aluminum foil (no tape, shiny side out), and place wrapped samples in a clean bag. The bag and aluminum foil shall be provided by the testing laboratory. The TVOC concentration in the headspace of the empty bag shall be less than  $50 \mu\text{g}/\text{m}^3$ , and concentration of any single component shall be less than  $5 \mu\text{g}/\text{m}^3$ . This can be checked by filling the bags with clean air and taking an air sample after 24 h. The aluminum foil shall be kept clean by placing it in a separate bag when shipping it to the manufacturer for collecting material samples.

7.1.1.4 Send samples to the testing laboratory. Samples shall be received by the testing laboratory within 48 h.

7.2 *Sample Storage*—After receipt, the testing laboratory shall store sample materials at a temperature of  $23.0 \pm 1.0^\circ\text{C}$  without direct exposure to the lights. The minimum storage time shall be 48 h to allow equalization of the sample temperature with the ambient air. The sample materials shall be tested within 14 days after being received.

### 7.3 *Preparation of Test Specimens:*

7.3.1 Prior to testing, use a clean saw to cut the sample material into a standard size (210 by 110-mm) specimen, which includes 5 mm on each side to be sealed by the specimen tray. The saw shall be cleaned by wiping several times with methanol, rinsing thoroughly with deionized water, and drying with clean laboratory tissue paper.

7.3.2 Seal all of the four edges and the non-testing surface using a specimen holder (see 5.2.1.3). The exact exposed testing surface area shall be  $0.02 \text{ m}^2$  (200 by 100-mm).

7.4 *Placement of the Test Specimen in the Environmental Test Chamber*—Place the specimen on the center floor (bottom) of the chamber so that air circulation in the chamber is not affected by the specimen. The preparation time (that is, from opening the sample bag to placing the specimen in the chamber) should be controlled within 20 to 30 min.

## 8. Test Procedure

### 8.1 *Pre-Screening Analysis Procedure:*

8.1.1 Pre-screening analysis is conducted to accomplish the following: identifies the VOCs emitted by the product; establishes proper operating conditions for the GC/MS or GC/FID system, or both; enables selection of target VOCs; and enables determination of proper air sampling volume for subsequent environmental chamber tests.

8.1.2 The environmental test chamber (see 5.2.1) shall be operated using the following procedure for this purpose:

8.1.2.1 Prepare environmental test chamber and load the specimen according to procedure in 8.2.1 – 8.2.5.

8.1.2.2 Take first air sample after at least six air changes at the standard airflow rate (that is, 6 h using standard conditions) have passed through the environmental test chamber. This is to ensure that approximately 99.75 % of the background contaminants introduced during the sample loading are removed.

8.1.2.3 Take multiple air samples with different air volumes ranging from low to high (for example, 1, 3, and 5 L). If the concentration in the chamber is too low for identification by a GC/MS system operating in the full scan mode, the supply airflow rate may be shut off for a certain period of time (for example, 24 hours) to allow concentration in the chamber to build up.

8.1.2.4 Analyze the air samples by using the TD-GC/MS (preferably in the order of low to high volume samples to avoid possible over loading of the analytical system). Different GC operating parameters (columns and temperature program) may be tested to obtain a good separation of emitted VOCs. The results will be used to determine a proper set of GC operating parameters for subsequent environmental chamber testing. More air samples may be taken from the environmental test chamber if necessary.

8.1.3 Identify GC peaks based on the results of GC/MS analysis (see 5.4.2). The selection of VOCs for subsequent environmental chamber testing depends on the objective of the testing. Confirm the identification of each selected VOC by spiking with a corresponding standard of each selected VOC.

8.1.4 Estimate the proper air sample volumes at  $t = 24 \text{ h}$  and  $t = 72 \text{ h}$  for the subsequent environmental chamber tests according to VOC concentrations in the air samples (see 8.1.2.3). The air sample should contain VOC mass at least three times, preferably ten times, higher than the detection limit of the analytical system. For example, if the detection limit of a TD-GC/MS system is  $0.001 \mu\text{g}$  per sample tube for a VOC of interest, and the concentration of that VOC in chamber air is  $1.0 \mu\text{g}/\text{m}^3$ , a minimum air sample volume of  $0.003 \text{ m}^3$  should be collected ( $0.001 \mu\text{g} \times 3 / 1.0 \mu\text{g}/\text{m}^3 = 0.003 \text{ m}^3$ ).

### 8.2 *Environmental Chamber Testing Procedure:*

8.2.1 Place the environmental test chamber in the environmental enclosure. Prior to testing, clean the environmental test chamber and all internal hardware and equipment by wiping the interior surfaces with an alkaline detergent, followed by a thorough rinsing with tap water, wiping with methanol, rinsing thoroughly with deionized water, and drying with clean laboratory tissue paper.

NOTE 7—The cleaning procedure described here is recommended if the chamber has not been used for a long time or previous sample contained high VOC concentrations. For normal operation, wiping and rinsing with deionized water may be sufficient after each test. Check the chamber air after cleaning for acceptable background level.

8.2.2 Operate the environmental test chamber under the standard environmental test conditions (that is,  $23^\circ\text{C}$ , 50 % RH and  $1 \text{ h}^{-1}$ ). Operate the chamber so that positive chamber pressure is maintained at  $10 \pm 5 \text{ Pa}$  during testing and air sample collection (see 8.2.6).

8.2.3 Draw a 10-L air sample after a minimum of 6 h to check the background concentration in the chamber. The background VOC concentration ( $C_{bk}$ ), shall meet the criteria specified in 5.2.1.6. Otherwise check the testing system for the

cause of the excessive background contamination and take actions to eliminate contamination.

8.2.4 Prepare the test specimen and place it in the specimen holder according to 7.3.

8.2.5 Open the door of the environmental test chamber, load the test specimen into the chamber, position the specimen at the center of the chamber bottom, and close the chamber. Keep supply air flowing through the chamber during specimen loading. Record the time when the chamber door is closed. This shall be defined as the *time zero* for the environmental chamber testing.

#### 8.2.6 Sampling:

8.2.6.1 Select adsorbent tubes packed with adsorbent(s) according to Practice D6196.

8.2.6.2 Clean and condition the adsorbent tubes within 72 h prior to emission sampling.

8.2.6.3 Configure the exhaust system to have part of the exhaust going through sampling port/line.

8.2.6.4 Draw air samples at 24 h and 72 h from the time zero (see 8.2.5) to determine the concentrations of TVOC and individual VOCs of interest at these two times.

8.2.6.5 Seal both ends of the tube after sampling, and store the tube in a clean environment at room temperature until analysis. The tubes shall be analyzed within ten days after the sample collection.

8.2.6.6 If duplicate air samples are collected, separate flow controllers shall be used for each adsorbent tube, and the exact flow rate for each tube shall be recorded.

NOTE 8—Take additional emission samples before 24 h, between 24 and 72 h, and after 72 h if more detailed characterization of the VOC emissions is desired.

8.2.6.7 Remove the specimen from the chamber after the 72-h air sample has been drawn. Draw an air sample from the air supply tube/line immediately upstream of the chamber to verify the background concentration of the supply air. If the background concentration exceeds the criteria specified in 5.2.3, identify and correct the problem(s), and then repeat the test.

#### 8.2.7 Chemical Analysis:

8.2.7.1 Prepare standard solutions for calibration in methanol or other appropriate solvents using the following procedure: (1) take 1 to 5  $\mu\text{L}$  of standard solution using a syringe; (2) transfer the liquid in the syringe onto the tube under a clean air flow, and (3) purge the tube with a volume of clean air sufficient to remove methanol or other solvents from the tube. The volume of purge air will depend upon adsorbent(s) selected. A small volume (less than 0.5  $\mu\text{L}$ ) of solution shall be loaded onto adsorbent tubes if solvents can not be removed from the adsorbent tube.

8.2.7.2 Check the instrument performance before analysis. If GC/MS system is used, tune the instrument using manufacturers predefined autotune procedure. The system shall pass manufacturer's autotune criteria. If GC/FID is used, make sure the detector is turned on and is stabilized before sample analysis.

8.2.7.3 Calibrate the analytical system according to 5.4.5.

8.2.7.4 Analyze all air samples collected during the chamber test and associated quality control samples (for example,

blanks, duplicates) in one analytical sequence within ten days from the first air sample that was collected.

8.2.7.5 Calculate VOC concentrations using the test method in 5.4.5.1 for GC/FID system and 5.4.5.2 for GC/MS system.

8.2.7.6 Calculate TVOC defined in 5.4.5.4, if required, using the following procedures: (1) convert the area count of each peak to the equivalent toluene mass by using the calibration curve for toluene; and (2) sum all the equivalent toluene masses. The result of the total mass summation is the TVOC-by-GC/FID mass if GC/FID is used, and TVOC-by-GC/MS if GC/MS is used.

NOTE 9—The total mass of VOCs determined also depends on the adsorbent(s) used for the collection of emission samples. The reported TVOC value shall have a qualifying statement that defines the range of VOCs that can be effectively captured and measured by a given method. It is recommended that the VOC range, expressed as vapor pressure (v.p.) at 25°C, of a given method be reported in parentheses with TVOC results, for example, TVOC-by-GC/MS (v.p. 150 to 0.3 kPa) = 10  $\text{mg}/\text{m}^3$ .

## 9. Data Analysis and Interpretation

9.1 The emissions of VOCs from wood-based panels are generally characterized by slowly decaying emission rates. For the purpose of this practice, the emission factor is assumed to follow a first order exponential decay:

$$EF_{(t)} = EF_0 e^{-kt} \quad (4)$$

where:

$EF_{(t)}$  = emission factor at time  $t$ ,  $\mu\text{g}/\text{m}^2\text{h}$ ,  
 $EF_0$  = initial emission factor at time zero,  $\mu\text{g}/\text{m}^2\text{h}$ , and  
 $k$  = exponential decay constant,  $\text{h}^{-1}$ .

NOTE 10—The first order exponential decay model is used in this practice because of its simplicity and adequacy to represent the emission test data. Caution shall be exercised when it is used to predict emission rates for a longer term.

For an individual VOC of interest or TVOC,  $EF_0$  and  $k$  can be calculated by the following simplified procedure:<sup>3</sup>

9.1.1 Determine the concentrations for the emission samples taken at the elapsed times of  $t_1 = 24$  h and  $t_2 = 72$  h, and denote them as  $C_1$  and  $C_2$ , respectively.

9.1.2 Calculate the corrected concentrations as:

$$C_{1,c} = C_1 - C_{bk} \quad (5)$$

$$C_{2,c} = C_2 - C_{bk} \quad (6)$$

where:

$C_{1,c}$  = corrected concentration in the chamber measured at  $t_1 = 24$  h,

$C_{2,c}$  = corrected concentration in the chamber measured at  $t_2 = 72$  h, and

$C_{bk}$  = background concentration in the chamber (see 5.2.1.6).

9.1.3 Calculate the first approximations of emission factors at  $t_1$  and  $t_2$  by the following equations:

$$ef_1 = C_{1,c} N/L \quad (7)$$

$$ef_2 = C_{2,c} N/L \quad (8)$$

<sup>3</sup> Zhang, J.S., Wang, J.M., and Shaw, C.Y., "A theoretical examination of a simplified procedure for data analysis in small chamber testing of material emissions," IRC/NRC internal report (IRC-IR-733), IRC/NRC CMEIAQ Report 1.1, 1997.



where:

- $ef_1$  = first approximation of the emission factor at  $t_1 = 24$  h,
- $ef_2$  = first approximation of the emission factor at  $t_2 = 72$  h,
- $L$  = loading ratio of specimen in the chamber,  $m^2/m^3$ , and
- $N$  = air change rate,  $h^{-1}$ .

9.1.4 Calculate  $k$  and  $EF_0$  by using the following equations:

$$k = [\ln(ef_1/ef_2)]/\Delta t \quad (9)$$

$$EF_0 = (1 - k/N) ef_1 / [(ef_1/ef_2)^{(t1/\Delta t)}] \quad (10)$$

where:

$$\Delta t = t_2 - t_1 = 48 \text{ h.}$$

9.2 The above simplified calculation procedure is valid in general assuming that the measurement of the concentrations  $C_{1,c}$  and  $C_{2,c}$  are accurate and  $EF = EF_0 e^{-kt}$  is valid. However, current air sampling and chemical analysis techniques can only provide a precision of about  $\pm 10\%$  (relative standard deviation). As a result, sources with  $|k| < 5.0 \times 10^{-3}$ , shall be regarded as constant emitters. In this case, the testing results shall be reported as follows:

$$k = 0$$

$$EF = (ef_1 + ef_2)/2$$

NOTE 11—For specimen with very slow decay of emissions, an alternative way is to increase  $t_2$  to 96 or 120 h ( $\Delta t = 72$  h or 96 h) so that decay constant that is less than  $5.0 \times 10^{-3}$  can also be measured.

NOTE 12—With the two corrected concentrations  $C_{1,c}$  and  $C_{2,c}$ , the initial emission factor ( $EF_0$ ) and the decay constant ( $k$ ) can in fact be computed by an iteration procedure with no approximation required (that is, the exact solution can be found). The simplified procedure described above is adopted in this practice because it is simpler to use and provides sufficient accuracy. If more air samples are taken, regression analysis can also be used to determine  $EF_0$  and  $k$ . Users shall refer to Guide D5116 for the detailed calculation procedure.

## 10. Report

10.1 The report shall include the following information:

10.1.1 *Testing Objectives*—The purpose of the testing project and intended use of the results shall be stated.

10.1.2 *Testing Laboratory Identification*, the name, address, phone/fax numbers, and contact person.

10.1.3 *Product Identification*—The name, specific identifiers from the manufacturer and a brief description of the product, its application, and history shall be provided.

10.1.4 *Collection and Handling of Sample Materials*, sample receipt date, storage time and conditions, and specimen preparation.

10.1.5 *Facility and Equipment Identification*, a general description of the facilities and equipment, including chemical sampling and analysis.

10.1.6 *Test Conditions*, including temperature, humidity, air change rate, and dimensions of the test specimen.

10.1.7 *Results*—(1) Names of VOCs identified in the pre-screening analysis; (2) basis of selecting the individual VOCs for environmental chamber testing; (3) initial emission factors,  $EF_0$ , and the exponential decay constants,  $k$ , calculated for TVOC, and the selected individual VOCs according to the procedure in Section 9.

10.1.8 *Reference*—Reference to this practice and state any variations in the test procedure from this practice.

10.2 All values shall be reported in SI unit unless specified otherwise.

## 11. Quality Control and Quality Assurance

11.1 A quality assurance and quality control (QA/QC) plan shall be designed and implemented to ensure the integrity of the measured and reported data obtained during product evaluation studies. This plan shall encompass all facets of the measurement program from sample receipt to final review and issuance of reports.

11.2 *Data Quality Objectives and Acceptance Criteria*—The QA/QC plan shall be based on established data quality objectives and acceptance criteria, which will depend on the purpose of the testing and the capability of the laboratory (equipment and personnel) to conduct the test procedures. Data quality objectives shall be established for the following parameters prior to initiating the testing program:

11.2.1 *Test Sample Transfer Time and Environmental Conditions*—Tolerance limits shall be established for the duration time from sample production to testing under an acceptable range of specified environmental conditions.

11.2.2 *Test Chamber Conditions and Test Results*—Precision and accuracy limits should be met for each of the parameters in Table 1. Accuracy certifications are supplied by the manufacturers of the sensors that calibrate them against NIST-traceable primary sources. Precision measurements are obtained within the laboratory by continuous recording of the parameters. Non-compliance requires immediate correction or replacement of sensors, or both. Calibrated replacements shall be retained in the laboratory. Experience shows that routine calibration and tracking of precision can prevent noncompliance.

11.2.3 *Record Keeping and Logs*—Various documentation requirements shall be implemented for all test parameters, including environmental test chamber and analytical performance. Many of these are identified in Guide D5116. Additionally, the identity of persons conducting each procedure shall be recorded. All devices used, date and time of tests, and the test data shall be part of QA/QC recording process. Completeness of records demonstrates the care and attention given to the quality control process.

11.3 *Calibration*—Calibration shall be conducted frequently enough to ensure performance of the system within the specified parameters. Frequency of calibration shall be determined prior to the test and periodic equipment checks shall

**TABLE 1 Precision and Accuracy Limits for Test Chamber Conditions and Test Results**

Parameter	Precision	Accuracy
Chamber temperature	$\pm 0.5^\circ\text{C}$	$\pm 0.5^\circ\text{C}$
Chamber relative humidity	$\pm 5.0\%$	$\pm 5.0\%$
Air flow rate	$\pm 5.0\%$	$\pm 5.0\%$
Area of the testing surface of the specimen	$\pm 1.0\%$	$\pm 1.0\%$
Time measurement	$\pm 1.0\%$	$\pm 1.0\%$
Organic concentration	$\pm 10.0\%$ RSD <sup>A</sup>	$\pm 10.0\%$ RSD <sup>A</sup>
Emission factor	$\pm 20.0\%$ RSD <sup>A</sup>	$\pm 20.0\%$ RSD <sup>A</sup>

<sup>A</sup> RSD = Relative standard deviation, =  $(s/m) \times 100\%$ , where,  $s$  = standard deviation; and  $m$  = mean value. The RSD should be determined at the medium of the chamber concentrations observed during the test period.

verify the maintenance of acceptable performance. All calibration and verification measurements shall be recorded, including the time, equipment description, and measurement data.

11.4 *Accuracy of Test Results*—Accuracy determinations require measurements of a known emission source (for example, permeation tubes, spiked samples) or test gas. These measurements shall be made prior to establishing the project data quality objectives and shall be consistent with the overall testing objectives. The procedures and materials used for establishing accuracy of the measurement system shall be recorded.

11.5 *Precision of Test Results*—Precision determinations require replications sufficient to establish statistically validated variations associated with all measurements. When multiple chambers are used as part of an experiment, duplicate samples shall be used for this determination. Variation in test data from a single chamber and among chambers can be established by

use of standardized sources, such as permeation tubes, for determining organic concentrations and calculated emission rates.

11.6 *Duplicate Analysis*—No less than 30 % of duplicate emission samples shall be collected and analyzed. The results of such analyses shall be recorded and assessed to determine the adequacy of the total system performance relative to the testing objectives.

11.7 *Charting*—Charting quality control data will allow analysis of system performance and observation of anomalous or unacceptable deviations.

## 12. Keywords

12.1 chemical analysis; emission factors; small environmental test chamber; standard dynamic chamber test conditions; volatile organic compounds; wood-based panels

*ASTM International takes no position respecting the validity of any patent rights asserted in connection with any item mentioned in this standard. Users of this standard are expressly advised that determination of the validity of any such patent rights, and the risk of infringement of such rights, are entirely their own responsibility.*

*This standard is subject to revision at any time by the responsible technical committee and must be reviewed every five years and if not revised, either reapproved or withdrawn. Your comments are invited either for revision of this standard or for additional standards and should be addressed to ASTM International Headquarters. Your comments will receive careful consideration at a meeting of the responsible technical committee, which you may attend. If you feel that your comments have not received a fair hearing you should make your views known to the ASTM Committee on Standards, at the address shown below.*

*This standard is copyrighted by ASTM International, 100 Barr Harbor Drive, PO Box C700, West Conshohocken, PA 19428-2959, United States. Individual reprints (single or multiple copies) of this standard may be obtained by contacting ASTM at the above address or at 610-832-9585 (phone), 610-832-9555 (fax), or service@astm.org (e-mail); or through the ASTM website (www.astm.org). Permission rights to photocopy the standard may also be secured from the Copyright Clearance Center, 222 Rosewood Drive, Danvers, MA 01923, Tel: (978) 646-2600; <http://www.copyright.com/>*