



# Standard Test Method for Shake Extraction of Mining Waste by the Synthetic Precipitation Leaching Procedure<sup>1</sup>

This standard is issued under the fixed designation D6234; the number immediately following the designation indicates the year of original adoption or, in the case of revision, the year of last revision. A number in parentheses indicates the year of last reapproval. A superscript epsilon ( $\epsilon$ ) indicates an editorial change since the last revision or reapproval.

## 1. Scope

1.1 This test method covers a procedure for the shake leaching of mining waste containing at least 80 % dry solids ( $\leq 20$  % moisture) in order to generate a solution to be used to determine the inorganic constituents leached under the specified testing conditions that conform to the synthetic precipitation leaching procedure (SPLP).

1.2 This test method calls for the shaking of a known weight of mining waste with acidic extraction fluid of a specified composition as well as the separation of the liquid phase for analysis. The pH of the extraction fluid is to reflect the pH of acidic precipitation in the geographic region in which the waste being tested is to be disposed.

NOTE 1—Possible sources of information concerning the pH of the precipitation in the geographic region of interest include state and federal environmental agencies, state universities, libraries, etc. pH values given in USEPA Method 1312, that are 4.2 east of the Mississippi River and 5.0 west of the Mississippi River and are based on acid precipitation maps, are examples of values that can be used. If the pH of the laboratory water is less than the desired pH for the site, do not use this test method; use Test Method D3987 or Test Method E2242.

NOTE 2—The method may also be suitable for use in testing of mineral processing waste from meal mining process operations for jurisdictions that do not require the use of Test Method E2242.

1.3 This test method is intended to describe the procedure for performing single batch extractions only. It does not describe all types of sampling, sample preservation, and analytical requirements that may be associated with its application.

1.4 The values stated in SI units are to be regarded as the standard. No other units of measurement are included in this standard.

1.5 *This standard does not purport to address all of the safety concerns, if any, associated with its use. It is the responsibility of the user of this standard to establish appro-*

*priate safety and health practices and determine the applicability of regulatory limitations prior to use.*

## 2. Referenced Documents

### 2.1 ASTM Standards:<sup>2</sup>

- D75 Practice for Sampling Aggregates
- D420 Guide to Site Characterization for Engineering Design and Construction Purposes (Withdrawn 2011)<sup>3</sup>
- D653 Terminology Relating to Soil, Rock, and Contained Fluids
- D1129 Terminology Relating to Water
- D1193 Specification for Reagent Water
- D2234/D2234M Practice for Collection of a Gross Sample of Coal
- D2777 Practice for Determination of Precision and Bias of Applicable Test Methods of Committee D19 on Water
- D3370 Practices for Sampling Water from Closed Conduits
- D3987 Practice for Shake Extraction of Solid Waste with Water
- D5744 Test Method for Laboratory Weathering of Solid Materials Using a Humidity Cell
- E691 Practice for Conducting an Interlaboratory Study to Determine the Precision of a Test Method
- E877 Practice for Sampling and Sample Preparation of Iron Ores and Related Materials for Determination of Chemical Composition and Physical Properties
- E1915 Test Methods for Analysis of Metal Bearing Ores and Related Materials for Carbon, Sulfur, and Acid-Base Characteristics
- E2242 Test Method for Column Percolation Extraction of Mine Rock by the Meteoric Water Mobility Procedure

### 2.2 EPA Document:

- U.S. Environmental Protection Agency, Synthetic Precipitation Leaching Procedure, Method 1312 in SW-846, Test Methods for Evaluating Solid Waste, Physical/Chemical

<sup>1</sup> This test method is under the jurisdiction of ASTM Committee D34 on Waste Management and is the direct responsibility of Subcommittee D34.01.04 on Waste Leaching Techniques.

Current edition approved Sept. 1, 2013. Published September 2013. Originally approved in 1998. Last previous edition approved in 2007 as D6234-98(2007). DOI: 10.1520/D6234-13.

<sup>2</sup> For referenced ASTM standards, visit the ASTM website, www.astm.org, or contact ASTM Customer Service at service@astm.org. For *Annual Book of ASTM Standards* volume information, refer to the standard's Document Summary page on the ASTM website.

<sup>3</sup> The last approved version of this historical standard is referenced on www.astm.org.

### 3. Terminology

3.1 *Definitions*—For definitions of terms used in this test method, see Terminology **D1129**.

3.2 *Definitions of Terms Specific to This Standard:*

3.2.1 *mining waste, n*—overburden or waste rock excavated and disposed of during mining operations.

3.3 *Symbols:* Variables listed in this test method are defined in the individual sections in which they are discussed.

### 4. Significance and Use

4.1 This test method is intended as a means for obtaining an extract of mining waste. The extract may be used to estimate the release of certain inorganic constituents of the waste under the laboratory conditions described in this test method. The user is advised to minimize the holding time between sampling and testing if the waste is suspected to contain reactive sulfide minerals.

NOTE 3—This method is not intended to be used as a kinetic test to simulate weathering of mining wastes. For kinetic testing of mining wastes, refer to Test Method **D5744** to determine release rates for constituents of interest. For static testing of metal mining ore and mining or mineral processing waste materials, refer to Test Method **E1915**.

4.2 The pH of the extraction fluid used in this test method is to reflect the pH of acidic precipitation in the geographic region in which the waste being tested is to be disposed (see **1.2**).

4.3 An intent of this test method is for the final pH of the extract to reflect the interaction of the extractant with the buffering capacity of the waste.

4.4 This test method is not intended to provide an extract that is representative of the actual leachate produced from a waste in the field or to produce extracts to be used as the sole basis of engineering design. If the conditions of this test method are not suitable for the test material, USEPA Method 1312 or Test Method **E2242** may be used.

4.5 This test method has not been demonstrated to simulate actual disposal site leaching conditions.

4.6 This test method produces extracts that are amenable to the determination of both major and minor (trace) inorganic constituents. When minor constituents are being determined, it is especially important that precautions be taken in sample storage and handling to avoid possible contamination of the samples.

4.7 This test method has been tested to determine its applicability to certain inorganic components in the waste. This test method has not been tested for applicability to organic substances, volatile matter (see **Note 5**), or biologically active samples. This test method has undergone limited testing to determine its reproducibility.

### 5. Apparatus

5.1 *Straight Edge*, such as a thin-edged yardstick.

5.2 *Impermeable Sheet*, of glazed paper, oil cloth, or other flexible material of a composition suitable to the analytes of interest.

5.3 *Drying Pans or Dishes*, (for example, aluminum tins, porcelain dishes, glass weighing pans), two per waste, suitable to the waste being tested and the instructions given in **9.2**.

5.4 *Drying Oven*—Any thermostatically controlled drying oven capable of maintaining a steady temperature of  $\pm 2^\circ\text{C}$  in a range of 100 to 110°C.

5.5 *Desiccator*, having a capacity to hold the drying pans described in **5.3** and the crucibles described in **5.16**.

5.6 *Laboratory Balance*, capable of weighing to 0.1 g.

5.7 *Erlenmeyer Flask*, 2-L capacity, equipped with a magnetic stir bar.

5.8 *Magnetic Stir Plate*.

5.9 *Graduated cylinder*, 1 or 2-L capacity.

5.10 *Pipet*, 1-mL capacity.

5.11 *Volumetric Flask*, 1-L capacity.

5.12 *Pipet*, 10-mL capacity. (Various other sized pipets, including micropipets, may be necessary for **9.3.2**.)

5.13 *pH Meter*—Any pH meter with a readability of 0.01 units and an accuracy of  $\pm 0.05$  units at 25°C.

5.14 *Carboy-Type Container*, with spigot, 20 to 50-L capacity, of a composition suitable to the nature of the analyses to be performed (see Practices **D3370**).

5.15 *Large Glass Funnel*.

5.16 *Crucibles*, porcelain, 20-mL capacity each, two per waste.

5.17 *Wash Bottle*, 500-mL capacity.

5.18 *Agitation Equipment*, of any type that rotates the extraction vessel in an end-over-end fashion at a rate of  $30 \pm 2$  r/min such that the axis of rotation is horizontal and it passes through the center of the bottle (see **Fig. 1**).

5.19 *Pressure Filtration Assembly*—A pressure filtration device using pressure regulated compressed gas of a composition suitable to the nature of the analyses to be performed and equipped with a 0.45 or 0.8- $\mu\text{m}$  pore size filter (see **Note 7**).

5.20 *Extraction Vessels*, cylindrical, wide-mouth, of a composition suitable to the nature of the waste and analyses to be performed, constructed of materials that will not allow sorption of the constituents of interest, and sturdy enough to withstand the impact of the falling sample fragments. The size of the container should be selected so that the sample, plus extraction fluid occupy approximately 95 % of the container. The containers must have water-tight closures.

5.20.1 Extraction vessels should be cleaned in a manner consistent with the analyses to be performed (see Section 13 of Practice **D3370**).

### 6. Reagents

6.1 *Purity of Reagents*—Reagent grade chemicals shall be used in all tests. Unless otherwise indicated, it is intended that

<sup>4</sup> Available from U.S. Government Printing Office, Washington, DC 20402. Request Publication Number 955-001-00000-1.

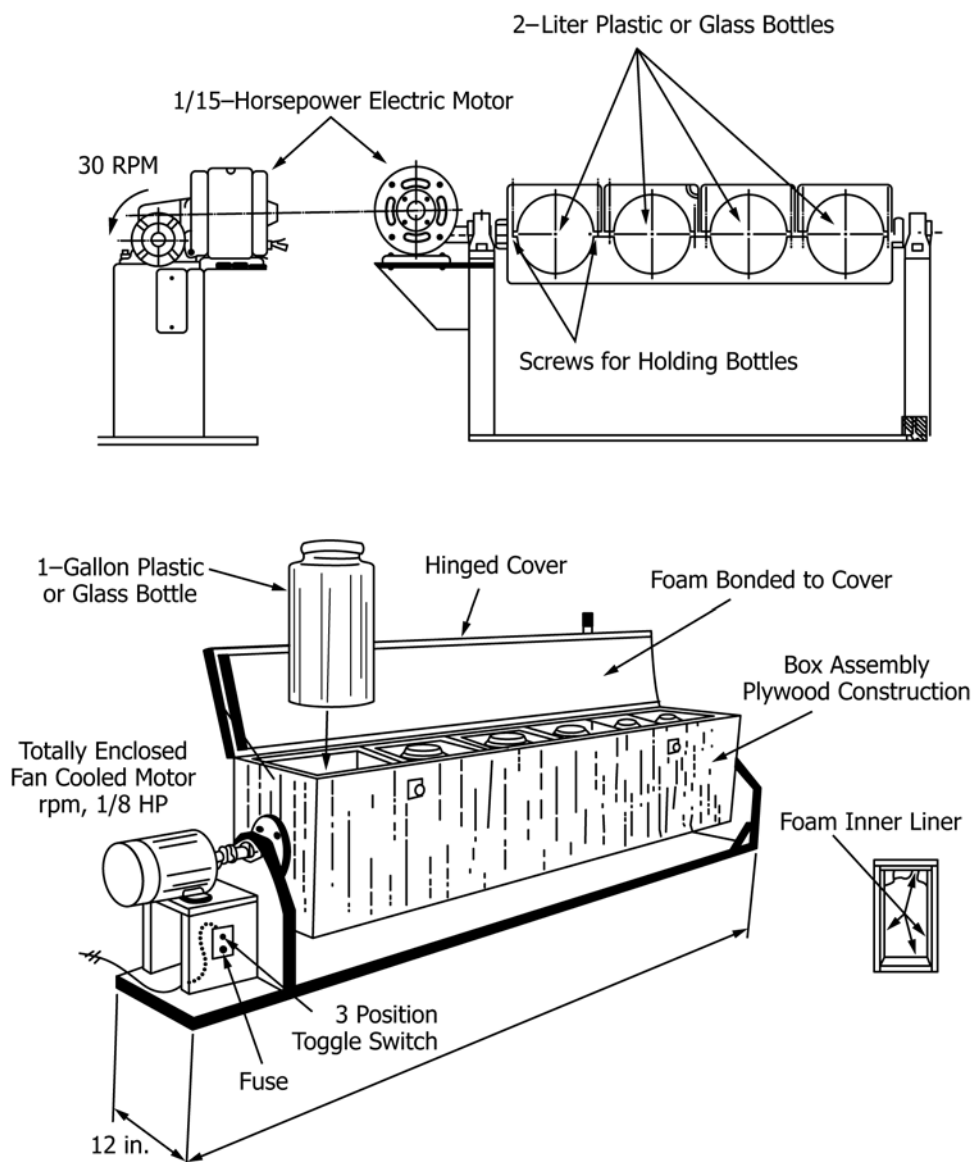

FIG. 1 Extractors

all reagents shall conform to the specifications of the Committee on Analytical Reagents of the American Chemical Society, where such specifications are available.<sup>5</sup> Other grades may be used, provided it is first ascertained that the reagent is of sufficiently high purity to permit its use without lessening the accuracy of the determination.

6.2 *Purity of Water*—Unless otherwise indicated, references to water shall be understood to mean Type IV reagent water at 18 to 27°C conforming to Specification **D1193**. The method by which the water is prepared, that is, distillation, ion exchange,

reverse osmosis, electrodialysis, or a combination thereof, should remain constant throughout testing.

6.3 *Sulfuric Acid/Nitric Acid Solution*—A 60/40 weight percent (weight %) mixture prepared using 95 to 98 weight % sulfuric acid and 69 to 71 weight % nitric acid. (See 9.3 for instructions on the preparation of this solution.)

## 7. Sampling

7.1 Obtain a representative sample of the mining waste to be tested by using, where available, ASTM sampling methods developed for the specific industry (see Practice **D75**, Guide **D420**, Terminology **D653**, Test Method **D2234/D2234M**, and Practice **E877**).

7.2 Sampling methodology for materials of similar physical form shall be used where no specific methods are available.

<sup>5</sup> *Reagent Chemicals, American Chemical Society Specifications*, American Chemical Society, Washington, DC. For suggestions on the testing of reagents not listed by the American Chemical Society, see *Analar Standards for Laboratory Chemicals*, BDH Ltd., Poole, Dorset, U.K., and the *United States Pharmacopeia and National Formulary*, U.S. Pharmacopeial Convention, Inc. (USPC), Rockville, MD.

7.3 The amount of sample to be sent to the laboratory should be sufficient to perform the solids content determination as specified in 9.2, and to provide 100 g of sample on a dry weight basis for extraction.

7.4 It is important that the sample of the mining waste be representative with respect to the inorganic constituents to be determined.

NOTE 4—Information on obtaining representative samples can also be found in Pierre Gy's *Sampling Theory and Sampling Practice*.<sup>6</sup>

7.5 In order to prevent sample contamination or constituent loss prior to extraction, keep the samples in closed containers appropriate to sample type and desired analysis. See Practices D3370 for guidance. Record the storage conditions and handling procedures in the report.

7.6 The time between collection and extraction of the sample should be determined by the nature of the sample and the information desired. See Practices D3370 for guidance. Report the length of time between sample collection and extraction. The user is advised to minimize the holding time between sampling and testing if the waste is suspected to contain reactive sulfide minerals (see Test Methods E1915). Sample containing reactive sulfide minerals may be preserved by filling the container with nitrogen gas and storing at 10°C.

## 8. Sample Preparation

8.1 Pass the gross sample through a 9.5-mm sieve and stage crush any oversize material no more than necessary to pass it through the sieve. Divide the gross sample in a riffle splitter with 25-mm chutes, repeatedly if necessary, to obtain a representative laboratory sample with a weight in the range of 250 to 500 g. Obtain a sample of the approximate size required in the test by quartering the sample received for testing on an impermeable sheet of glazed paper, oil cloth, or other flexible material having a composition suitable to the analytes of interest, as follows:

8.1.1 Empty the sample container into the center of the sheet.

8.1.2 Gently flatten the sample out with a suitable straightedge until it is spread uniformly to a depth at least twice the maximum particle diameter.

8.1.3 Remix the sample by lifting a corner of the sheet and drawing it low across to the opposite corner in such a manner that the material is made to roll over and over and does not merely slide along. Continue the operation with each corner, proceeding in a clockwise direction. Repeat this operation ten times.

8.1.4 Lift all four corners of the sheet toward the center and, holding all four corners together, raise the entire sheet into the air to form a pocket for the sample.

8.1.5 Repeat the procedure described in 8.1.2 to flatten the sample out.

8.1.6 With a straightedge (such as a thin-edged yardstick) at least as long as the flattened mound of sample, gently divide

the sample into quarters. Make an effort to avoid using pressure on the straightedge sufficient to cause damage to the particles.

8.1.7 Discard the alternate quarters.

8.1.8 If further reduction of the sample size is necessary, repeat the steps given in 8.1.3 through 8.1.7. Use a sample size to provide at least 100 g of solid on a dry weight basis. Provide additional samples for the determination of solids content (see 9.2). Use of a sample size less than 100 g of solid on a dry weight basis for extraction is not recommended; however, if a different sample size is used, report this fact.

NOTE 5—For other acceptable methods of mixing and subsampling free-flowing solid particulate wastes, see Pierre Gy's *Sampling Theory and Sampling Practice*.<sup>6</sup> The method of subsampling should be determined by the physical properties of the waste, analytes of interest, and equipment available.

## 9. Procedure

9.1 Record a physical description of the sample to be tested, including particle size so far as it is known.

9.2 *Solids Content*—Determine the solids weight fraction of two separate portions of the sample as follows:

9.2.1 Dry to a constant weight, at  $104 \pm 2^\circ\text{C}$ , two dishes or pans of size suitable to the solid waste being tested. Cool in a desiccator and weigh. Record the values to  $\pm 0.1$  g.

9.2.2 Place at least 50 g of the waste to be tested into each pan. Record the mass of sample in each pan to  $\pm 0.1$  g.

9.2.3 Dry for 16 to 20 h at  $104 \pm 2^\circ\text{C}$ . Record the temperature and time of the drying period.

9.2.4 Cool to room temperature in a desiccator and reweigh. Record the mass to  $\pm 0.1$  g.

9.2.5 Repeat the steps given in 9.2.3 and 9.2.4, if necessary, until constant container-sample masses are obtained. Record the final weights and discard the dried samples following completion of this step.

9.2.6 Calculate the solids weight fraction of the sample from the data obtained in 9.2.1, 9.2.2, and 9.2.4 as follows:

$$S = A/B \quad (1)$$

where:

A = mass of sample after drying, g,

B = original mass of sample, g, and

S = solids weight fraction, g/g.

Average the two values obtained. Record the solids weight fraction.

### 9.3 Preparation of Extraction Fluid:

9.3.1 *Acid Solution A*—Prepare 60/40 weight % mixture of sulfuric acid/nitric acid. Cautiously mix 60 g of concentrated sulfuric acid with 40 g of concentrated nitric acid. The preparation of this mixture should be performed in a laboratory fume hood.

9.3.2 *Acid Working Solution*—Add 1 mL of Acid Solution A (See 9.3.1) to 900 mL of water in a 1-L volumetric flask, dilute to the mark and mix (1/1000 solution).

9.3.3 *Extraction Fluid*—Using the acid working solution prepared in 9.3.2, prepare the extraction fluid having the desired  $\text{pH} \pm 0.05$  (see 4.2) by adding a volume of the Acid Working Solution into 2000 mL of water with mixing until the desired  $\text{pH} \pm 0.05$  is achieved. A recommended method for

<sup>6</sup> Pitard, F., *Pierre Gy's Sampling Theory and Sampling Practice*, 2nd Edition, CRC Press, Boca Raton, FL, 1993.

preparing the extraction fluid is to add 2000 mL of water to a 2-L Erlenmeyer flask equipped with a magnetic stir bar. Place the Erlenmeyer flask on magnetic stir plate, and add the Acid Working Solution to the flask with stirring. Stir the mixture vigorously, and measure its pH once the solution is static. Continue this process until the desired solution pH  $\pm 0.05$  is reached. Record amount of Acid Working Solution solution added. Record the pH value of the solution.

9.3.4 Additional 2-L batches of the extraction fluid can be prepared by mixing the volume of acid working solution determined in 9.3.3 with 2000 mL of water. The pH of the extraction fluid must be within  $\pm 0.05$  of the desired value for use in the extraction procedure.

9.3.5 *Bulk Extraction Solution Preparation*—For extracting different wastes requiring the same extraction fluid or performing replicate extractions, bulk extraction fluid can be prepared in a carboy-type container of a composition suitable to the nature of the analyses to be performed, using the Acid Working Solution volume determined in 9.3.3 for each 2 L volume of extraction fluid desired, and measured for correct pH. If the pH is within  $\pm 0.05$  of the desired value, extraction fluid portions may be dispensed from the carboy for use in the extraction procedure.

#### 9.4 Extraction Procedure:

9.4.1 *Test Sample*—Add at least 100 g (weighed to  $\pm 0.1$  g) of test sample on a dry weight basis to the extraction vessel. Calculate the minimum amount of as-received waste to add as follows:

$$M = 100/S \quad (2)$$

where:

$S$  = solids weight fraction (g/g) determined in 9.2.6, and  
 $M$  = minimum mass of as-received waste (weighed to  $\pm 0.1$  g) to add to the extraction vessel to yield at least 100 g of solid waste on a dry weight basis.

9.4.2 Calculate the dry test sample weight as follows:

$$M_d = MS \quad (3)$$

where:

$M_d$  = mass of dry test sample, g,  
 $S$  = solids weight fraction (g/g) determined in 9.2.6, and  
 $M$  = mass of test sample, g.

9.4.3 Calculate the mass of water in the test sample as follows:

$$M_w = M - M_d \quad (4)$$

where:

$M_w$  = mass of water in the test sample, g,  
 $M$  = mass of the test sample, g, and  
 $M_d$  = mass of the dry test sample, g.

9.4.4 The mass of the extraction fluid to add is twenty times the dry weight of the test sample and is calculated as follows:

$$M_e = 20M_d - M_w \quad (5)$$

where:

$M_e$  = mass of extraction fluid, g,  
 $M_d$  = mass of the dry test sample, g, and

$M_w$  = mass of water in the test sample, g.

This will provide a solid-to-liquid ratio of 1 to 20 in the extraction vessel.

9.4.5 Agitate at  $30 \pm 2$  r/min, continuously, for  $18 \pm 0.25$  h at 18 to 27°C. Samples which release gasses during agitation must be checked periodically and vented. Record the agitation time and temperature.

NOTE 6—The venting of the container and filtration have the potential to affect the concentration of volatile compounds in the extracts.

9.4.6 Open the extraction vessel. Observe and record any visible changes in the sample and leaching solution. Record the pH of the waste/leaching solution slurry.

9.5 *Filtration*—Quantitatively transfer as much of the waste/leaching solution as possible through a large glass funnel to a pressure filtration device equipped with a 0.45 or 0.8- $\mu$ m filter. Pressure filter the liquid through the filter using a compressed gas that will not contaminate or change the integrity of the sample in increments of 10 psi, increasing the pressure by 10 psi, only when extract is not expelled for a two minute interval. Do not exceed a maximum pressure of 50 psi. After the extract has passed through the filter, continue running gas through the filtration device at 30 psi for 3 min. The filtrate obtained is the extract mentioned in this test method (see 9.6). Determine the mass of the filtrate collected and report it as  $M_f$  for the extraction step. Measure the pH of the extract immediately, and then preserve the extract portions in a manner consistent with the chemical analyses or biological testing procedures to be performed (see Practices D3370, Section 15 and Test Method E2242, Extract).

NOTE 7—Analytical results may be affected by the type of filter used. If a 0.8  $\mu$ m filter pore size is used, the resulting extract should be digested prior to metals analysis. The composition of the filter should also be considered. If the filter is composed of material that may contaminate the extract during filtration, the filter should be washed in the filtration device in a manner consistent with the chemical analyses or biological testing procedures to be performed on the extract. For example, for elemental analysis of the extract, if a filter composed of borosilicate glass fiber is used, in order to prevent contamination, it should be washed in the filtration device with a dilute acid solution and rinsed with approximately 2 L of water prior to filtration.

NOTE 8—It is recommended that all filtrations be performed in a hood.

9.6 Analyze the extracts for specific constituents or properties, or use the extracts for biological testing procedures as desired, using appropriate ASTM or other appropriate standard test methods. Where no appropriate standard test methods exists, other appropriate test methods may be used and documented in the report. Whether visible phase separation during storage of the extracts occurs or not, appropriate

**TABLE 1 Statistical Summary**

Constituents	Mean, $\mu$ m/mL	Repeatability ( $r$ , Practice E691), $\mu$ g/mL	Reproducibility ( $R$ , Practice E691), $\mu$ g/mL
Barium	1.9	0.6	0.8
Calcium	1815	389	666
Lead	63	8	22
Magnesium	107	20	34
Manganese	36.7	5.6	15.4
Silicon	55	6	58
Zinc	297	87	98

mixing should be used to ensure the homogeneity of the extracts prior to their use in such analyses or testing.

## 10. Report

- 10.1 Report the following information:
- 10.2 Source of information concerning the pH value of the precipitation in the geographic region of interest;
- 10.3 Source of the waste, date of sampling, methods of sampling and sample preservation, storage conditions, handling procedures, and length of time between sample collection and extraction;
- 10.4 Description of the mining waste, including its physical characteristics and particle size, if known (See 9.1);
- 10.5 Solids weight fraction (See 9.2);
- 10.6 Mass of mining waste on a dry weight basis extracted;

- 10.7 The pH of the extraction fluid used for the extraction;
- 10.8 Time and temperature used in the determination of solids weight fraction;
- 10.9 Agitation temperature and time;
- 10.10 Filter pore size used and filter composition;
- 10.11 Use of a prefilter, prefilter pore size, and composition;
- 10.12 Observations of changes in the test material or leaching solution (see 9.4.6);
- 10.13 The pH before and after filtration, and the results of specific analyses; and
- 10.14 Dates on which extraction was started and completed, preservation used for extract portions, and dates of analyses.

NOTE 9—Fig. 2 presents a detailed laboratory worksheet that may be helpful in performing the test method.

### Sample Description:

#### Solids Weight Fraction Determination

Dish #1 mass after drying: = \_\_\_\_\_

Dish #2 mass after drying: = \_\_\_\_\_

Sample #1 mass before drying (B#1) : = \_\_\_\_\_

Sample #2 mass before drying (S#2) : = \_\_\_\_\_

Drying temperature: = \_\_\_\_\_

Drying time: = \_\_\_\_\_

Sample #1 mass after drying (A#1) : = \_\_\_\_\_

Sample #2 mass after drying (A#2) : = \_\_\_\_\_

Solids Weight Fraction #1 (S#1) :  $S = A\#1/B\#1 =$  \_\_\_\_\_

Solids Content #2 (S#2) :  $S = A\#2 \sim B\#2 =$  \_\_\_\_\_

Average Solids Weight Fraction (S) = \_\_\_\_\_

#### Extraction

Mass of test sample (M) :  $M - 100/S =$  \_\_\_\_\_

Dry mass of test sample ( $M_d$ ) :  $MS =$  \_\_\_\_\_

Mass of water in the test sample: ( $M_w$ ) :  $M - M_d =$  \_\_\_\_\_

Mass of extraction fluid ( $M_a$ ) :  $20M_d - M_w =$  \_\_\_\_\_

pH of extraction fluid: = \_\_\_\_\_

Extraction time and temperature: = \_\_\_\_\_

pH of Slurry: = \_\_\_\_\_

Filter type and pore size: = \_\_\_\_\_

Mass of filtrate collected ( $M_f$ ) : = \_\_\_\_\_

pH of extract: = \_\_\_\_\_

Observations:

**FIG. 2 Laboratory Worksheet**

## 11. Precision and Bias<sup>7</sup>

11.1 *Precision*—An interlaboratory study was undertaken to test the precision of the method in accordance with Practice **D2777** on two wastes from six data sets. The results from the mining waste sample tested in the study are summarized in **Table 1**. The within laboratory repeatability was measured using six analytical standards in triplicate. The between laboratory reproducibility was measured on the mining waste using a pH  $5.0 \pm 0.05$  synthetic precipitation extraction fluid.

11.2 The data generated in this collaborative study are specific to the test materials used in the study, the elements of

---

<sup>7</sup>Supporting data for the precision and bias information are available from ASTM Headquarters. Request PNC:33-00004-56.

interest to the study, the pH values of the extraction fluids used, and 0.45- $\mu\text{m}$  filter pore-size used for filtration. For other materials, elements, pH values, and filter types, these data may not apply.

11.3 *Bias*—Determination of the extraction bias of this test method is not possible, as no standard reference material exists. The analytical bias, however, was evaluated in the research report.

## 12. Keywords

12.1 extracts; extraction fluids; leaching procedure; mining waste; shake extraction; SPLP; synthetic precipitation; waste leaching technique

*ASTM International takes no position respecting the validity of any patent rights asserted in connection with any item mentioned in this standard. Users of this standard are expressly advised that determination of the validity of any such patent rights, and the risk of infringement of such rights, are entirely their own responsibility.*

*This standard is subject to revision at any time by the responsible technical committee and must be reviewed every five years and if not revised, either reapproved or withdrawn. Your comments are invited either for revision of this standard or for additional standards and should be addressed to ASTM International Headquarters. Your comments will receive careful consideration at a meeting of the responsible technical committee, which you may attend. If you feel that your comments have not received a fair hearing you should make your views known to the ASTM Committee on Standards, at the address shown below.*

*This standard is copyrighted by ASTM International, 100 Barr Harbor Drive, PO Box C700, West Conshohocken, PA 19428-2959, United States. Individual reprints (single or multiple copies) of this standard may be obtained by contacting ASTM at the above address or at 610-832-9585 (phone), 610-832-9555 (fax), or service@astm.org (e-mail); or through the ASTM website (www.astm.org). Permission rights to photocopy the standard may also be secured from the ASTM website (www.astm.org/COPYRIGHT/).*