



Standard Test Method for Determination of Cooling Characteristics of Quench Oils by Cooling Curve Analysis¹

This standard is issued under the fixed designation D6200; the number immediately following the designation indicates the year of original adoption or, in the case of revision, the year of last revision. A number in parentheses indicates the year of last reapproval. A superscript epsilon (ϵ) indicates an editorial change since the last revision or reapproval.

1. Scope

1.1 This test method describes the equipment and the procedure for evaluation of a quenching oil's quenching characteristics by cooling rate determination.

1.2 This test is designed to evaluate quenching oils in a non-agitated system. There is no correlation between these test results and the results obtained in agitated systems.

1.3 The values in SI units are to be regarded as the standard. The values in parentheses are provided for information only.

1.4 *This standard does not purport to address all of the safety concerns, if any, associated with its use. It is the responsibility of the user of this standard to establish appropriate safety and health practices and determine the applicability of regulatory limitations prior to use.*

2. Referenced Documents

2.1 *ASTM Standards*:²

D1744 Test Method for Determination of Water in Liquid Petroleum Products by Karl Fischer Reagent

E220 Test Method for Calibration of Thermocouples By Comparison Techniques

E230 Specification and Temperature-Electromotive Force (EMF) Tables for Standardized Thermocouples

2.2 *SAE Standards*:³

AMS 5665 Nickel Alloy Corrosion and Heat Resistant Bars, Forgings and Rings

2.3 *Japanese Industrial Standards (JIS)*:⁴

JIS K 2242 - 1980 Heat Treating Oil

JIS K 6753 - 1977 Di-2-ethylhexyl Phthalate

¹ This test method is under the jurisdiction of ASTM Committee D02 on Petroleum Products, Liquid Fuels, and Lubricants and is the direct responsibility of Subcommittee D02.L0.06 on Non-Lubricating Process Fluids.

Current edition approved April 15, 2012. Published May 2012. Originally approved in 1997. Last previous edition approved in 2007 as D6200-01(2007). DOI: 10.1520/D6200-01R12.

² For referenced ASTM standards, visit the ASTM website, www.astm.org, or contact ASTM Customer Service at service@astm.org. For *Annual Book of ASTM Standards* volume information, refer to the standard's Document Summary page on the ASTM website.

³ Available from Society of Automotive Engineers (SAE), 400 Commonwealth Dr., Warrendale, PA 15096-0001, <http://www.sae.org>.

⁴ Available from Japanese Standards Organization (JSA), 4-1-24 Akasaka Minato-Ku, Tokyo, 107-8440, Japan, <http://www.jsa.or.jp>.

3. Terminology

3.1 *Definitions of Terms Specific to This Standard:*

3.1.1 *cooling curve, n*—the cooling curve is a graphical representation of the cooling time (t) - temperature (T) response of the probe (see 7.3). An example is illustrated in Part B of Fig. 1.

3.1.2 *cooling curve analysis, n*—the process of quantifying the cooling characteristics of a heat treating oil based on the temperature versus time profile obtained by cooling a pre-heated metal probe assembly (see Fig. 2) under standard conditions.

3.1.3 *cooling rate curve, n*—The cooling rate curve is obtained by calculating the first derivative (dT/dt) of the cooling time - temperature curve. An example is illustrated in Part B of Fig. 1.

3.1.4 *heat treating oil, n*—a hydrocarbon containing product, often derived from petroleum base stock, that is used to mediate heat transfer between heated metal, such as austenitized steel, to control the microstructure that is formed upon cooling and also control distortion and minimize cracking which may accompany the cooling process.

3.1.5 *quench severity, n*—the ability of a quenching medium to extract heat from a hot metal.⁵

4. Summary of Test Method

4.1 Determine the nickel alloy probe assembly's cooling time versus temperature after placing the assembly in a furnace and heating to 850°C (1562°F) and then quenching in a heat treating oil. The temperature inside the probe assembly and the cooling times are recorded at selected time intervals to establish a cooling temperature versus time curve. The resulting cooling curve may be used to evaluate quench severity (see Note 1).

NOTE 1—For production testing, the furnace temperature of 815 to 857°C (1500 to 1575°F) may be used.

⁵ Boyer, H. E. and Cary, P. R., *Quenching and Distortion Control*, ASM International, Materials Park, OH, 1988, p. 162.

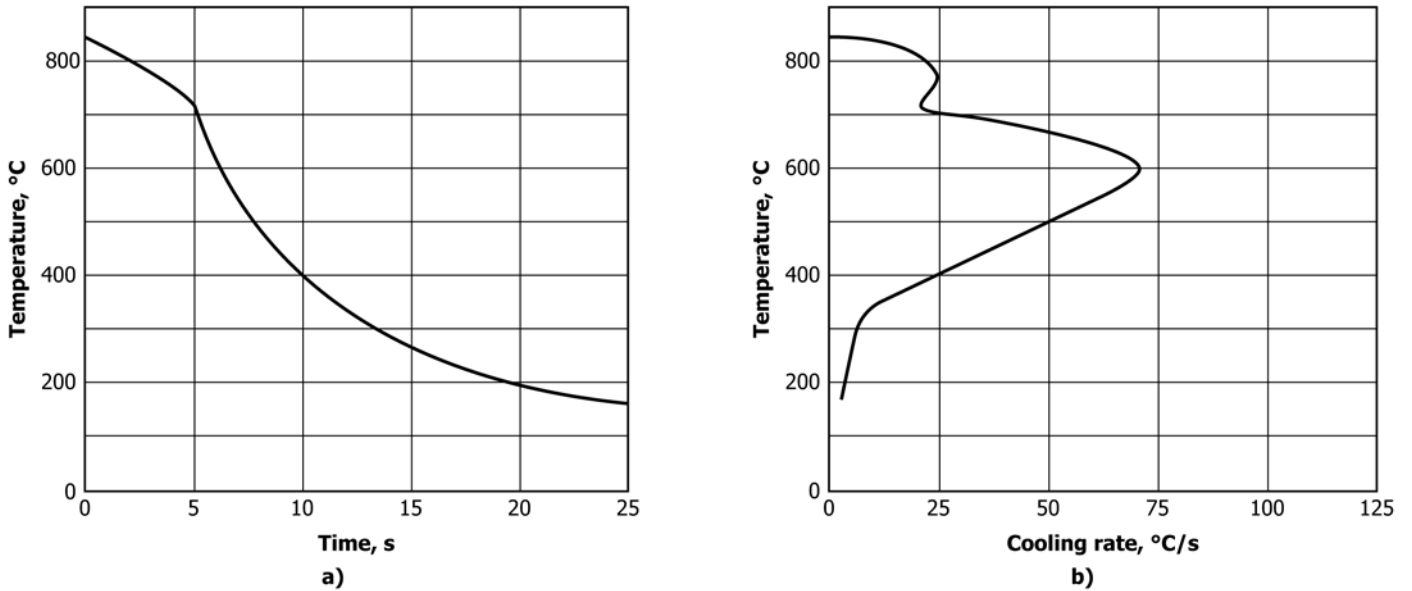
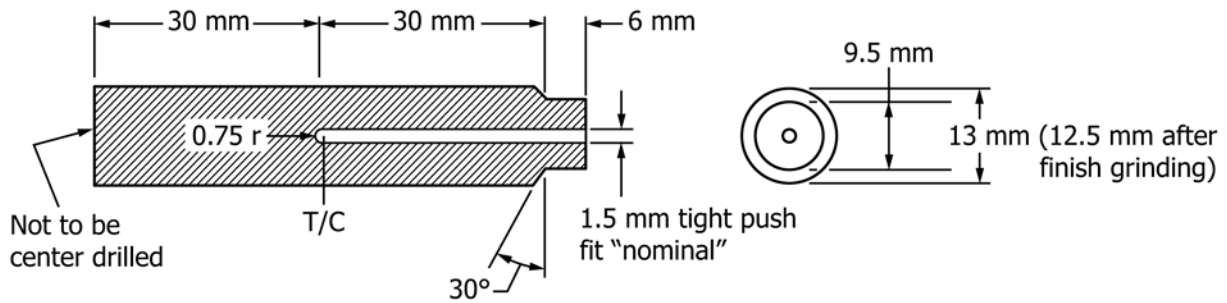
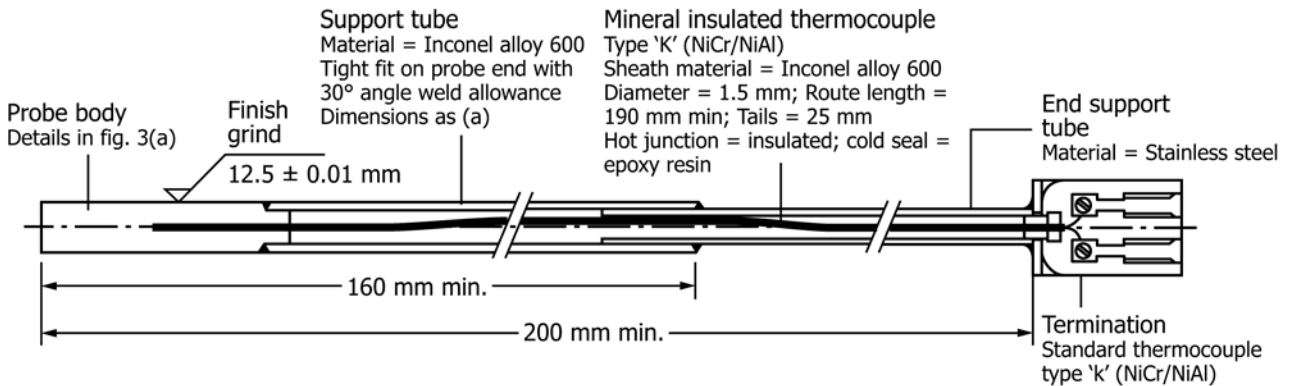

FIG. 1 Typical Temperature/Time and Temperature/Cooling Rate Plots For Test Probe Cooled in a Quenching Oil



(a) Probe details



(b) General assembly

FIG. 2 Probe Details and General Probe Assembly

5. Significance and Use

5.1 This test method provides a cooling time versus temperature pathway which is directly proportional to physical

properties such as the hardness obtainable upon quenching of a metal. The results obtained by this test may be used as a guide

in heat treating oil selection or comparison of quench severities of different heat treating oils, new or used.

6. Interferences

6.1 The presence of water in a heat treating oil has a major effect upon the results obtained with this test method. Water content of calibration fluids shall be confirmed by Test Method **D1744**. If water is present above 0.01 %, the calibration fluid shall be dried at a minimum temperature of 102°C (216°F) until Test Method **D1744** indicates water content at or below 0.01 %.

7. Apparatus

7.1 *Furnace*—Use a horizontal or vertical electrical resistance tube-type furnace capable of maintaining a constant minimum temperature of 850°C (1562°F) over a heated length of not less than 120 mm (4.72 in.) and a probe positioned in the center of the heating chamber. The furnace shall be capable of maintaining the probe's temperature within $\pm 2.5^\circ\text{C}$ (4.5°F) over the specimen length. The furnace, that is, the radiant tube heating media, shall be used with ambient atmosphere.

7.2 *Measurement System*—The temperature-time measurement system shall be a computer based data acquisition system capable of providing a permanent record of the cooling characteristics of each oil sample tested, producing a record of variation in the test probe assembly of temperature with respect to time, and cooling rate with respect to temperature.

7.3 *Probe*—The probe shall be cylindrical, having a diameter of 12.5 ± 0.01 mm (0.492 ± 0.0004 in.) and a length of 60 ± 0.25 mm (2.362 ± 0.01 in.) with a 1.45 to 1.65 mm (0.057 to 0.065 in.) sheathed Type K thermocouple in its geometric center. The probe shall be made of a nickel alloy 600 (UNS N06600) purchased to SAE Specification AMS 5665 which has a nominal composition of 76.0 % Ni, 15.5 % Cr, 8.0 % Fe, .08 % C, and .25 % max Cu. The probe shall be attached to a support tube with a minimum length of 200 mm (7.874 in.). The thermocouple sheathing and the support tube shall be the same material as the probe (see **Note 2**). See **Fig. 2** for recommended manufacturing details.

NOTE 2—Care must be taken that the probe specimen is not damaged as surface irregularities will influence the results of the test.

7.4 *Transfer Mechanism*—One of the following shall be used to transfer the heated probe from the furnace to the test fluid.

7.4.1 *Automated Transfer Mechanism*—The transfer from the furnace to the oil shall be completed within 3.0 s. Immerse the probe in the center, 0 to 5 mm (0 to 0.197 in.), of the heat treating oil container to a depth where there is 50 ± 2 mm (1.97 ± 0.08 in.) of fluid above and below the probe when quenched. A mechanical stop shall be used for reproducibility of probe placement.

7.4.2 *Manual Transfer*—If manual transfer is used, the sample container shall be equipped with a fixture to ensure correct placement in the center of the heat treating oil container and to the depth defined in 7.4.1. A timer shall be used to ensure a maximum transfer time of 3.0 s.

7.5 *Sample Container*—A container, preferably a damage-resistant, tall form vessel having an internal diameter of 115 ± 5 mm (4.528 ± 0.197 in.) shall be selected to provide 50 mL (1.97 in.) of fluid above and below the probe when quenched. It is recommended that 2000 ± 50 mL of oil be used. The resulting cooling curve will be dependent on the temperature rise during the quench and on the total fluid volume. Therefore, the cooling curve analysis shall be performed with the same volume of fluid.

7.6 *Oil Temperature Measurement*—Any temperature detection device may be used that is capable of measuring oil temperature to within $\pm 1^\circ\text{C}$ (1.8°F) during drying.

7.7 *Timer*—Graduated in seconds and minutes, and may be part of a computer clock.

8. Reagents and Materials

8.1 *Reference Quenching Fluid*—A reference quenching fluid shall be used for initial and regular system calibration. The primary reference fluid, as described in the Wolfson Engineering Group Specification⁶, exhibits the following cooling characteristics:

Time to cool to 600°C (1112°F)	12 - 14 s
Time to cool to 400°C (752°F)	19 - 21 s
Time to cool to 200°C (392°F)	50 - 55 s
Cooling rate, max	47 - 53°C/s (85-95°F/s)
Temperature of the maximum cooling rate	490 - 530°C (914-986°F)
Cooling rate at 300°C (572°F)	6 - 8°C/s (10.8-14.4°F/s)

8.1.1 These characteristics are based on quenching a 2000 ± 50 mL volume of the primary reference fluid in the sample container described in 7.5 according to the procedure outlined in Section 13.

8.1.2 A secondary reference fluid, such as JIS Standards K 2242 and K 6753, may be used, provided that sufficient statistical cooling curve testing has been conducted so that results are traceable to the six cooling characteristics of the primary reference fluid.

8.1.3 The reference fluids shall be stored in a sealed container when not in use and shall be replaced after 200 quenches or two years, whichever is sooner.

8.2 *Cleaning Solvent*—A hydrocarbon solvent that will evaporate at room temperature, leaving no residue (**Warning** - Flammable. Harmful if inhaled.).

8.3 *Polishing Paper*, 600 grit Emery.

8.4 *Cloth*, lintless and absorbent.

9. Cleaning and Conditioning

9.1 *Cleaning Used Probes*—Wipe probe with a lintless cloth or absorbent paper after removal from the oil and prior to returning to the furnace. (**Warning** —The probe shall always be considered hot, as temperature below visual hot temperatures can still cause injury to the skin (**Warning**—Do not use cleaning solvent near the furnace opening especially with automated transfer mechanisms.)) A cleaning solvent may be used, but care should be taken that the probe is below 50°C (122°F).

⁶ Available from Wolfson Heat Treatment Centre, Aston University, Aston Triangle, Birmingham B4 7ET, England.

9.2 *Conditioning New Probes*—Condition the probe prior to its initial use with any quenchant by carrying out a minimum of six trial quenches, or a greater number if required to achieve consistency, using a general purpose hydrocarbon oil. Consistency shall mean the last two tests shall have maximum cooling rates within $\pm 2\%$ in temperature and cooling rate. Clean the probe assembly between quenches as specified in 9.1. Quench the probe in the reference quenching fluid and check according to 12.3. If the probe does not meet the requirements of 12.3, recondition according to 9.3 and then recalibrate again according to 12.3. Do not use probes that do not meet these requirements.

9.3 *Probe Reconditioning*—The probe shall be reconditioned when the probe calibration according to 12.3 does not meet the calibration limits, of the reference fluid. Recondition the probe by cleaning with emery paper. Although coarser 320-grit paper may be used for initial cleaning, the final finish shall be provided using 600-grit emery paper. Following this surface cleaning procedure, the probe shall be quenched until repeatable cooling curve results of a reference oil are obtained.

9.3.1 An alternative is to recondition the probe after every run. Before testing a set of heat treating oils, the probe is quenched into the reference fluid after surface conditioning. If the results comply with the limits prescribed for the reference fluid, the probe may be used for further testing. When testing, the probe is cleaned prior to each run. After testing of the set of fluids is completed, the probe is quenched into the reference fluid to ensure that it is still within calibration.

10. Sampling

10.1 Sampling shall be in accordance with 7.5. Ensure the sample is representative of the oil being tested. A clean and dry sample container shall be used.

11. Preparation of Apparatus

11.1 Preheat furnace to $850 \pm 2^\circ\text{C}$ ($1562 \pm 4^\circ\text{F}$), (1500 to 1575°F).

11.2 Connect a dry, conditioned, calibrated probe to the transfer mechanism according to equipment manufacturer's instructions.

11.3 Heat fluid to the desired temperature, if production testing is being performed or to $40 \pm 1^\circ\text{C}$ ($104 \pm 1.8^\circ\text{F}$) if the reference quenching fluid is being tested. Continuously agitate the test sample when heating and remove stirring mechanism prior to start of test.

12. Calibration and Standardization

12.1 Probe:

12.1.1 Check the accuracy of the probe thermocouple by attaching a previously calibrated thermocouple to the outer surface of the probe. Locate the tip of the calibrated thermocouple 30 mm (1.181 in.) from the end of the probe. Heat the probe and calibrated thermocouple to the selected furnace temperature of $850 \pm 2^\circ\text{C}$ ($1562 \pm 4^\circ\text{F}$) and allow to equalize. Compare the outputs of both the furnace and probe thermocouples by any calibrated temperature measuring device capable of required accuracy as described in Specifications E220 and E230.

12.1.2 *Frequency of Probe Calibration*—Calibrate the probe against a reference quenching fluid before each set of test runs.

12.2 *Equipment Calibration*—Calibrate desired recording mechanism as described in Annex A1.

12.3 *Total System Calibration*—Calibrate the system with a reference quenching fluid (see 8.1) following the procedure described in Section 13. Calibrate the system prior to using a new probe for testing and before and after each new set of test runs. The limits of the results obtained on the reference fluid will be established for each reference fluid prior to use as described in 8.1. The limits shall include, as a minimum, the following values: maximum cooling rate ($^\circ\text{C/s}$, $^\circ\text{F/s}$), the temperature at the maximum cooling rate ($^\circ\text{C}$, $^\circ\text{F}$), cooling rate ($^\circ\text{C/s}$, $^\circ\text{F/s}$) at 300°C (572°F), and the time in seconds from immersion to three different temperatures such as: (a) 600°C (1112°F), (b) 400°C (752°F), and (c) 200°C (392°F). If the results deviate from the limits prescribed for each of the six cooling characteristics of the reference fluid (8.1), the system shall not be considered as being in calibration. The probe may need to be reconditioned (see 9.3). Alternatively, when results deviate from the prescribed limits, it is also appropriate to examine the test setup and procedure for compliance to this standard and the manufacturer's recommended practice.

13. Procedure

13.1 Place the probe in the preheated furnace. Bring the probe temperature to the required temperature of $850 \pm 2^\circ\text{C}$, ($1562 \pm 4^\circ\text{F}$) and soak at this temperature for at least 2 min.

13.2 Transfer the probe to the center of the quench oil sample activating the data collection equipment at the same time. (**Warning**—Electric resistance type furnaces may have to be turned off prior to the transfer from the furnaces to the sample when interference with the data collection device is noted.)

13.3 Hold the probe assembly without movement, with the mechanical transfer device or a holding fixture.

13.4 When the temperature of the probe has reached 200°C (392°F) or the desired lower temperature, remove it from the oil and clean as described in 9.1.

13.5 Run test in duplicate for reproducibility verification, using the same probe and the same sample of the oil returned to the same temperature prior to the start of the test. The final data that is reported may be averaged to produce the final cooling curve data or the results from both runs may be reported individually. Duplicate testing is not required when the cooling curves for oil being tested are essentially the same as that curve to which the test cooling curve is being compared.

14. Interpretation of Results

14.1 *Cooling Curves*—Cooling curves and cooling rate curves are obtained for comparison reasons, that is, the oil compared to another oil, a control sample, or previously recorded curves. The test may show the effect of oxidation, the presence of additives and their concentrations, or contamination on the cooling characteristics of a quenching oil. Changes in a quench oil's chemical or physical properties causes

changes in its heat extraction capabilities; either speeding up or slowing down part or all of the curve. See Fig. 1.

15. Report

15.1 The report shall include cooling time, temperature and cooling rate, and temperature curves for the submitted sample. Recommended data to be reported for each test run are provided in 15.1.1 through 15.1.3. Additional values shall be reported as required by the purchaser.

15.1.1 From the time/temperature graph, report the time to the nearest 0.1 s at 600°C (1112°F) 400°C (752°F), and 200°C (392°F).

15.1.2 From the temperature/cooling rate graph, report the following:

- 15.1.2.1 Maximum cooling rate °C/s (°F/s),
- 15.1.2.2 Temperature where the maximum cooling rate occurs (°C, °F), and
- 15.1.2.3 Cooling rate at 300°C (572°F).
- 15.1.3 Report the following information:
 - 15.1.3.1 Date,
 - 15.1.3.2 Identification of sample,
 - 15.1.3.3 Reference to the test method, and
 - 15.1.3.4 Cooling curves and cooling rate curves including calibration curves for the reference oil,
 - 15.1.3.5 Statement of results, and
 - 15.1.3.6 Any modifications to test methods, including, but not limited to, deviations in sample container shape, sample volume, and probe position.

16. Precision and Bias

16.1 Five cooperators tested five oils that represented the following ranges for the six primary cooling curve characteristics:

Maximum Cooling Rate	47 to 98°C/s
Temperature of the Maximum Cooling Rate	490 to 590°C
Cooling Rate at 300°C	5.8 to 33.4°C/s
Time to Cool to 600°C	8.6 to 13.4 s
Time to Cool to 400°C	11.2 to 22.5 s
Time to Cool to 200°C	27.2 to 59.7 s

The five cooperators verified the calibration of their units to the Primary Reference Quenching Fluid, see 8.1. The statistical analysis of data from this interlaboratory report can be obtained from ASTM Headquarters.⁷

16.2 The precision of this test method, as determined by statistical examination of interlaboratory test results in accordance with RR:D02-1007, is based on non-agitated quench oils that have been heated to 40°C. Additional variation may be encountered when testing oils at different temperatures:

16.2.1 *Repeatability*—The difference in successive results obtained by the same operator with the same apparatus under constant operating conditions in the same sample would, in the long run, in the normal and correct operation of the test method exceed the following deviation in one case in twenty:

Maximum Cooling Rate	2.1°C/s
Temperature of the Maximum Cooling Rate	12.7°C
Cooling Rate at 300°C	8.7 % of the mean
Time to Cool to 600°C	0.4 s
Time to Cool to 400°C	0.5 s
Time to Cool to 200°C	1.3 s

16.2.2 *Reproducibility*—The difference between two single and independent results obtained by different operators working in different laboratories on identical test specimens would, in the long run, exceed the following in only one case in twenty:

Maximum Cooling Rate	8.6°C/s
Temperature of the Maximum Cooling Rate	25.3°C
Cooling Rate at 300°C	25 % of the mean
Time to Cool to 600°C	1.4 s
Time to Cool to 400°C	2.1 s
Time to Cool to 200°C	10.1 s

16.3 *Bias*—The evaluation of cooling characteristics of quench oils by this test method has no bias because the cooling characteristics can be defined only in terms of this test method.

17. Keywords

17.1 cooling curve; cooling rate; cooling time; quench oil

⁷ Supporting data have been filed at ASTM International Headquarters and may be obtained by requesting Research Report RR:D02-1489.

ANNEX

(Mandatory Information)

A1. EQUIPMENT CALIBRATION

A1.1 Computer

A1.1.1 Using a potentiometer, supply an emf to the sheathed Type K ungrounded thermocouple leadwire or connector to the following equivalents:

200°C (392°F)
500°C (932°F)
850°C (1562°F)

A1.1.2 The resultant readout on the system should be ± 2.25 % of the emf's equivalent temperature. See Specification E230.

A1.1.3 The time axis of the data collection system shall be checked by a stopwatch at the commencement of each series of tests, but not to exceed 50 tests. The error shall not exceed 0.5 %.

A1.2 Data Acquisition and Plotting

A1.2.1 The probe thermocouple output is sampled, digitized and stored in the memory of the computer. The Type K thermocouple leadwire shall have an electronic zero reference junction in the hookup. The frequency of sample data point

collection should not be less than 5 times per second (sample period of 125 milliseconds or less) and the data collection time should be 60 s or greater.

A1.2.2 The temperature-time plot may be produced either on-line during the test or off-line after the test.

A1.2.3 The cooling rate is calculated by numerical differentiation of the probe thermocouple output temperature. The cooling rate shall be calculated by a software program in the microprocessor or from a disc. The overall accuracy of the measurement system shall not exceed the limits of 12.3.

ASTM International takes no position respecting the validity of any patent rights asserted in connection with any item mentioned in this standard. Users of this standard are expressly advised that determination of the validity of any such patent rights, and the risk of infringement of such rights, are entirely their own responsibility.

This standard is subject to revision at any time by the responsible technical committee and must be reviewed every five years and if not revised, either reapproved or withdrawn. Your comments are invited either for revision of this standard or for additional standards and should be addressed to ASTM International Headquarters. Your comments will receive careful consideration at a meeting of the responsible technical committee, which you may attend. If you feel that your comments have not received a fair hearing you should make your views known to the ASTM Committee on Standards, at the address shown below.

This standard is copyrighted by ASTM International, 100 Barr Harbor Drive, PO Box C700, West Conshohocken, PA 19428-2959, United States. Individual reprints (single or multiple copies) of this standard may be obtained by contacting ASTM at the above address or at 610-832-9585 (phone), 610-832-9555 (fax), or service@astm.org (e-mail); or through the ASTM website (www.astm.org). Permission rights to photocopy the standard may also be secured from the Copyright Clearance Center, 222 Rosewood Drive, Danvers, MA 01923, Tel: (978) 646-2600; <http://www.copyright.com/>