



Standard Test Methods for Loop Tack¹

This standard is issued under the fixed designation D6195; the number immediately following the designation indicates the year of original adoption or, in the case of revision, the year of last revision. A number in parentheses indicates the year of last reapproval. A superscript epsilon (ϵ) indicates an editorial change since the last revision or reapproval.

1. Scope

1.1 These test methods cover the determination of properties of a pressure-sensitive adhesive. These test methods are applicable to those adhesives that form a bond of measurable strength rapidly upon contact with another surface. Tack force may be measured as the force required to separate the adhesive from the adherend at the interface shortly after they have been brought into contact under a load equal only to the weight of the pressure-sensitive article (for example, tape, label, sticker, etc.) on a 1 in.² contact area.

1.2 The following test methods are included:

1.2.1 *Test Method A* (using Tensile Tester), and

1.2.2 *Test Method B* (using Loop Tack Tester).

1.3 The values stated in inch-pound units are to be regarded as the standard because the industry standard width for pressure-sensitive tape is 1 inch. The values given in parentheses are mathematical conversions to SI units that are provided for information only and are not considered standard.

1.4 *This standard does not purport to address all of the safety concerns, if any, associated with its use. It is the responsibility of the user of this standard to establish appropriate safety and health practices and determine the applicability of regulatory limitations prior to use.*

2. Referenced Documents

2.1 *ASTM Standards:*²

[A666 Specification for Annealed or Cold-Worked Austenitic Stainless Steel Sheet, Strip, Plate, and Flat Bar](#)

[D907 Terminology of Adhesives](#)

[D2651 Guide for Preparation of Metal Surfaces for Adhesive Bonding](#)

[E4 Practices for Force Verification of Testing Machines](#)

[E171 Practice for Conditioning and Testing Flexible Barrier Packaging](#)

¹ These test methods are under the jurisdiction of ASTM Committee D10 on Packaging and are the direct responsibility of Subcommittee D10.14 on Tape and Labels.

Current edition approved April 1, 2011. Published April 2011. Originally approved in 1997. Last previous edition approved in 2003 as D6195 – 03^{ε1}. DOI: 10.1520/D6195-03R11.

² For referenced ASTM standards, visit the ASTM website, www.astm.org, or contact ASTM Customer Service at service@astm.org. For *Annual Book of ASTM Standards* volume information, refer to the standard's Document Summary page on the ASTM website.

[E177 Practice for Use of the Terms Precision and Bias in ASTM Test Methods](#)

[E691 Practice for Conducting an Interlaboratory Study to Determine the Precision of a Test Method](#)

2.2 *European Association for the Pre-Adhesed Labeling Industry (FINAT) Standard:*³

[FTM 9 “Quick-Stick” Tack Measurement](#)

2.3 *Tag and Label Manufacturers Institute, Inc. (TLMI) Standard:*⁴

[L-IB1 TLMI Loop Tack Test](#)

[L-IB2 Tensile Tester Loop Tack Test](#)

3. Terminology

3.1 *Definitions:*

3.1.1 Many of the terms found in these test methods are defined in Terminology [D907](#).

4. Summary of Test Method

4.1 These test methods involve allowing a loop of pressure-sensitive adhesive with its backing to be brought into controlled contact with a 1 in.² (25 by 25 mm) surface of stainless steel, with the only force applied being the weight of the pressure-sensitive article itself. The pressure-sensitive article is then removed from the substrate, with the force to remove the pressure-sensitive article from the adherend measured by a recording instrument.

4.2 *Test Method A* (using a Tensile Tester) applies when a Tensile Tester is used to measure loop tack and involves the use of a loop prepared from an 7 in. (175 mm) specimen strip.

4.3 *Test Method B* (using a Loop Tack Tester) applies when a Loop Tack Tester is used to measure loop tack and involves the use of a loop prepared from a 5 in. (125 mm) specimen strip.

5. Significance and Use

5.1 These test methods provide a quantitative measure of the pressure-sensitive tack property of an adhesive.

³ Available from FINAT, Laan Copes Van Cattenburch 79, 2585 EW, The Hague, Holland.

⁴ Available from TLMI, 40 Shuman Blvd., Ste. 295, Naperville, IL 60563.

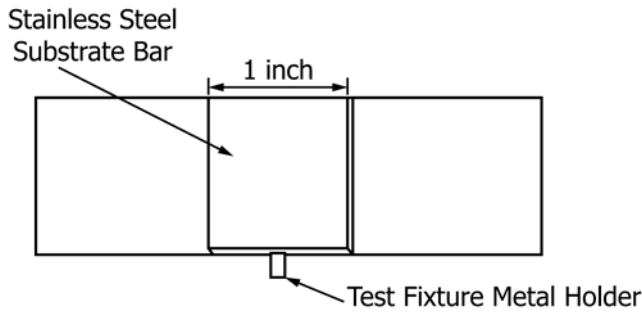

FIG. 1 Loop Tack Test Fixture 1

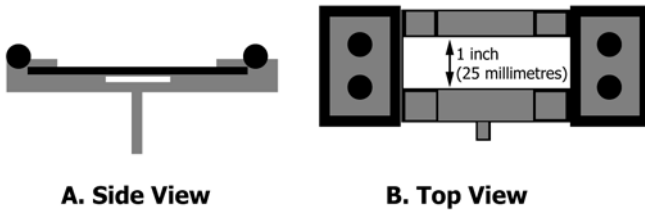

FIG. 2 Loop Tack Test Fixture 2

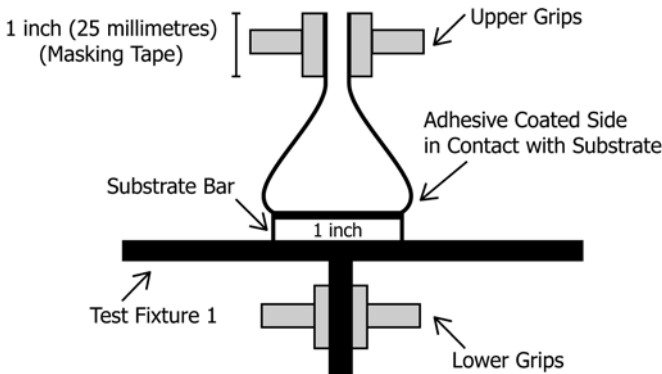

FIG. 3 Loop Tack Sample During Test

5.2 These test methods are designed to measure the tack property of the adhesive mass. The tack of a given adhesive varies depending on the backing (generally, stiffer backings lead to higher values).

5.3 These test methods are suitable for quality control and research purposes.

5.4 *Test Method A* (using Tensile Tester) makes use of a specimen strip 7 in. (175 mm) in length. Both the FINAT FTM 9 “Quick Stick” Tack Measurement Test and the TLMI L-IB2 Tensile Tester Loop Tack Test also use a specimen strip of that length.

5.5 *Test Method B* (using Loop Tack Tester) makes use of a specimen strip five in. (125 mm) in length. That is the only length specimen strip that fits properly in the loop tack tester.

5.6 If the adhesive is not already otherwise coated, these test methods incorporate the use of a clear 2 mil (0.05 mm) polyester (PET) film backing for specimen preparation. Use of other backing materials changes performance of the specimen to be tested.

TEST METHOD A (Using a Tensile Tester)

6. Apparatus

6.1 *Tensile Tester*—A constant rate of extension type.

6.2 *Test Fixture* (Fig. 1 or Fig. 2⁵)—To be mounted into the jaws of the tensile tester. A panel held by the test fixture allows for a 1 in.² (25 by 25 mm) contact area of the pressure-sensitive article. Alternately, the test fixture may include a raised area that allows a 1 in.² (25 by 25 mm) contact area of the pressure-sensitive article.

6.2.1 The panel or the raised area of the test fixture is stainless steel as specified in Specification A666.

6.3 *Apparatus for Cutting*:

6.3.1 *Die Cutter*—A 1 by 7 in. (25 by 175 mm) rectangular mallet-type die cutter with mallet for sample preparation.

6.3.2 If a fixed dimension die is unavailable, substitute a 1-in. (25-mm) steel bar with a double razor knife or other apparatus suitable for cutting the specimen into the specified dimensions to prepare the 1 in. (25 mm) wide specimen strips.

6.4 *Absorbent Lint-Free Cleaning Material*—Materials produced from entirely virgin raw materials and containing less than 0.25 % by weight of solvent-leachable materials.

6.5 *Masking Tape*—1 in. (25 mm) wide.

6.6 2 mil (0.05 mm) PET Film—To be used as a support medium in evaluating unsupported adhesives such as transfer tapes, laminating adhesives, or other free-film adhesives.

6.7 *Reagents*—Appropriate reagents include acetone, diacetone alcohol, n-heptane and toluene, reagent or analytical grade, or an ethanol cleaner for water-based adhesives.

7. Sample Preparation

7.1 Cut sample into 1 by 7 in. (25 by 175 mm) specimen strips in the machine direction (when known) of the pressure-sensitive article. Use of strips of other lengths may change results. Cut at least three specimen strips for each adhesive to be tested.

NOTE 1—If transfer or unsupported adhesives are to be tested, these are to be laminated to 2 mil (0.05 mm) PET film, used as an adhesive support, prior to cutting the samples into the 1 by 7 in. (25 by 175 mm) specimen strips.

7.2 Condition specimens to be tested for at least 24 h in a testing room at $73.4 \pm 3.6^{\circ}\text{F}$ ($23 \pm 2^{\circ}\text{C}$) and a relative humidity of $50 \pm 5\%$, in accordance with Specification E171, prior to conducting the test.

8. Conditioning

8.1 *Testing Room*—Test in a standard laboratory atmosphere, at $73.4 \pm 3.6^{\circ}\text{F}$ ($23 \pm 2^{\circ}\text{C}$) and a relative humidity of $50 \pm 5\%$, in accordance with Specification E171.

9. Procedure

9.1 Ensure that the tensile tester is calibrated according to instructions supplied by the manufacturer and conforming to the requirements of Practices E4.

⁵ Available from Chem Instruments, 510 Commercial Drive, Fairfield, OH 45014-7593.

9.2 Set the instrument crosshead speed at 12 in. (300 mm)/min.

9.3 Place the test fixture in the lower grip of the tensile tester. It is important that the test fixture be level and straight in the lower grip. See Fig. 1, Fig. 2 and Fig. 3.

9.4 Set gaps for the crosshead using the minimum and maximum gap setting on the extension cycle. Set gaps 1 ± 0.05 in. (25 ± 1 mm) (critical) and 4 ± 0.1 in. (100 ± 3 mm) (optional) from the bottom of the upper grips to the face of the stainless steel portion of the test fixture when the test fixture is locked in the lower grips. Set the chart recorder speed for 2 in. (50 mm)/min. Set the chart recorder load scale to 20 lb (90 N) full scale.

9.5 Clean the stainless steel portion of the test fixture (the area the pressure-sensitive article will contact) prior to use using reagent(s) from 6.7. Use absorbent, lint-free cleaning material. Use a separate piece of cleaning material each time. Repeat for a total of three washes after the test fixture appears clean. Allow 2 min to elapse after cleaning to ensure complete evaporation of the cleaning solvent. The user must ensure that the cleaning method used removes all residue from the test fixture. The water-break test, described in Guide D2651, may be used to verify cleanliness.

9.6 Completely remove the release liner (if the pressure-sensitive article normally includes a release liner) from the specimen.

9.7 Bend the specimen completely back on itself, being careful not to crease it. The specimen forms a tear drop shaped loop with the adhesive surface facing out.

9.8 Fasten the ends of the loop together, using a strip of masking tape 1 in. (25 mm) wide (Fig. 4). The masking tape covers the ends of the loop, preventing contamination of the grips of the tensile tester.

9.9 Insert the taped end of the specimen loop into the upper grips so that the bottom edge of the masking tape is even with the bottom edges of the grips.

9.10 Turn on the chart recorder. Activate the tensile tester so that the crosshead moves downward. The mid-section of the specimen loop must contact the center of the stainless steel portion of the test fixture. When the crosshead reaches its minimum position, it will immediately switch direction and

move upward. When the crosshead is at its minimum position, the specimen loop will completely cover the 1 in. (25 mm) area of the stainless steel portion of the test fixture without excessive “hang-over” of the edges.

NOTE 2—If the tensile tester does not have automatic cycling, cycling must be done manually.

9.11 Record the maximum force required to remove the specimen loop from the stainless steel portion of the test fixture as well as the mode of failure.

9.11.1 Record the failure mode as adhesion, cohesion or transfer.

9.12 Repeat procedure (9.5 to 9.11.1) at least two additional times for each adhesive to be tested (for a minimum of three replicates). Use a fresh specimen strip for each test.

9.13 When testing is complete, clean the stainless steel portion of the test fixture with approved reagent. Cover with masking tape when not in use to protect the surface from scratches.

TEST METHOD B (Using a Loop Tack Tester)

10. Apparatus

10.1 *Loop Tack Tester* (Fig. 5)⁵, also used in TLMI Test L-IB1.

10.2 *Stainless Steel Test Panels*—1 in. (25 mm) by 6 in. (150 mm), stainless steel as specified in Specification A666.

10.3 *Apparatus for Cutting.*

10.3.1 *Die Cutter*—A 1 by 5 in. (25 by 125 mm) rectangular mallet-type die cutter with mallet for sample preparation.

10.3.2 If a fixed dimension die is unavailable, substitute a 1 in. (25-mm) steel bar with a double razor knife or other apparatus suitable for cutting the specimen into the specified dimensions to prepare the 1 in. (25 mm) wide specimen strips.

10.4 *Absorbent Lint-Free Cleaning Material*—Materials produced from entirely virgin raw materials and containing less than 0.25 % by weight of solvent-leachable materials.

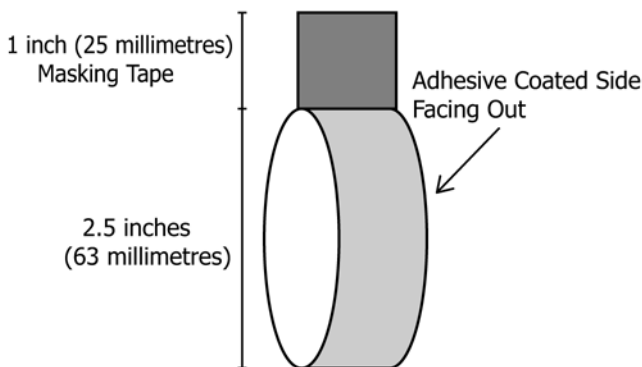

FIG. 4 Specimen Loop - Test Method A

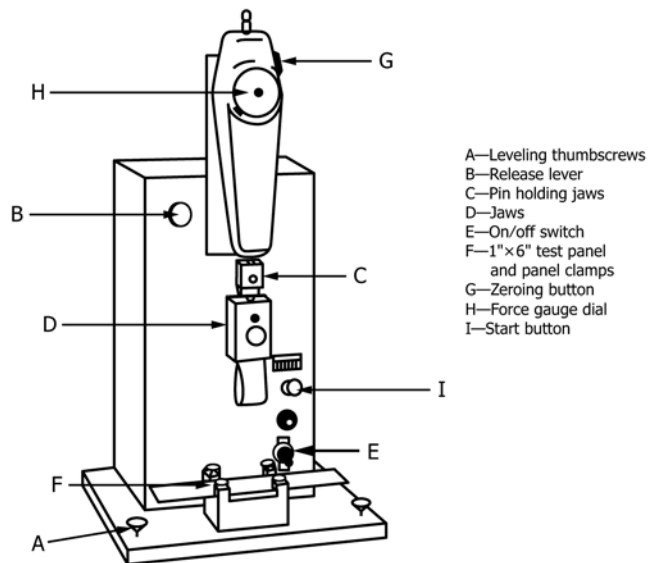

FIG. 5 Loop Tack Tester

10.5 *Masking Tape*—0.5 in. (12.5 mm) wide.

10.6 *2 mil (0.05 mm) PET Film*—To be used as a support medium in evaluating unsupported adhesives such as transfer tapes, laminating adhesives, or other free-film adhesives.

10.7 *Reagents*—Appropriate reagents include acetone, diacetone alcohol, n-heptane and toluene, reagent or analytical grade, or an ethanol cleaner for water-based adhesives.

11. Sample Preparation

11.1 Cut the sample into 1 by 5 in. (25 by 125 mm) specimen strips in the machine direction (when known) of the pressure-sensitive article. Use of strips of other lengths may change results and will not fit properly in the loop tack tester. Cut at least three specimen strips for each adhesive to be tested.

NOTE 3—If transfer or unsupported adhesives are to be tested, these are to be laminated to 2 mil (0.05 mm) PET film, used as an adhesive support, prior to cutting the samples into the 1 by 5 in. (25 by 125 mm) specimen strips.

11.2 Condition the specimens to be tested for at least 24 h in the testing room at $73.4 \pm 3.6^{\circ}\text{F}$ ($23 \pm 2^{\circ}\text{C}$) and a relative humidity of $50 \pm 5\%$, in accordance with Specification E171, prior to conducting the test.

12. Conditioning

12.1 *Testing Room*—Test in a standard laboratory atmosphere, at $74.3 \pm 3.6^{\circ}\text{F}$ ($23 \pm 2^{\circ}\text{C}$) and a relative humidity of $50 \pm 5\%$, in accordance with Specification E171.

13. Procedure

13.1 Ensure that the loop tack tester is leveled and connected to electrical power. Release the upper assembly locking lever (Fig. 5(B)).

13.2 Turn the power switch (Fig. 5(E)) to “ON.”

13.3 Ensure that the grip is in its upward-most position.

13.4 Remove the stainless steel test panel by loosening the four clamp screws (Fig. 5(F)).

13.5 Clean the stainless steel panel prior to use using reagent(s) from 10.7. Use a separate piece of cleaning material each time. Repeat for a total of three washes after the test panel appears clean. Allow 2 min to elapse after cleaning to ensure complete evaporation of the cleaning solvent. The user must ensure that the cleaning method used removes all residue from the test fixture. The water-break test, described in Guide D2651, may be used to verify cleanliness.

13.6 Reinsert the test panel and tighten the four clamp screws.

13.7 Completely remove the release liner (if the pressure-sensitive article normally includes a release liner) from the specimen.

13.8 Bend the specimen completely back on itself, being careful not to crease it. The specimen forms a tear drop shaped loop with the adhesive surface facing out (Fig. 6).

13.9 Fasten the ends of the specimen loop together, using a strip of masking tape 0.5 in. (12.5 mm) wide.

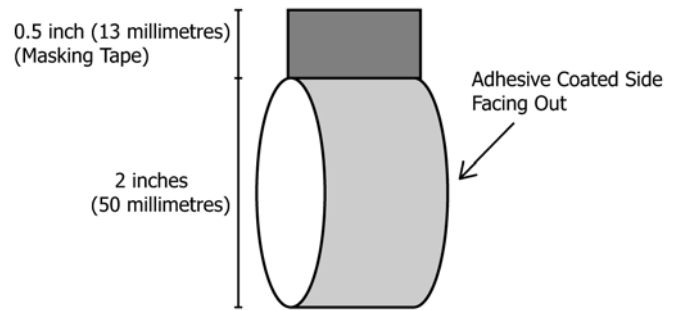

FIG. 6 Specimen Loop - Test Method B

13.10 Insert the specimen loop into the specimen jaw until it touches the guide pins near the center of the jaw. Inserting the specimen loop in this way ensures that it is positioned properly.

13.11 Zero the force gage according to instructions provided by the manufacturer and Practices E4.

13.12 Press the “Start” button (Fig. 5(I)) and keep it depressed until the upper assembly starts to move downward. The upper assembly will complete one full cycle and automatically shut off when the force gage again reaches its starting position.

13.12.1 This cycle will first move the upper assembly downward, bringing the specimen loop into contact with the test surface, forming a bond.

13.12.2 The assembly will then move upward and the force gage measures the force required to break the bond.

13.12.3 The cycle will end when the assembly returns to its original starting position.

13.13 Record the maximum force required to remove the specimen loop from the stainless steel panel as well as the mode of failure.

13.13.1 Record failure mode as adhesion, cohesion or transfer.

13.14 Repeat procedure (13.13 to 13.13.1) at least two additional times for each adhesive to be tested (for a minimum of three replicates). Use a fresh specimen strip for each test.

13.15 When testing is complete, clean the stainless steel panel with approved reagent. Cover with masking tape when not in use to protect surface from scratches.

14. Calculation

14.1 Calculate the average peak reading in pounds (Newtons) and the standard deviation using at least three specimens for each adhesive.

15. Report

15.1 Report the following:

15.1.1 Test Method (A or B),

15.1.2 Identification of the adhesive,

15.1.3 Reagent(s) and method used for cleaning the stainless steel portion of the test fixture,

15.1.4 Conditioning time for prepared specimens,

15.1.5 Adhesive type and coating thickness in mils (millimetres),

TABLE 1 Loop Tack Precision Data (Test Method A)

Material	Average (lb/in ²)	Repeatability Standard Deviation	Reproducibility Standard Deviation	Repeatability Limit	Reproducibility Limit
A	1.1327	0.1299	0.3225	0.3637	0.9030
B	1.8988	0.1622	0.2710	0.4541	0.7587
C	2.1005	0.3027	0.4893	0.8477	1.3699
D	5.7730	0.3394	0.6908	0.9502	1.9343

TABLE 2 Loop Tack Precision Data (Test Method B)

Material	Average (lb/in ²)	Repeatability Standard Deviation	Reproducibility Standard Deviation
A	1.154	0.0690	0.1880
B	2.044	0.1660	0.3167
C	2.256	0.3116	0.5681
D	6.548	0.2741	0.6283

- 15.1.6 Backing material used for the adhesive,
- 15.1.7 Release liner used, if any,
- 15.1.8 Crosshead speed of the tensile tester (Test Method A only),
- 15.1.9 Temperature and humidity conditions,
- 15.1.10 Average peak reading in pounds (Newtons),
- 15.1.11 Standard deviation of peak readings,
- 15.1.12 Visual mode of failure (adhesion, cohesion or transfer), and
- 15.1.13 Length of specimen strip in inches (millimetres).

16. Precision and Bias⁶

16.1 An interlaboratory study of loop tack precision by Test Method A was conducted in accordance with Practice E691. Seven laboratories reported three test results on each of four adhesive tapes. The four adhesive tapes represented different

⁶ Supporting data have been filed at ASTM International Headquarters and may be obtained by requesting Research Report RR:D14-1007.

ASTM International takes no position respecting the validity of any patent rights asserted in connection with any item mentioned in this standard. Users of this standard are expressly advised that determination of the validity of any such patent rights, and the risk of infringement of such rights, are entirely their own responsibility.

This standard is subject to revision at any time by the responsible technical committee and must be reviewed every five years and if not revised, either reapproved or withdrawn. Your comments are invited either for revision of this standard or for additional standards and should be addressed to ASTM International Headquarters. Your comments will receive careful consideration at a meeting of the responsible technical committee, which you may attend. If you feel that your comments have not received a fair hearing you should make your views known to the ASTM Committee on Standards, at the address shown below.

This standard is copyrighted by ASTM International, 100 Barr Harbor Drive, PO Box C700, West Conshohocken, PA 19428-2959, United States. Individual reprints (single or multiple copies) of this standard may be obtained by contacting ASTM at the above address or at 610-832-9585 (phone), 610-832-9555 (fax), or service@astm.org (e-mail); or through the ASTM website (www.astm.org). Permission rights to photocopy the standard may also be secured from the Copyright Clearance Center, 222 Rosewood Drive, Danvers, MA 01923, Tel: (978) 646-2600; http://www.copyright.com/

adhesive chemistries as well as different levels of loop tack. For this study, a specimen length of 8 in. was used rather than the 7 in. specified in the test method. Similar precision results are expected with a 7 in. specimen. Results of the repeatability study are summarized in Table 1.

16.2 The precision information given below was calculated for the comparison of the average of three individual test determinations as specified in Test Method A.

16.3 The terms repeatability limit and reproducibility limit are used as specified in Practice E177.

16.4 Repeatability:

16.4.1 The repeatability of this test method was an increasing function of the value of the test result. See Table 1.

16.5 Reproducibility:

16.5.1 The reproducibility of this test method was an increasing function of the value of the test result. See Table 1.

16.6 For Test Method B, three laboratories reported results on each of four adhesive tapes. Although the tapes were sent to eight laboratories, only three of them had access to a commercial loop tack tester. The commercial loop tack tester uses a 5 in. test specimen. With so few test results, the standard deviations are probably underestimated. Repeatability and reproducibility standard deviation were determined accordance with Practice E691.

16.7 Repeatability:

16.7.1 The repeatability of this test method was an increasing function of the value of the test result. See Table 2.

16.8 Reproducibility:

16.8.1 The reproducibility of this test method was an increasing function of the value of the test result. See Table 2.

17. Keywords

17.1 adhesive; loop tack; pressure-sensitive article; tack