



# Standard Test Method for Glow-Wire Ignition of Materials<sup>1</sup>

This standard is issued under the fixed designation D6194; the number immediately following the designation indicates the year of original adoption or, in the case of revision, the year of last revision. A number in parentheses indicates the year of last reapproval. A superscript epsilon ( $\epsilon$ ) indicates an editorial change since the last revision or reapproval.

## 1. Scope\*

1.1 This test method covers the minimum temperature required to ignite insulating materials using a glowing heat source. In a preliminary fashion, this test method differentiates between the susceptibilities of different materials with respect to their resistance to ignition due to an electrically-heated source.

1.2 This test method applies to molded or sheet materials available in thicknesses ranging from 0.25 to 6.4 mm.

1.3 This test method is not valid for determining the ignition behavior of complete electrotechnical equipment, since the design of the electrotechnical product influences the heat transfer between adjacent parts.

1.4 This test method measures and describes the response or materials, products, or assemblies to heat and flame under controlled conditions, but does not by itself incorporate all factors required for fire hazard or fire risk assessment of the materials, products, or assemblies under actual fire conditions.

1.5 The values stated in SI units are to be regarded as standard. No other units of measurement are included in this standard. (See [IEEE/ASTM SI-10](#) for further details.)

1.6 *This standard does not purport to address all of the safety concerns, if any, associated with its use. It is the responsibility of the user of this standard to establish appropriate safety and health practices and determine the applicability of regulatory limitations prior to use. For specific precautionary statements, see Section 9.*

1.7 *Fire testing is inherently hazardous. Adequate safeguards for personnel and property shall be employed in conducting these tests.*

NOTE 1—Although this test method and IEC 60695-2-13 differ in approach and in detail, data obtained using either are technically equivalent.

<sup>1</sup> This test method is under the jurisdiction of ASTM Committee D09 on Electrical and Electronic Insulating Materials and is the direct responsibility of Subcommittee D09.21 on Fire Performance Standards.

Current edition approved Nov. 1, 2014. Published November 2014. Originally approved in 1997. Last previous edition approved in 2010 as D6194 – 10. DOI: 10.1520/D6194-14.

## 2. Referenced Documents

### 2.1 ASTM Standards:<sup>2</sup>

[D1711 Terminology Relating to Electrical Insulation](#)

[E176 Terminology of Fire Standards](#)

[E220 Test Method for Calibration of Thermocouples By Comparison Techniques](#)

[E230 Specification and Temperature-Electromotive Force \(EMF\) Tables for Standardized Thermocouples](#)

[IEEE/ASTM SI-10 International System of Units \(SI\), The Modernized Metric System](#)

### 2.2 IEC Standard:

[IEC 60695-4 Fire Hazard Testing—Part 4: Terminology Concerning Fire Tests<sup>3</sup>](#)

[IEC 60695-2-12 Fire Hazard Testing—Part 2-12: Glowing/Hot-Wire Based Test Methods—Glow-Wire Flammability Test Method for Materials<sup>3</sup>](#)

[IEC 60695-2-13 Fire Hazard Testing—Section 20: Glowing/Hot-Wire Based Test Methods—Glow-Wire Coil Ignitability Test Method for Materials<sup>3</sup>](#)

### 2.3 ISO Standard:<sup>4</sup>

[ISO 13943 Fire Safety—Vocabulary](#)

## 3. Terminology

3.1 *Definitions*—Use Terminology [E176](#), ISO 13943, and IEC 60695-4 for definitions of terms used in this test method and associated with fire issues. Where differences exist in definitions, those contained in Terminology [E176](#) shall be used. Use Terminology [D1711](#) for definitions of terms used in this test method and associated with electrical insulation materials.

### 3.2 *Definitions of Terms Specific to This Standard:*

3.2.1 *glow-wire, n*—a wire of specified dimensions that can be controllably heated electrically to determine ignitability of a material.

3.2.1.1 *Discussion*—[Fig. 1](#) shows a glow-wire and its positioning.

<sup>2</sup> For referenced ASTM standards, visit the ASTM website, [www.astm.org](http://www.astm.org), or contact ASTM Customer Service at [service@astm.org](mailto:service@astm.org). For *Annual Book of ASTM Standards* volume information, refer to the standard's Document Summary page on the ASTM website.

<sup>3</sup> Available from International Electrotechnical Commission (IEC), 3 Rue de Varembe, Case postale 131, CH-1211, Geneva 20, Switzerland, <http://www.iec.ch>.

<sup>4</sup> Use undyed, soft, strong, lightweight tissue paper weighing between 12 and 30 g/m<sup>2</sup>.

\*A Summary of Changes section appears at the end of this standard

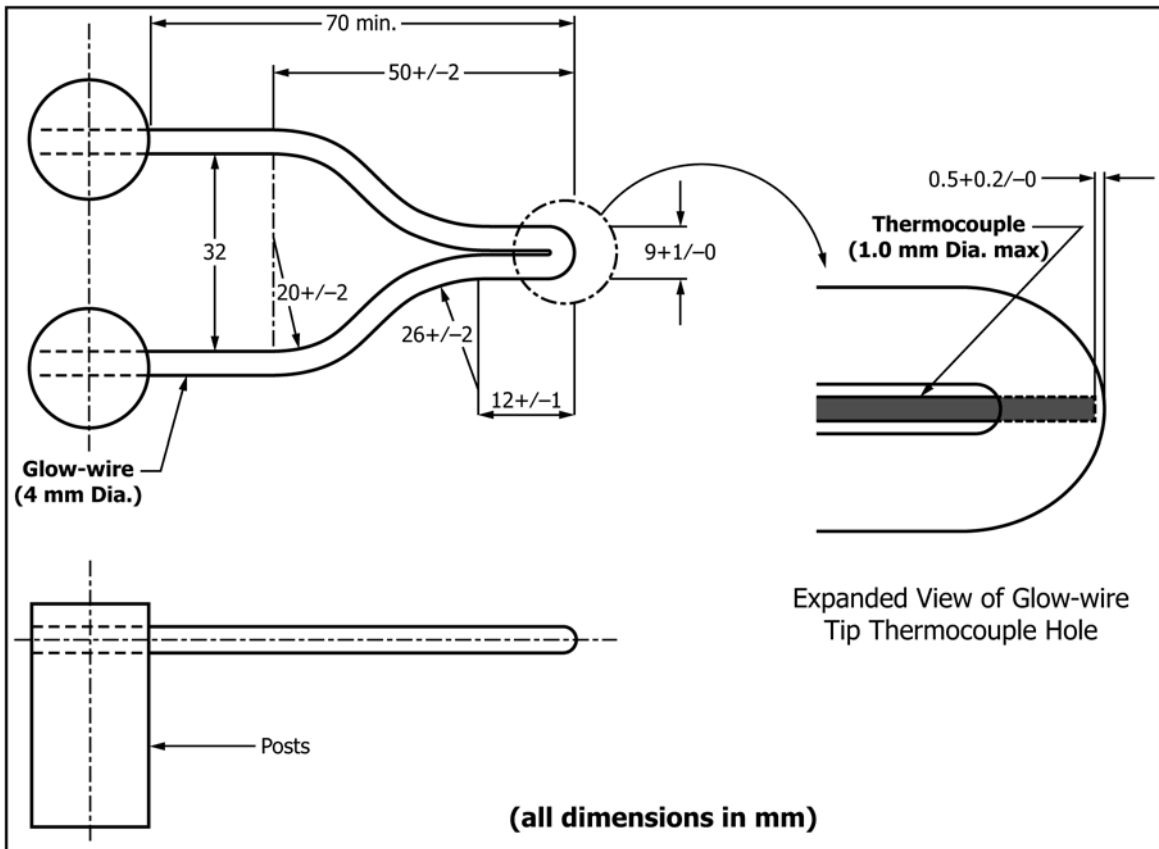

NOTE 1—All dimensions in millimetres.

FIG. 1 Glow-Wire and Positioning of Thermocouple

3.2.2 *glow-wire flammability index (GWFI), n*—the highest test temperature, during three subsequent tests for a test specimen of a given thickness, at which one of the following conditions are fulfilled: a) flames or glowing of the test specimen extinguish within 30 s after removal of the glow-wire and there is no ignition of the wrapping tissue placed underneath the test specimen; b) there is no ignition of the test specimen.

3.2.3 *glow-wire ignition temperature (GWIT), n*—the temperature which is 25°C (30°C between 900 and 960°C) higher than the GWFI.

3.2.4 *ignition, n*—initiation of combustion.

3.2.4.1 *Discussion*—Ignition is deemed to have taken place when the first of the following occurs: sustained flaming on the test specimen surface for over 5 s, or falling particles causing the appearance of flames on a tissue paper placed underneath the test specimen.

#### 4. Summary of Test Method

4.1 In this test method, a standardized test specimen (either square or round), is supported vertically and is exposed to electrical heating from a glow-wire set at pre-determined temperatures. The minimum temperature for glow-wire ignition is assessed through testing at incremental temperatures.

#### 5. Significance and Use

5.1 During operation of electrical equipment, including wires, resistors, and other conductors, it is possible for overheating to occur under certain conditions of operation, or when malfunctions occur. When this happens, a possible result is ignition of the adjacent insulation material.

5.2 This test method assesses the susceptibility of electrical insulating materials to ignition as a result of exposure to a glowing wire.

5.3 This test method determines the minimum temperature required to ignite a material by the effect of a glowing heat source, under the specified conditions of test.

5.4 This method is suitable, subject to the appropriate limitations of an expected precision of  $\pm 15\%$ , to categorize materials.

5.5 In this procedure, the specimens are subjected to one or more specific sets of laboratory conditions. If different test conditions are substituted or the end-use conditions are changed, it is not always possible by or from this test to predict changes in the fire-test-response characteristics measured. Therefore, the results are valid only for the fire test exposure conditions described in this procedure.

## 6. Apparatus

6.1 *Glow-wire*—The glow-wire shall be a Nichrome (Nickel-Chrome) wire that is iron free, with the following nominal properties: a wire composition of 20 % chromium-80 % nickel, a diameter of 4 mm, and it shall be formed to the dimensions shown in Fig. 1.

6.2 *Thermocouple*—Use Type K sheathed fine-wire thermocouple, having an overall diameter of 1.0 mm max, and wires suitable for continuous operation at temperatures up to 960°C, with the welded point located inside the sheath, for measuring the temperature of the glow-wire. Examples of suitable wire compositions are Nickel-Chromium (NiCr) and Nickel-Aluminum (NiAl).

6.2.1 Construct the thermocouple sheath of a metal that will allow the thermocouple to perform its function in air at sheath temperatures of at least 1050°C. Arrange the thermocouple in a pocket hole, drilled in the tip of the glow-wire, as shown in Fig. 1. Maintain the thermal contact between the walls of the bored hole in the glow-wire by pinning the sheathed thermocouple in place. Ensure that the thermocouple follows the movement of the tip of the glow-wire resulting from elongation caused by thermal heating.

6.3 *Temperature Indicator*—Use a temperature indicator for Type K thermocouples capable of reading up to 1000°C. Calibrate the combination thermocouple and temperature indicator in accordance with the general procedures outlined in Test Method E220. The initial calibration tolerance is defined in the tables of Specification and Temperature-Electromotive Force (EMF) Tables E230.

6.4 *Supply Circuit*—The supply circuit shall be capable of supplying up to 150 A at 2.1 V, with smooth continuous adjustment of voltage to provide the required current as needed to maintain the desired glow-wire tip temperature.

6.5 *Test Fixture*—As shown in Fig. 2, the test fixture shall be capable of holding the glow-wire in a horizontal plane and moving it against the vertical test specimen, maintaining a force of  $1.0 \pm 0.2$  N over a distance of at least 7 mm.

6.5.1 Use a weight of  $100 \pm 20$  g to provide the required force.

6.6 *Indicator Board*—Use as indicator a flat pine wood board with a smooth finish, approximately 10 mm thick, and in close contact with a single layer of tissue paper,<sup>4</sup> located at a distance of  $200 \pm 5$  mm below the glow-wire tip.

6.7 *Test Chamber*—Use as a test chamber a closed draft-free chamber that permits observation of the specimen and has a volume of at least 0.3 m<sup>3</sup>. The test chamber shall be positively vented to the outside of the test facility before and after the test, but it shall remain closed and unvented during the test. The chamber shall be equipped with an observation window.

## 7. Test Specimen

7.1 Prepare square specimens that are approximately 60 × 60 mm or round specimens that are approximately 60 mm in diameter, and of a thickness commonly encountered in practice. Thicknesses less than 0.25 mm or greater than 6.4 mm are not valid for this test method. Generally, ten specimens will suffice to complete the procedure specified in Section 9.

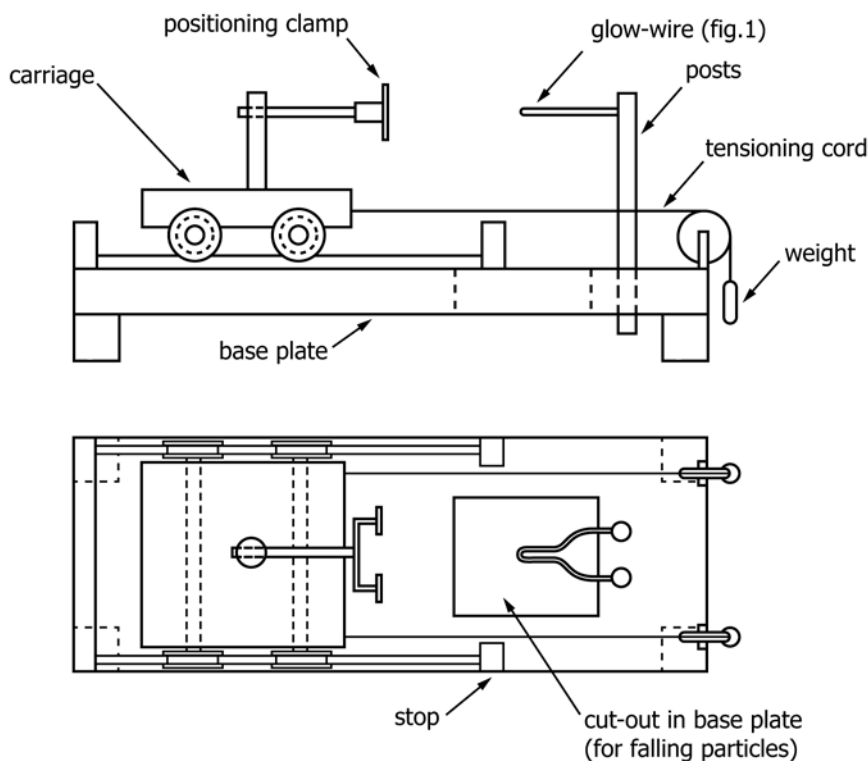

FIG. 2 Test Apparatus (Example)

## 8. Conditioning

8.1 Condition specimens, test board and tissue paper at  $23 \pm 2^\circ\text{C}$  and  $50 \pm 5\%$  relative humidity for at least 40 h prior to testing.

## 9. Safety Precautions

9.1 It is possible that fumes and products of incomplete combustion are liberated from the specimen when conducting this test. Avoid the inhalation of such fumes and products of combustion and exhaust them from the test chamber after each run.

9.2 Take precautions to safeguard the health of personnel against the risk of explosion or fire, the inhalation of smoke or other products of combustion, or the exposure to the residues potentially remaining on the specimen after testing.

## 10. Procedure

10.1 Before each test, clean the tip of the glow-wire with a wire brush to remove any residue left from previously tested materials.

10.2 Mount the specimen in the test fixture so that the surface that comes in contact with the tip of the glow-wire is vertical and any heat losses to the supporting means are insignificant. Adjust the equipment so the depth of penetration is limited to 7 mm below the surface of the specimen. Shield the specimen during the heating of the glow-wire.

10.3 Close the chamber vents and doors, making the test chamber draft free, and heat the glow-wire to the pre-determined temperature. Use the calibrated thermocouple to record the glow-wire temperature. Maintain the pre-selected glow-wire temperature for at least 60 s prior to conducting the test.

10.4 Bring the specimen in contact with the tip of the glow-wire at an applied force of  $1.0 \pm 0.2\text{ N}$  for  $30 \pm 1\text{ s}$ .

NOTE 2—The glow-wire temperature will decrease when the tip contacts the test specimen.

10.5 Observe to see whether ignition occurs during the application of the glow-wire (see 3.2.1). For the purposes of this test, ignition will be deemed to have occurred if either sustained flaming occurs (appearance of a flame on the surface of the test specimen which lasts for more than 5 s) or the tissue paper on the indicator board placed underneath the apparatus exhibits flames caused by particles falling from the test specimen.

10.5.1 If ignition occurs, repeat the test with a new test specimen, and at a temperature  $50^\circ\text{C}$  lower than that used

during the previous test. If the resulting temperature has already been used, do not retest at that temperature.

10.5.2 If ignition does not occur, repeat the test with a new test specimen, and at a temperature  $50^\circ$  higher than that used during the previous test. If the resulting temperature has already been used, do not retest at that temperature.

10.6 When a maximum temperature has been determined, following the procedure in 10.5, repeat the test with a new test specimen with a temperature interval of  $25^\circ\text{C}$  in the final approach, to determine the maximum test temperature which will not cause ignition during three consecutive tests.

10.7 The glow-wire ignition temperature is that temperature that is  $25^\circ\text{C}$  higher than the highest temperature at which the tip of the glow-wire does not cause ignition during three consecutive tests.

10.8 The glow-wire flammability index (GWFI) is the highest test temperature, during three subsequent tests for a test specimen of a given thickness, at which one of the following conditions are fulfilled:

10.8.1 Flames or glowing of the test specimen extinguish within 30 s after removal of the glow-wire and there is no ignition of the wrapping tissue placed underneath the test specimen.

10.8.2 There is no ignition of the test specimen.

## 11. Report

11.1 Report the following information:

11.1.1 Complete identification of the material tested including type, source, and manufacturer's code number,

11.1.2 Thickness of specimens tested,

11.1.3 The glow-wire ignition temperature, and

11.1.4 The glow-wire flammability index.

## 12. Precision and Bias

12.1 *Precision*—It is not possible to specify the precision of the procedure in this test method for measuring the glow-wire ignition temperature because insufficient data has been developed and compiled for a reliable statistical analysis.

12.2 *Bias*—No information can be presented on the bias of the procedure in this test method for measuring the glow-wire ignition temperature because no material having an acceptable reference value is available.

## 13. Keywords

13.1 electrically heated sources; flame; glow-wire; ignitability; ignition; plastic electrical insulating materials

**SUMMARY OF CHANGES**

Committee **D09** has identified the location of selected changes to this standard since the last issue (D6194 – 10) that may impact the use of this standard. (Approved Nov. 1, 2014.)

(1) Removed Note 2.

(2) Added subsection **6.5.1**.

*ASTM International takes no position respecting the validity of any patent rights asserted in connection with any item mentioned in this standard. Users of this standard are expressly advised that determination of the validity of any such patent rights, and the risk of infringement of such rights, are entirely their own responsibility.*

*This standard is subject to revision at any time by the responsible technical committee and must be reviewed every five years and if not revised, either reapproved or withdrawn. Your comments are invited either for revision of this standard or for additional standards and should be addressed to ASTM International Headquarters. Your comments will receive careful consideration at a meeting of the responsible technical committee, which you may attend. If you feel that your comments have not received a fair hearing you should make your views known to the ASTM Committee on Standards, at the address shown below.*

*This standard is copyrighted by ASTM International, 100 Barr Harbor Drive, PO Box C700, West Conshohocken, PA 19428-2959, United States. Individual reprints (single or multiple copies) of this standard may be obtained by contacting ASTM at the above address or at 610-832-9585 (phone), 610-832-9555 (fax), or [service@astm.org](mailto:service@astm.org) (e-mail); or through the ASTM website ([www.astm.org](http://www.astm.org)). Permission rights to photocopy the standard may also be secured from the Copyright Clearance Center, 222 Rosewood Drive, Danvers, MA 01923, Tel: (978) 646-2600; <http://www.copyright.com/>*