



Standard Practice for Stitches and Seams¹

This standard is issued under the fixed designation D6193; the number immediately following the designation indicates the year of original adoption or, in the case of revision, the year of last revision. A number in parentheses indicates the year of last reapproval. A superscript epsilon (ϵ) indicates an editorial change since the last revision or reapproval.

This standard has been approved for use by agencies of the U.S. Department of Defense.

1. Scope

1.1 This practice covers the requirements and characteristics of stitches and seams used in the fabrication of sewn items.

1.2 This practice identifies the category, formation, and general purpose for stitch types and seam types used in the fabrication of sewn items.

1.3 Subsequent to a general discussion of stitches and seams that include schematic indices, this practice is comprised of the following sections that are listed in the order in which they appear:

1.3.1 *Section 5*—Classification of Stitch Types for which drawings are shown in *Stitch Figs. 1-69*,

1.3.2 *Section 6*—Classification of Seam Types for which drawings are shown in *Seam Figs. 70-288*, and

1.3.3 *Annex A1*—Seam Assembly Recommendations.

1.4 *This standard does not purport to address all of the safety concerns, if any, associated with its use. It is the responsibility of the user of this standard to establish appropriate safety and health practices and determine the applicability of regulatory limitations prior to use.*

2. Referenced Documents

2.1 *ASTM Standards*:²

[D123 Terminology Relating to Textiles](#)

3. Terminology

3.1 *Definitions*:

3.1.1 *bartack*, *n*—a reinforcement stitch that effectively minimizes tearing at the ends of critical stress stitchlines.

3.1.1.1 *Discussion*—Examples of critical stress stitchlines include: ends of seams, zippers, pocket flaps, crotch/seat seams, collars, webbing and other components. If the bartacking process exhibits an insufficient number of stitches, im-

¹ This practice is under the jurisdiction of ASTM Committee D13 on Textiles and is the direct responsibility of Subcommittee D13.54 on Subassemblies.

Current edition approved Jan. 1, 2016. Published February 2016. Originally approved in 1997. Last previous edition approved in 2011 as D6193 – 11. DOI: 10.1520/D6193-16.

² For referenced ASTM standards, visit the ASTM website, www.astm.org, or contact ASTM Customer Service at service@astm.org. For *Annual Book of ASTM Standards* volume information, refer to the standard's Document Summary page on the ASTM website.

proper thread size relationship or shortened bartack stitched length then it will fail under stress. Bartacking, because of the stitch density, can exhibit severe needle-cutting, thus creating a self-destructive characteristic if number of stitches is excessive, or sewing needle or thread size is too large for fabric. Bartacking is specified strictly as a relationship between length, width or throw and total stitches. It does not incorporate stitches per inch as a typical seam may specify.

3.1.1.2 *Discussion*—Counting finished bartack stitches is virtually impossible since the overall process consists of three components. The process begins in a horizontal position to achieve the required length and then forms the familiar zig-zag stitch-line along the horizontal plane including backstitching at both ends to lock in the zig-zag stitches to prevent raveling. The zig-zag stitches criss-cross the initial horizontal stitch line thus virtually hiding the initial stitch line.

3.1.2 *needle damage*, *n*—in sewn fabrics, the partial or complete yarn severance or fiber fusing caused by a needle passing through a fabric during sewing.

3.1.2.1 *Discussion*—This can also be referred to as needle cuts.

3.1.3 *seam*, *n*—a line where two or more fabrics are joined, usually near the edge. *See also* *sewn seam*, *glued seam*, *stapled seam*, *thermally bonded seam*.)

3.1.4 *seam allowance*, *n*—in sewn fabrics, the distance from the edge of a fabric to the parallel stitch line furthest from that edge.

3.1.5 *seam assembly*, *n*—the composite structure obtained when fabric(s) are joined by means of a seam.

3.1.6 *seam damage*, *n*—in sewn fabrics, an adverse change in the physical condition of one or more of the components in a seam which would reduce the seam acceptability such as yarn slippage, needle damage, or fabric rupture.

3.1.7 *seam efficiency*, *n*—in sewn fabrics, the ratio of seam strength to fabric strength.

3.1.7.1 *Discussion*—For some constructions, yarn strength and stitch type can contribute to a higher seam efficiency value.

3.1.8 *seam slippage*, *n*—in sewn fabrics, the displacement of the fabric yarn parallel and adjacent to the stitch line.

TABLE 1 Stitch and Seam Defects

<i>Stitch Defects</i>	<i>Seam Assembly Defects</i>
Loose stitches	Puckers
Poorly formed stitches	Twists
Crowded stitches	Plaits
Tight stitches	Undulations
Crooked stitches	Run-off (raised seams)
Skipped stitches	Raw edges exposed (felled seams)

3.1.9 *seam type, n*—in sewn fabrics, an alphanumeric designation relating to the essential characteristics of fabric positioning and rows of stitching in a specified sewn fabric seam.

3.1.10 *sew, v*—to unite or fasten with stitches.

3.1.11 *sewing thread, n*—a flexible, small-diameter yarn or strand, usually treated with a surface coating, lubricant, or both, intended to be used to stitch one or more pieces of material or an object to a material.

3.1.12 *sewn seam, n*—in sewn fabrics, a juncture at which two or more planar structures such as textile fabrics, are joined by sewing, usually near the edge.

3.1.13 *stitch, n*—in sewing, the configuration of the interlacing of sewing thread in a specific repeated unit. (See also *stitching, and stitch type*.)

3.1.14 *stitch density, n*—in sewn seams, the number of stitches per unit length in one row of stitching in the seam.

3.1.14.1 *Discussion*—This is usually expressed as stitches per inch (spi).

3.1.15 *stitch gage, n*— in sewn seams, the perpendicular distance between adjacent parallel rows of stitching.

3.1.16 *stitch type, n*— in sewn seams, a numerical designation relating to the essential characteristics of the interlacing of sewing thread(s) in a specified stitch.

3.1.17 *stitching, n*—a series of stitches embodied in a material or materials of planar structure such as woven textile fabrics usually for ornamental purposes or finishing an edge, or both.

3.1.18 *yarn slippage, n*—in sewn seams in sewn fabrics, the displacement of one or more yarns from the original position, causing differences in alignment, spacing, or both.

3.2 For definitions of other textile terms used in this practice, refer to Terminology [D123](#).

4. Significance and Use

4.1 Seam engineering, the determination of the best stitch type, seam configuration, and thread type which should be used for a particular assembly, requires a thorough knowledge of many variables. The improper selection of any one component can result in failure of the sewn junction, and ultimately failure of the product manufactured.

4.2 *General Characteristics*—The characteristics of a properly constructed sewn seam are strength, elasticity, durability, security, and appearance. These characteristics must be balanced with the properties of the material to be joined to form the optimum sewn seam. The end use of the item will govern

the relative importance of these characteristics. The selection of the seam type and stitch type should be based upon these considerations.

4.2.1 *Strength*—The seam efficiency of the sewn seam should be as high as possible. This will produce sewn seam strength with a balanced construction that will withstand the forces encountered in the use of the sewn item. The elements affecting the strength of a sewn seam are:

4.2.1.1 Fabric type and strength,

4.2.1.2 Seam type,

4.2.1.3 Stitch type,

4.2.1.4 Stitch density (spi),

4.2.1.5 Thread tension, and

4.2.1.6 Thread strength.

4.2.2 *Elasticity*—The elasticity of a sewn seam should be slightly greater than that of the material which it joins. This will enable the material to support its share of the forces encountered for the intended end use of the sewn item. The elasticity of a sewn seam depends upon:

4.2.2.1 Fabric type and strength,

4.2.2.2 Seam type,

4.2.2.3 Stitch type,

4.2.2.4 Stitch density (spi),

4.2.2.5 Thread tension, and

4.2.2.6 Thread elasticity.

4.2.3 *Durability*—The durability of a sewn seam depends largely upon its strength relative to the elasticity of the seam and the elasticity of the material. However, in less elastic, tightly woven or dense materials, there is a tendency for the plies to “work” or slide on each other. To form a durable sewn seam in these types of fabrics, the thread size must be carefully chosen. The stitch density also needs to be carefully determined for the material so as not to cause excess tension which will unbalance the elasticity and cause puckering. It is also important to minimize abrasion and wear by contact with outside agencies to promote durability.

4.2.4 *Security*—The security of a sewn seam depends chiefly upon the stitch type, spi, and its susceptibility to become unraveled. The stitch must be well set to the material to prevent snagging that can cause rupture of the thread and unraveling of certain stitch types.

4.2.5 *Appearance*—The appearance of a sewn seam generally is governed by the proper relationship between the size and type of thread, the stitch density, and the texture and weight of the fabric.

4.2.5.1 In addition to these general characteristics, the technique and skill of the sewing machine operators also govern the appearance of the sewn seams. Some of the factors which will adversely affect the appearance are shown in [Table 1](#).

5. Classification of Stitch Types

5.1 *Function*—Because all stitch types require that a needle penetrate a fabric while transporting a sewing thread, it is important to understand how the unique characteristics of every stitch type are dependent upon the mechanical actions of the sewing machine. See [Stitch Type Figs. 1-66](#).

5.2 *Stitch Requirements*:

DIRECTION OF SUCCESSIVE STITCH FORMATION

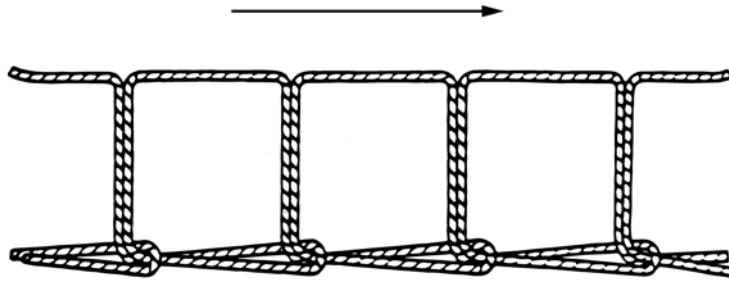

NOTE 1—This type of stitch shall be formed with one needle thread that shall be passed through the material and interlooped with itself on the undersurface of the material.

FIG. 1 Stitch Type 101

DIRECTION OF SUCCESSIVE STITCH FORMATION

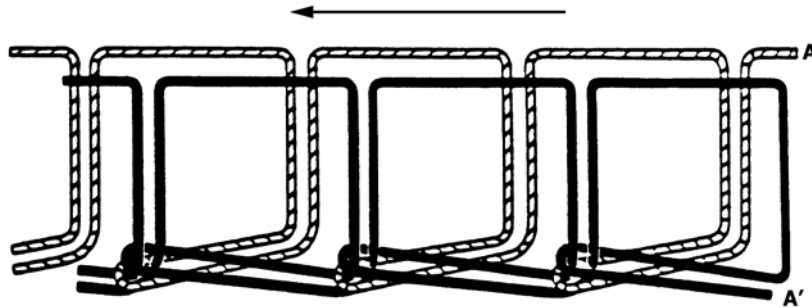

NOTE 1—This type of stitch shall be formed with two needle threads A and A'. Both threads shall be passed through the material and thread A' shall be interlooped with itself and with thread A.

FIG. 2 Stitch Type 102

DIRECTION OF SUCCESSIVE STITCH FORMATION

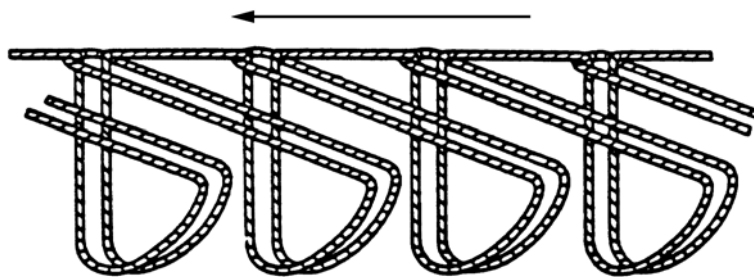

NOTE 1—This type of stitch shall be formed with one needle thread, which shall interloop with itself on the top surface of the material. The thread shall be passed through the top ply and horizontally through portions of the bottom ply without penetrating it the full depth.

FIG. 3 Stitch Type 103

DIRECTION OF SUCCESSIVE STITCH FORMATION

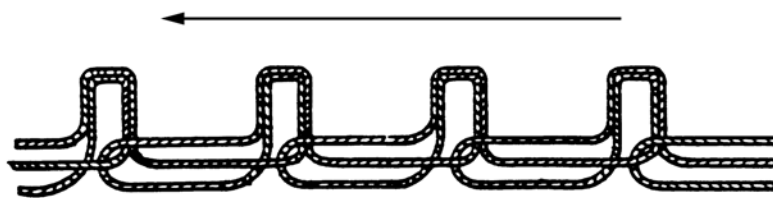

NOTE 1—This type of stitch shall be formed with one needle thread which shall interloop with itself on the undersurface of the material.

FIG. 4 Stitch Type 104

5.2.1 Stitches are divided into six classes which are identified by the first digit of three digit numerals. Each class is

divided into several types which are identified by the second

DIRECTION OF SUCCESSIVE STITCH FORMATION

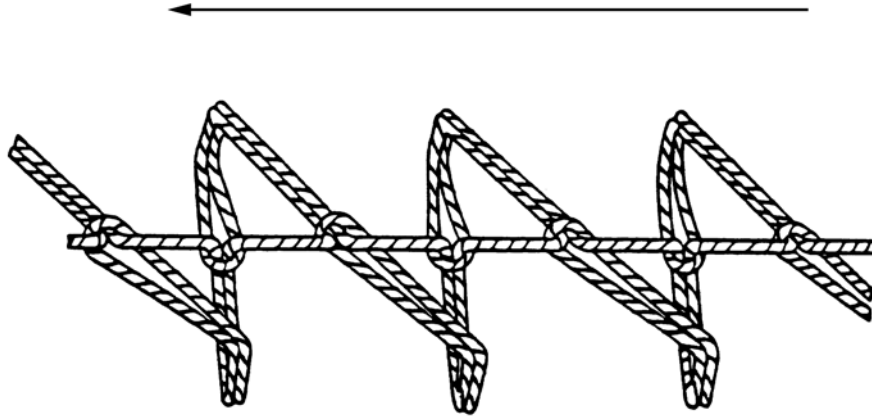

NOTE 1—This type of stitch shall be formed with one needle thread which shall be passed through the top ply of material and through portions of the bottom ply without penetrating it the full depth, on either side of a center line. The thread shall interloop with itself on the surface of the material at the center line.

FIG. 5 Stitch Type 105

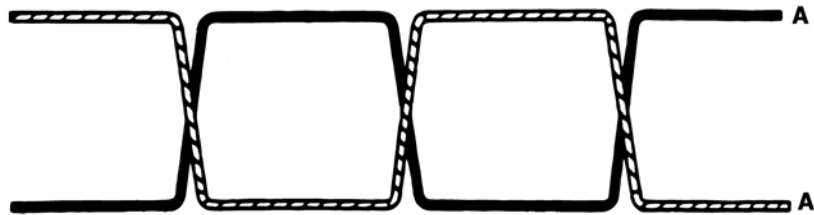

NOTE 1—This type of stitch shall be formed with two needle threads, A and A', which shall be passed through the material in the same perforations from opposite directions without interlacing or interlooping.

FIG. 6 Stitch Type 201

DIRECTION OF SUCCESSIVE STITCH FORMATION

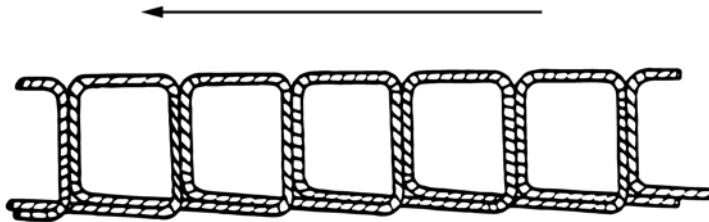

NOTE 1—This type of stitch shall be formed with one needle thread, which shall be passed through the material brought forward two stitch lengths, passed back through the material and brought back one stitch length before being passed through the material a third time.

FIG. 7 Stitch Type 202

and third digit. All stitch types shall conform to the drawings unless otherwise specified.

5.2.1.1 *Stitch Class 100*—This class of stitch (Types 101 through 105) is formed with one or more needle threads and requires interlooping. A loop (or loops) of thread(s) shall be passed through the material and be secured by interlooping with succeeding loop or loops, after they are passed through the material, to form a stitch.

5.2.1.2 *Stitch Class 200*—This class of stitch (Types 201 through 205) is formed by hand with one or more needle threads and requires that each thread passes through the material as a single line of thread. Each stitch is secured by the single line of thread passing in and out of the material or the

interlooping of the threads with themselves. When more than one thread is used, the threads pass through the same perforations in the material.

5.2.1.3 *Stitch Class 300*—This class of stitch (Types 301 through 316) is formed with two or more groups of threads and requires the interlacing of the two groups. Loops of the first group are passed through the material where they are secured by the thread(s) of the second group to form a stitch.

5.2.1.4 *Stitch Class 400*—This class of stitch (Types 401 through 407) shall be formed with two or more groups of threads and requires the interlacing and interlooping of the loops of the two groups. Loops of the first group of threads are

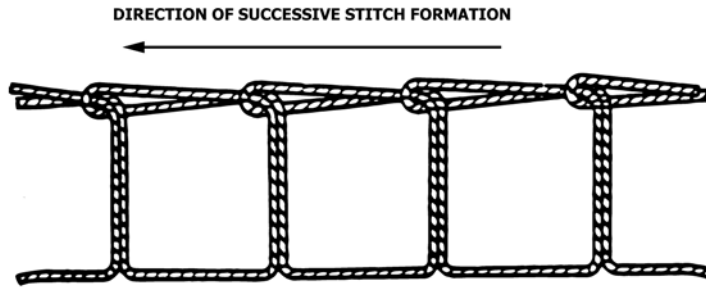

NOTE 1—This type of stitch shall be formed with one needle thread, which shall be passed through the material from the underside and immediately passed back through the same perforation to form a loop on the surface of the material. The needle shall be advanced one stitch length, passed through the material and the loop and immediately passed back through the loop and the same needle perforation, and a new loop shall be formed to receive the succeeding stitch.

FIG. 8 Stitch Type 203

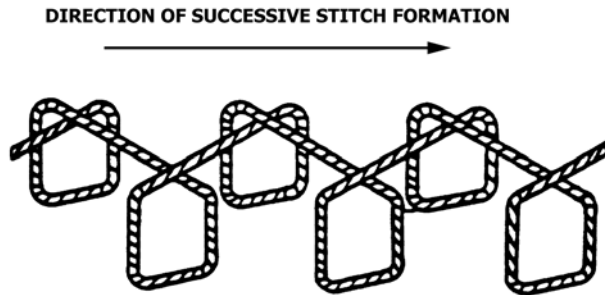

NOTE 1—This type of stitch shall be formed with one needle thread, which shall be passed through the material and brought back one stitch length and then passed back up through the material. The needle shall be moved diagonally across the material and forward one stitch length, passed through the material, brought back one stitch length and again passed to the surface of the material. This process shall be repeated to form a crisscross pattern of stitches on the surface and parallel rows of separated and off-set stitches on the underside of the material.

FIG. 9 Stitch Type 204

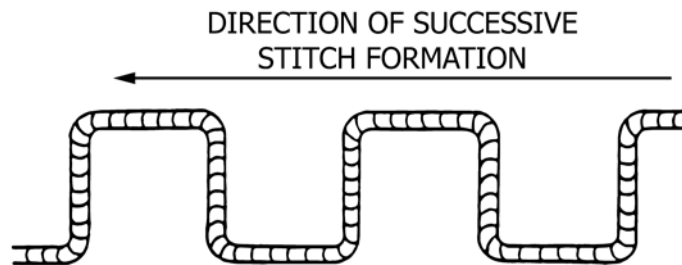

NOTE 1—This type of stitch shall be formed with one or more needle threads and has for a general characteristic that the thread does not interloop with itself or any other thread or threads. The thread is passed completely through the material by means of a double pointed center eye needle and returned by another path. This class of stitch simulates hand stitching.

FIG. 10 Stitch Type 205

passed through the material and are secured by interlacing and interlooping with loops of the second group to form a stitch.

5.2.1.5 *Stitch Class 500*—This class of stitch (Types 501 through 522) is formed with one or more groups of thread, and requires that loops from at least one group of thread shall pass around the edge of the material. Loops of one group of thread are passed through the material and are secured by interlooping with themselves before succeeding loops are passed through the material, or secured by interlooping with loops of one or more interlooped groups of threads before succeeding loops of the first group are again passed through the material.

5.2.1.6 *Stitch Class 600*—This class of stitch (Types 601 through 607) is formed with two or more groups of threads, and requires that two of the groups cover the raw edges of both

surfaces of the material. Loops of the first group of thread are passed through loops of the third group already cast on the surface of the material and then through the material where they are interlooped with loops of the second group of thread on the underside of the material. The one exception to this procedure is stitch type 601 where only two groups of thread are used and the function of the third group is performed by one of the threads in the first group.

6. Classification of Seam Types

6.1 Function:

6.1.1 Seam classification relates directly to the positioning of fabric sections at the junction where these sections are sewn.

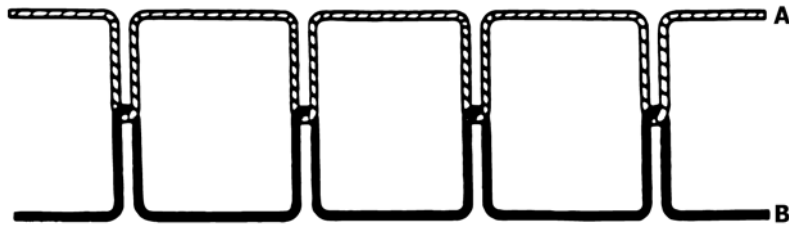

NOTE 1—This type of stitch shall be formed with two threads: one needle thread, A, and one bobbin thread, B. A loop of thread A shall be passed through the material and interlaced with thread B. Thread A shall be pulled back so that the interlacing shall be midway between surfaces of the material or materials being sewn.

FIG. 11 Stitch Type 301

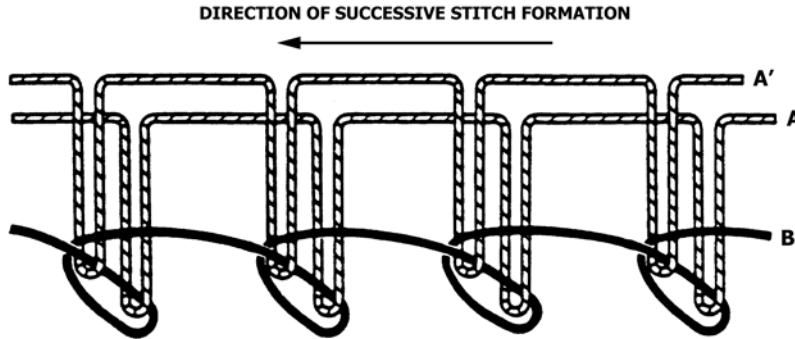

NOTE 1—This type of stitch shall be formed with three threads: two needle threads, A and A', and one bobbin thread, B. Loops of threads A and A' shall be passed through the material and interlaced with thread B. The interlacings shall be on the underside of the material.

FIG. 12 Stitch Type 302

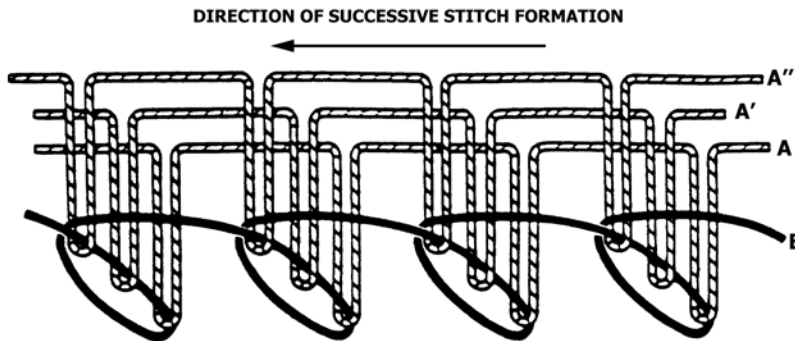

NOTE 1—This type of stitch shall be formed with four threads: three needle threads, A and A' and A'', and one bobbin thread, B. Loops of threads A, A' and A'' shall be passed through the material and interlaced with thread B. The interlacings shall be on the underside of the material.

FIG. 13 Stitch Type 303

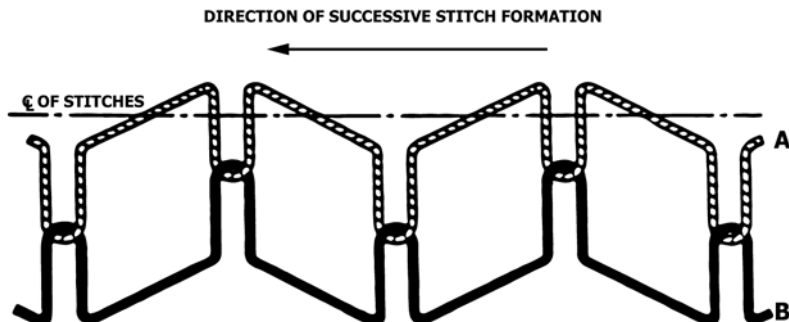

NOTE 1—This type of stitch shall be formed with two threads: one needle thread, A, and one bobbin thread, B. This stitch type is exactly the same as stitch type 301 except that successive single stitches form a symmetrical zigzag pattern.

FIG. 14 Stitch Type 304

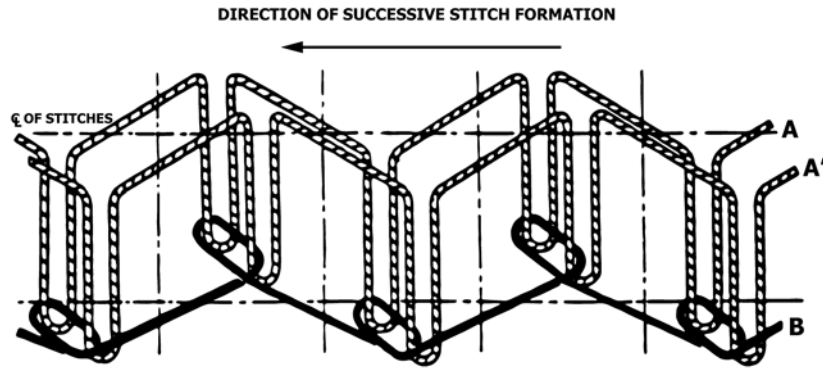

NOTE 1—This type of stitch shall be formed with three threads: two needle threads, A and A', and one bobbin thread, B. Loops of threads A and A' shall be passed through the material and interlaced with thread B and the interlacing shall be left on the underside of the material. Successive single stitches form a symmetrical zigzag pattern.

FIG. 15 Stitch Type 305

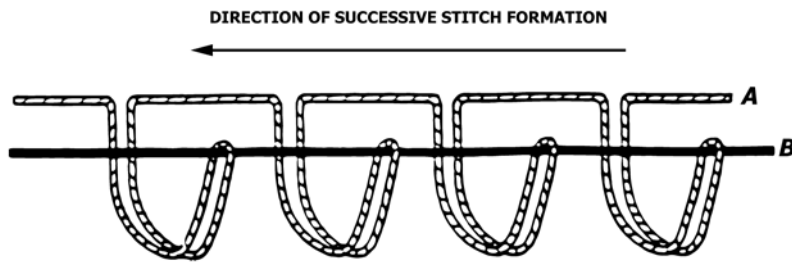

NOTE 1—This type of stitch shall be formed with two threads: one needle thread, A, and one bobbin thread, B. Loops of thread A shall be passed through the top ply of material and horizontally through portions of the bottom ply without penetrating it the full depth and shall be interlaced with thread B on the top surface of the bottom ply of material.

FIG. 16 Stitch Type 306

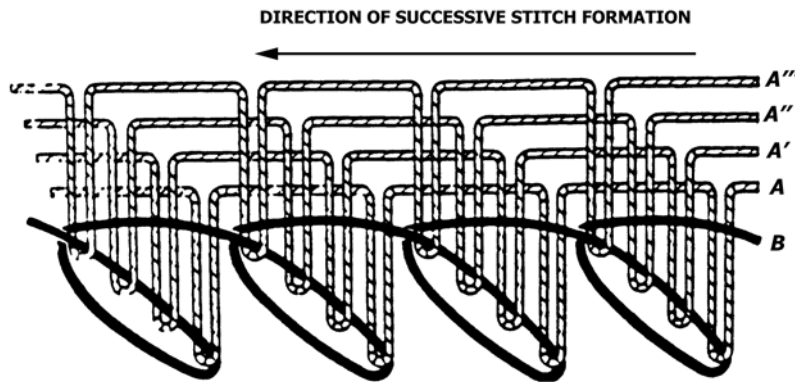

NOTE 1—This type of stitch shall be formed with five threads: four needle threads, A, A', A'', A''', and one bobbin thread, B. Loops of threads A, A', A'', A''', shall be passed through the material and interlaced with thread B. The interlacings shall be on the underside of the material.

FIG. 17 Stitch Type 307

6.1.2 All seam types are classified by an alphabetical designation. See Figs 282–291.

6.1.3 Seams are divided into six classes. Each class is subdivided into types and are designated by symbols as follows:

6.1.3.1 *Class of Seam*—Two or more upper case letters.

6.1.3.2 *Types of the Class*—One or more lower case letters.

6.1.3.3 *Number of Rows of Stitches*—One or more Arabic numerals. *Example*—The symbol for a simple super-imposed seam type with one row of stitches is: SSa-1.

6.1.3.4 Generally, most seam types can be produced using multiple rows of stitching. The symbol for the seam type will change with the number of rows of stitches: SSa-2, SSa-3, SSa-4, etc.

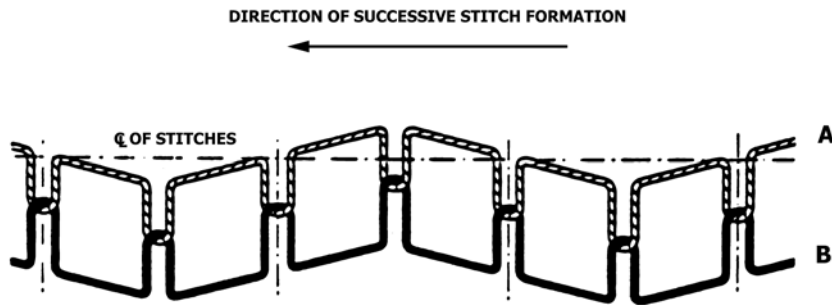

NOTE 1—This type of stitch shall be formed with two threads: one needle thread, A, and one bobbin thread, B. This stitch type is the same as stitch type 304 except that successive pairs of stitches form a symmetrical zigzag pattern.

FIG. 18 Stitch Type 308

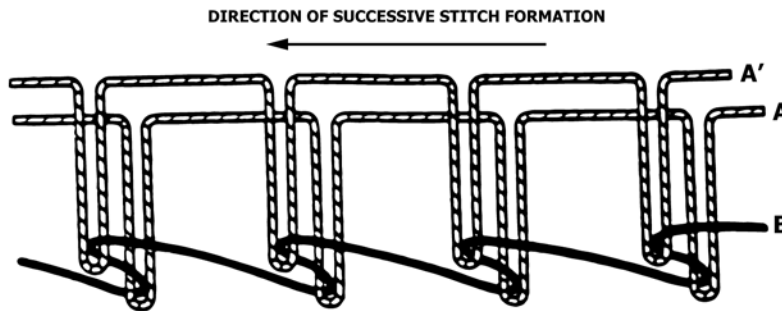

NOTE 1—This type of stitch shall be formed with three threads: two needle threads, A and A', and one bobbin thread, B. Loops of threads A and A' shall be passed through the material and interlaced with thread B. The interlacings shall be left on the underside of the material.

FIG. 19 Stitch Type 309

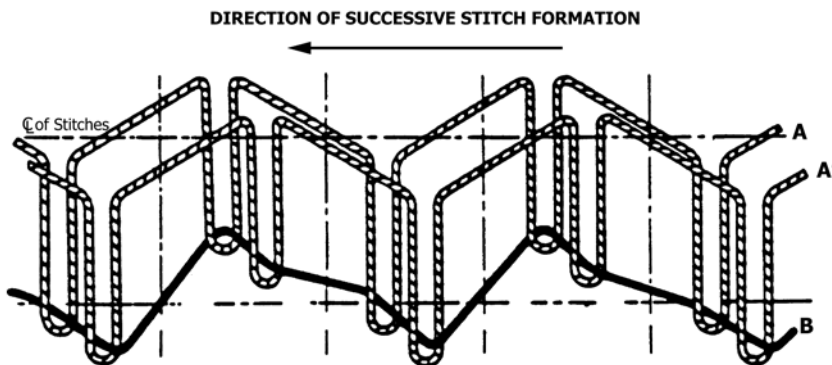

NOTE 1—This type of stitch shall be formed with three threads: two needle threads, A and A', and one bobbin thread, B. Loops of threads A and A' shall be passed through the material and interlaced with thread B, and the interlacings shall be left on the underside of the material. Successive single stitches form a symmetrical zigzag pattern.

FIG. 20 Stitch Type 310

6.2 Seam Requirements:

6.2.1 All seam types shall conform to the applicable drawings unless otherwise specified. See Seam Figs. 70-288.

6.2.1.1 Seam Class SS—This class of seam requires that the plies of material are superimposed and seamed with one or more rows of stitches (Figs. 289-298).

6.2.1.2 Seam Class LS—This class of seam requires that the plies of material are lapped and seamed with one or more rows of stitches.

6.2.1.3 Seam Class BS—This class of seam is formed by folding a binding strip over the edge of one or more plies of material and seaming the binding strip to the material with one or more rows of stitches.

6.2.1.4 Seam Class FS—This class of seam is formed by sewing the abutted edges of material together in such a manner that the stitches extend across and cover or tend to cover the edges of the plies joined.

6.2.1.5 Seam Class OS—This class of seam requires that a series of stitches are embodied in a material either in a straight line, a curve, or following a design, for ornamental purposes.

6.2.1.6 Seam Class EF—This class of seam requires that edge finishing is accomplished by either: sewing a series of stitches at or over the edge of a material while the edge may or may not be folded as specified, or the edge of the material is folded and stitched to the body of the material with a series of stitches.

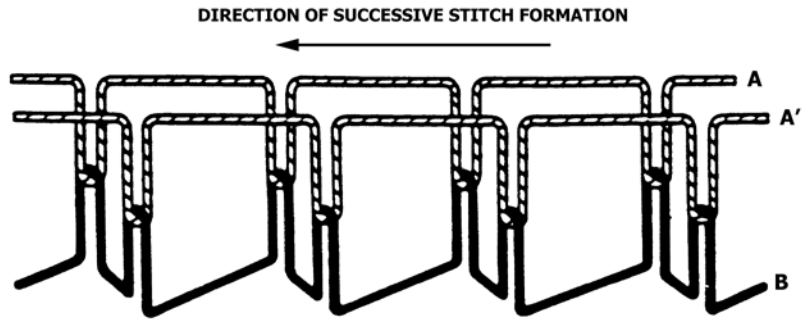

NOTE 1—This type of stitch shall be formed with three threads: two needle threads, A and A', and one bobbin thread, B. Loops of threads A and A' shall be passed through the material and interlaced with thread B. Threads A and A' shall be pulled back so that the interlacings shall be midway between surfaces of the material or materials being sewn.

FIG. 21 Stitch Type 311

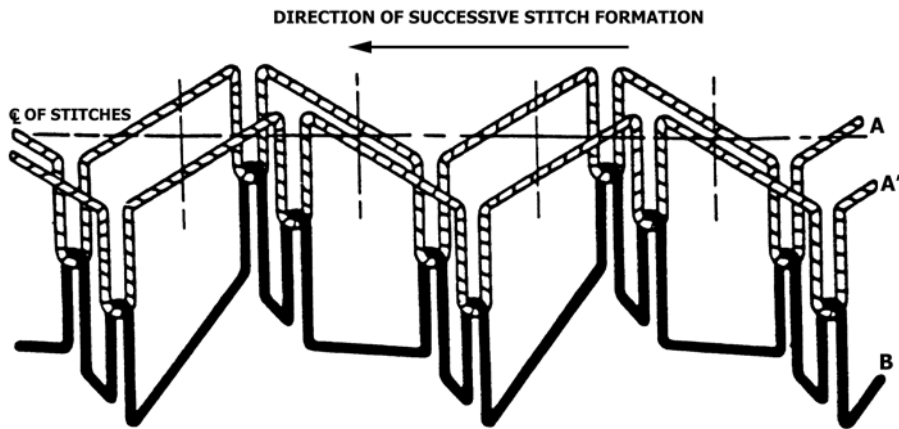

NOTE 1—This type of stitch shall be formed with three threads: two needle threads, A and A', and one bobbin thread, B. This stitch type is exactly the same as stitch type 311 except that successive single stitches form a symmetrical zigzag pattern.

FIG. 22 Stitch Type 312

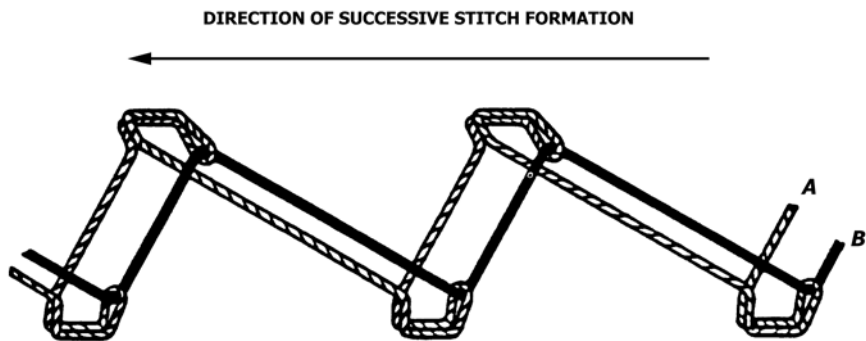

NOTE 1—This type of stitch shall be formed with two threads: one needle thread, A, and one bobbin thread, B. Loops of thread A shall be passed horizontally through portions of both plies of material without penetrating the full depth, and shall be interlaced with thread B on the top of the material.

FIG. 23 Stitch Type 313

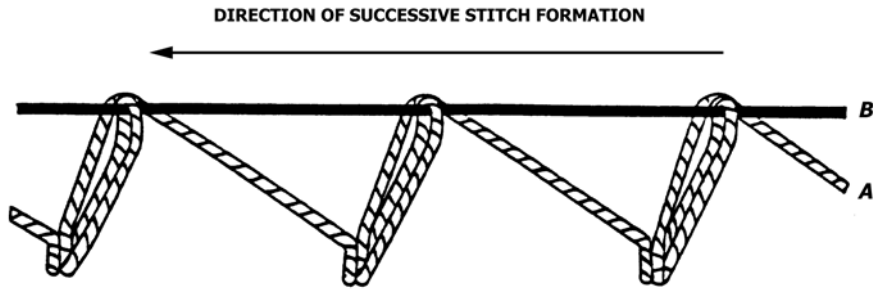

NOTE 1—This type of stitch shall be formed with two threads: one needle thread, A, and one bobbin thread, B. Loops of thread A shall be passed through the top ply of material and horizontally through portions of the bottom ply without penetrating the full depth and shall be interlaced with thread B on the top of the material.

FIG. 24 Stitch Type 314

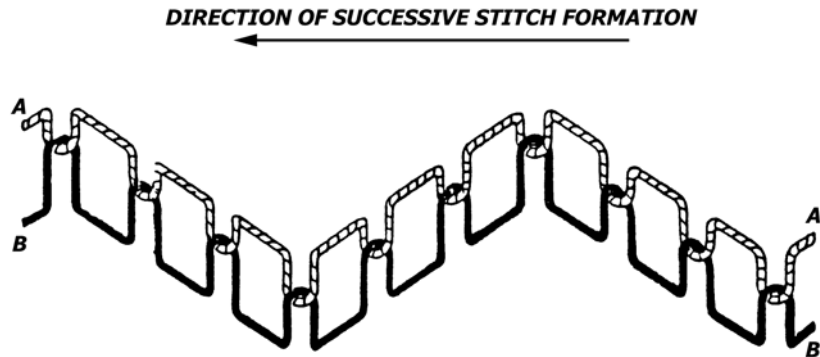

NOTE 1—This type of stitch shall be formed with two threads: one needle thread, A, and one bobbin thread, B. This stitch type is the same as stitch type 304 except that successive groups of three stitches form a symmetrical zig-zag pattern.

FIG. 25 Stitch Type 315

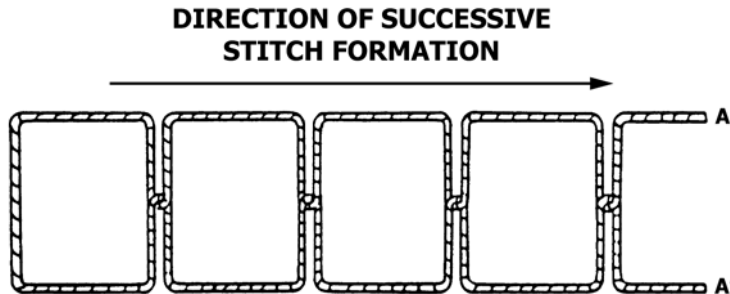

NOTE 1—This type of stitch shall be formed with one continuous needle thread, which after the first needle penetration is divided into two parts: part one, needle thread A, and one reel thread, A'. In subsequent penetrations thread A is passed through the material and interlaced with thread A. Thread A shall be pulled up so that the interlacing is midway between the surfaces of the material or materials being sewn. This stitch type is identical to stitch type 301 except for the initial stitch.

FIG. 26 Stitch Type 316

DIRECTION OF SUCCESSIVE STITCH FORMATION

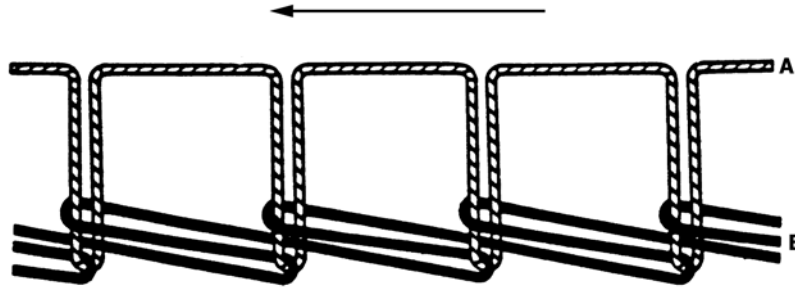

NOTE 1—This type of stitch shall be formed with two threads: one needle thread, A, and one looper thread, B. Loops of thread A shall be passed through the material and interlaced and interlooped with loops of thread B. The interloopings shall be drawn against the underside of the bottom ply of material.

FIG. 27 Stitch Type 401

DIRECTION OF SUCCESSIVE STITCH FORMATION

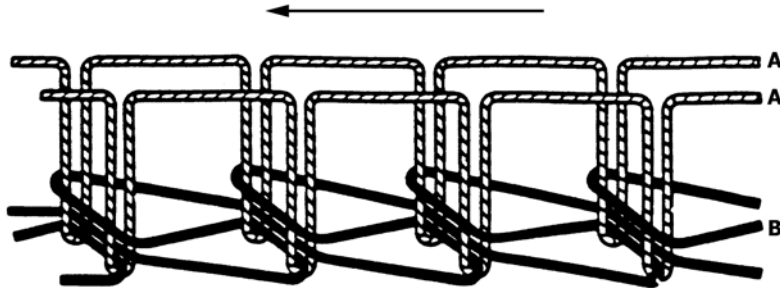

NOTE 1—This type of stitch shall be formed with three threads: two needle threads A and A' and one looper thread, B. Loops of threads A and A' shall be passed through the material and interlaced and interlooped with loops of thread B. The interloopings shall be drawn against the underside of the material.

FIG. 28 Stitch Type 402

DIRECTION OF SUCCESSIVE STITCH FORMATION

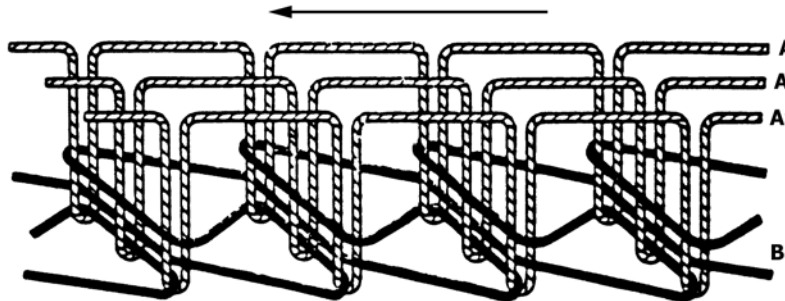

NOTE 1—This type of stitch shall be formed with four threads: three needle threads, A, A' and A'' and one looper thread, B. Loops of threads A, A' and A'' shall be passed through the material and interlaced and interlooped with loops of thread B. The interloopings shall be drawn against the underside of the material.

FIG. 29 Stitch Type 403

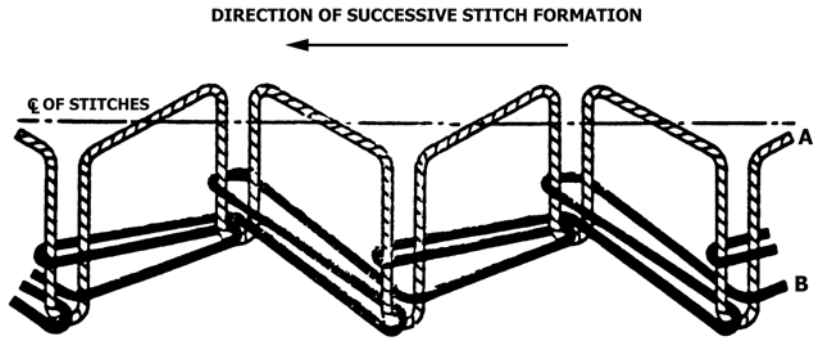

NOTE 1—This type of stitch shall be formed with two threads: one needle thread, A, and one looper thread, B. This stitch is the same as stitch type 401 except that successive single stitches form a symmetrical zigzag pattern.

FIG. 30 Stitch Type 404

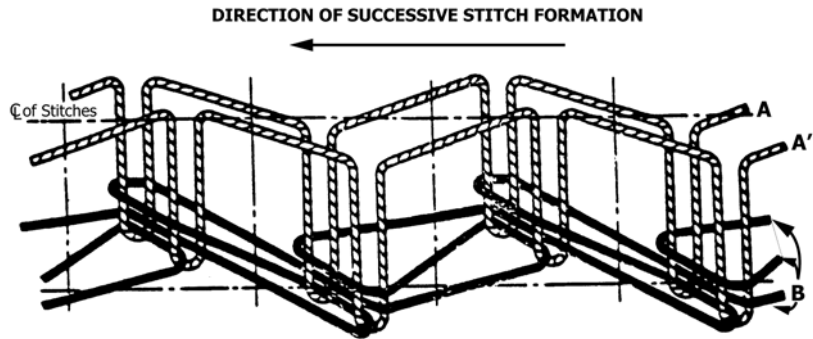

NOTE 1—This type of stitch shall be formed with three threads: two needle threads, A and A', and one looper thread, B. This stitch is the same as stitch type 402 except that successive stitches form a symmetrical zigzag pattern.

FIG. 31 Stitch Type 405

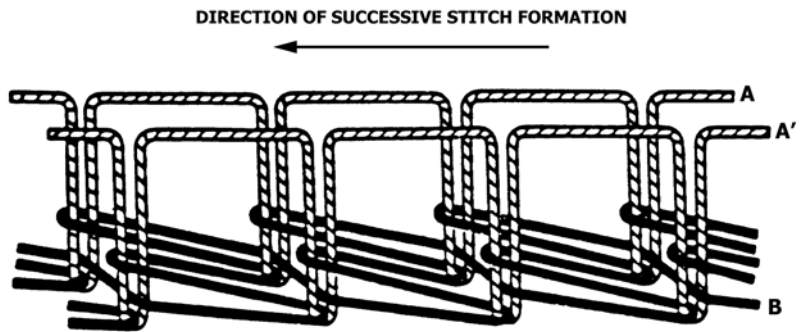

NOTE 1—This type of stitch shall be formed with three threads: two needle threads, A and A' and one looper thread, B. Loops of threads A and A' shall be passed through the material and interlaced and interlooped with loops of thread B. The interloopings shall be drawn against the underside of the material.

FIG. 32 Stitch Type 406

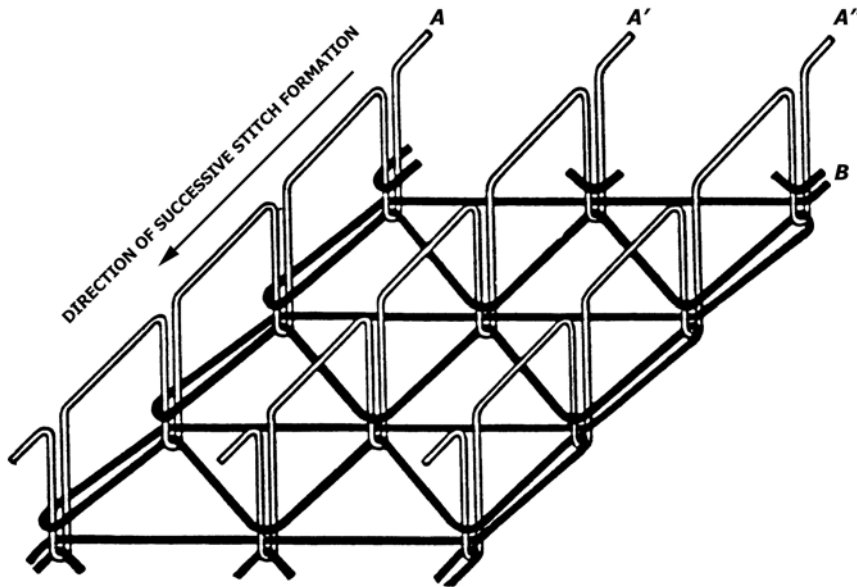

NOTE 1—This type of stitch shall be formed with four threads: three needle threads A, A', and A'' and one looper thread, B. Loops of threads A, A', and A'' shall be passed through the material and shall be drawn against the underside of the material.

FIG. 33 Stitch Type 407

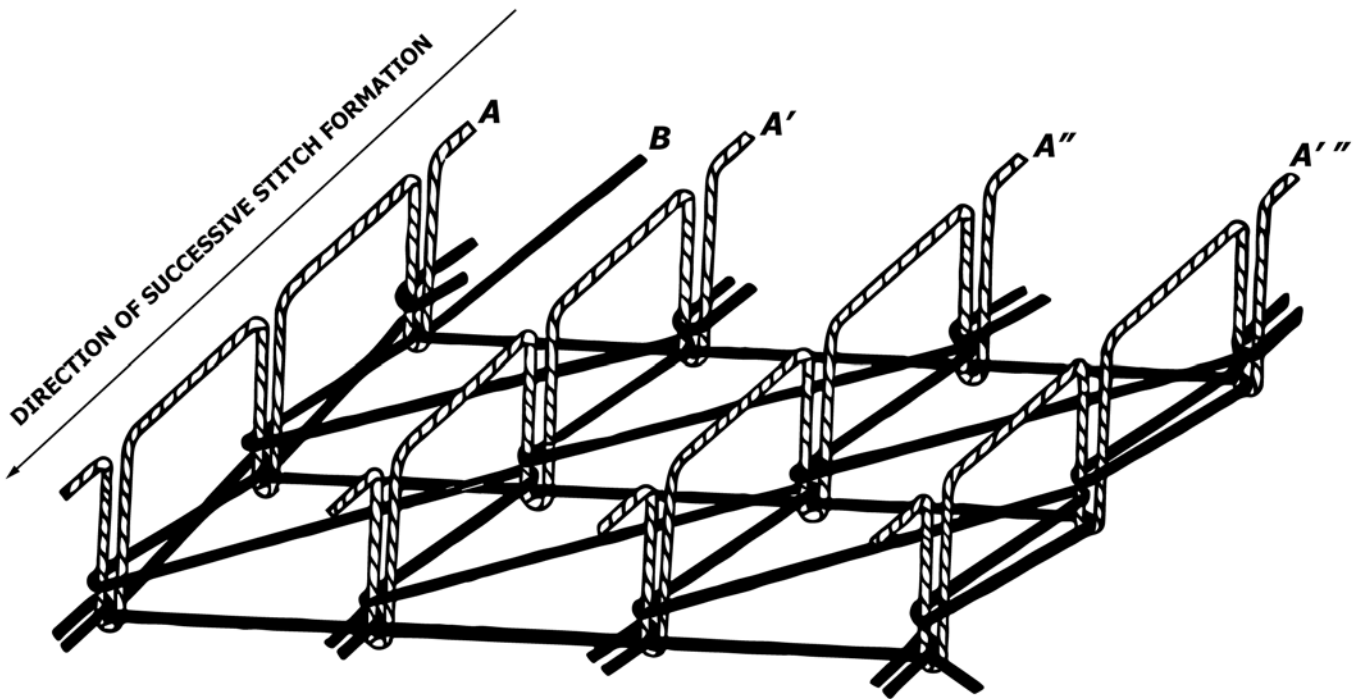

NOTE 1—This type of stitch shall be formed with five threads: four needle threads A, A', A'', and A'''; and one looper thread, B. Loops of threads A, A', A'', and A''' shall pass through the material where they shall be interlooped with the loops of thread B on the underside.

FIG. 34 Stitch Type 408

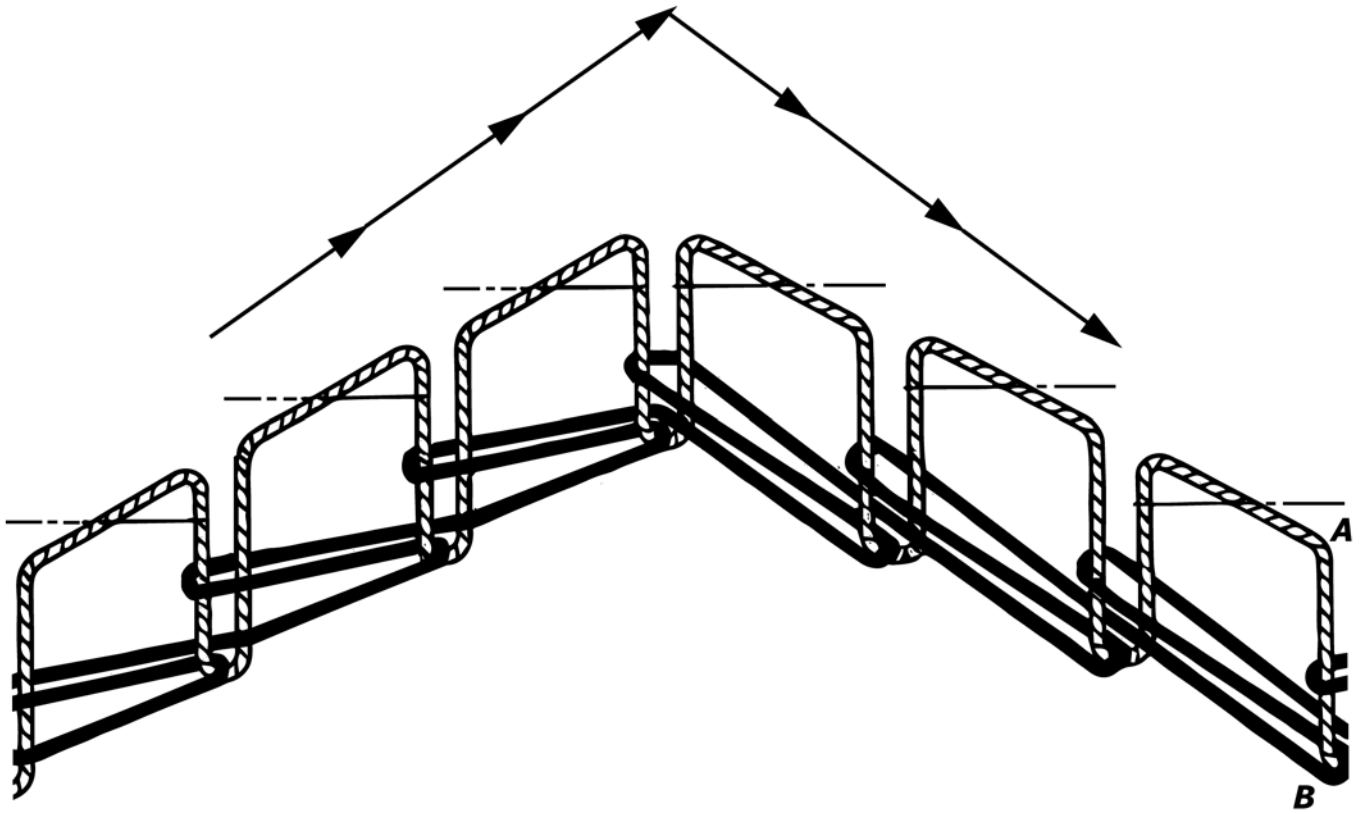

NOTE 1—This type of stitch shall be formed with two threads: one needle thread, A, and one looper thread, B. This stitch is the same as stitch type 404, except that successive groups of three stitches form a symmetrical chainstitch zig zag pattern.

FIG. 35 Stitch Type 409

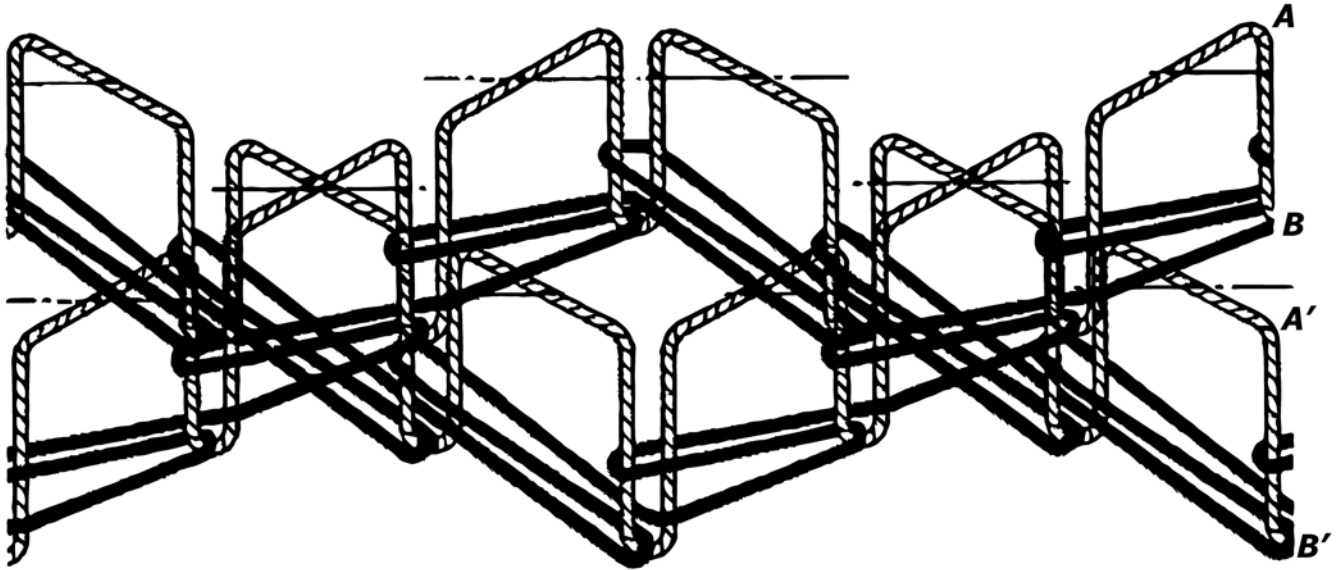
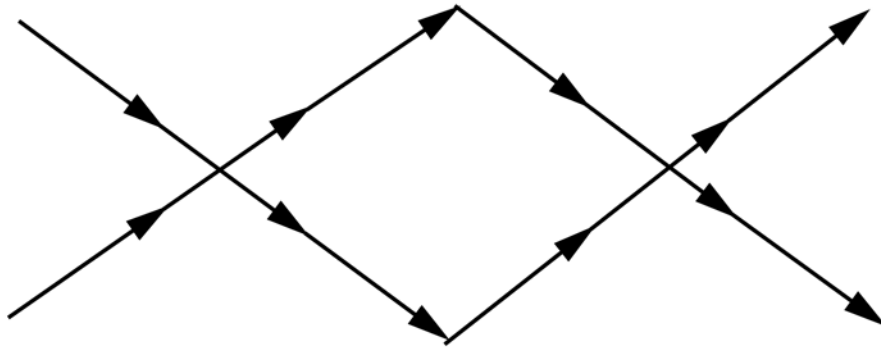

NOTE 1—This type of stitch shall be formed with four threads: two needle threads A, and A', and two looper threads, B and B'. This stitch is the same as stitch type 409, except two successive groups of three stitches form a symmetrical chainstitch zig zag pattern.

FIG. 36 Stitch Type 410

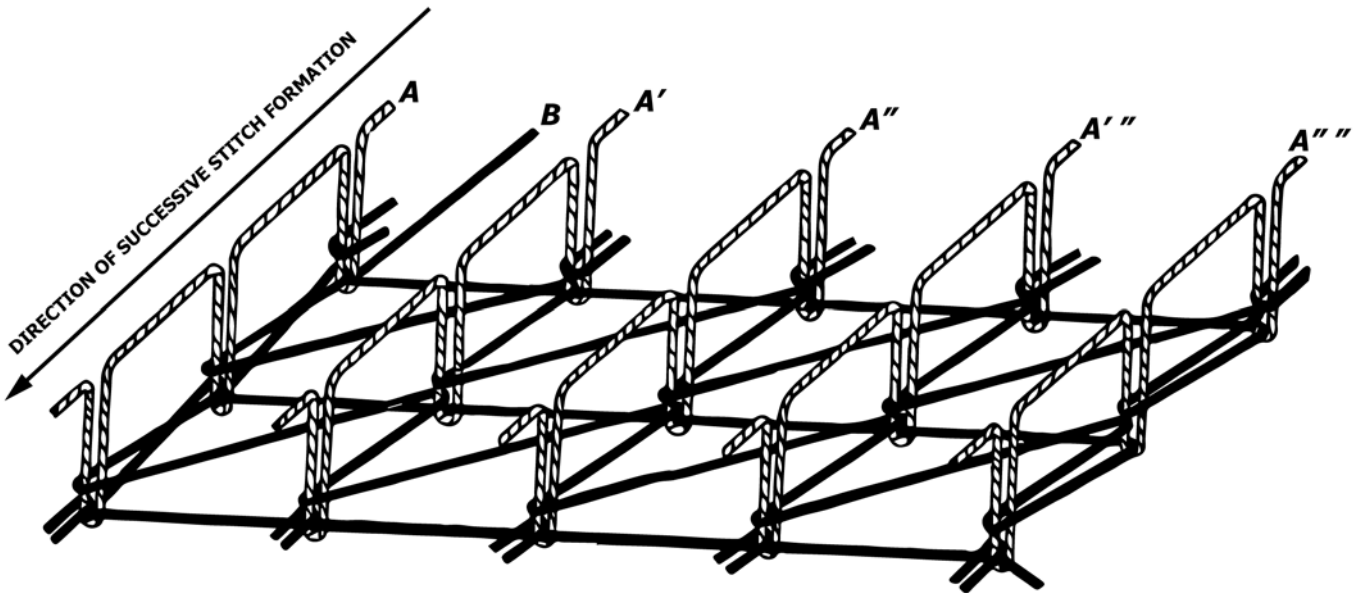

NOTE 1—This type of stitch shall be formed with six threads: five needle threads A, A', A'', A''', and A''''; one looper thread, B. Loops of threads A, A', A'', A''', and A'''' shall pass through the material where they shall be interlooped with the loops of thread B on the underside.

FIG. 37 Stitch Type 411

DIRECTION OF SUCCESSIVE STITCH FORMATION

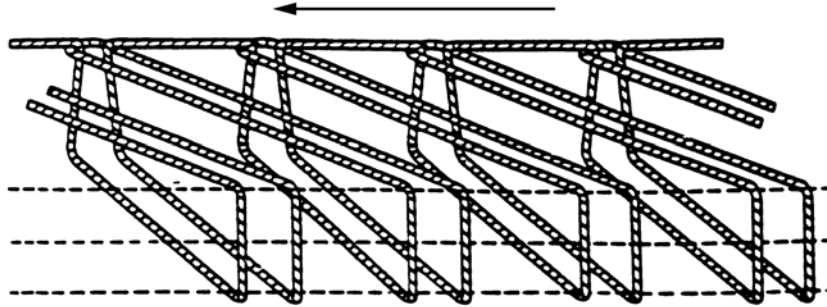

NOTE 1—This type of stitch shall be formed with one needle thread which shall be passed through and around the edge of the material as a loop and interlooped with itself at the point of needle penetration of the stitch on the surface of the material.

FIG. 38 Stitch Type 501

DIRECTION OF SUCCESSIVE STITCH FORMATION

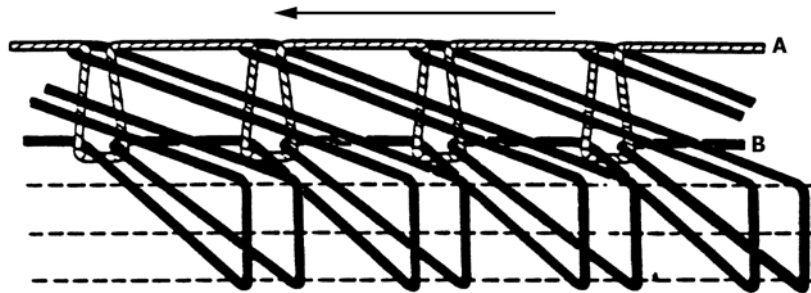

NOTE 1—This type of stitch shall be formed with two threads: one needle thread, A, and one looper thread, B. Loops of thread A shall be passed through the material and interlooped with thread B at the point of penetration on the underside of the material. Loops of thread B shall be brought around the edge of the material and interlooped with thread A at the next stitch on the surface of the material.

FIG. 39 Stitch Type 502

DIRECTION OF SUCCESSIVE STITCH FORMATION

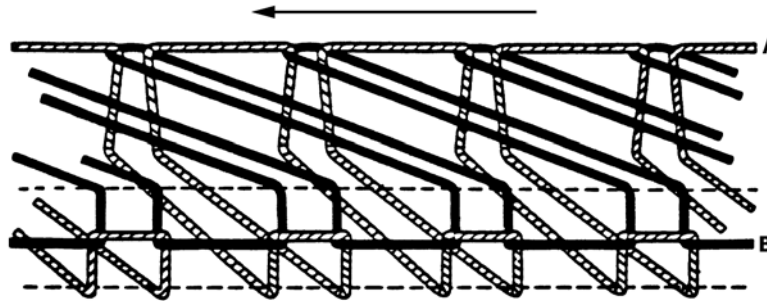

NOTE 1—This type of stitch shall be formed with two threads: one needle thread, A, and one looper thread, B. Loops of thread A shall be passed through the material and brought to the edge where they shall be interlooped with thread B. The loops of thread B shall be extended from this interlooping to the point of needle penetration of the next stitch and there interlooped with thread A.

FIG. 40 Stitch Type 503

DIRECTION OF SUCCESSIVE STITCH FORMATION

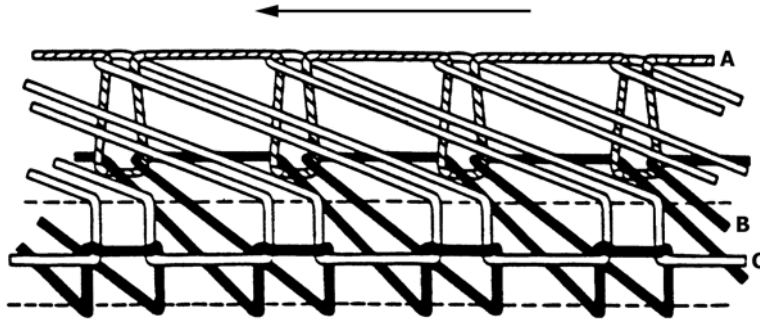

NOTE 1—This type of stitch shall be formed with three threads: one needle thread, A; one looper thread, B; and one cover thread, C. Loops of thread A shall be passed through the material and interlooped with loops of thread B at the point of penetration on the underside of the material. The loops of thread B shall be extended to the edge of the material and there interlooped with loops of thread C. Loops of thread C shall be extended from this interlooping to the point of needle penetration of the next stitch and there interlooped with thread A.

FIG. 41 Stitch Type 504

DIRECTION OF SUCCESSIVE STITCH FORMATION

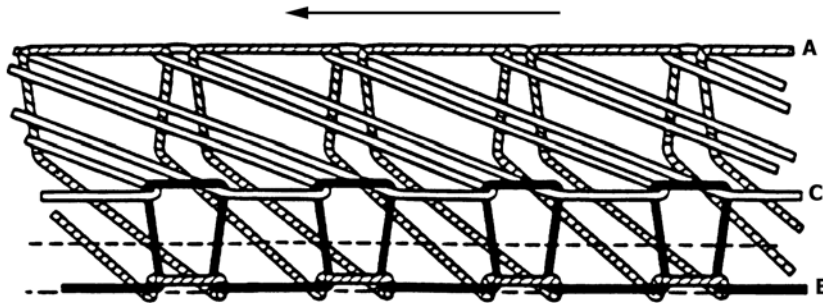

NOTE 1—This type of stitch shall be formed with three threads: one needle thread, A; one looper thread, B; and one cover thread, C. Loops of thread A shall be passed through the material and extended to the edge where they shall be interlooped with loops of thread B. The loops of thread B shall be brought up to the top edge of the material and there interlooped with loops of thread C. The loops of thread C shall be extended to the point of needle penetration of the next stitch and there interlooped with thread A.

FIG. 42 Stitch Type 505

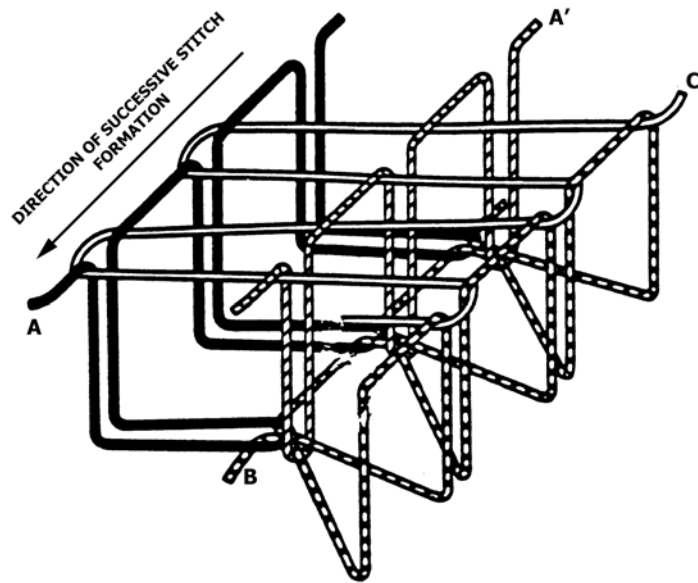

NOTE 1—This type of stitch shall be formed with four threads: two needle threads, A and A'; one looper thread, B; and one cover thread, C. Loops of threads A and A' shall be passed through the material and the loops of thread A shall be extended to the point of needle penetration of the loops of thread A'. Loops of threads A and A' shall be interlooped with loops of thread B at this point. The loops of thread B shall be brought around the edge of the material and interlooped with loops of thread C. The loops of thread C shall be extended to the point of needle penetration of threads A and A', where they shall be entered by the next stitch of those threads.

FIG. 43 Stitch Type 506

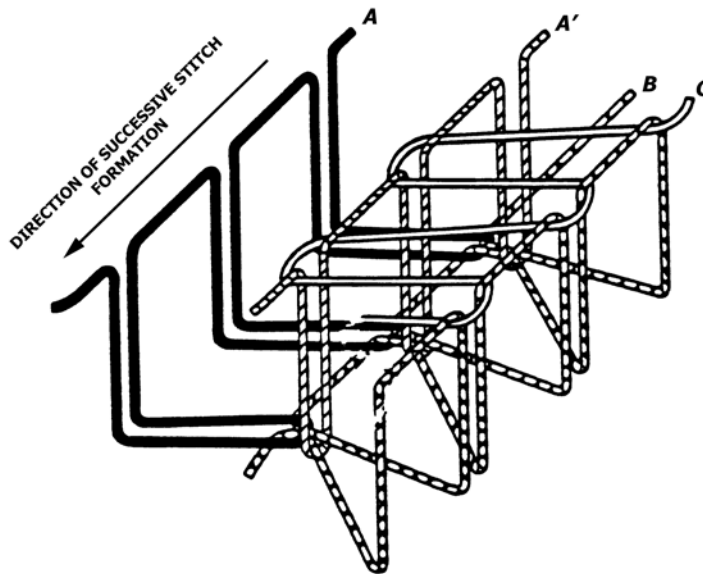

NOTE 1—This type of stitch shall be formed with four threads: two needle threads, A and A'; one looper thread, B; and one cover thread, C. Loops of threads A and A' shall be passed through the material and the loops of thread A shall be extended to the point of needle penetration of the loops of thread A'. Loops of threads A and A' shall be interlooped with loops of thread B at this point. The loops of thread B shall be brought around the edge and interlooped with loops of thread C. The loops of thread C shall be extended to the point of needle penetration of thread A' at the next stitch where they shall be entered by loops of that thread.

FIG. 44 Stitch Type 507

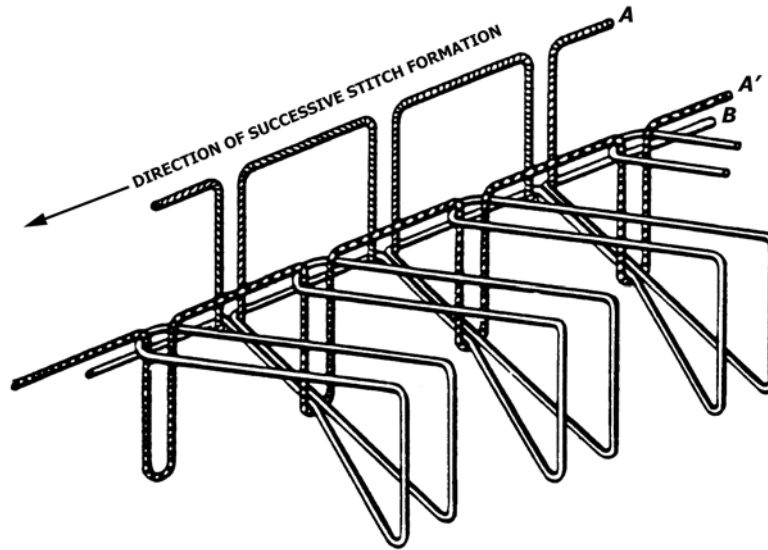

NOTE 1—This type of stitch shall be formed with three threads: two needle threads, A and A', and one looper thread, B. Loops of threads A and A' shall be passed through the material where they shall be interlooped at the lower point of penetration with thread B. Loops of thread B shall be brought around the edge of the material and interlooped with thread A' at the next stitch on the surface of the material.

FIG. 45 Stitch Type 508

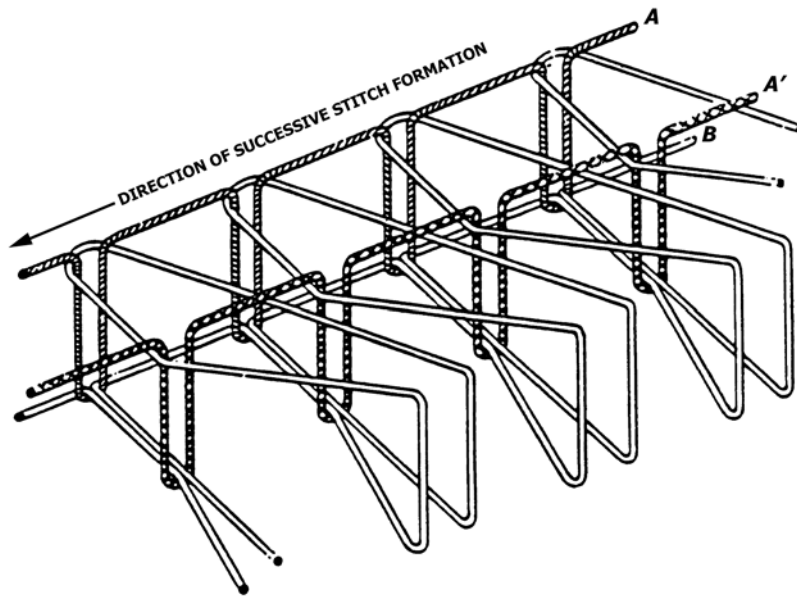

NOTE 1—This type of stitch shall be formed with three threads: two needle threads, A and A', and one looper thread, B. Loops of threads A and A' shall be passed through the material where they shall be interlooped at the lower point of penetration with loops of thread B. Loops of thread B shall be brought around and cast on the surface of the material where they shall be entered by loops of threads A and A'.

FIG. 46 Stitch Type 509

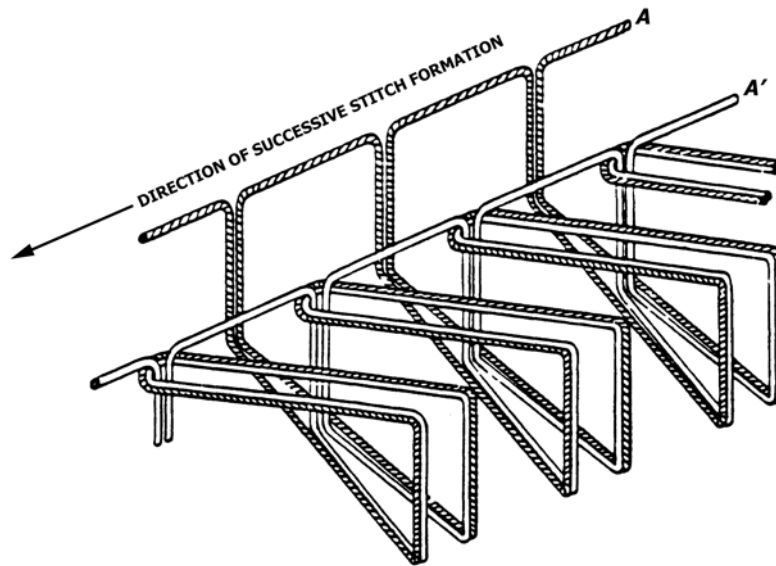

NOTE 1—This type of stitch shall be formed with two needle threads, A and A', which shall be passed through and around the edge to the surface of the material as loops and interlooped with thread A' at the point of needle penetration.

FIG. 47 Stitch Type 510

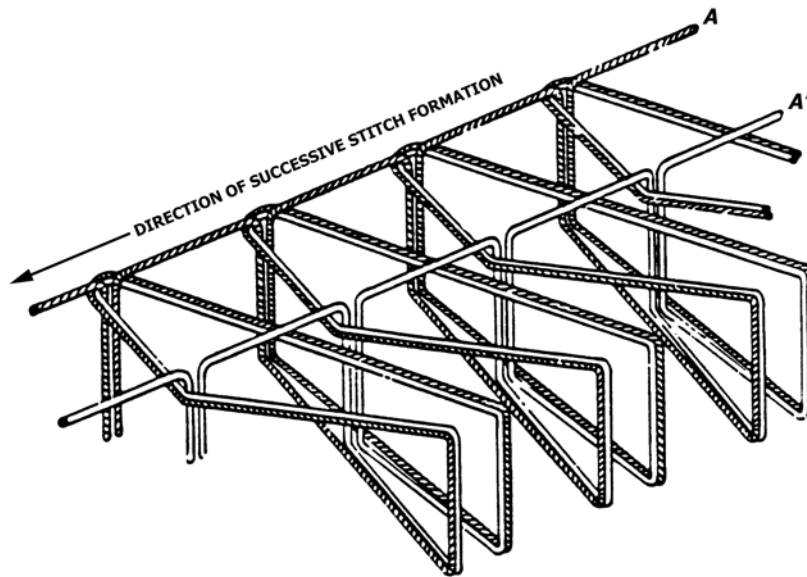

NOTE 1—This type of stitch shall be formed with two needle threads, A and A'. Loops of threads A and A' shall be passed through the material, brought around the edge and cast on the upper surface where they shall be entered by loops of themselves at the point of needle penetration of the next stitch.

FIG. 48 Stitch Type 511

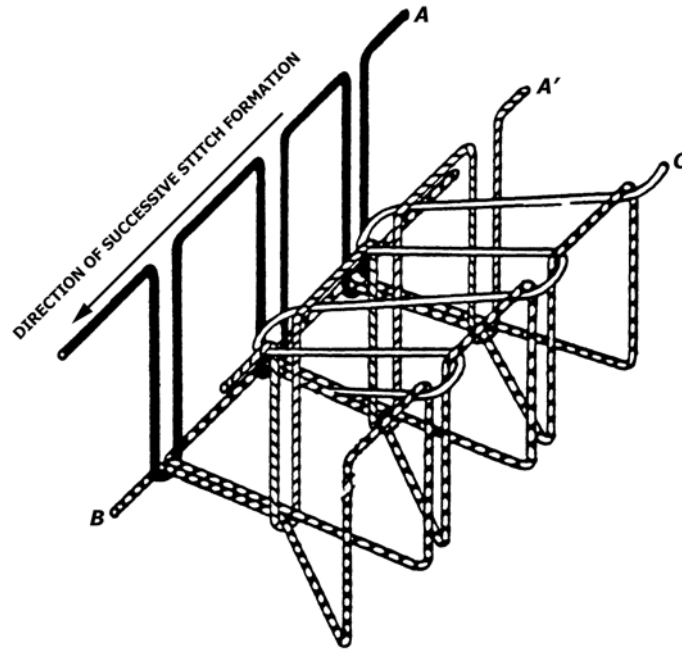

NOTE 1—This type of stitch shall be formed with four threads: two needle threads, A and A'; one looper thread, B; and one cover thread, C. Loops of threads A and A' shall be passed through the material where they shall be interlooped at the lower point of penetration with thread B. The loops of thread B shall be brought around the edge and interlooped with loops of thread C. The loops of thread C shall be extended to the point of needle penetration of thread A' at the next stitch where they shall be entered by loops of that thread.

FIG. 49 Stitch Type 512

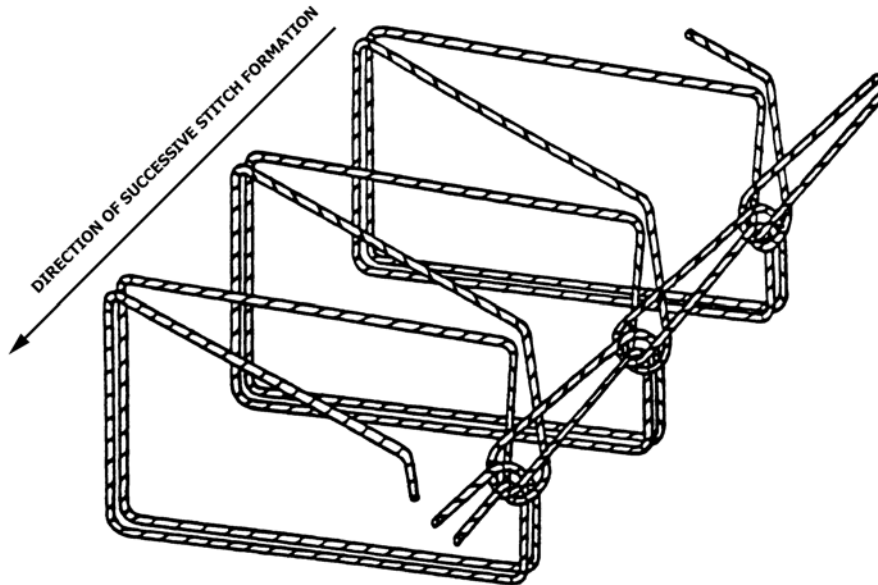

NOTE 1—This type of stitch shall be formed with one needle thread which shall be passed through the material as a loop and brought to the edge, where it shall be passed through a loop formed by the previous stitch and a loop which has been drawn across the upper surface of the material.

FIG. 50 Stitch Type 513

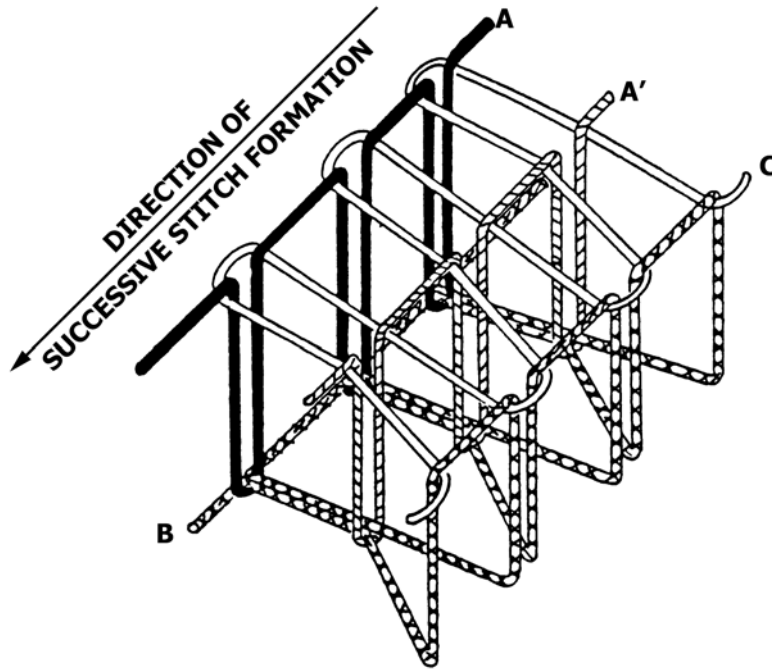

NOTE 1—This type of stitch shall be formed with four threads: two needle threads, A and A'; one looper thread, B; and one cover thread, C. Loops of threads A and A' shall be passed through the material where they shall be interlooped at the lower point of penetration with loops of thread B. The loops of thread B shall be brought around the edge of the material and interlooped with loops of thread C. The loops of thread C shall be extended to the point of needle penetration of threads A and A' at the next stitch where they shall be entered by loops of these threads.

FIG. 51 Stitch Type 514

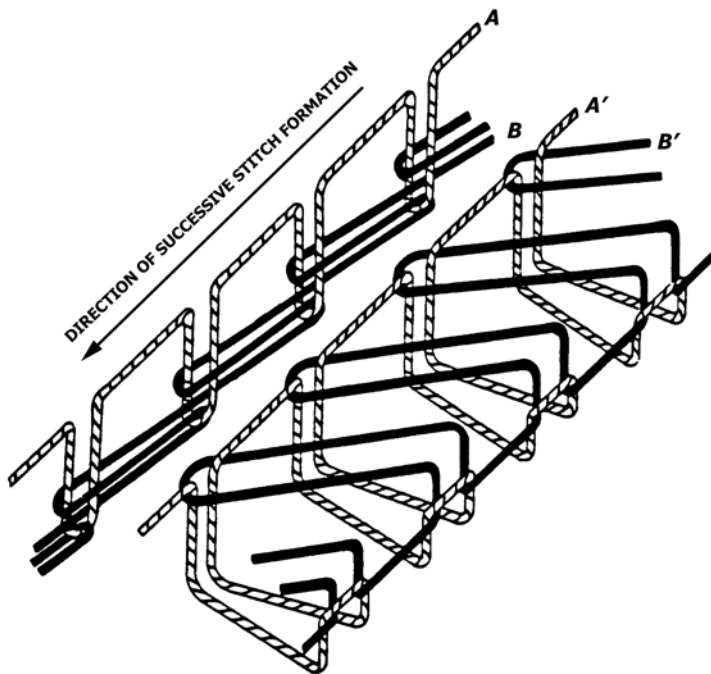

NOTE 1—This type of stitch shall be formed by simultaneously sewing one row of stitch 401 a specified distance from the edge of the material, and one row of stitch type 503 on the edge of the material.

FIG. 52 Stitch Type 515

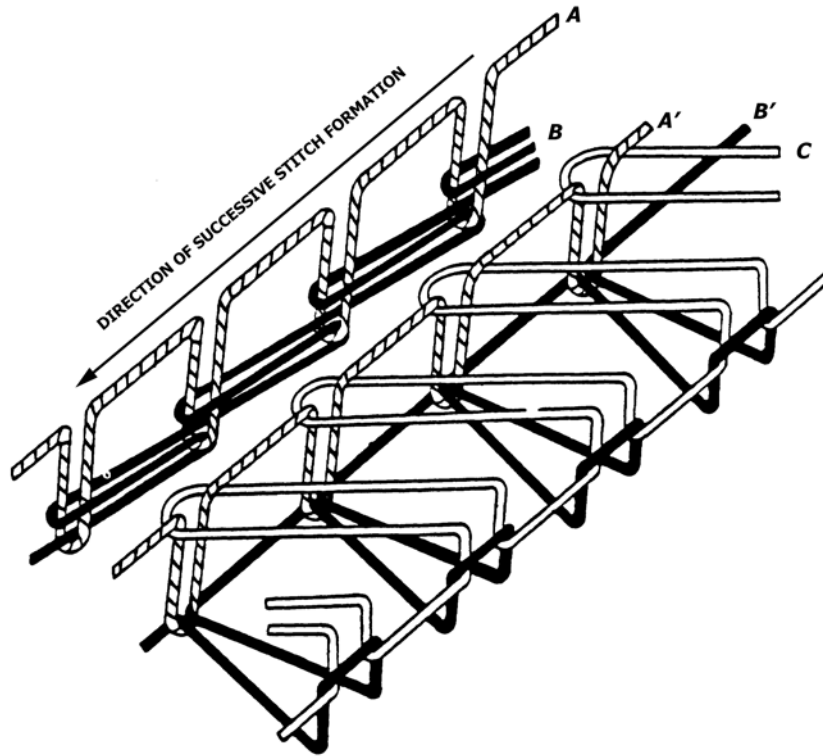

NOTE 1—This type of stitch shall be formed by simultaneously sewing one row of stitch type 401 a specified distance from the edge of the material, and one row of stitch type 504 on the edge of the material.

FIG. 53 Stitch Type 516

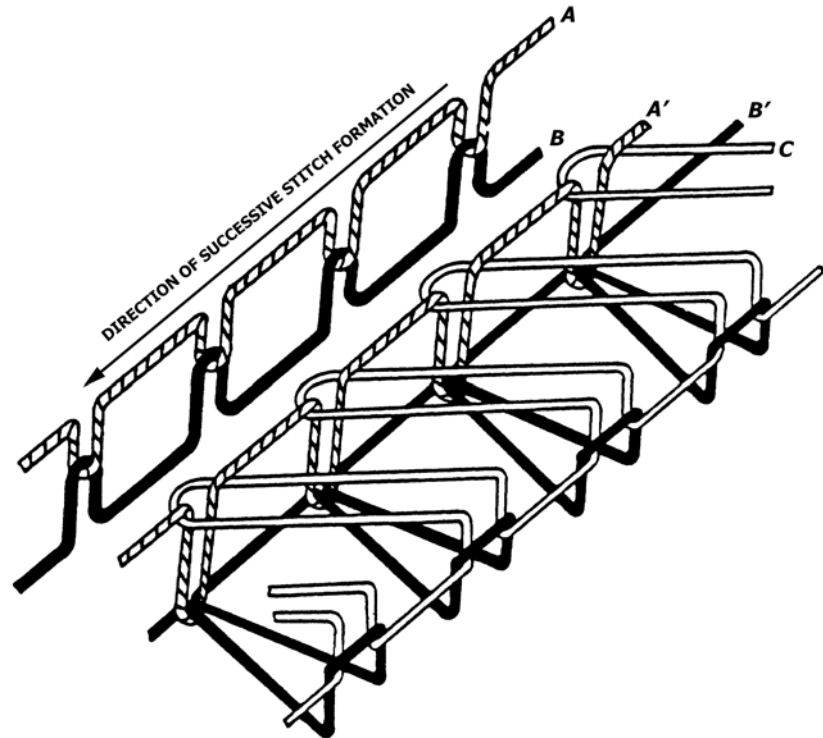

NOTE 1—This type of stitch shall be formed by simultaneously sewing one row of stitch type 301 a specified distance from the edge of the material, and one row of stitch type 504 on the edge of the material.

FIG. 54 Stitch Type 517

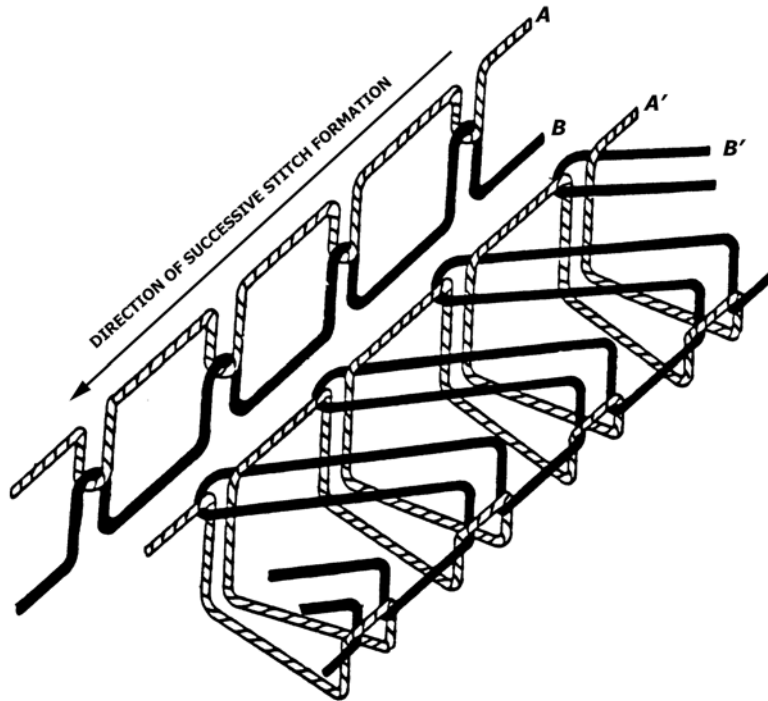

NOTE 1—This type of stitch shall be formed by simultaneously sewing one row of stitch type 301 a specified distance from the edge, and one row of stitch type 503 on the edge of the material.

FIG. 55 Stitch Type 518

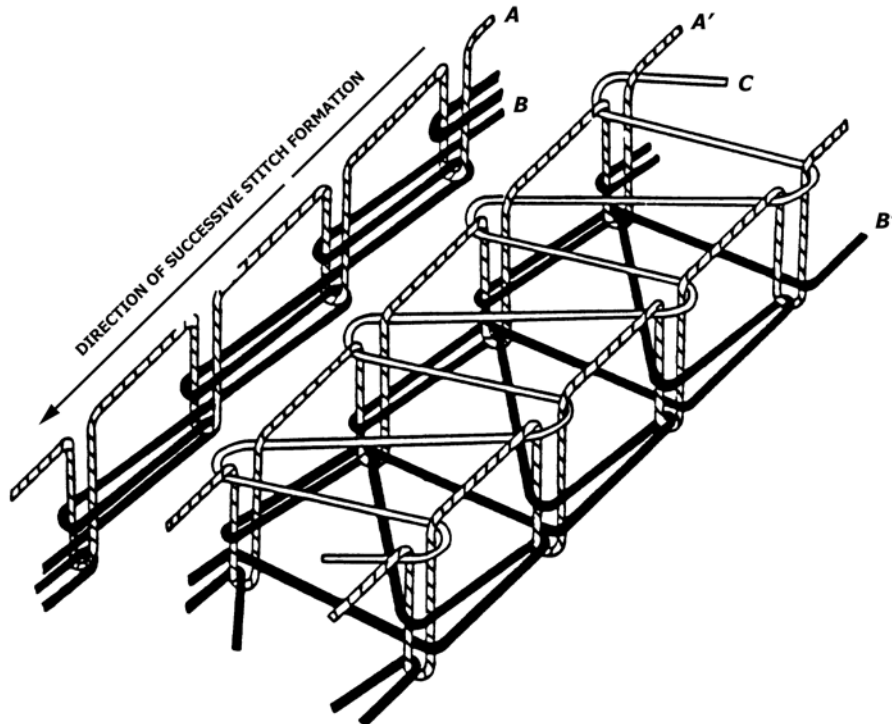

NOTE 1—This type of stitch shall be formed by simultaneously sewing one row of stitch type 401 a specified distance from the edge of the material, and one row of stitch type 602 on the edge of the material.

FIG. 56 Stitch Type 519

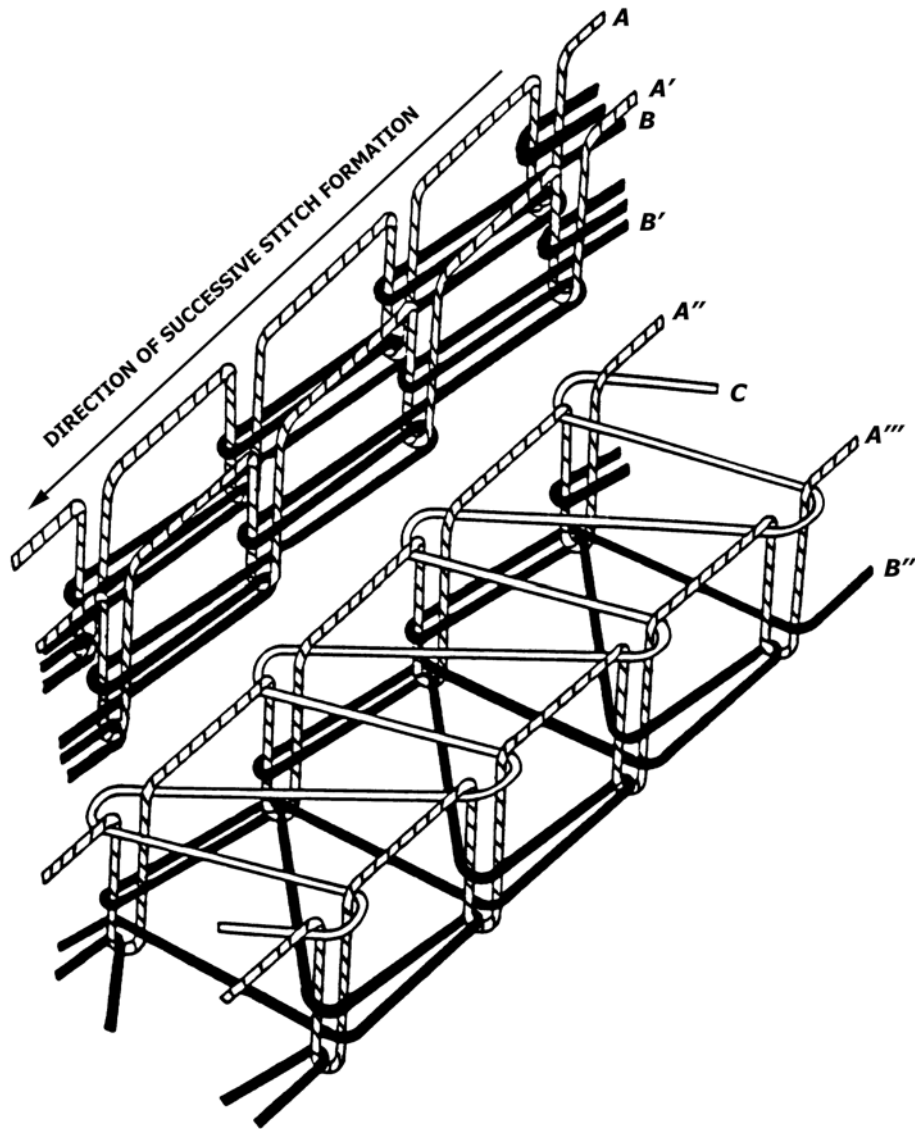

NOTE 1—This type of stitch shall be formed by simultaneously sewing two rows of stitch type 401 a specified distance apart and a specified distance from the edge of the material, and one row of stitch type 602 on the edge of the material.

FIG. 57 Stitch Type 520

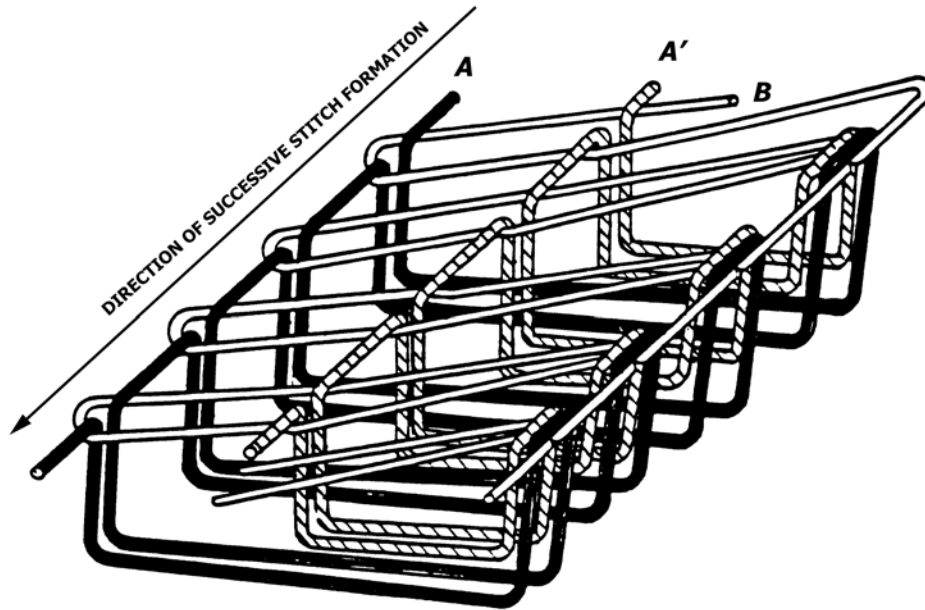

NOTE 1—This type of stitch shall be formed with three threads: two needle threads, A and A', and one looper thread, B. Loops of threads A and A' shall be passed through the material, brought around the edge of the material and interlaced there with thread B. The loops of thread B shall be extended from this interlacing to the points of needle penetration of threads A and A' where they shall be entered by the next stitch of those threads.

FIG. 58 Stitch Type 521

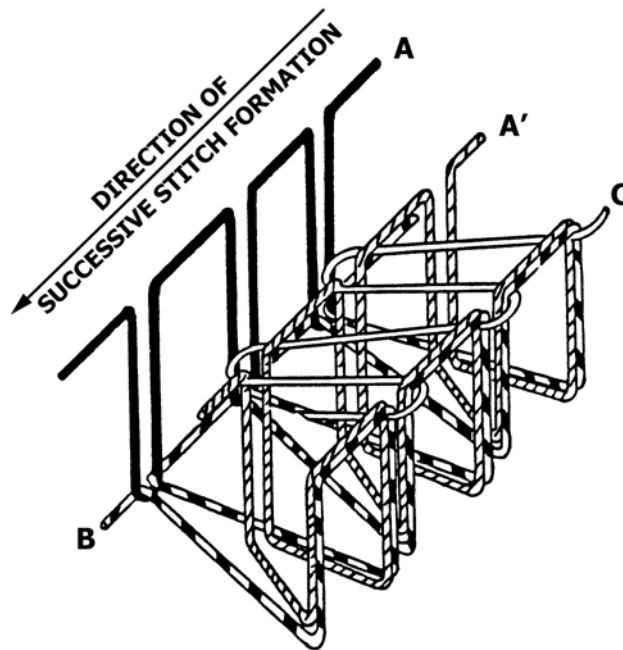

NOTE 1—This type of stitch shall be formed with four threads: two needle threads, A and A¹; one looper thread, B and one looper thread C. Loops of thread A and A¹ shall be interlooped at the lower point of penetration with thread B. The loops of thread A¹ and B shall be brought around the edge and interlooped with loops of thread C. The loops of thread C shall be extended to the next stitch where they shall be entered by loops of that thread.

FIG. 59 Stitch Type 522

DIRECTION OF SUCCESSIVE STITCH FORMATION

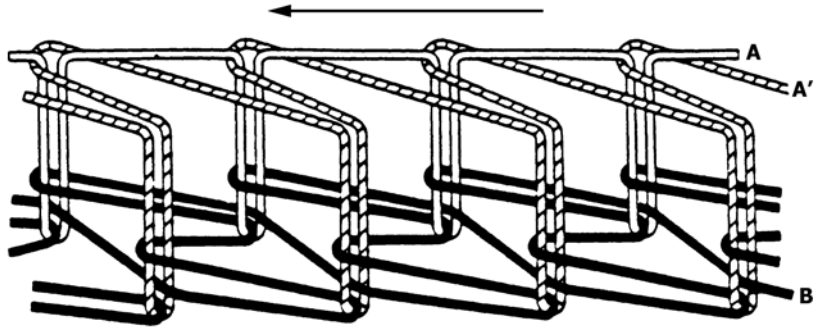

NOTE 1—This type of stitch shall be formed with three threads; two needle threads, A and A', and one looper thread, B. Loops of threads A and A' shall be passed through the material where they shall be interlooped with thread B on the underside. Loops of thread A' shall be extended across the material to the point of needle penetration of the next stitch of thread A where they shall be entered by a loop of that thread as it enters the fabric to make the next stitch.

FIG. 60 Stitch Type 601

DIRECTION OF SUCCESSIVE STITCH FORMATION

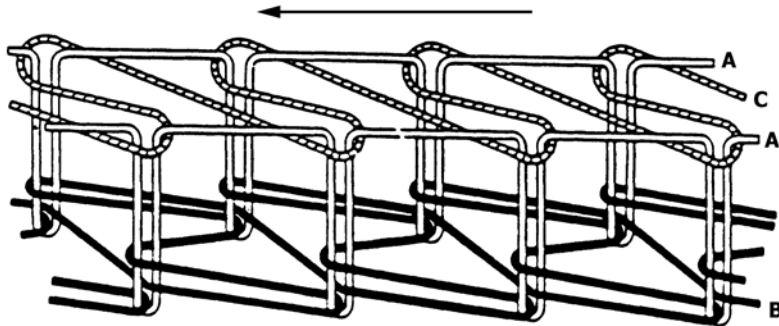

NOTE 1—This type of stitch shall be formed with four threads: two needle threads, A and A'; one looper thread, B; and one cover thread, C. Loops of threads A and A' shall be passed through loops of thread C already cast across the top surface of the material, and then through the material where they shall be interlooped with loops of thread B on the underside.

FIG. 61 Stitch Type 602

DIRECTION OF SUCCESSIVE STITCH FORMATION

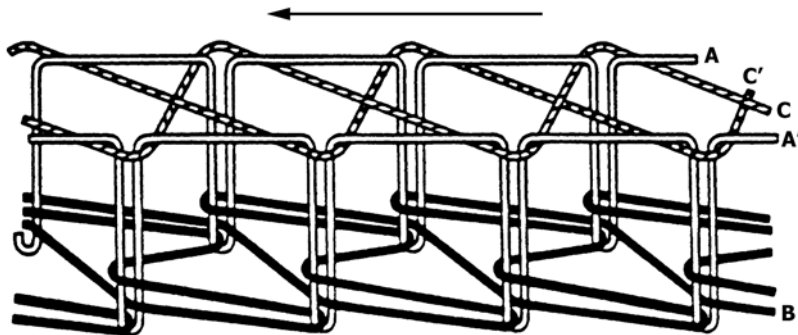

NOTE 1—This type of stitch shall be formed with five threads: two needle threads, A and A'; one looper thread, B; and two cover threads, C and C'. Loops of threads A and A' shall be passed through loops of threads C and C' already cast across the surface of the material and then through the material and interlooped with loops of thread B on the underside of the material.

FIG. 62 Stitch Type 603

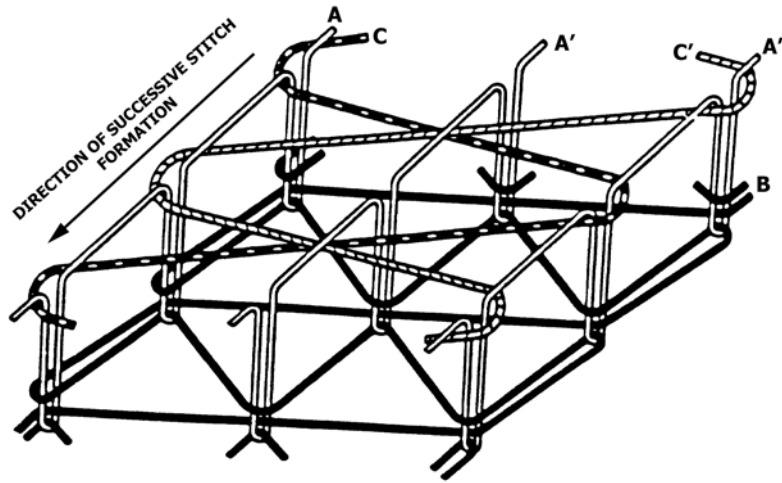

NOTE 1—This type of stitch shall be formed with six threads: three needle threads, A, A' and A''; one looper thread, B; and two cover threads, C and C'. Loops of threads A, A' and A'' shall be passed through loops of threads C and C' already cast across the surface of the material, and then through the material where they shall be interlooped with thread B on the underside.

FIG. 63 Stitch Type 604

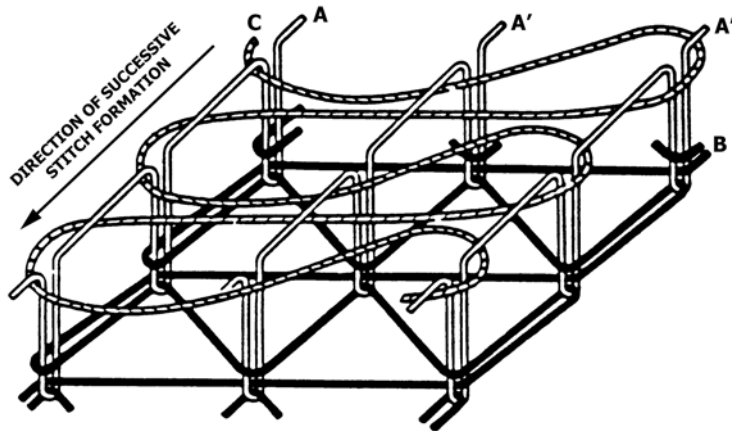

NOTE 1—This type of stitch shall be formed with five threads: three needle threads, A, A', and A''; one looper thread, B; and one cover thread, C. Loops of threads A, A', and A'' shall be passed through loops of thread C already cast on the top surface of the material and then through the material where they shall be interlooped with loops of thread B on the underside.

FIG. 64 Stitch Type 605

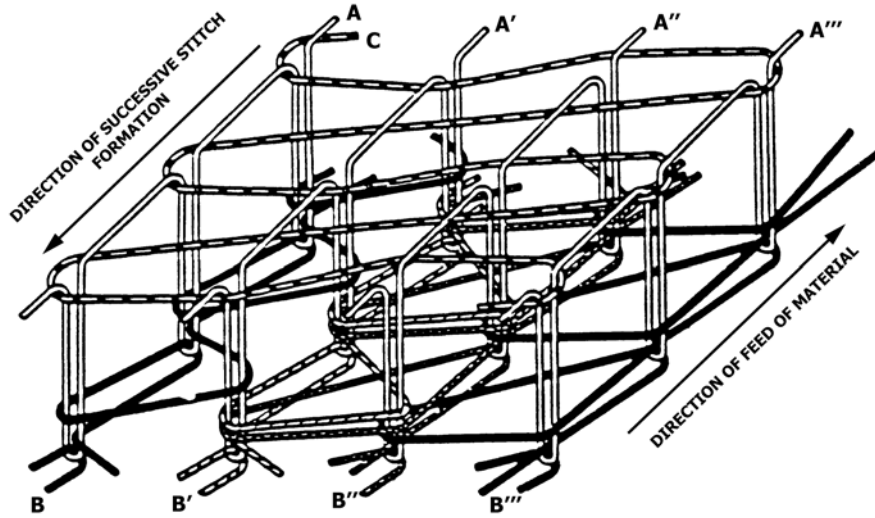

NOTE 1—This type of stitch shall be formed with nine threads: four needle threads, A, A', and A'', and A'''; four looper threads, B, B', B'', and B'''; and one cover thread, C. Loops of threads A, A', A'', and A''' shall be passed through loops of thread C already cast on the top surface of the material, and then through the material where they shall be interlooped with loops of the B threads on the underside as follows: A and A' with B; A' and A'' with B' and B''; A'' and A''' with B'''.

FIG. 65 Stitch Type 606

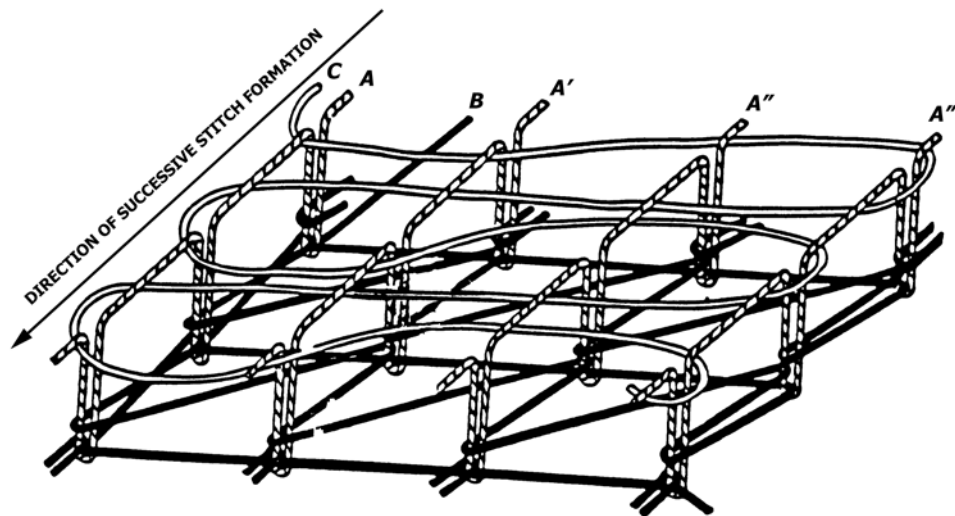

NOTE 1—This type of stitch shall be formed with six threads: four needle threads, A, A', A'', and A'''; one looper thread, B; and one cover thread, C. Loops of threads A, A', A'', and A''' shall be passed through loops of thread C already cast on the surface of the material, and then through the material where they shall be interlooped with loops of thread B on the underside.

FIG. 66 Stitch Type 607

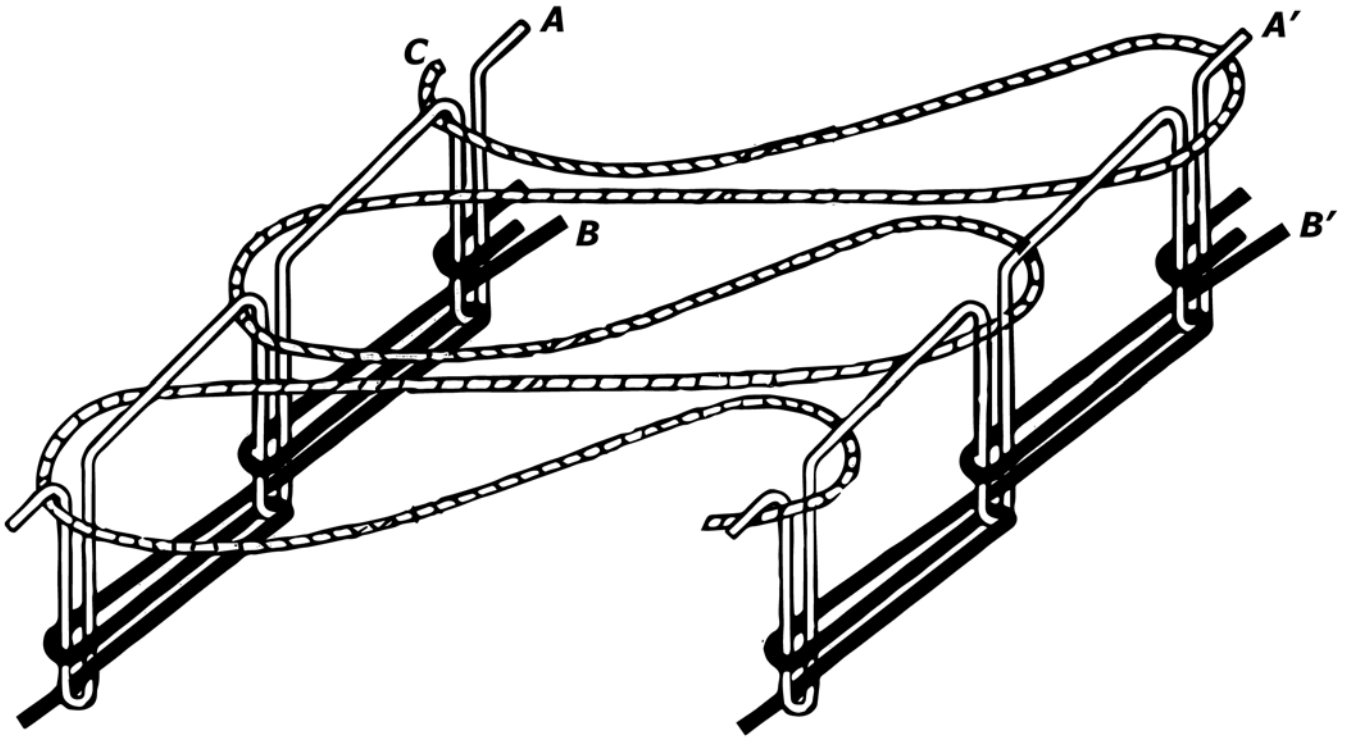

NOTE 1—This type of stitch shall be formed with five threads: two needle threads, A and A'; two looper threads, B and B'; and one cover thread, C. Loops of threads A and A' shall be passed through loops of thread C cast across the top surface of the material, and then through the material where they shall be interlooped with loops of thread B and B' on the underside.

FIG. 67 Stitch Type 608

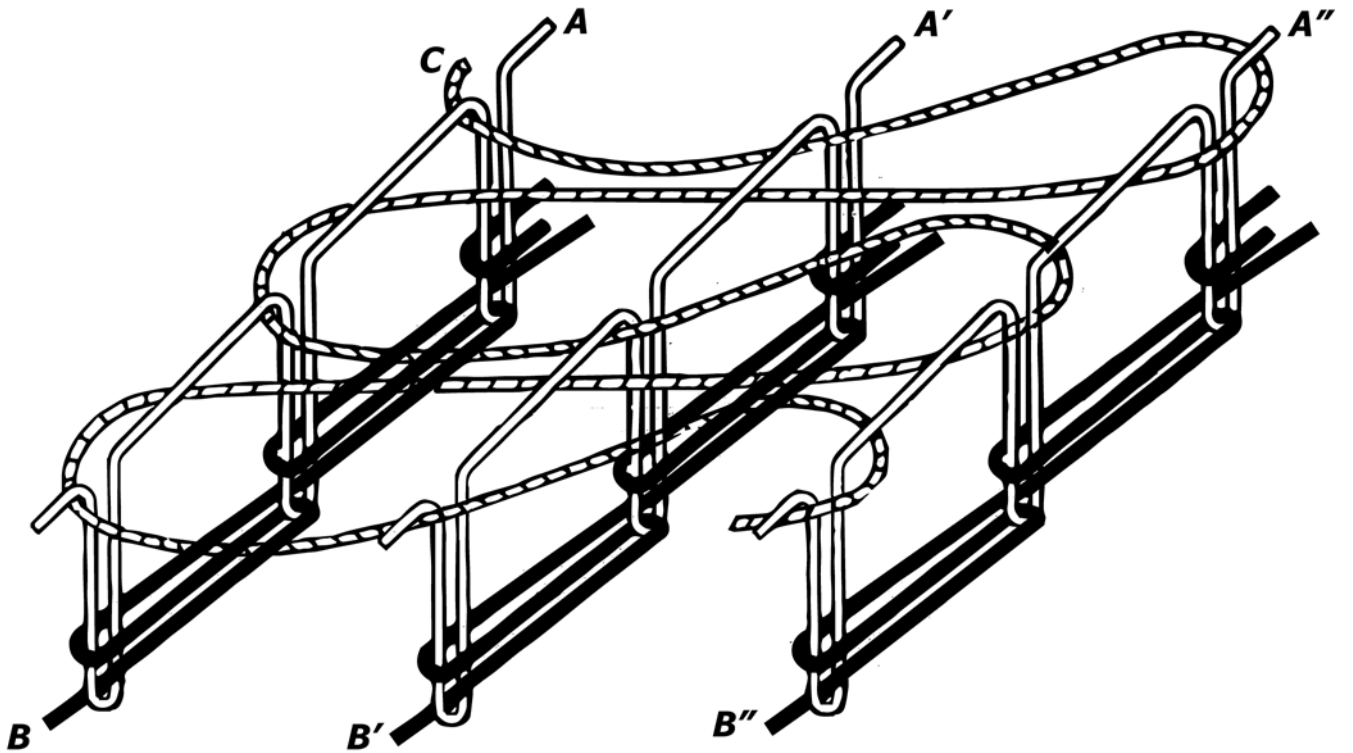

NOTE 1—This type of stitch shall be formed with seven threads: three needle threads, A, A', and A''; three looper threads, B, B', and B''; and one cover thread, C. Loops of threads A, A', and A'' shall pass through loops of thread C cast on the top surface of the material and then through the material where they shall be interlooped with loops of threads B, B', and B'' on the underside.

FIG. 68 Stitch Type 609

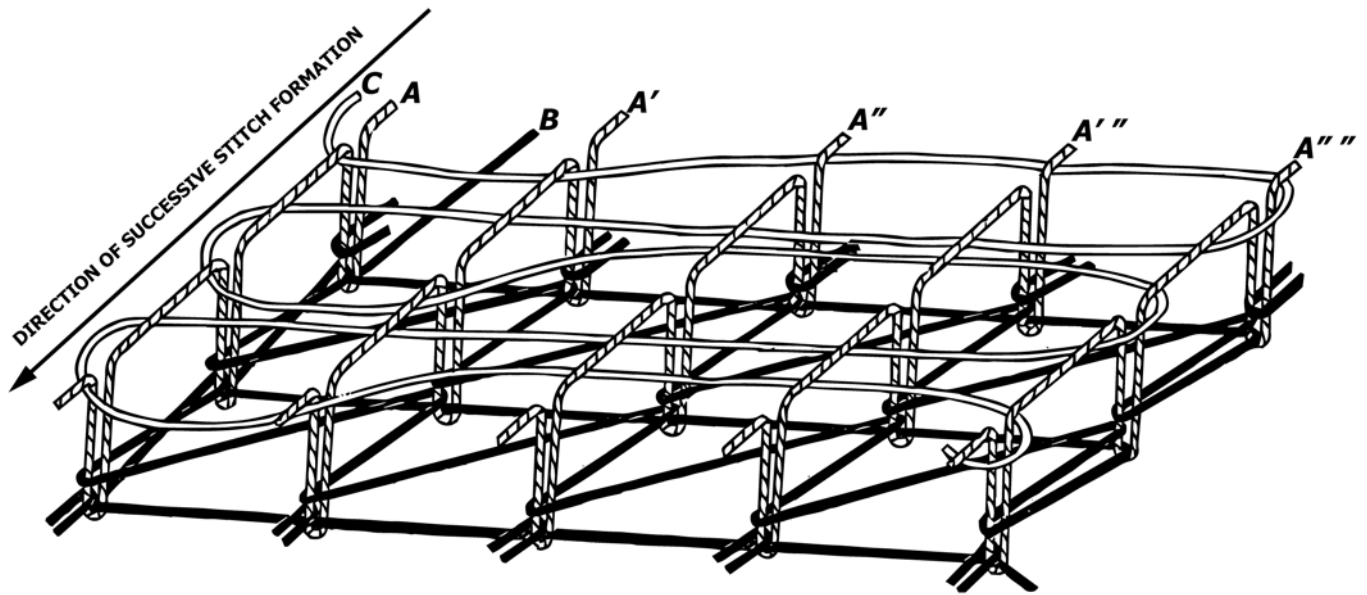

NOTE 1—This type of stitch shall be formed with seven threads: five needle threads, A, A', A'', and A'''; one looper thread, B; and one cover thread, C. Loops of threads A, A', A'', and A''' shall be passed through loops of thread C cast on the surface of the material, and then through the material where they shall be interlooped with loops of thread B on the underside.

FIG. 69 Stitch Type 610

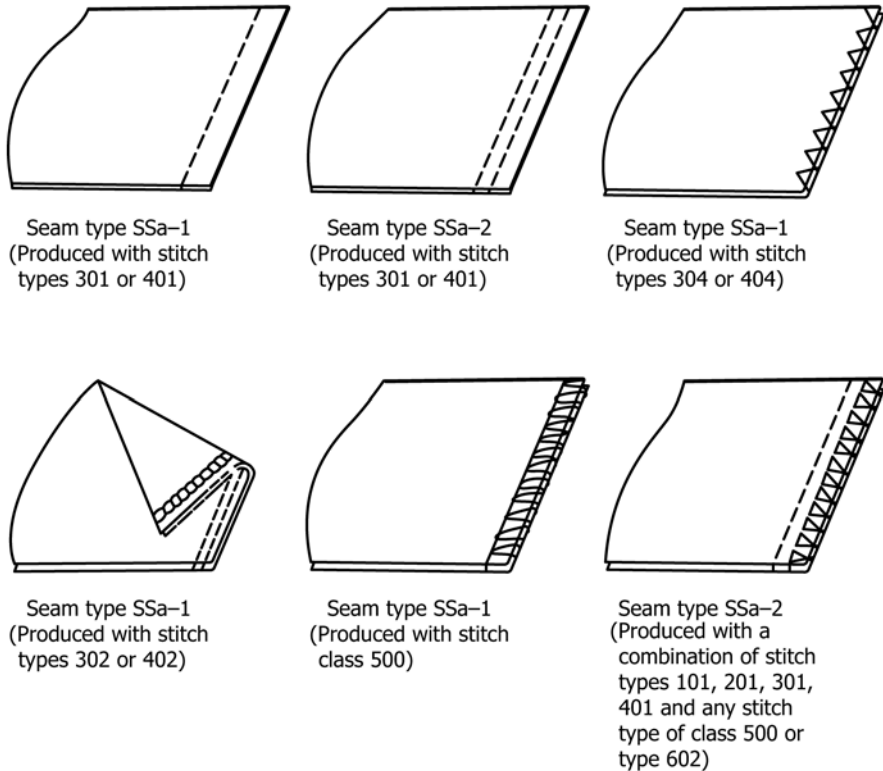

NOTE 1—This type of seam shall be formed by superimposing two or more plies of material and seaming them with one or more rows of stitches a specified distance from their edges.

FIG. 70 Seam Type SSa

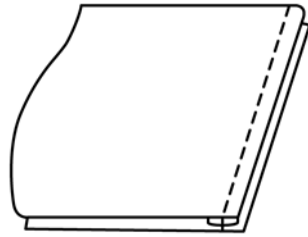

Seam type SSb-1

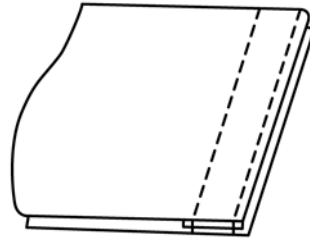

Seam type SSb-2

NOTE 1—This type of seam shall be formed by superimposing two plies of material, turning in the edge of one ply a specified distance to the inside and seaming the plies with one or more rows of stitches.

FIG. 71 Seam Type SSb

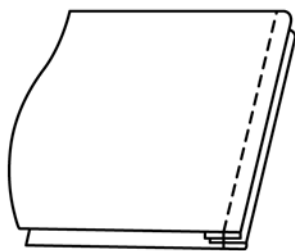

Seam type SSc-1

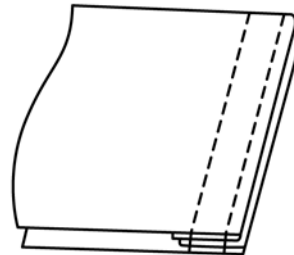

Seam type SSc-2

NOTE 1—This type of seam shall be formed by superimposing two plies of material, turning the edges of both plies a specified distance to the inside and seaming through the turned edges with one or more rows of stitches a specified distance from the edges.

FIG. 72 Seam Type SSc

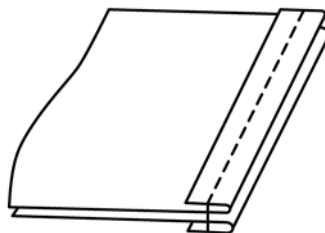

Seam type SSd-1

NOTE 1—This type of seam shall be formed by superimposing two plies of material, turning the edge of both plies a specified distance outwardly and seaming with one or more rows of stitches.

FIG. 73 Seam Type SSd-1

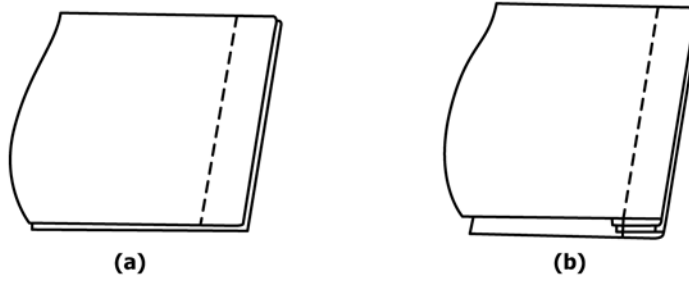

Seam type SSe-2

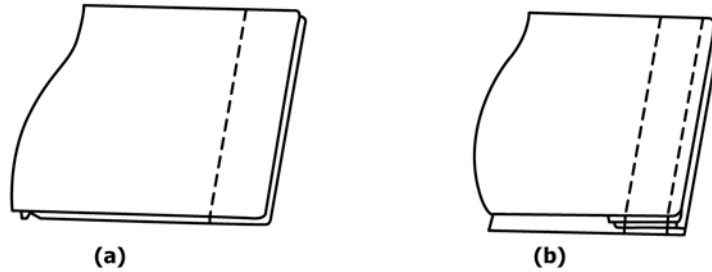

Seam type SSe-3

NOTE 1—This type of seam shall be formed by:
 (a) superimposing two plies of material and seaming with one row of stitches a specified distance from the edge, (seam type SSa-1), and
 (b) turning both plies of material at the first seaming to cover the raw edges and seaming with one or more rows of stitches through the folded edges.

FIG. 74 Seam Type SSe

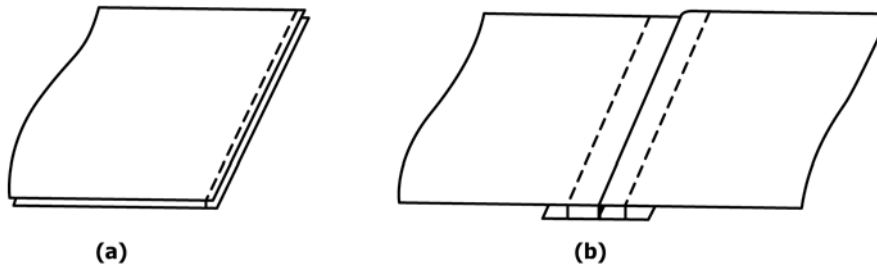

Seam type SSf-3

NOTE 1—This type of seam shall be formed by:
 (a) superimposing two plies of material and seaming with one row of stitches, a specified distance from the edge (Seam Type SSa-1), and
 (b) opening both plies of the material and seaming a reinforcing tape over the raw edges of the material with two rows of stitches a specified distance apart.

FIG. 75 Seam Type SSf-3

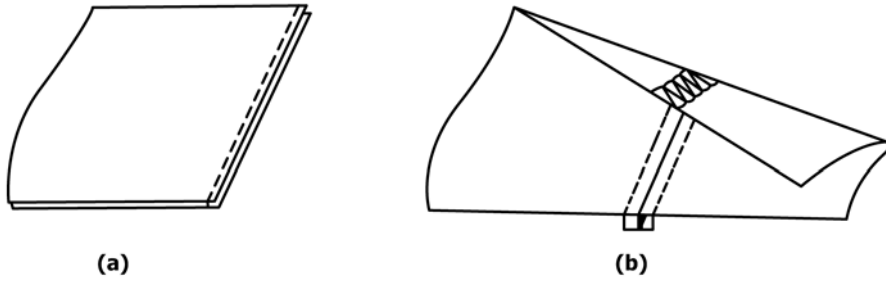

Seam type SSh-2

NOTE 1—This type of seam shall be formed by:
 (a) superimposing two plies of material and seaming with one row of stitches, a specified distance from the edge (Seam Type SSa-1), and
 (b) opening the plies of material and sewing with a row of covering stitches over the trimmed edges.

FIG. 76 Seam Type SSh-2

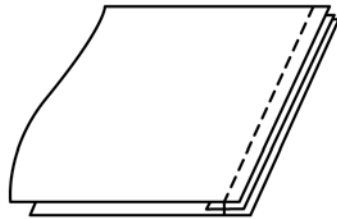

Seam type SSj-1

NOTE 1—This type of seam shall be formed by superimposing two or more plies of material, inserting a plain narrow strip of material between and seaming with one or more rows of stitches a specified distance from the near edge.

FIG. 77 Seam Type SSj-1

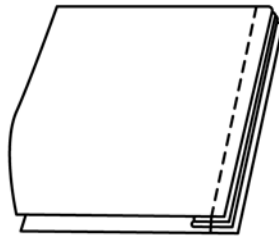

Seam type SSK-1

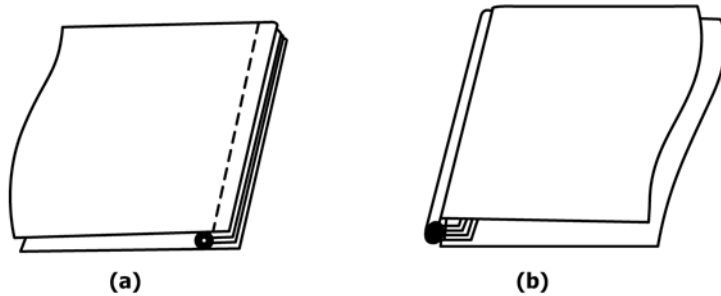

Seam type SSK-1
 (with cord)

NOTE 1—This type of seam shall be formed by inserting a folded strip of material, with or without a cord as specified, between two superimposed plies of material and seaming with one or more rows of stitches.

FIG. 78 Seam Type SSK-1

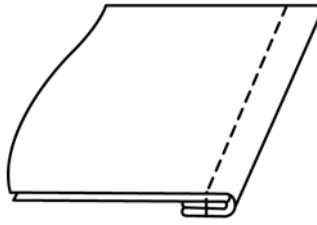

Seam type SSI-1

NOTE 1—This type of seam shall be formed by superimposing one ply of material on another a sufficient distance from the edge to permit turning the edge of one ply of the material under and in, a specified distance around the edge of the other ply, and seaming with one row of stitches.

FIG. 79 Seam Type SSI-1

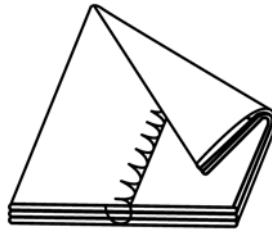

Seam type SSm-1

NOTE 1—This type of seam shall be formed by superimposing two or more plies of material and seaming with one row of stitches in such a manner that the thread passes only partially through the thickness of the last or outer ply. The thread shall not show on the outer side of the last ply unless otherwise specified.

FIG. 80 Seam Type SSm-1

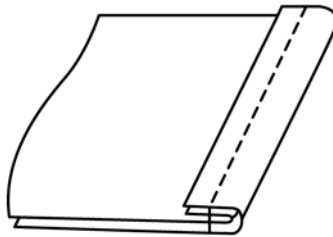

Seam type SSn-1

NOTE 1—This type of seam shall be formed by superimposing two or more plies of material, folding both the edges back over the body of material a specified distance and seaming with one row of stitches.

FIG. 81 Seam Type SSn-1

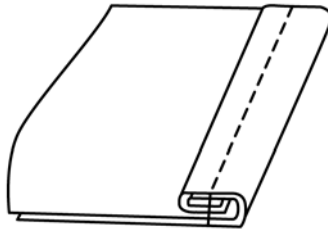

Seam type SSp-1

NOTE 1—This type of seam shall be formed by superimposing two or more plies of material, turning the edges back over the body of material and in, under that fold a specified distance, and seaming with one row of stitches.

FIG. 82 Seam Type SSp-1

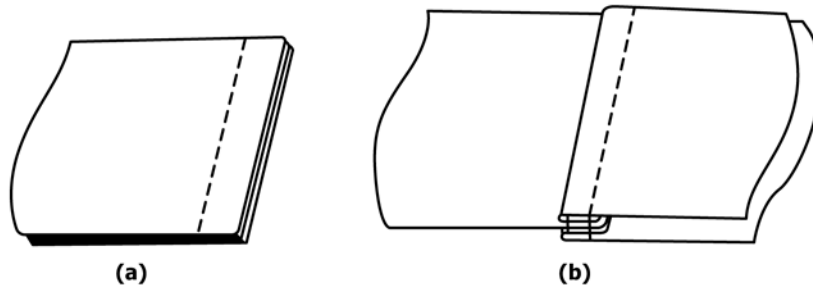

Seam type SSq-2

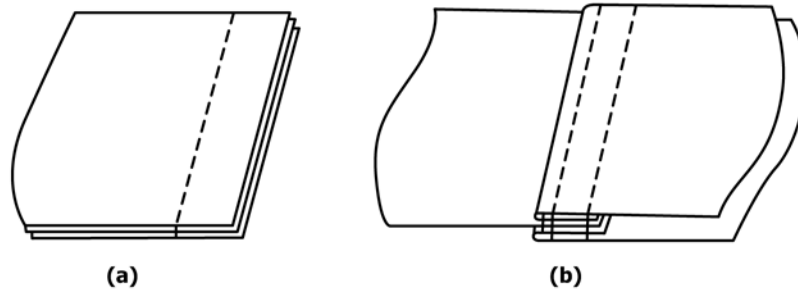

Seam type SSq-3

NOTE 1—This type of seam shall be formed by:
 (a) superimposing three or more plies of material and seaming with one row of stitches a specified distance from the edge (seam type SSa-1), and
 (b) turning the two outer plies back over their edges and seaming with one or more rows of stitches.

FIG. 83 Seam Type SSq

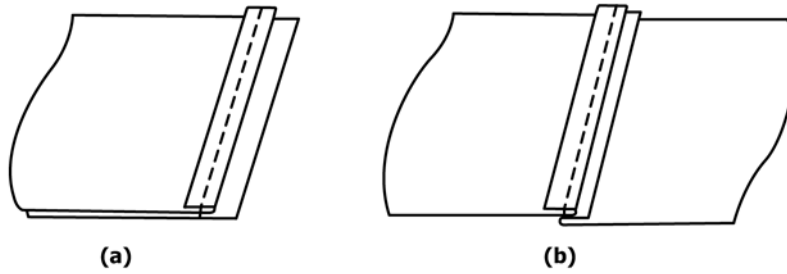

Seam type SSr-1

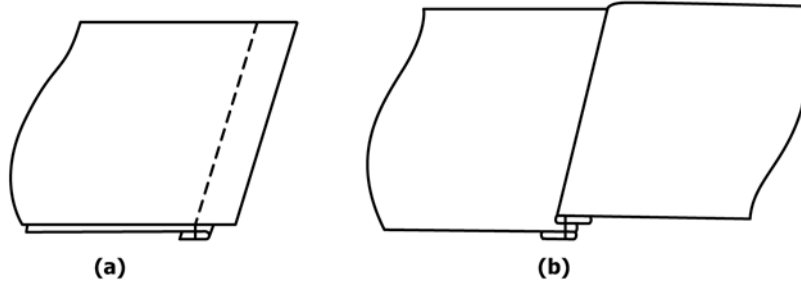

Seam type SSr-1 (Inverted)

NOTE 1—This type of seam shall be formed by superimposing two plies of material, turning the edge of one ply of material and seaming through the turned edge and plies of material with one row of stitches.

FIG. 84 Seam Type SSr-1

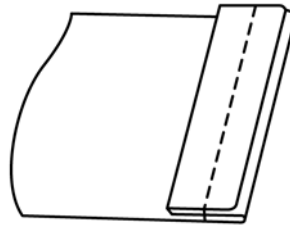

Seam type SSs-1

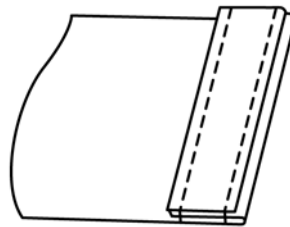

Seam type SSs-2

NOTE 1—This type of seam shall be formed by superimposing a tape, webbing or narrow piece of fabric over the turned edge of a ply or plies of material and seaming with one or more rows of stitches through the turned edge.

FIG. 85 Seam Type SSs

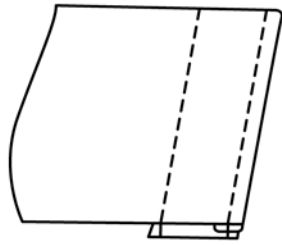

Seam type SSt-2

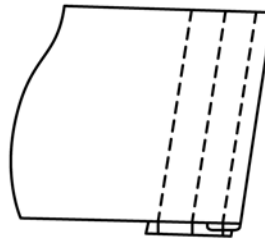

Seam type SSt-3

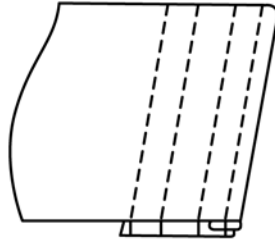

Seam type SSt-4

NOTE 1—This type of seam shall be formed by superimposing a ply or plies of material with the outer edge turned, on a tape, webbing or narrow strip of fabric and seaming with two or more rows of stitches, with only the row nearest the folded edge going through the fold.

FIG. 86 Seam Type SSt

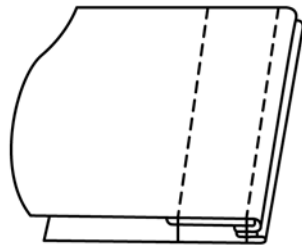

Seam type SSu-2

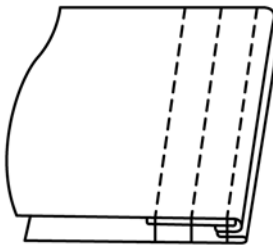

Seam type SSu-3

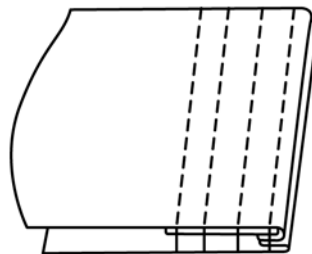

Seam type SSu-4

NOTE 1—This type of seam shall be formed by turning the edges of two plies of material inwardly, inserting a tape or strip of material within the inturned upper ply, and stitching with two or more rows of stitches, with only the row nearest the folded edge going through the folds.

FIG. 87 Seam Type SSu

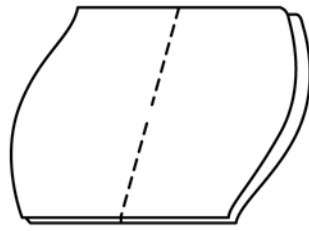

Seam type SSv-1

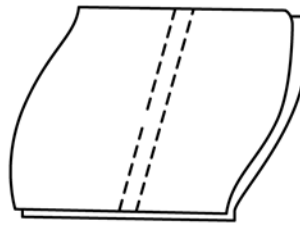

Seam type SSv-2

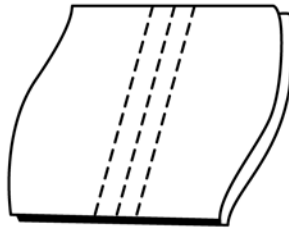

Seam type SSv-3

NOTE 1—This type of seam shall be formed by superimposing and seaming two or more plies of material with one or more rows of stitches where evenly spaced lines of stitches are required in the body of the materials, as in quilting comforters, clothing linings, etc.

FIG. 88 Seam Type SSv

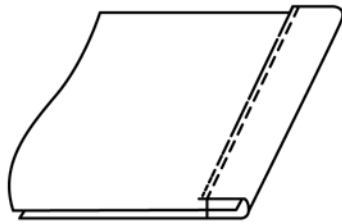

(a)

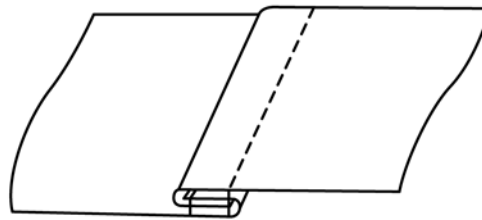

(b)

Seam type SSw-2

NOTE 1—This type of seam shall be formed by:

- (a) superimposing two pieces of material, turning the edge of one ply of material over the edge of the second ply, and seaming with one row of stitches, and
- (b) turning back the body of the upper ply over the folded lower ply and seaming with one row of stitches.

FIG. 89 Seam Type SSw-2

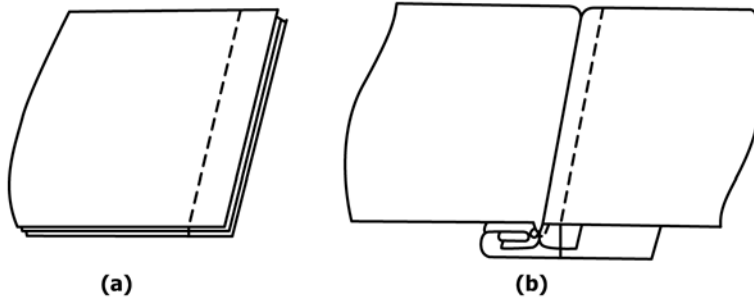

Seam type SSx-2

NOTE 1—This type of seam shall be formed by:

- (a) superimposing and seaming three plies of material as in seam type SSa-1 with a single row of stitches a specified distance from the edges, and
- (b) turning back the edges of the middle and bottom plies and the body of the bottom ply over these turned edges, turning back the edge of the top ply and the body of the top ply and seaming through the body and the turned edge of the top ply, and the body of the bottom ply with one row of stitches.

FIG. 90 Seam Type SSx

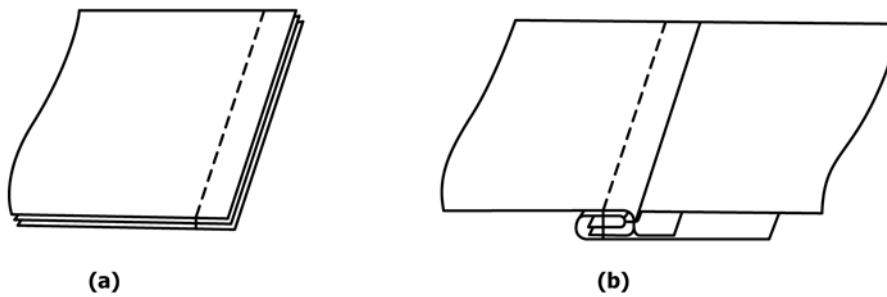

Seam type SSy-2

NOTE 1—This type of seam shall be formed by:

- (a) superimposing and seaming three plies of material in seam type SSa-1 with a single row of stitches a specified distance from the edge and
- (b) turning back the edges of the middle and bottom plies and the body of the bottom ply over these turned edges, turning back the edge of the top ply and the body of the top ply and seaming through the body of the middle ply, the turned edges of the middle and bottom ply and the body of the bottom ply.

FIG. 91 Seam Type SSy-2

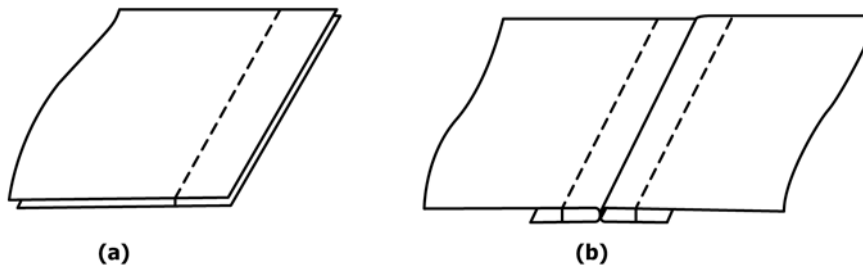

Seam type SSz-3

NOTE 1—This type of seam shall be formed by:

- (a) superimposing and seaming two plies of material in seam type SSa-1 and
- (b) opening the two plies and turning the edges of each ply back under the body of the ply and seaming through the turned edge of each ply with one row of stitches.

FIG. 92 Seam Type SSz-3

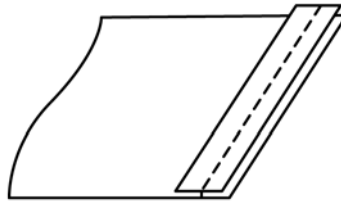

Seam type SSaa-1

NOTE 1—This type of seam shall be formed by superimposing a strip on one ply of material and seaming with one or more rows of stitches.

FIG. 93 Seam Type SSa-1

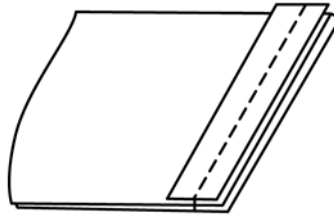

Seam type SSab-1

NOTE 1—This type of seam shall be formed by superimposing a strip on two plies of material and seaming with one or more rows of stitches.

FIG. 94 Seam Type SSab-1

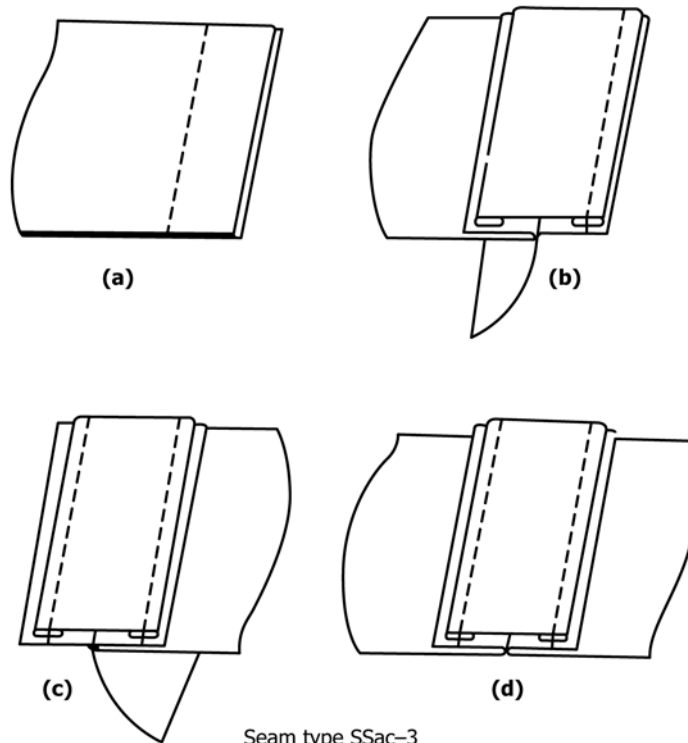

Seam type SSac-3

NOTE 1—This type of seam shall be formed by:

- (a) superimposing two plies of material and seaming with one row of stitches a specified distance from the edges in seam type SSa-1, and
- (b) turning one ply aside and seaming its edge to a strip with its edges turned in,
- (c) turning the other ply aside and seaming its edge to the strip, and
- (d) opening both plies of material to finish as shown.

FIG. 95 Seam Type ac-3

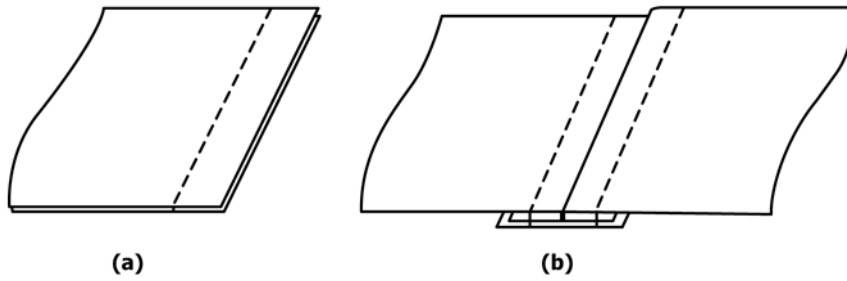

Seam type SSad-3

NOTE 1—This type of seam shall be formed by:
 (a) superimposing two plies of material and seaming with one row of stitches a specified distance from the edges in seam type SSa-1, and
 (b) opening the two plies, turning the edge of each ply under the body, superimposing to a reinforcing strip and seaming through the body, turned edge, and reinforcement strip.

FIG. 96 Seam Type ad-3

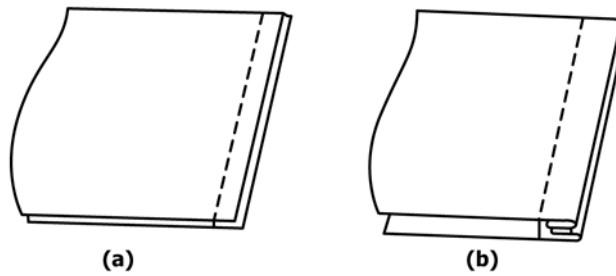

Seam type SSae-2

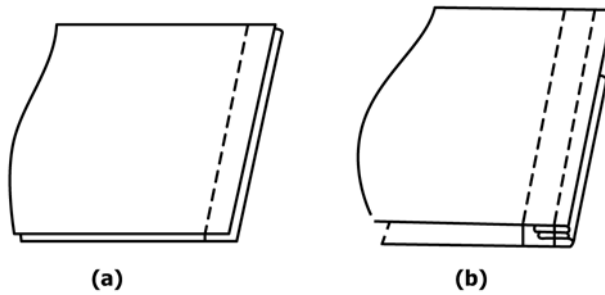

Seam type SSae-3

NOTE 1—This type of seam shall be formed by:
 (a) superimposing two plies of material and seaming with a row of stitches a specified distance from the edges in seam type SSa-1 and
 (b) turning both plies of material over their edges and seaming with one or more rows of stitches. When more than one row of stitches are used, one row shall pass through the folded edges.

FIG. 97 Seam Type SSae-3

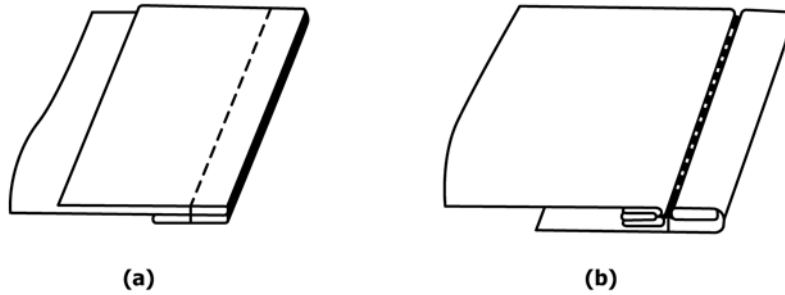

NOTE 1—This type of seam shall be formed by:
 (a) superimposing a welt strip on the body of a material which is superimposed on a stay piece and seaming with one row of stitches, and
 (b) opening the seam by turning the welt strip over on itself and under the body material and stay piece, the edges of which shall have been turned, and seaming through the first seam and welt strip.

FIG. 98 Seam Type SSaf-2

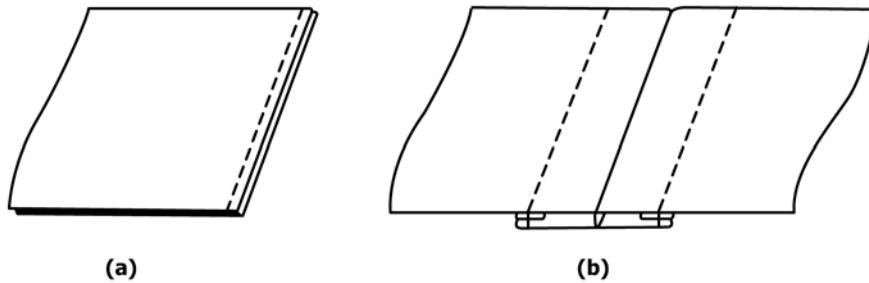

NOTE 1—This type of seam shall be formed:
 (a) superimposing two plies of material and seaming in seam type SSa-1, and
 (b) opening each ply and superimposing these over a reinforcing strip whose edges are turned in a specified distance, and seaming with two rows of stitches through the reinforcing strip.

FIG. 99 Seam Type SSag-3

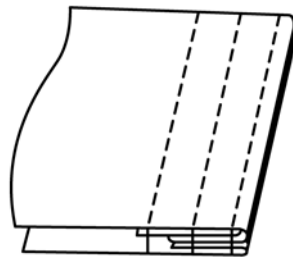

Seam type SSah-3

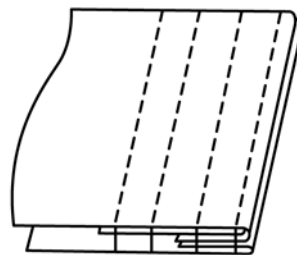

Seam type SSah-4

NOTE 1—This type of seam shall be formed by turning the edge of one ply of material around a tape and superimposing this on another ply with edge turned up and stitching with three or more rows of stitches, two rows of which shall be through the turned edges.

FIG. 100 Seam Type SSan

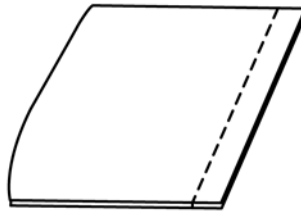

(a)

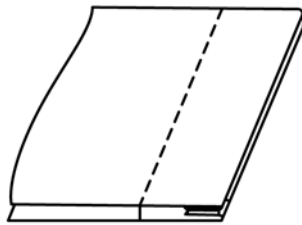

(b)

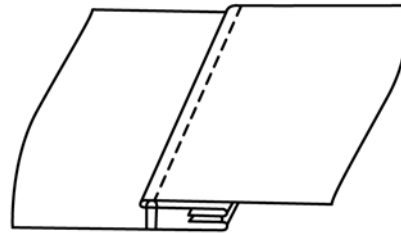

(c)

Seam type SSaj-3

NOTE 1—This type of seam shall be formed by:
 (a) superimposing two plies of material and seaming with a row of stitches a specified distance from the edge in seam type SSa-1,
 (b) turning both plies of material over their edges and seaming with one or more rows of stitches in seam type SSae-2, and
 (c) turning the top ply back over the seam and seaming with one row of stitches a specified distance from the second row of stitches.

FIG. 101 Seam Type SSaj-3

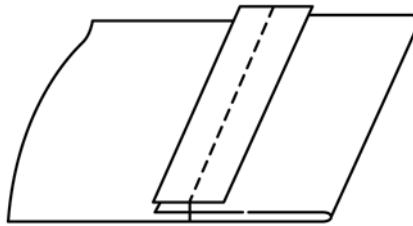

Seam type SSak-1

NOTE 1—This type of seam shall be formed by superimposing a strip on the fold of a body material a specified distance from the folded edge and seaming with one or more rows of stitches.

FIG. 102 Seam Type SSak-1

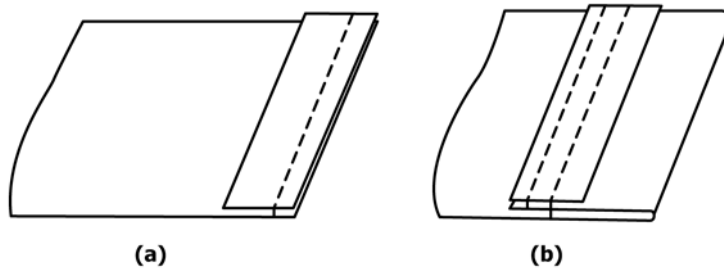

Seam type SSa1-2

NOTE 1—This type of seam shall be formed by:

- (a) superimposing a strip on one ply of material and seaming with one or more rows of stitches, and
- (b) folding the edge of the body ply and the strip over the body material and seaming through the strip and body material with one or more rows of stitches.

FIG. 103 Seam Type a1-2

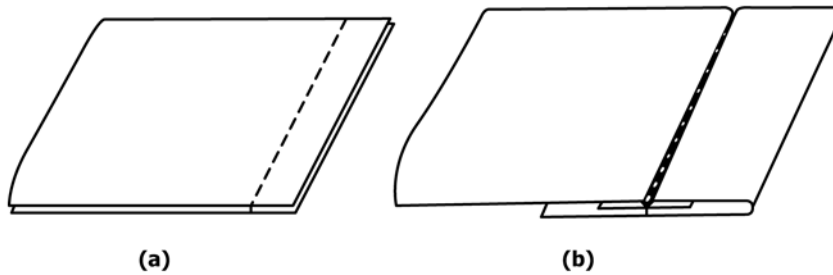

Seam type SSa2-2

NOTE 1—This type of seam shall be formed by:

- (a) superimposing and seaming two plies of material in seam type SSa-1, and
- (b) opening the two plies and turning the edges of each ply back under the body of the ply; turning the body ply back under these turned edges and seaming through the first seam with one row of stitches.

FIG. 104 Seam Type a2-2

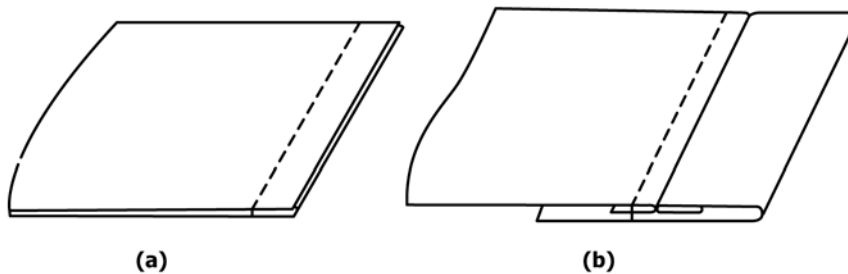

Seam type SSa3-2

NOTE 1—This type of seam shall be formed by:

- (a) superimposing and seaming two plies of material in seam type SSa-1, and
- (b) opening the two plies and turning the edges of each ply back under the body of the ply; turning the body of one ply over these turned edges and seaming through the body and turned edge of the top ply and the body of the bottom ply with one row of stitches.

NOTE 2—SSap is the same as SSa3 except (b) is further top-stitched through the body and turned edge of top ply with two row of stitches. Second row of stitches is to the right side of SSa-1 seam. No Seam Figure required.

FIG. 105 Seam Type SSa3-2

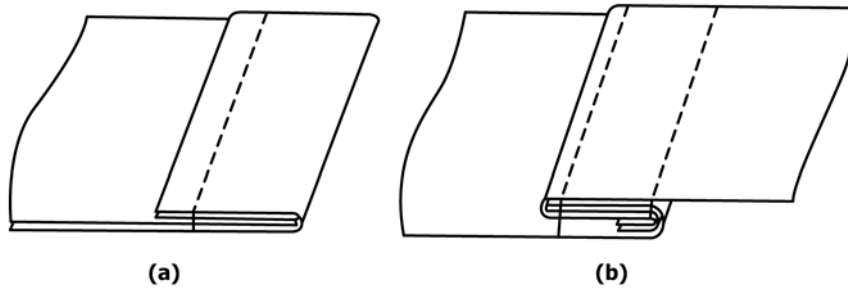

Seam type SSaq-2

NOTE 1—This type of seam shall be formed by:

- (a) superimposing two or more plies of material, folding both the edges back over the body of material a specified distance and seaming with one row of stitches, and
- (b) opening the plies of material, turning the seam to one side and seaming with one or more rows of stitches.

FIG. 106 Seam Type SSaq-2

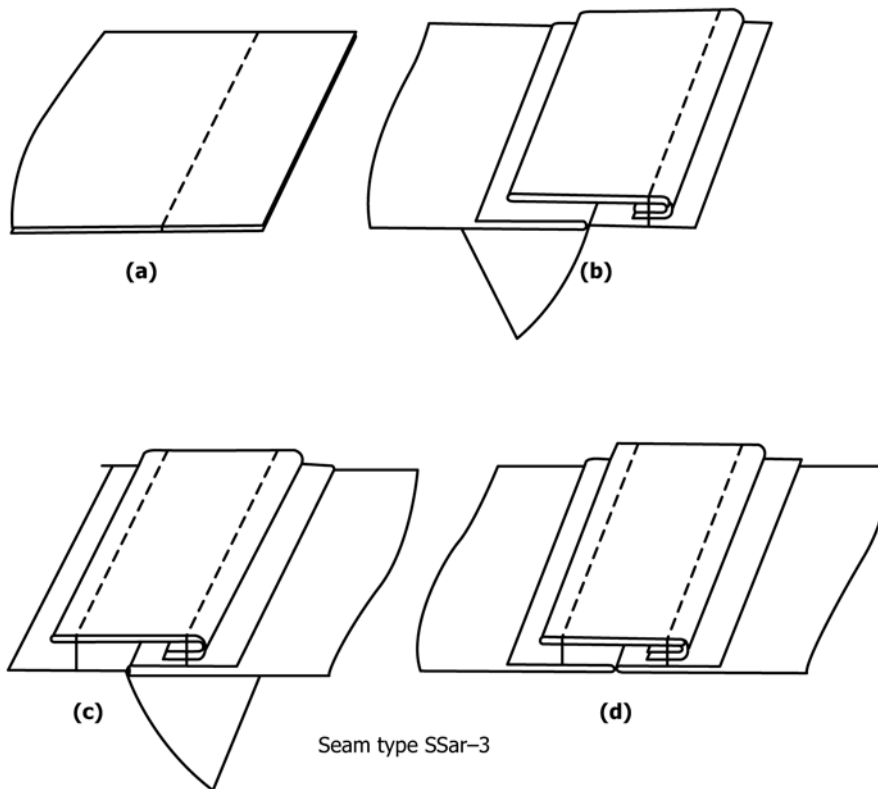

Seam type SSar-3

NOTE 1—This type of seam shall be formed by:

- (a) superimposing two plies of material and seaming with one row of stitches a specified distance from their edges in seam type SSa-1,
- (b) turning one ply aside and seaming its edge to a folded strip with its edges turned in,
- (c) turning the other ply aside and seaming its edge to the folded edge of the strip, and
- (d) opening both plies of material to finish as shown.

FIG. 107 Seam Type SSar-3

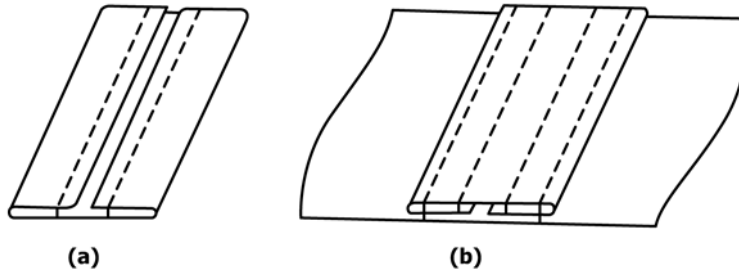

Seam type SSas-4

NOTE 1—This type of seam shall be formed by:
 (a) turning the edges of a strip of material and seaming with two rows of stitches, and
 (b) superimposing the stitched strip with the turned edges downward on a body material and seaming with two rows of stitches.

FIG. 108 Seam Type SSas-4

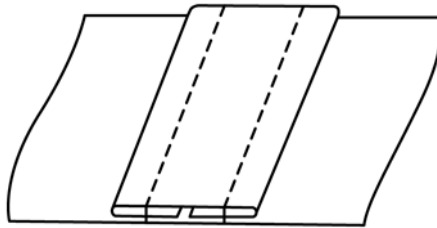

Seam type SSat-2

NOTE 1—This type of seam shall be formed by superimposing a strip with its edges turned under on a body material, and seaming the strip to the body material with two or more rows of stitches.

FIG. 109 Seam Type SSat-2

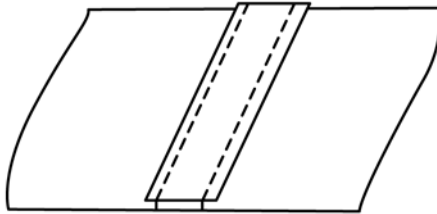

Seam type SSau-2

NOTE 1—This type of seam shall be formed by superimposing a strip on a body material and seaming with two or more rows of stitches.

FIG. 110 Seam Type SSau-2

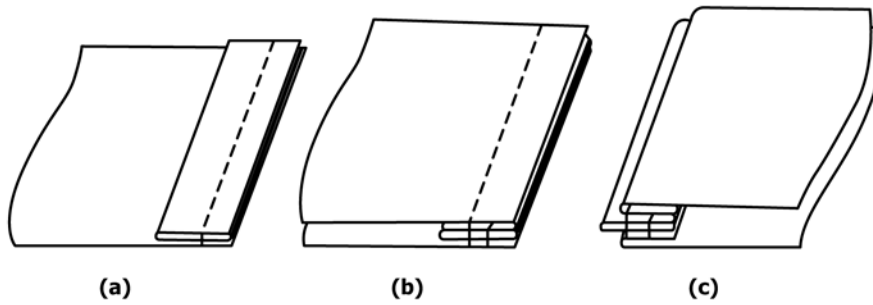

Seam type SSav-2

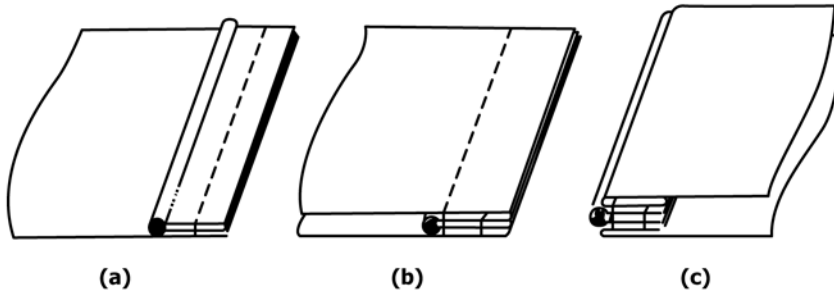

Seam type SSav-2
(with cord)

NOTE 1—This type of seam shall be formed by:
 (a) superimposing a folded strip of material, with or without a cord as specified, over a ply of material and seaming with one row of stitches, and
 (b) superimposing another ply of material and seaming with one row of stitches.

FIG. 111 Seam Type SSav-2

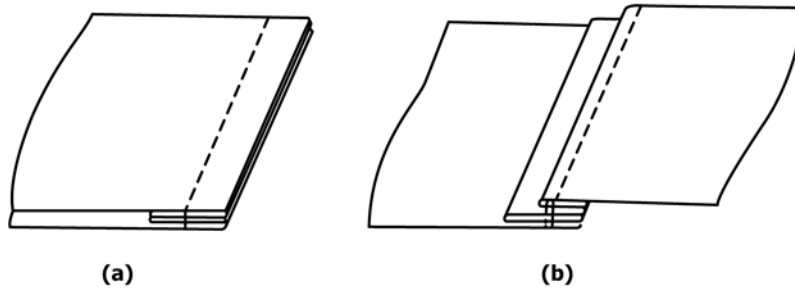

Seam type SSaw-2

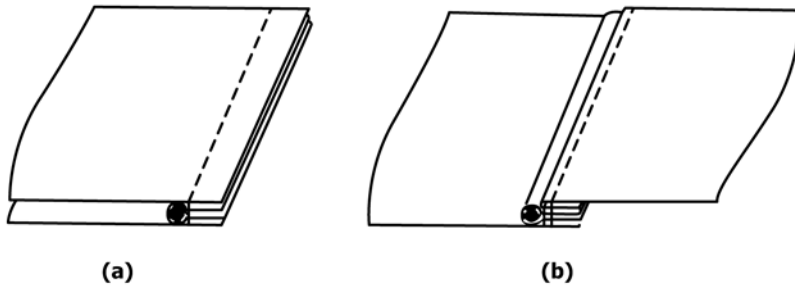

Seam type SSaw-2
(with cord)

NOTE 1—This type of seam shall be formed by:
 (a) inserting a folded strip of material, with or without a cord as specified, between two superimposed plies of material and seaming with one row of stitches, and
 (b) turning the top ply back sharply over the first row of stitches and seaming with one or more rows of stitches.

FIG. 112 Seam Type SSaw-2

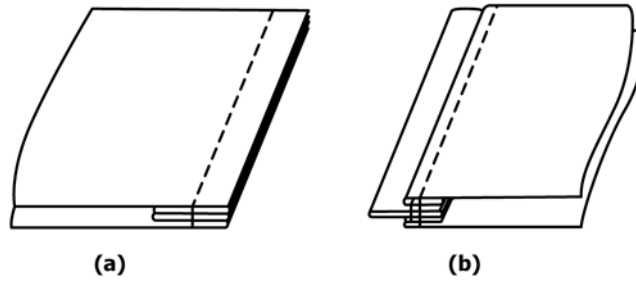

Seam type SSax-2

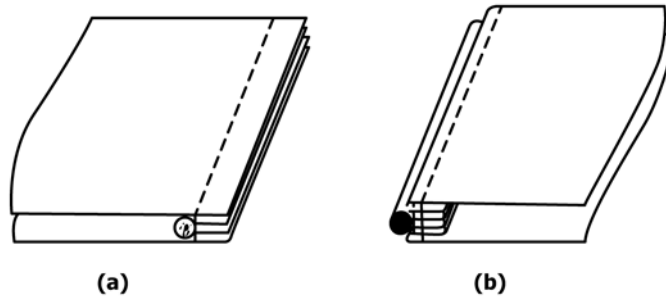

Seam type SSax-2
(with cord)

NOTE 1—This type of seam shall be formed by:

- (a) inserting a folded strip of material, with or without a cord as specified, between two superimposed plies of material and seaming with one row of stitches, and
- (b) turning both plies of material at the first seaming to cover the raw edges and seaming with one or more rows of stitches through the folded edges.

FIG. 113 Seam Type SSax-2

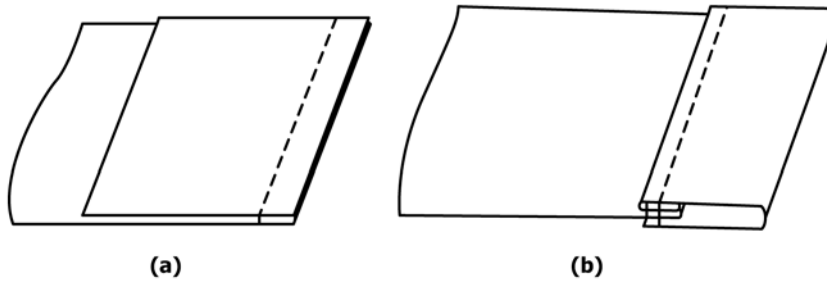

Seam type SSay-2

NOTE 1—This type of seam shall be formed by:

- (a) superimposing a strip on a ply of body material and seaming with one row of stitches in seam type SSa-1, and
- (b) turning the strip over the row of stitches, around the edge of the body material and seaming with a second row of stitches.

FIG. 114 Seam Type SSay-2

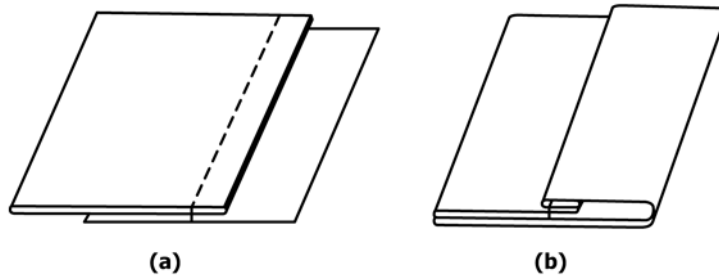

Seam type SSaz-1

NOTE 1—This type of seam shall be formed by:

- (a) folding a piece of body material with the face inside, placing the raw edges on a second ply, and seaming with one row of stitches a specified distance from the raw edge, and
- (b) turning the body material face out to envelop the second ply.

FIG. 115 Seam Type SSaz-1

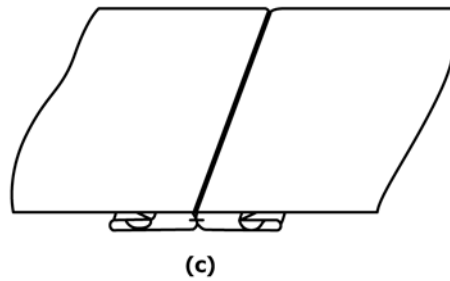
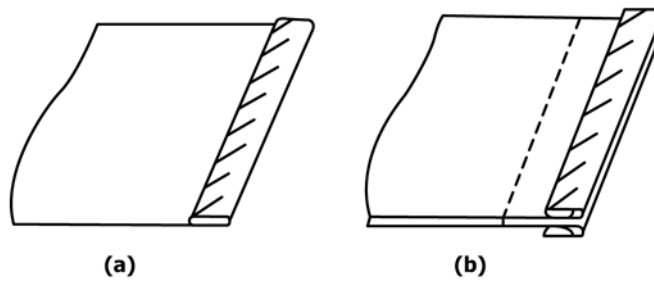

Seam type SSba-3

NOTE 1—This type of seam shall be formed by:

- (a) turning the edges of each of two plies of material and stitching the turned portion to the body of the material with one row of stitches,
- (b) superimposing the two plies and seaming a specified distance from the turned edges with one row of stitches, and
- (c) opening the two plies and turning the edge of each ply under the body to finish as shown.

FIG. 116 Seam Type SSba-3

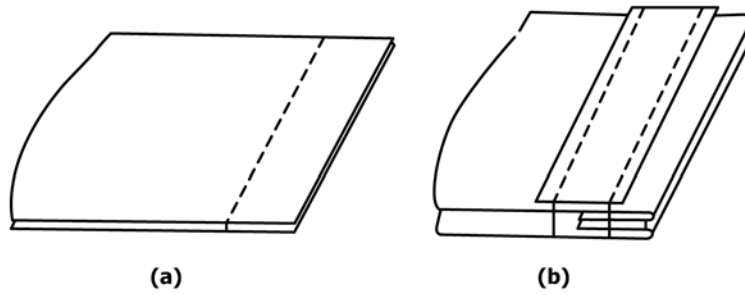

Seam type SSbb-3

NOTE 1—This type of seam shall be formed by:
 (a) superimposing two plies of material and seaming with a row of stitches a specified distance from the edges in seam type SSa-1, and
 (b) turning both plies of material over their edges, superimposing a strip and seaming with two or more rows of stitches.

FIG. 117 Seam Type SSbb-3

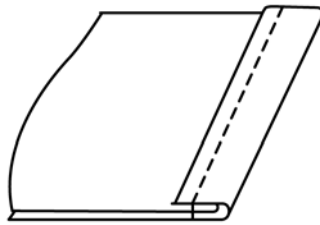

Seam type SSbc-1

NOTE 1—This type of seam shall be formed by superimposing two pieces of material, turning the edge of one ply of material over the edge of the second ply, and seaming with one or more rows of stitches.

FIG. 118 Seam Type SSbc-1

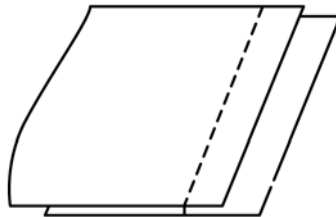

Seam type SSbd-1

NOTE 1—This type of seam shall be formed by superimposing two plies of material with their edges a specified distance apart and seaming with one or more rows of stitches a specified distance from the edge of the top ply.

FIG. 119 Seam Type SSbd-1

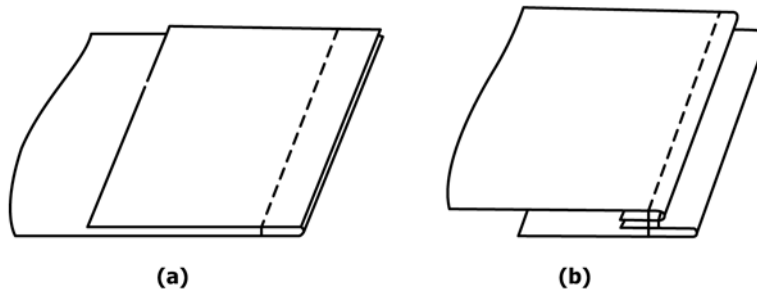

Seam type SSbe-2

NOTE 1—This type of seam shall be formed by:

- (a) superimposing two plies of material, or a strip on a body material, and seaming with one row of stitches a specified distance from the edges in seam type SSa-1, and
- (b) turning one of the plies at the first seaming and folding the other ply a specified distance from the first seaming, and seaming with a row of stitches through all plies.

FIG. 120 Seam Type SSbe-2

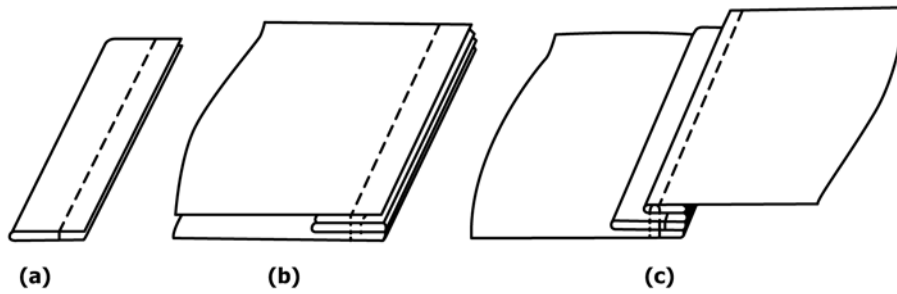

Seam type SSbf-3

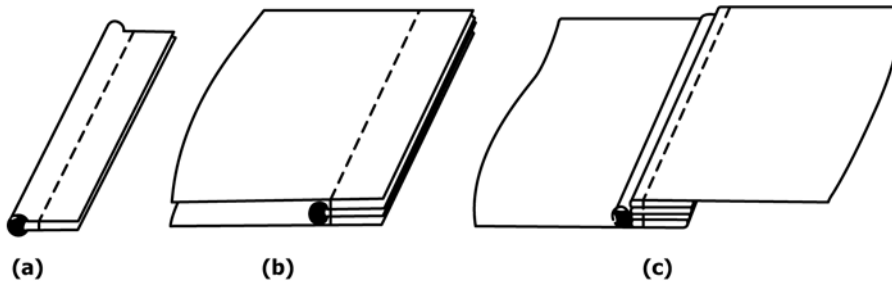

Seam type SSbf-3
(with cord)

NOTE 1—This type of seam shall be formed by:

- (a) folding a strip of material, with or without a cord as specified, and stitching a specified distance from the edge with one row of stitches,
- (b) inserting the folded and stitched strip of material between two superimposed plies of material and seaming with one row of stitches, and
- (c) turning the top ply back sharply over the first row of stitches and seaming with one or more rows of stitches.

FIG. 121 Seam Type SSbf-3

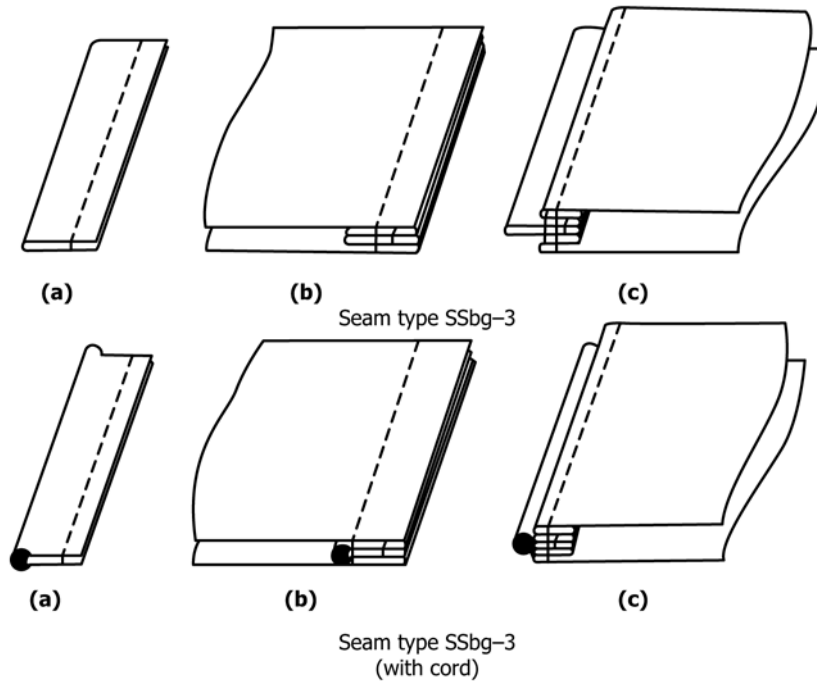

NOTE 1—This type of seam shall be formed by:
 (a) folding a strip of material, with or without a cord as specified, and stitching a specified distance from the edge with one row of stitches,
 (b) inserting the folded and stitched strip of material between two superimposed plies of material and seaming with one row of stitches, and
 (c) turning both plies of material at the seam to cover the raw edges and seaming with one or more rows of stitches through the folded edges.

FIG. 122 Seam Type SSbg-3

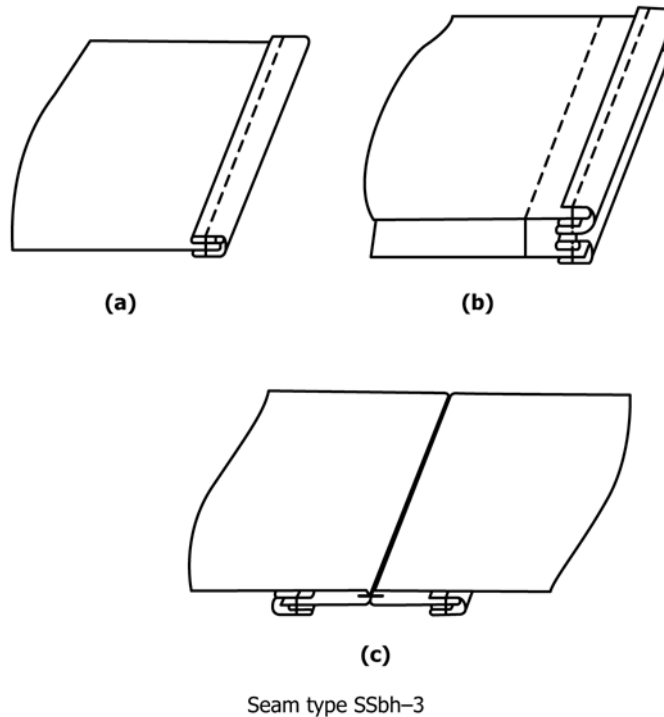

NOTE 1—This type of seam shall be formed by:
 (a) binding the edges of two plies of body material by turning one edge of a binding strip, folding it over the edge of the body material, and seaming the binding strip and body material with one row of stitches,
 (b) superimposing the two plies and seaming a specified distance from the bound edges with one row of stitches, and
 (c) opening the two plies and turning the bound edge of each ply under the body to finish as shown.

FIG. 123 Seam Type SSbh-3

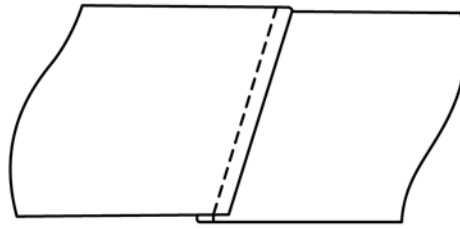

Seam type LSa-1

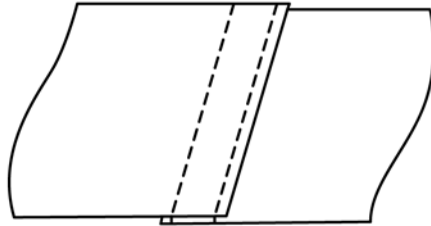

Seam type LSa-2

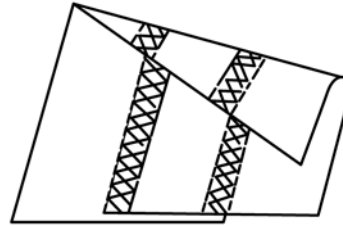

Seam type LSa-2

NOTE 1—This type of seam shall be formed by overlapping two or more plies of material a specified distance and seaming with one or more rows of stitches.

FIG. 124 Seam Type LSa

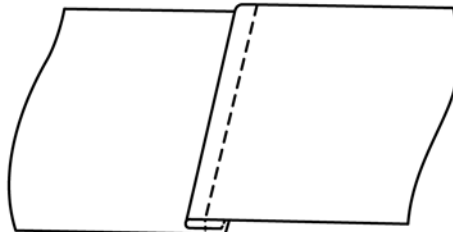

Seam type LSb-1

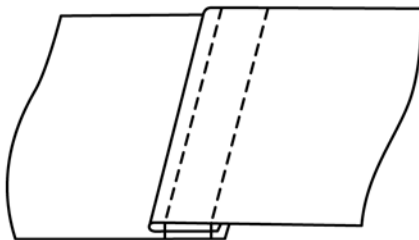

Seam type LSb-2

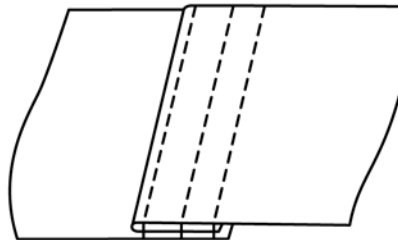

Seam type LSb-3

NOTE 1—This type of seam shall be formed by folding under the edge of one ply of the material overlapping it at the edge of another ply and seaming with one or more rows of stitches.

FIG. 125 Seam Type LSb

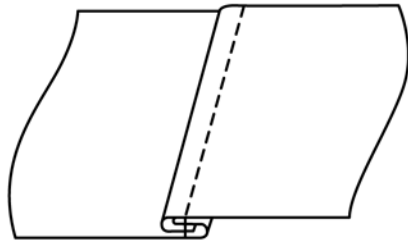

Seam type LSc-1

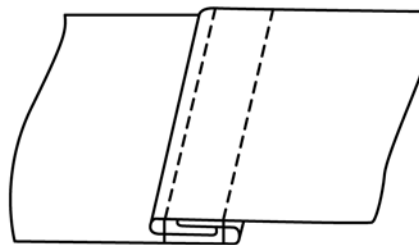

Seam type LSc-2

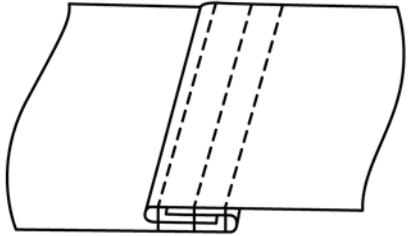

Seam type LSc-3

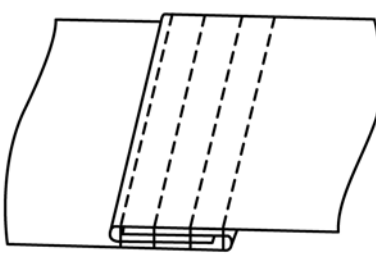

Seam type LSc-4

NOTE 1—This type of seam shall be formed by folding in and interlapping the edges of two plies of material so that the edges of the material are concealed and seaming with one or more rows of stitches.

FIG. 126 Seam Type LSc

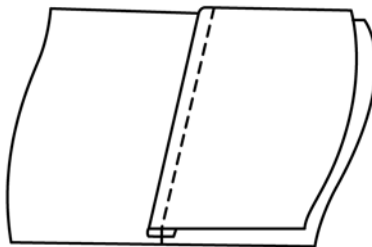

Seam type LSd-1

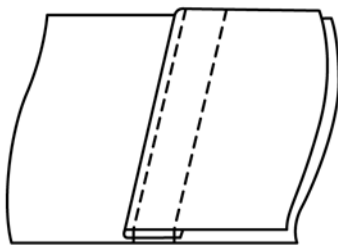

Seam type LSd-2

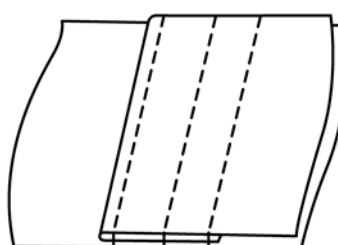

Seam type LSd-3

NOTE 1—This type of seam shall be formed by folding under the edge of one ply of material, lapping it on the body of another ply of material a specified distance from the edge, and seaming with one or more rows of stitches.

FIG. 127 Seam Type LSd

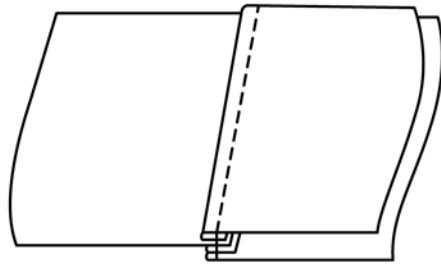

Seam type LSe-1

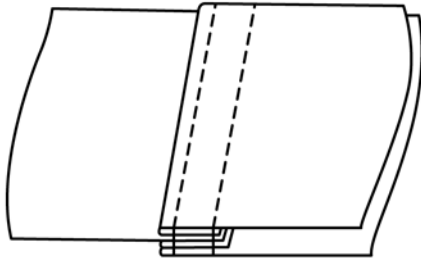

Seam type LSe-2

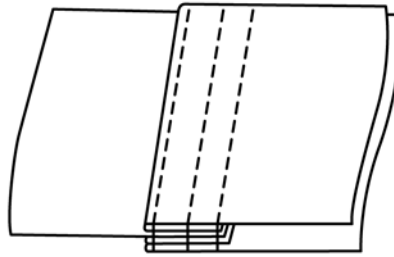

Seam type LSe-3

NOTE 1—This type of seam shall be formed by folding the edges of each of two plies of material, inserting a third ply of material between the folded edges and seaming all plies with one or more rows of stitches.

FIG. 128 Seam Type LSe

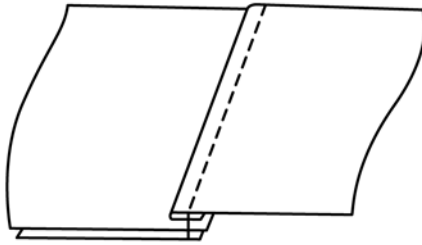

(a)

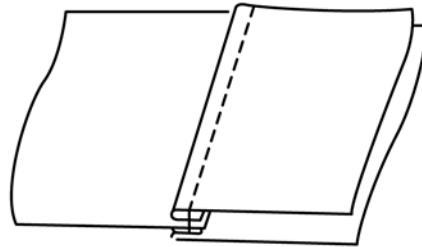

(b)

Seam type LSF-1

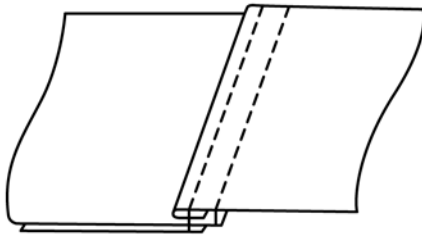

(a)

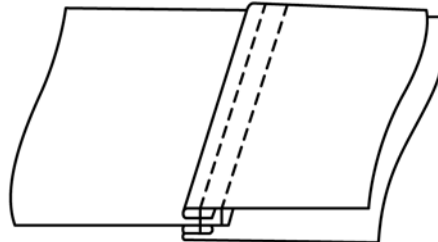

(b)

Seam type LSF-2

NOTE 1—This type of seam shall be formed by:

- (a) folding the edge of one ply of material, lapping it on two or more other plies and seaming with one or more rows of stitches. When more than one row of stitches are used, the inner ply shall be extended so that the second row of stitches does not go through the bottom ply, and
- (b) the bottom ply then shall be turned back to lie under the top ply (figure b).

FIG. 129 Seam Type LSF

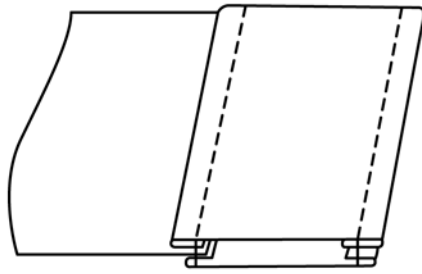

Seam type LSg-2

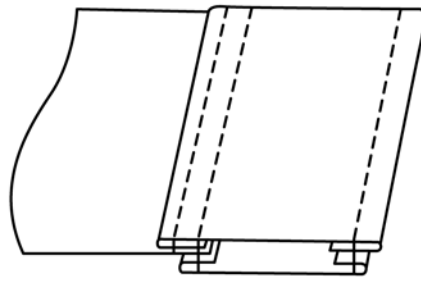

Seam type LSg-3

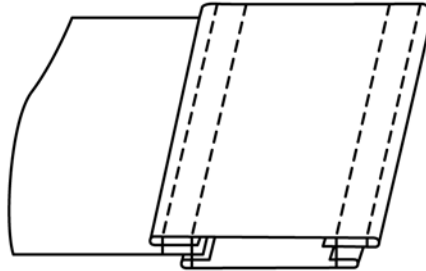

Seam type LSg-4

NOTE 1—This type of seam shall be formed by folding in both edges of two plies of material, inserting a third ply of material between the folded edges on one side and seaming each side with one or more rows of stitches.

FIG. 130 Seam Type LSg

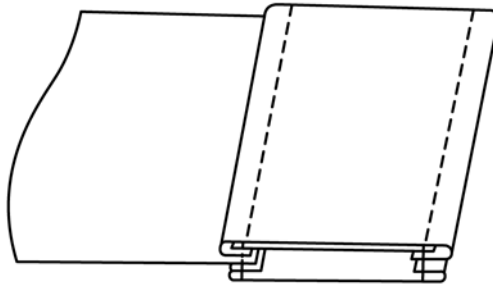

Seam type LSj-2

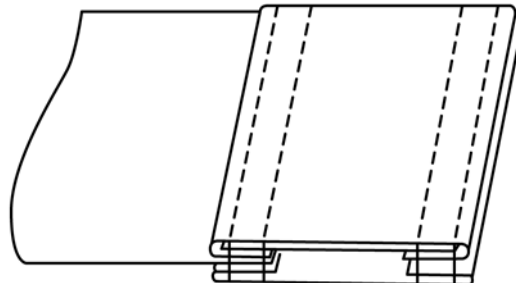

Seam type LSj-4

NOTE 1—This type of seam shall be formed by folding both edges of two plies of material, inserting a strip in the fold of the top ply, inserting the body material between the folded edges of both plies on one side and seaming with two or more rows of stitches.

FIG. 131 Seam Type LSj

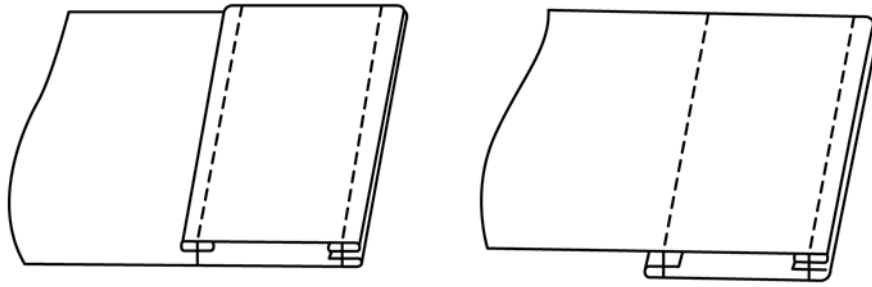

Seam type LSk-2

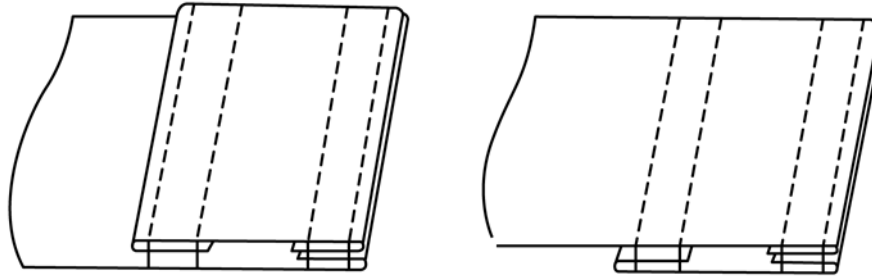

Seam type LSk-4

NOTE 1—This type of seam shall be formed by folding both edges of a strip of material and lapping it on the body material whose edge has been folded in, and seaming with two or more rows of stitches.

FIG. 132 Seam Type LSk

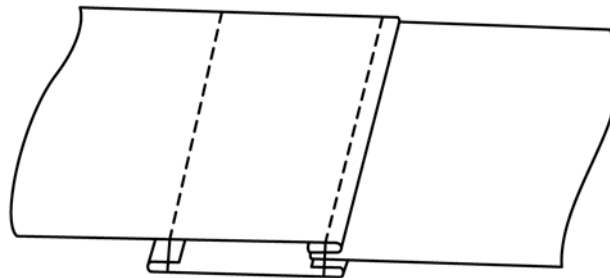

Seam type LSI-2

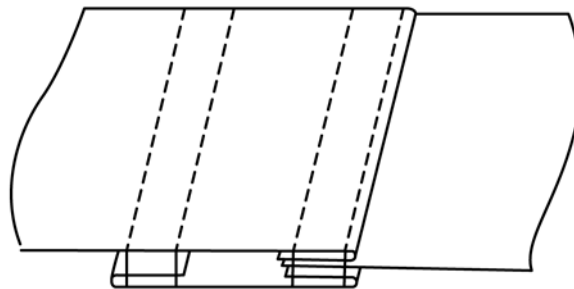

Seam type LSI-4

NOTE 1—This type of seam shall be formed by folding the edge of a body material, folding both edges of a strip of material, inserting one or more plies of material between the inturned edges of the body material and the strip, and seaming with two or more rows of stitches.

FIG. 133 Seam Type LSI

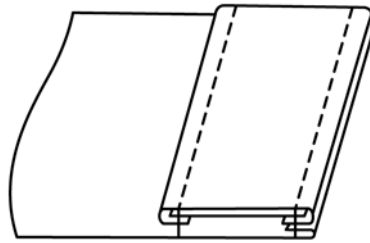

Seam type LSm-2

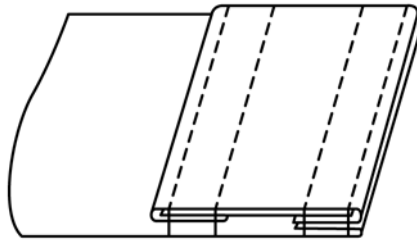

Seam type LSm-4

NOTE 1—This type of seam shall be formed by folding the edges of a ply of material over a strip, and lapping these two materials over a body material, whose edge has been folded in, and seaming with two or more rows of stitches.

FIG. 134 Seam Type LSm

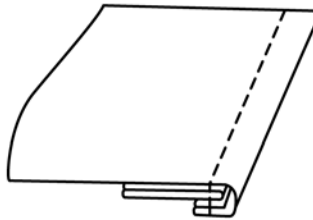

Seam type LSn-1

NOTE 1—This type of seam shall be formed by double folding the edge of a body material as for a hem (EFb) inserting a folded strip of material between the folded edge and the body of the body material and seaming with one or more rows of stitches.

FIG. 135 Seam Type LSn-1

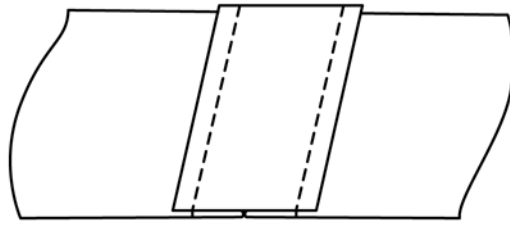

Seam type LSp-2

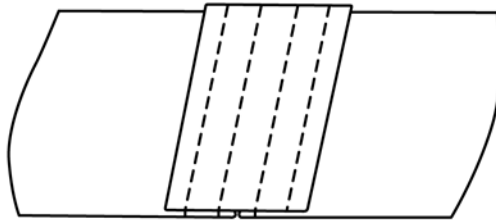

Seam type LSp-4

NOTE 1—This type of seam shall be formed by overlapping a strip of material over the abutted edges of two or more pieces of material and seaming with two or four rows of stitches.

FIG. 136 Seam Type LSp

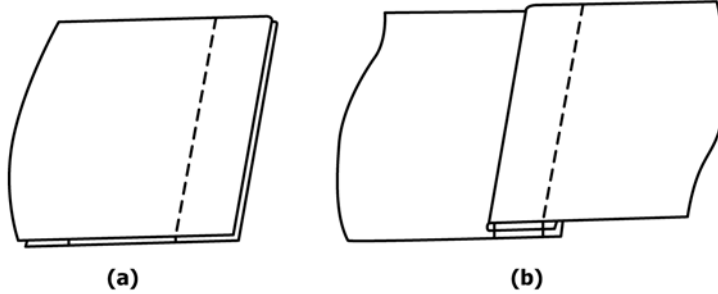

Seam type LSq-2

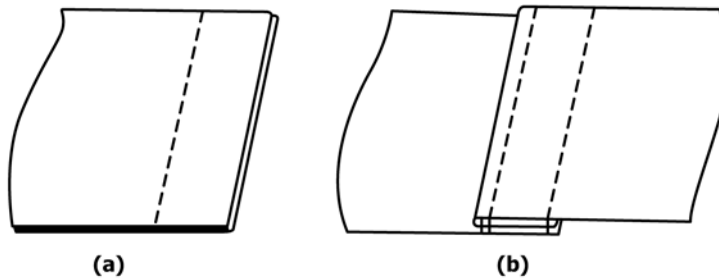

Seam type LSq-3

NOTE 1—This type of seam shall be formed by:
 (a) superimposing two plies of material and seaming as in seam type SSa-1, and
 (b) the top ply shall then be turned back sharply over the first row of stitching and seamed with one or more rows of stitches.

FIG. 137 Seam Type LSq

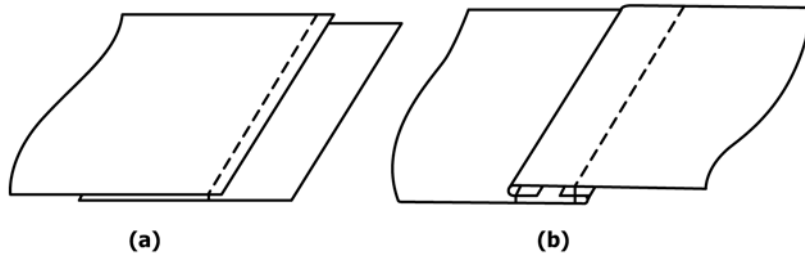

Seam type LSr-2

NOTE 1—This type of seam shall be formed by:

- (a) overlapping two plies of material with their edges a specified distance apart and seaming with one row of stitches a specified distance from the edge of the top ply, and
- (b) turning the top ply over the first row of stitching, folding in the edge of the bottom ply and seaming with a second row of stitches through top ply and turned edge of bottom ply.

FIG. 138 Seam Type LSr-2

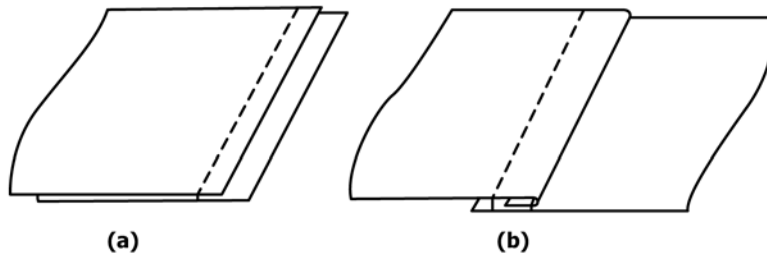

Seam type LSs-2

NOTE 1—This type of seam shall be formed by:

- (a) overlapping two plies of material with their edges a specified distance apart and seaming with one row of stitches a specified distance from the edge of the top ply, and
- (b) turning the top ply at the first seam and seaming with a second row of stitches through the bodies of top and bottom plies.

FIG. 139 Seam Type LSs-2

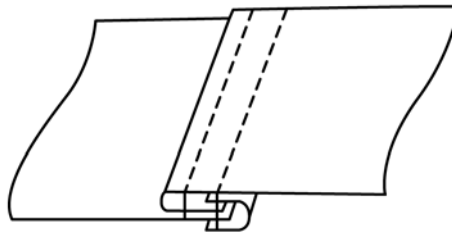

Seam type LSt-2

NOTE 1—This type of seam shall be formed by folding the edge of one ply of material and lapping it over a second ply, folding a binding strip over the edge of both plies, and seaming with two rows of stitches, only one of which shall secure the binding strip.

FIG. 140 Seam Type LST-2

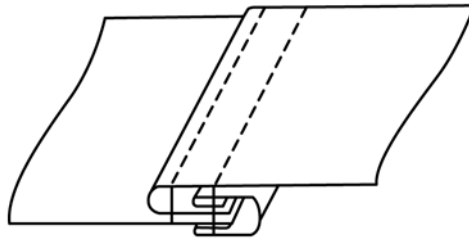

Seam type LSu-2

NOTE 1—This type of seam shall be formed by turning the edges of one ply of material and lapping it over a second ply, folding a binding strip with both edges folded in over the edge of both plies of material and seaming with two rows of stitches, only one of which shall secure the binding strip.

FIG. 141 Seam Type LSu-2

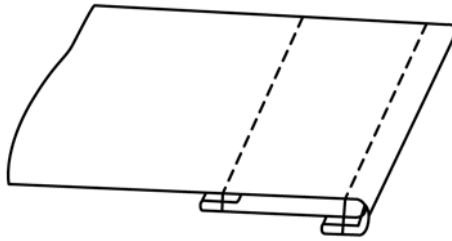

Seam type LSv-2

NOTE 1—This type of seam shall be formed by double folding the edge of the body material, lapping it over a strip of material so that one edge of the strip is between the body material and its folded edge, folding the opposite edge of the strip, and seaming the strip to the body of the material with two rows of stitches.

FIG. 142 Seam Type LSv-2

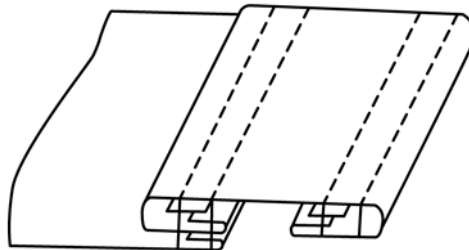

Seam type LSw-4

NOTE 1—This type of seam shall be formed by double folding each edge of a wide strip of material over a narrow strip, and lapping it over the folded edge of a body material and seaming with four rows of stitches.

FIG. 143 Seam Type LSw-4

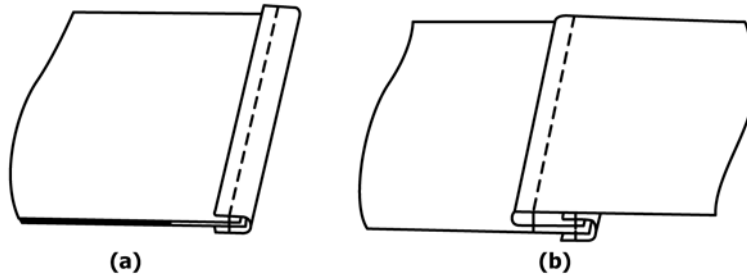

Seam type LSx-2

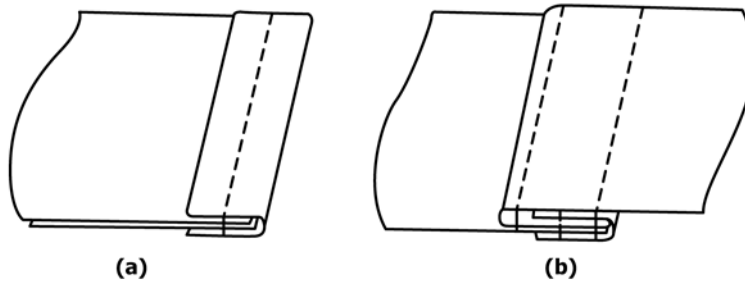

Seam type LSx-3

NOTE 1—This type of seam shall be formed by:
 (a) superimposing two plies of material, folding a binding strip over the edges of the plies, and seaming the plies and binding strip with one row of stitches, and
 (b) turning over the top ply a specified distance from the first row of stitches and seaming with one or more rows of stitches.

FIG. 144 Seam Type LSx

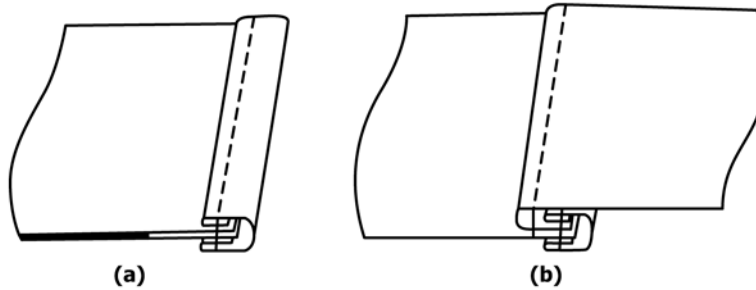

Seam type LSy-2

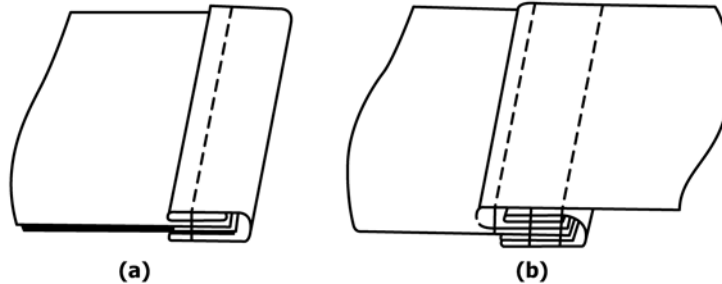

Seam type LSy-3

NOTE 1—This type of seam shall be formed by:
 (a) superimposing two plies of material, folding the edges of a binding strip, placing it over the edges of the material and seaming with one row of stitches, and
 (b) turning the top ply a specified distance from the first row of stitches and seaming with one or more rows of stitches.

FIG. 145 Seam Type LSy

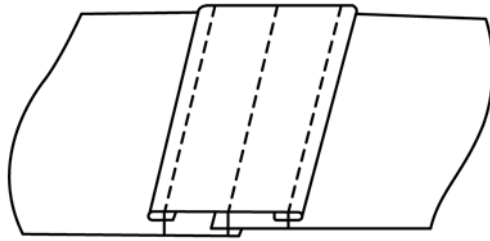

Seam type LSz-3

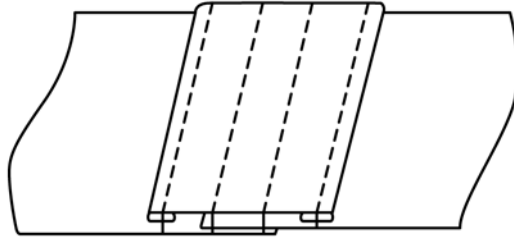

Seam type LSz-4

NOTE 1—This type of seam shall be formed by overlapping the edges of two or more plies of material, lapping a strip of material with the edges folded in over the overlapped edges and seaming with three or more rows of stitches.

FIG. 146 Seam Type LSz

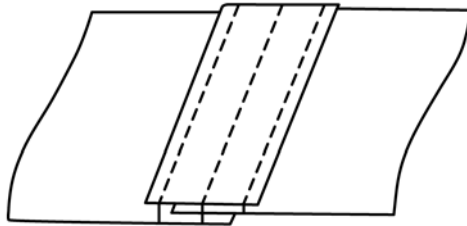

Seam type LSaa-3

NOTE 1—This type of seam shall be formed by overlapping the edges of two or more plies of material, superimposing a strip of material over the overlapping edges and seaming with three or more rows of stitches.

FIG. 147 Seam Type LSaa-3

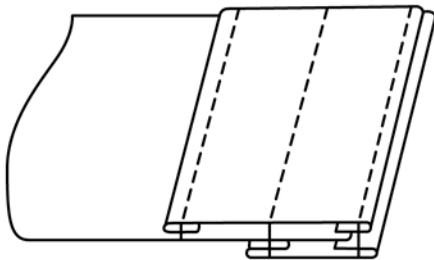

Seam type LSab-3

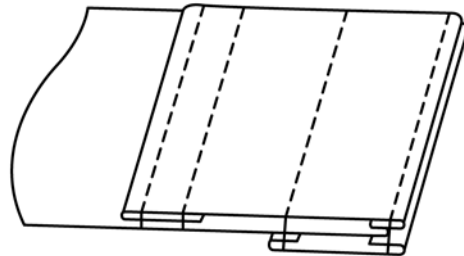

Seam type LSab-4

NOTE 1—This type of seam shall be formed by folding the edges of a strip of material, lapping it on a second ply and lapping both of these over a third ply substantially different in width with its edges folded, and seaming with three or more rows of stitches as follows: One row shall join the strips on the outer edges; a second row of stitches shall join the top strip, the middle ply and the bottom ply through the turned edge, and the remaining row or rows shall join the top strip to the middle ply.

FIG. 148 Seam Type LSab

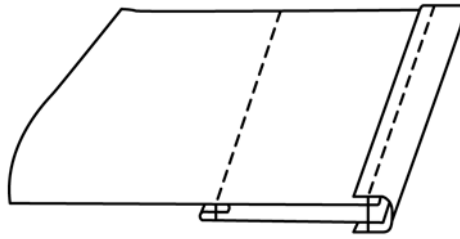

Seam type LSac-2

NOTE 1—This type of seam shall be formed by lapping a ply of body material over a narrow strip, one edge of which shall be folded in under the top ply, placing a binding strip over the other edges of the strip and body material and seaming with two or more rows of stitches.

FIG. 149 Seam Type LSac-2

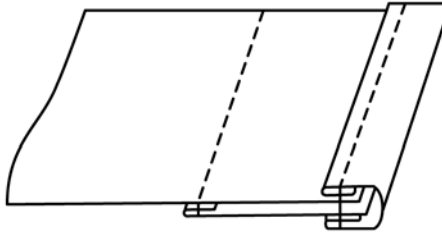

Seam type LSad-2

NOTE 1—This type of seam shall be formed by lapping a ply of body material over a narrow strip, one edge of which is folded in under the body of the first ply, placing a binding strip with both edges folded in over the other edges of the strip and body material and seaming with two or more rows of stitches.

FIG. 150 Seam Type LSad-2

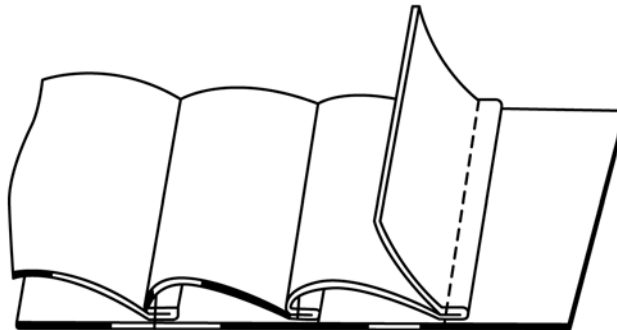

Seam type LSae-1

NOTE 1—This type of seam shall be formed by lapping one ply of material on to a second ply, folding the top ply back and seaming through the folded portion to the second ply with one or more rows of stitches. Note: the drawing illustrates the basic seam and two repeats.

FIG. 151 Seam Type LSae-1

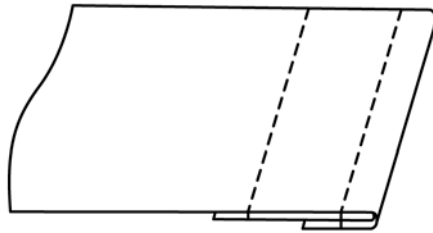

Seam type LSaf-2

NOTE 1—This type of seam shall be formed by lapping one ply of material over a second ply, turning the edge of the first ply around the edge of the second ply and seaming with two or more rows of stitches.

FIG. 152 Seam Type LSaf-2

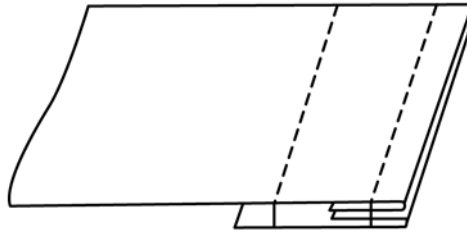

Seam type LSag-2

NOTE 1—This type of seam shall be formed by lapping one ply of material over a second ply, folding one edge of each ply to the inside, and seaming with two or more rows of stitches.

FIG. 153 Seam Type LSag-2

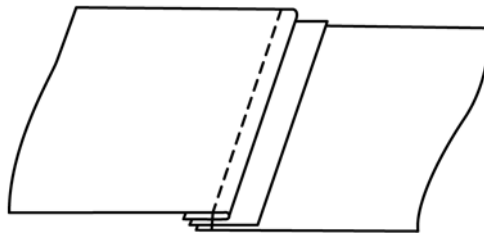

Seam type LSah-1

NOTE 1—This type of seam shall be formed by lapping the folded edge of one ply of material over a second ply, inserting a strip between and seaming all plies with one or more rows of stitches.

FIG. 154 Seam Type LSah-1

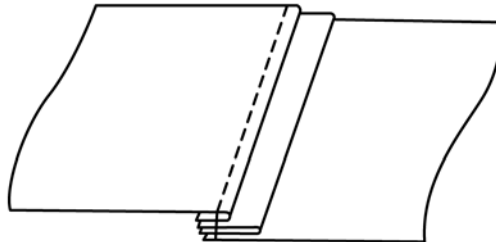

Seam type LSaj-1

NOTE 1—This type of seam shall be formed by lapping the folded edge of one ply of material over a second ply, inserting a folded strip between the two plies, and seaming all plies with one or more rows of stitches.

FIG. 155 Seam Type LSaj-1

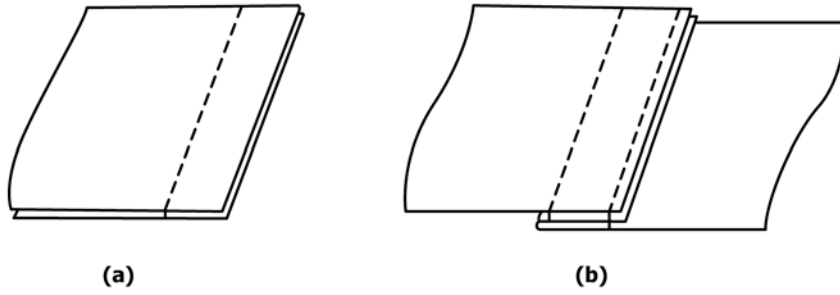

NOTE 1—This type of seam shall be formed by:
 (a) superimposing two plies of material and seaming with one row of stitches, seam type SSa-1, and
 (b) turning the bottom ply over the first row of stitches and seaming with one or more rows of stitches.

FIG. 156 Seam Type LSa-2

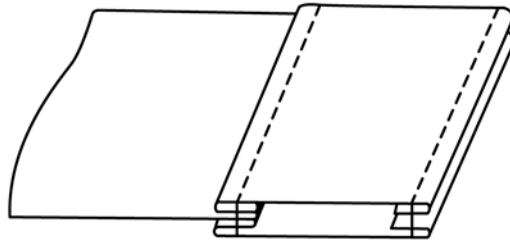

Seam type LSa-2

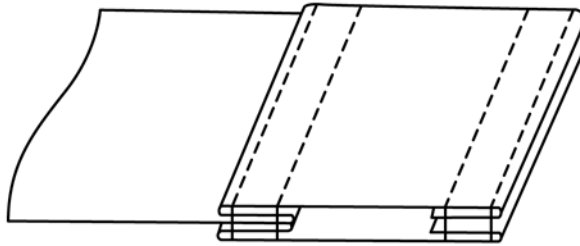

Seam type LSa-4

NOTE 1—This type of seam shall be formed by folding one ply of material into an “S” fold at a specified distance from the edge, folding in the edge and lapping it over a strip of material with the edges folded in and seaming with two or more rows of stitches.

FIG. 157 Seam Type LSa1

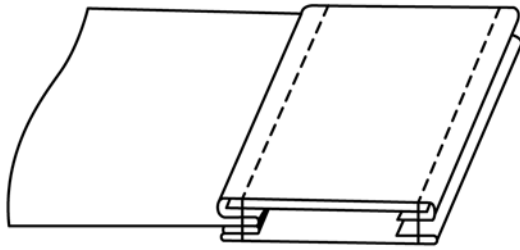

Seam type LSam-2

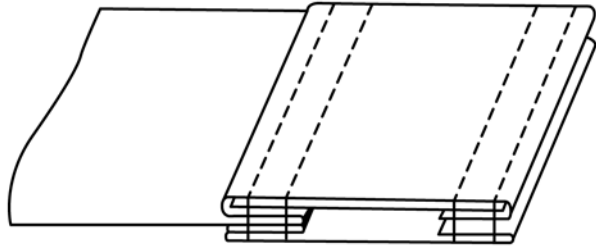

Seam type LSam-4

NOTE 1—This type of seam shall be formed by folding one ply of material into an “S” fold, folding in the outer edge, inserting an interlining strip in the folds, and lapping these over another ply whose edges shall be folded in, and seaming with two or more rows of stitches.

FIG. 158 Seam Type LSam

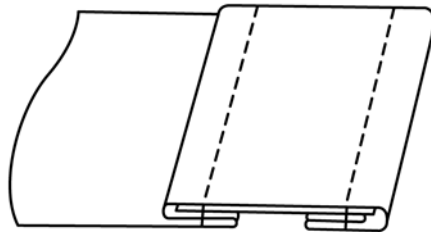

Seam type LSan-2

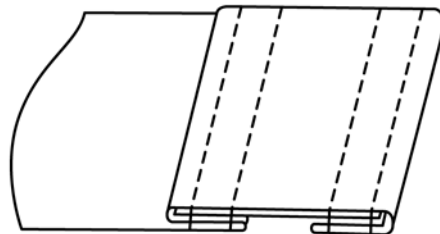

Seam type LSan-4

NOTE 1—This type of seam shall be formed by folding one ply of material into an “S” fold, turning in and folding over the outer edge, inserting an interlining strip, and seaming with two rows of stitches.

FIG. 159 Seam Type LSan

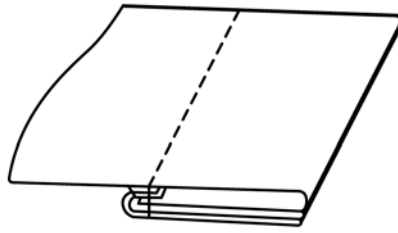

Seam type LSap-1

NOTE 1—This type of seam shall be formed by folding one ply of material over on itself, lapping it on another folded ply, folding the edges of the bottom ply over the folded edge of the top ply and seaming with one or more rows of stitches through all plies of material at the folded in edges.

FIG. 160 Seam Type LSap-1

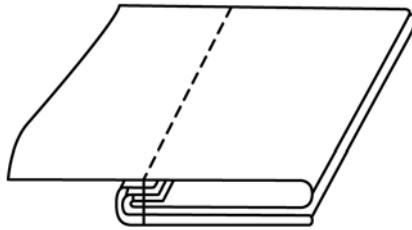

Seam type LSaq-1

NOTE 1—This type of seam shall be formed by folding one ply of material over on itself, folding the edge in, lapping it on another folded ply whose edge shall be folded in between the body of the first ply and its folded edge, and seaming with one or more rows of stitches through all plies at the folded in edges.

FIG. 161 Seam Type LSaq-1

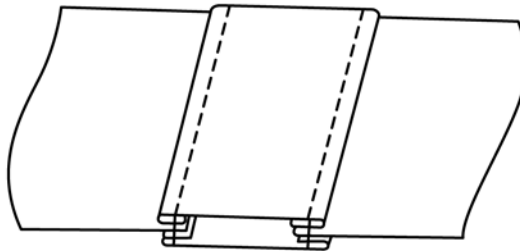

Seam type LSar-2

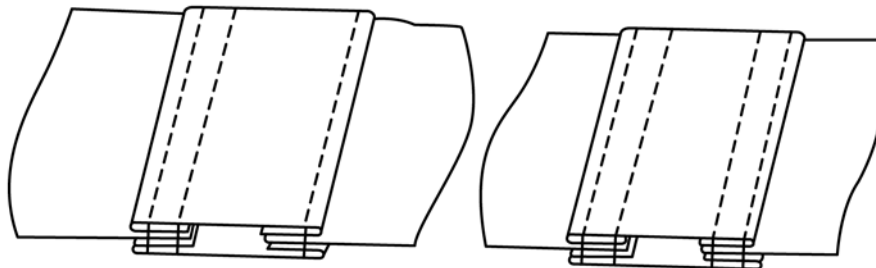

Seam type LSar-3

Seam type LSar-4

NOTE 1—This type of seam shall be formed by folding the edges of two strips of material, lapping one on the other, inserting two or more pieces of material between them at the folded edges, and seaming with two or more rows of stitches through the folded edges and inserted material.

FIG. 162 LSar

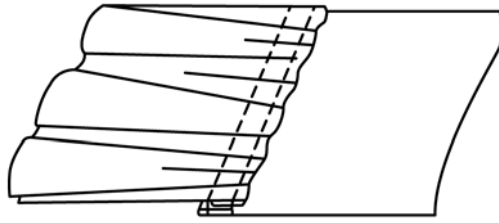

Seam type LSas-2

NOTE 1—This type of seam shall be formed by folding the edges of two plies of material, lapping the folded edges over each other, and seaming with two or more rows of stitches.

FIG. 163 Seam Type LSas-2

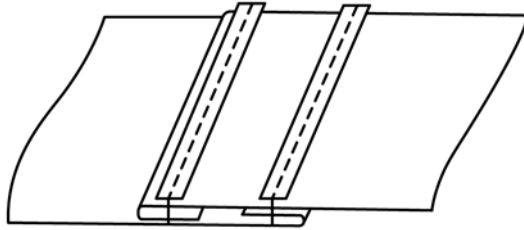

Seam type LSat-2

NOTE 1—This type of seam shall be formed by lapping two plies of material with edges folded in, placing a strip of material on the top ply over each turned edge, and seaming with one row of stitches through each strip and all three plies of material.

FIG. 164 Seam Type LSat-2

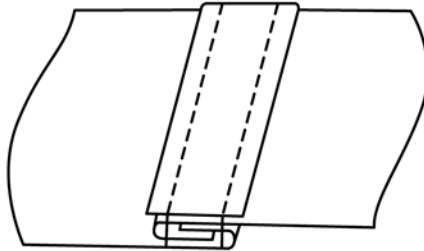

Seam type LSau-2

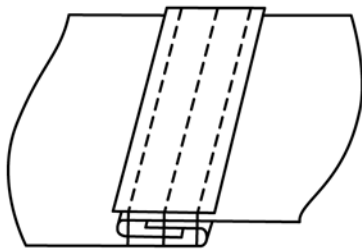

Seam type LSau-3

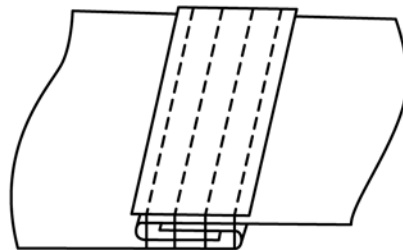

Seam type LSau-4

NOTE 1—This type of seam shall be formed by folding and interlapping the edges of two plies of material so that their edges are concealed, placing a strip of material on the top ply over the folded edges and seaming with two or more rows of stitches.

FIG. 165 Seam Type LSau

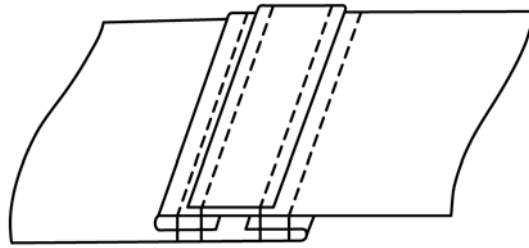

Seam type LSav-4

NOTE 1—This type of seam shall be formed by lapping two plies of material, folding in the edges of both plies, placing a strip on the top ply, and stitching with four rows of stitches, two rows through the strip and the remaining two through the folded edges of the material.

FIG. 166 Seam Type LSav-4

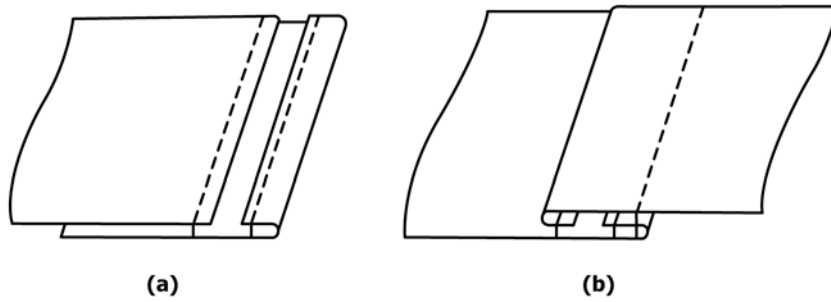

Seam type LSaw-3

NOTE 1—This type of seam shall be formed by:

- (a) lapping one ply of material over another a specified distance from the edge, folding the edge of the bottom ply and seaming with two rows of stitches, one through the edge of the top ply and body of the second ply and one through the folded edge of the bottom ply, and
- (b) turning the top ply over at the row of stitches and seaming with one row of stitches through the body of the top ply and turned edge of the bottom ply.

FIG. 167 Seam Type LSaw-3

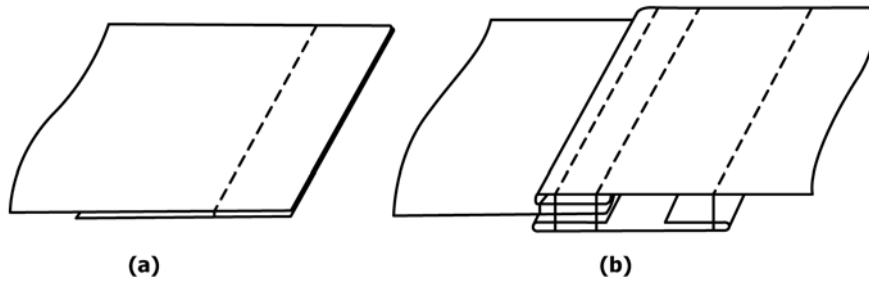

Seam type LSax-4

NOTE 1—This type of seam shall be formed by:

- (a) superimposing two plies of material and seaming with one row of stitches a specified distance from the edge in seam type SSa-1, and
- (b) turning the top ply at the first row of stitches, superimposing on a third ply with edges folded and seaming with three rows of stitches.

FIG. 168 Seam Type LSax-4

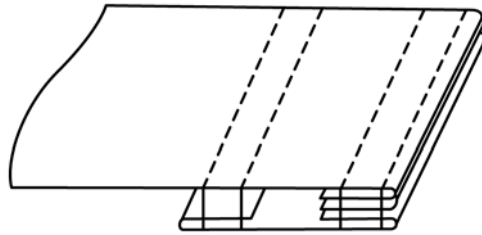

Seam type LSay-4

NOTE 1—This type of seam shall be formed by folding the edges of a strip of material and lapping it on the body material whose edge has been folded in, inserting a strip between the folded edges of the body material and the strip, and seaming with four rows of stitches.

FIG. 169 Seam Type LSay-4

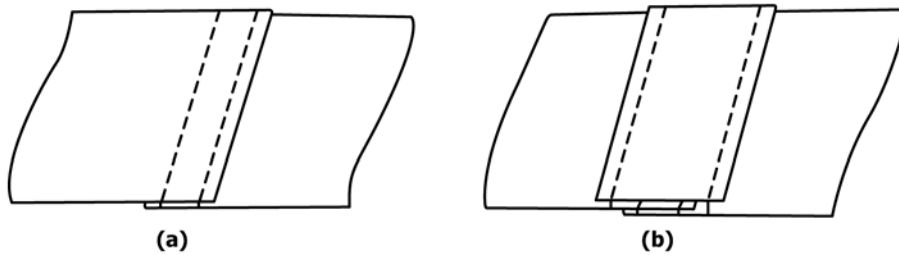

Seam type LSaz-4

NOTE 1—This type of seam shall be formed by:
 (a) overlapping two plies of material and seaming with two rows of stitches in seam type LSa-2, and
 (b) placing a strip or tape over the first seam and seaming with two rows of stitches beyond each of the overlapped edges of the material.

FIG. 170 Seam Type LSaz-4

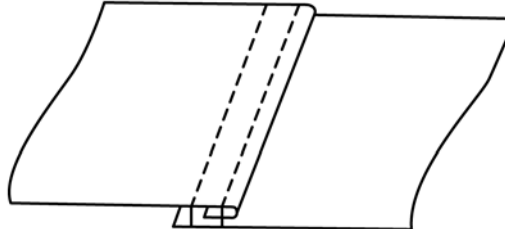

Seam type LSba-2

NOTE 1—This type of seam shall be formed by folding the edge of a ply of material and lapping it on another ply, and seaming with two rows of stitches. Only one row of the stitches shall pass through the turned under edge.

FIG. 171 Seam Type LSba-2

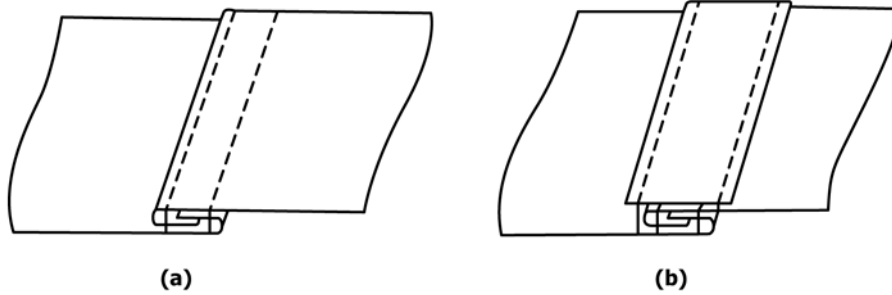

Seam type LSbb-4

NOTE 1—This type of seam shall be formed by:
 (a) lapping to plies of material, folding both edges in and seaming with two rows of stitches as in seam type LSc-2, and
 (b) placing a strip or tape over the first seam and seaming it to the body material with a row of stitches on each side of the seam.

FIG. 172 Seam Type LSbb-4

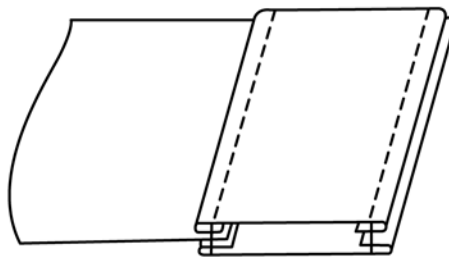

Seam type LSbc-2

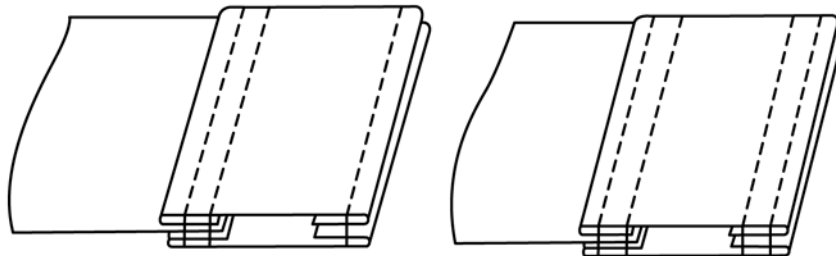

Seam type LSbc-3

Seam type LSbc-4

NOTE 1—This type of seam shall be formed by folding in both edges of two plies of material, lapping one on the other, inserting a third ply of material between them and seaming with two or more rows of stitches.

FIG. 173 Seam Type LSbc

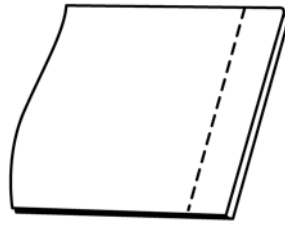

(a)

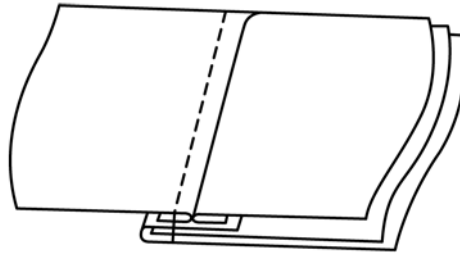

(b)

Seam type LSbd-2

NOTE 1—This type of seam shall be formed by superimposing two plies of material and seaming with one row of stitches in seam type SSa-1; opening the two plies, and turning the edges of each ply back under the body of the ply; overlapping the seam onto two plies of material, the edge of one ply which has been turned up over the edge of the other ply, and seaming through all plies with one row of stitches on the side of the seam nearest the folded edge of the bottom ply.

FIG. 174 Seam Type LSbd-2

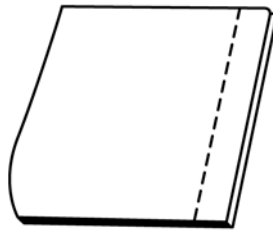

(a)

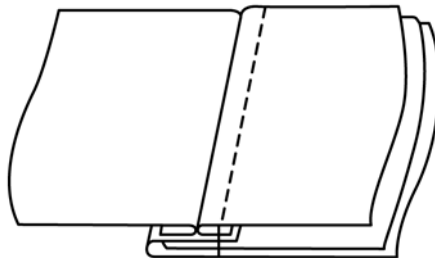

(b)

Seam type LSbe-2

NOTE 1—This type of seam shall be formed by superimposing two plies of material and seaming with one row of stitches in seam type SSa-1; opening the two plies and turning the edges of each ply back under the body of the ply; overlapping the seam onto two plies of material, the edge of one ply which has been turned up over the other ply, and seaming through all plies with one row of stitches on the side of the seam furthest from the folded edge of the bottom ply.

FIG. 175 Seam Type LSbe-2

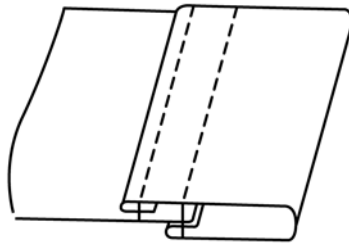

Seam type LSbf-2

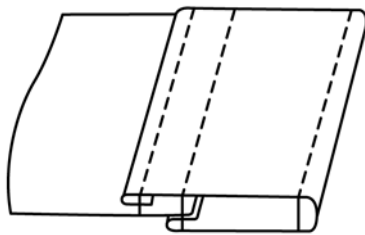

Seam type LSbf-3

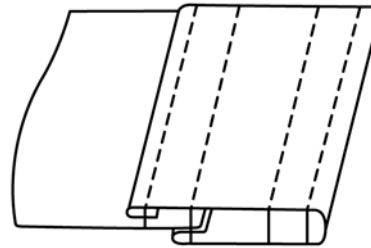

Seam type LSbf-4

NOTE 1—This type of seam shall be formed by turning both edges of a strip, folding it over the edge of a ply of material, the lower ply not extending as deep as the upper ply and seaming with two or more rows of stitches.

FIG. 176 Seam Type LSbf

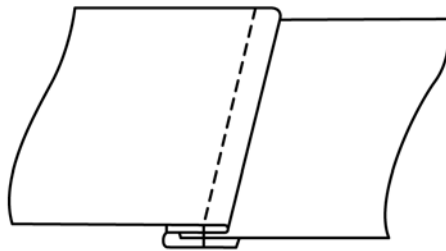

(a)

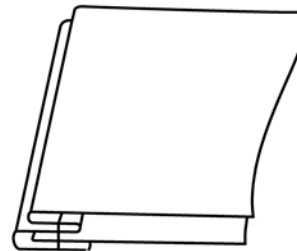

(b)

Seam type LSbg-1

NOTE 1—This type of seam shall be formed by:

- (a) turning the edge of one ply of material in a reverse “S” fold, inserting a second ply in the fold nearer the edge, seaming with one row of stitches, and
- (b) turning the upper ply back to form the finished seam.

FIG. 177 Seam Type LSbg-1

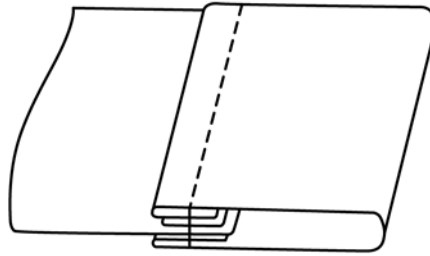

Seam type LSbh-1

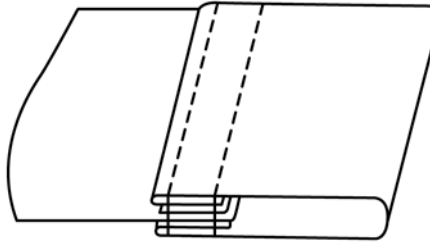

Seam type LSbh-2

NOTE 1—This type of seam shall be formed by turning both edges of a strip and folding it over the ply or plies of body material. A tape shall be inserted between one folded edge of the binding strip and the body material and seamed with one or more rows of stitches.

FIG. 178 Seam Type LSbh

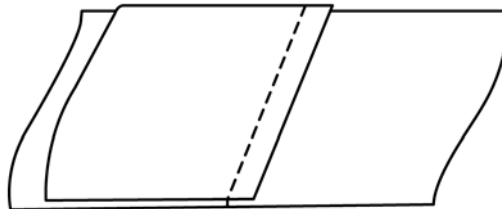

Seam type LSbj-1

NOTE 1—This type of seam shall be formed by lapping a ply of material on a body material and seaming with one or more rows of stitches.

FIG. 179 Seam Type LSbj-1

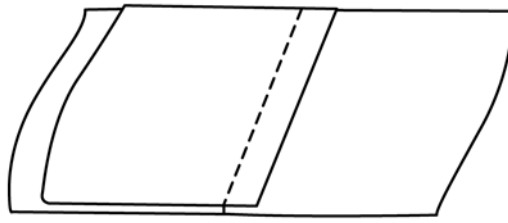

(a)

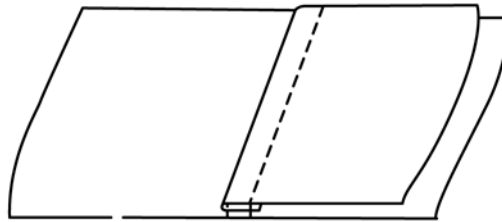

(b)

Seam type LSbk-2

NOTE 1—This type of seam shall be formed by:

- (a) lapping a ply of material on a body material and seaming with one row of stitches, and
- (b) turning the top ply back sharply over the first row of stitches and seaming with one or more rows of stitches.

FIG. 180 Seam Type LSbk-2

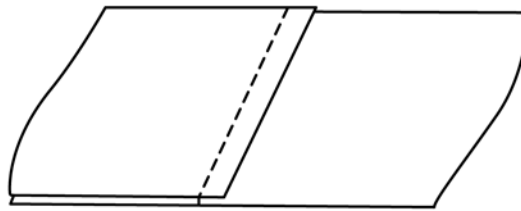

(a)

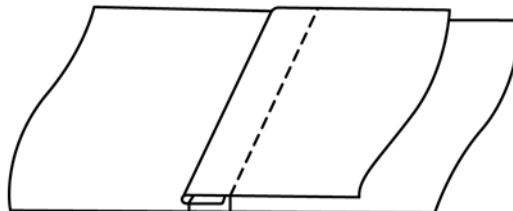

(b)

Seam type LSbl-2

NOTE 1—This type of seam shall be formed by:

- (a) lapping a ply of material on a body material and seaming with one or more rows of stitches, and
- (b) turning the top ply back sharply over the first row of stitching and seaming with a second row of stitches through the top and bottom plies.

FIG. 181 Seam Type LSbl-2

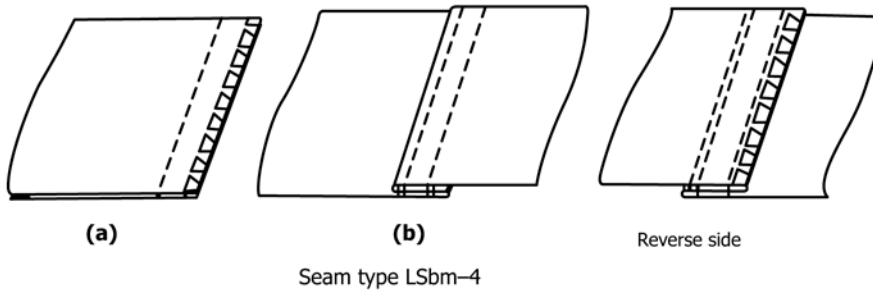
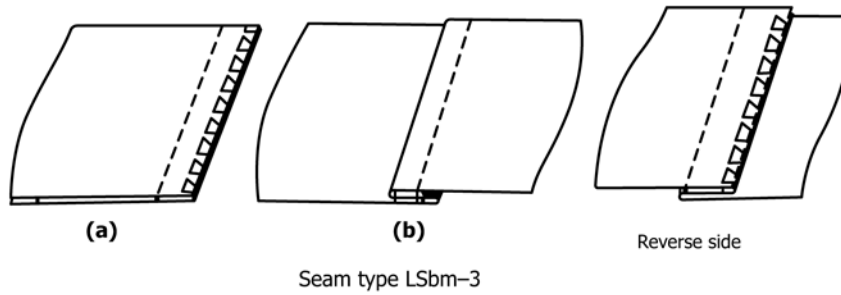

NOTE 1—This type of seam shall be formed by:
 (a) superimposing two plies of material and seaming in seam type SSa-2, with one row of seaming stitches and one row of overedge stitches, and
 (b) turning the top ply back sharply over the seaming row of stitches and seaming with one or more rows of stitches.

FIG. 182 Seam Type LSbm

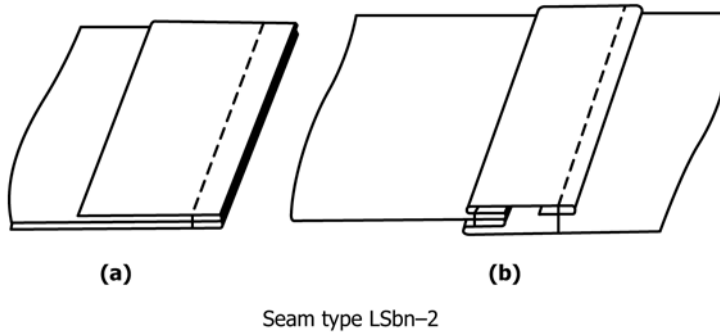

NOTE 1—This type of seam shall be formed by:
 (a) superimposing a strip on two plies of material and seaming with a single row of stitches a specified distance from the edge in seam type SSa-1, and
 (b) turning the bottom ply and the strip over the first row of stitches, turning in the edge of the strip and seaming the turned edge to the bottom ply with one row of stitches.

FIG. 183 Seam Type LSbn-2

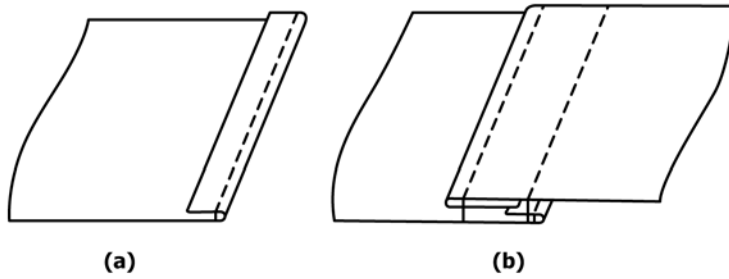

Seam type LSbo-3

NOTE 1—This type of seam shall be formed by:
 (a) turning the edge of a ply of material and stitching the turned portion to the body of the material with one row of stitches, and
 (b) folding the edge of another ply of material, lapping it on the first ply, and seaming with two rows of stitches.

FIG. 184 Seam Type LSbo-3

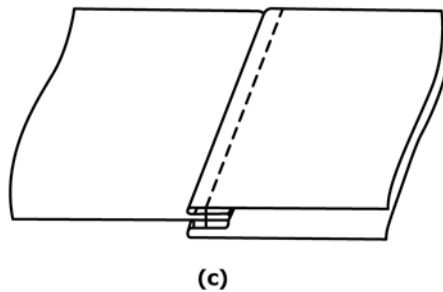
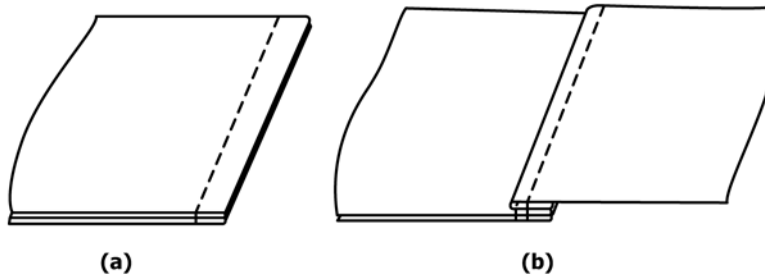

Seam type LSbp-2

NOTE 1—This type of seam shall be formed by:
 (a) superimposing three or more plies of material and seaming with one row of stitches a specified distance from the edge in seam type SSa-1,
 (b) turning the top ply back over the row of stitches and seaming with one or more rows of stitches, and
 (c) turning the bottom ply back to show the finished seam.

FIG. 185 Seam Type LSbp-2

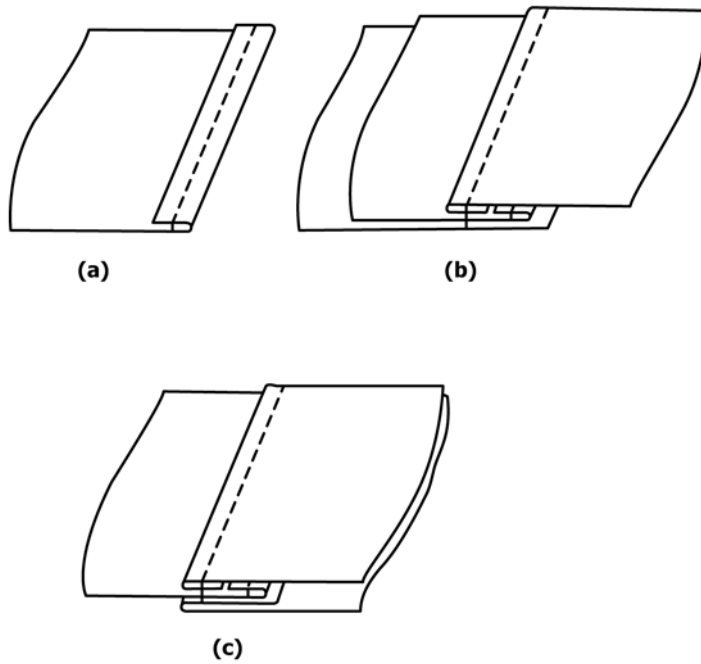

Seam type LSbq-2

NOTE 1—This type of seam shall be formed by:
 (a) turning the edge of a ply of material and stitching the turned portion to the body of the material with one row of stitches,
 (b) superimposing this ply on a second ply of material, folding under the edge of a third ply and lapping it over the turned and stitched edge and seaming with one row of stitches through the folded edge of the third ply and the two other plies of material, and
 (c) turning the bottom ply back to lie under the top ply to show the finished seam.

FIG. 186 Seam Type LSbq-2

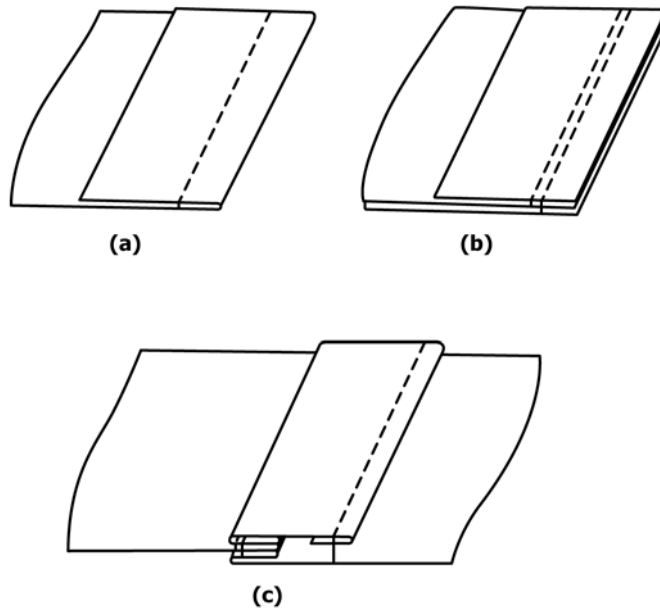

Seam type LSbr-3

NOTE 1—This type of seam shall be formed by:
 (a) superimposing a strip on a ply of material and seaming with a row of stitches a specified distance from the edge in seam type SSa-1,
 (b) superimposing the seam thus formed on another ply of material and seaming with one row of stitches between the first row of stitches and the edge of the plies, and
 (c) turning the bottom ply and the strip over the two rows of stitches, turning in the edge of the strip and seaming the turned edge to the bottom ply with one row of stitches.

FIG. 187 Seam Type LSbr-3

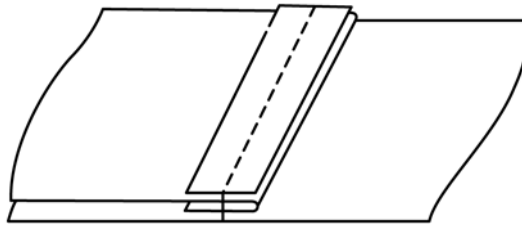

Seam type LSbs-1

NOTE 1—This type of seam shall be formed by folding under the edge of one ply of material, lapping it on the body of another ply of material, superimposing a tape along the folded edge of the first ply, and seaming with one or more rows of stitches.

FIG. 188 Seam Type LSbs-1

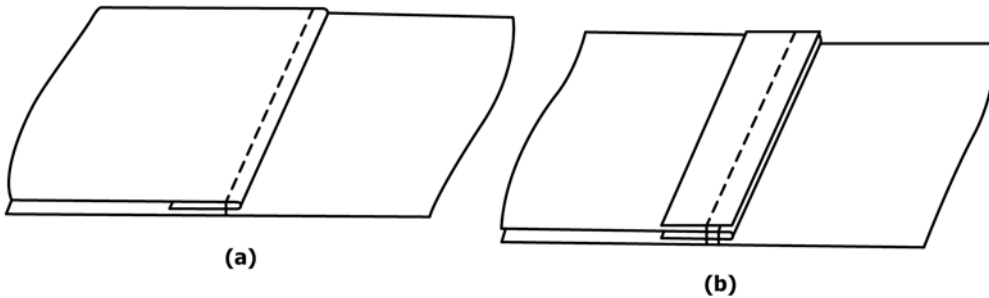

Seam type LSbt-2

NOTE 1—This type of seam shall be formed by:

- (a) folding under the edge of one ply of material, lapping it on the body of another ply of material and seaming with one row of stitches, and
- (b) superimposing a tape along the folded edge of the first ply and seaming with one or more rows of stitches a specified distance from the edge.

FIG. 189 Seam Type LSbt-2

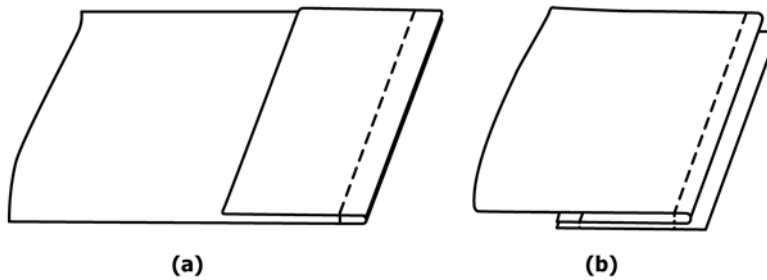

Seam type LSbu-2

NOTE 1—This type of seam shall be formed by:

- (a) superimposing a strip on a body material and seaming a specified distance from the edge in seam type SSa-1, and
- (b) folding the body material a specified distance from the edge of the strip and seaming the folded edge through the strip with one or more rows of stitches.

FIG. 190 Seam Type LSbu

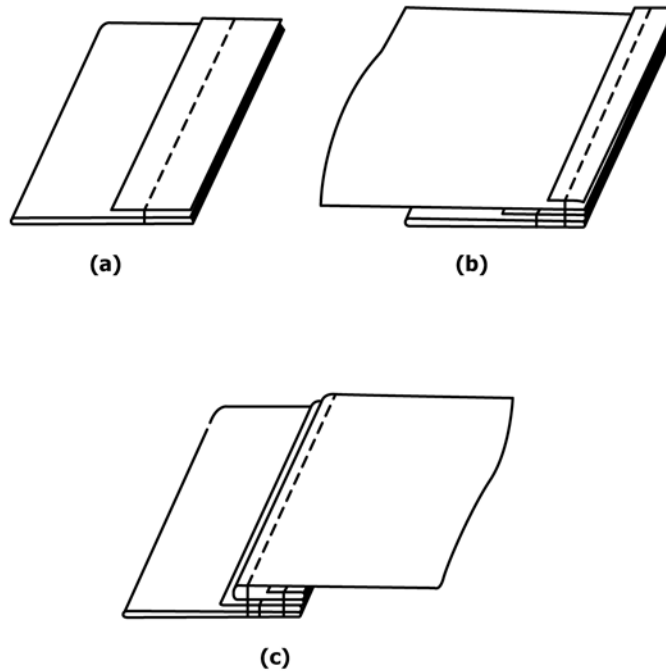

Seam type LSbv-3

NOTE 1—This type of seam shall be formed by:
 (a) superimposing a strip on a folded ply of material and seaming with one row of stitches,
 (b) folding the edge of a body material and superimposing on the seam formed in (a) and seaming through the folded edge of the body material, and
 (c) turning the body material over the seamed edges with the fold a specified distance from the edge of the extending strip and seaming a specified distance from the folded edge with one row of stitches.

FIG. 191 Seam Type LSbv-3

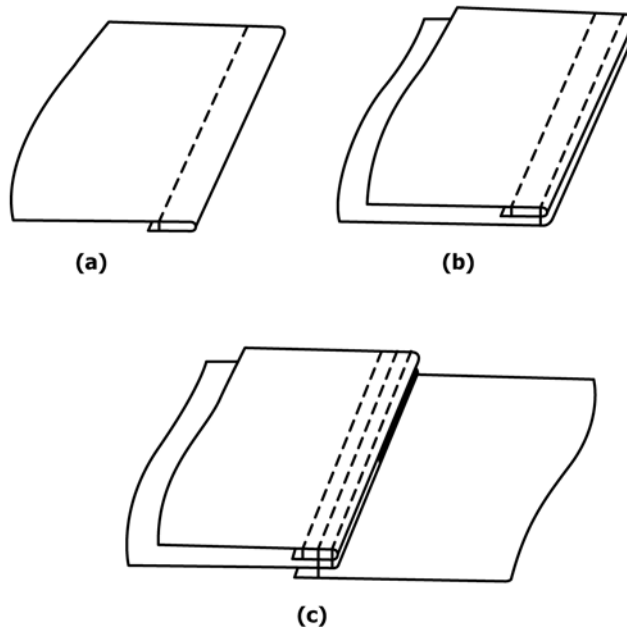

Seam type LSbw-3

NOTE 1—This type of seam shall be formed by:
 (a) superimposing a binding strip on a reinforcing piece and two or more plies of body material and seaming with one row of stitches,
 (b) turning the binding strip over the row of stitches and around the edges of the material, turning the bottom ply outward and stitching through all plies with one row of stitches, and
 (c) seaming the opposite edge of the reinforcing strip to the body material with one row of stitches.

FIG. 192 Seam Type LSbw-3

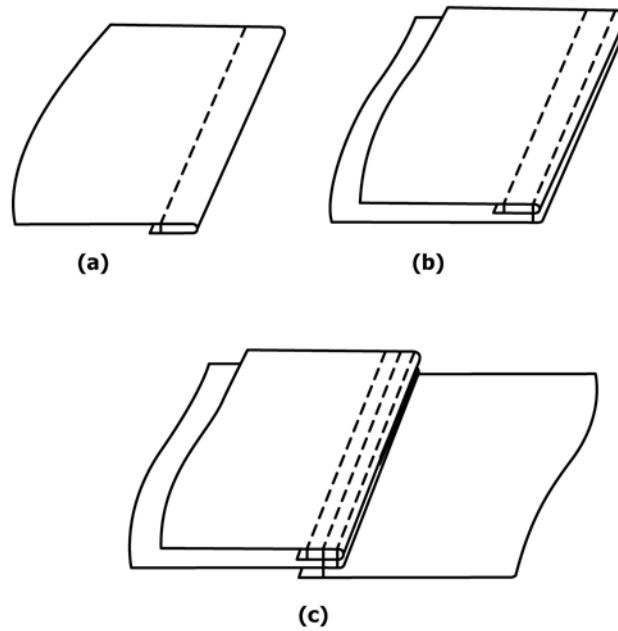

Seam type LSbx-3

NOTE 1—This type of seam shall be formed by:

- (a) turning the edge of one ply of material and stitching the turned portion to the body material a specified distance from the edge as in stitching type EFa-1,
- (b) superimposing the folded edge on another ply of material and seaming through all plies with a row of stitches a specified distance from the folded edge, and
- (c) lapping the superimposed plies on one or more plies and seaming through all plies with a row of stitches a specified distance from the folded edge of top ply.

FIG. 193 Seam Type LSbx-3

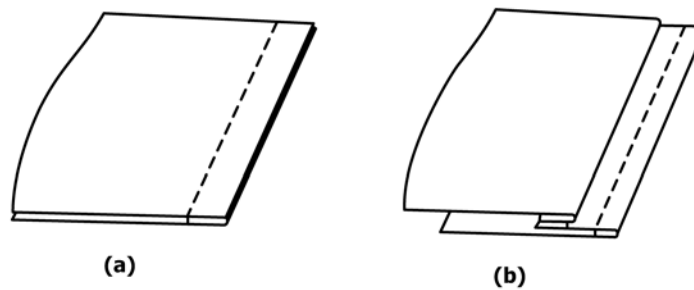

Seam type LSby-2

NOTE 1—This type of seam shall be formed by:

- (a) superimposing two plies of material and seaming in seam type SSa-1, and
- (b) turning the top ply sharply back over the first row of stitches with the bottom ply folded a specified distance, and seaming with one or more rows of stitches through the folded portion of the bottom ply.

FIG. 194 Seam Type LSby-2

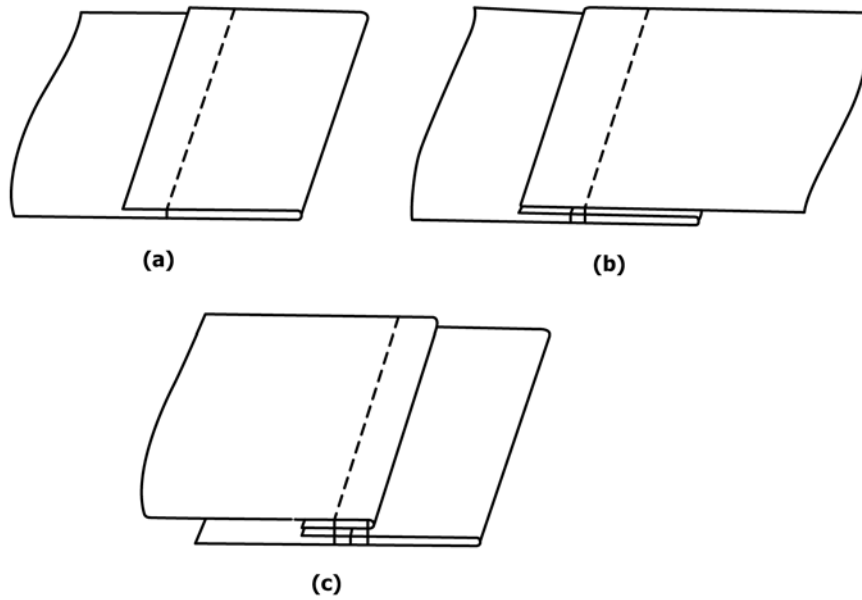

Seam type LSbz-3

NOTE 1—This type of seam shall be formed by:
 (a) folding the edge of a body material a specified distance and seaming with one row of stitches,
 (b) lapping a second ply of material over the folded and seamed ply and seaming with one row of stitches, and
 (c) turning the second ply sharply at the second row of stitches and seaming with one or more rows of stitches.

FIG. 195 Seam Type LSbz-3

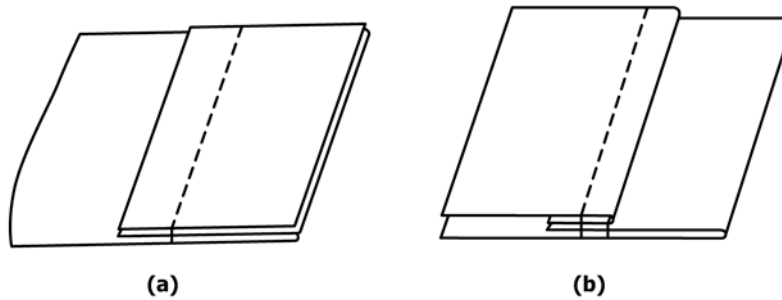

Seam type LSca-2

NOTE 1—This type of seam shall be formed by:
 (a) superimposing a strip on the folded edge of a body material and seaming with one row of stitches a specified distance from the folded edge, and
 (b) turning the strip back sharply over the first row of stitches and seaming with one or more rows of stitches.

FIG. 196 Seam Type LSca-2

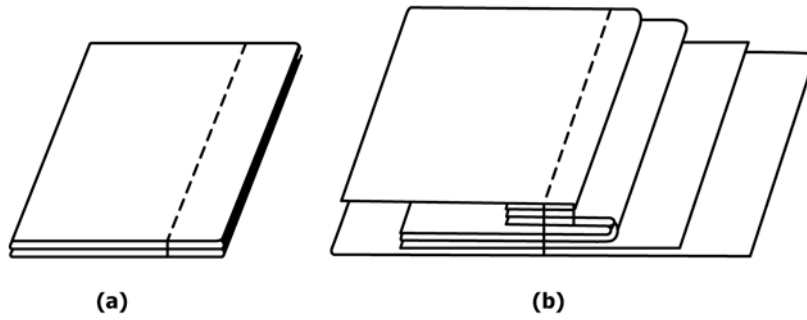

Seam type LScb-2

NOTE 1—This type of seam shall be formed by:

- (a) superimposing three plies of material and seaming in seam type SSa-1, and
- (b) Turning the top ply back over the row of stitches and folding the two bottom plies a specified distance; superimposing this on one or more plies of body material and seaming with one or more rows of stitches.

FIG. 197 Seam Type LScb-2

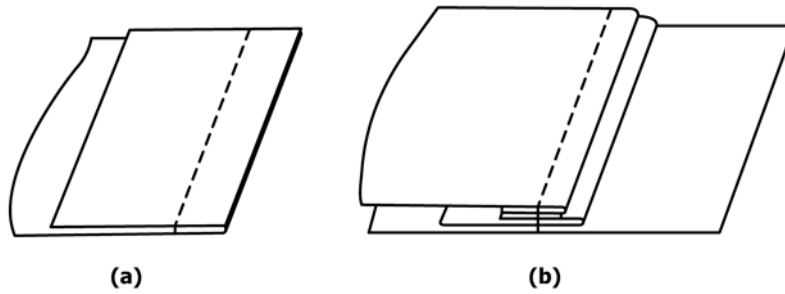

Seam type LScC-2

NOTE 1—This type of seam shall be formed by:

- (a) superimposing two plies of material and seaming in seam type SSa-1, and
- (b) turning both plies of material over their edges, lapping the two plies over a body material and seaming with one or more rows of stitches.

FIG. 198 Seam Type LScC-2

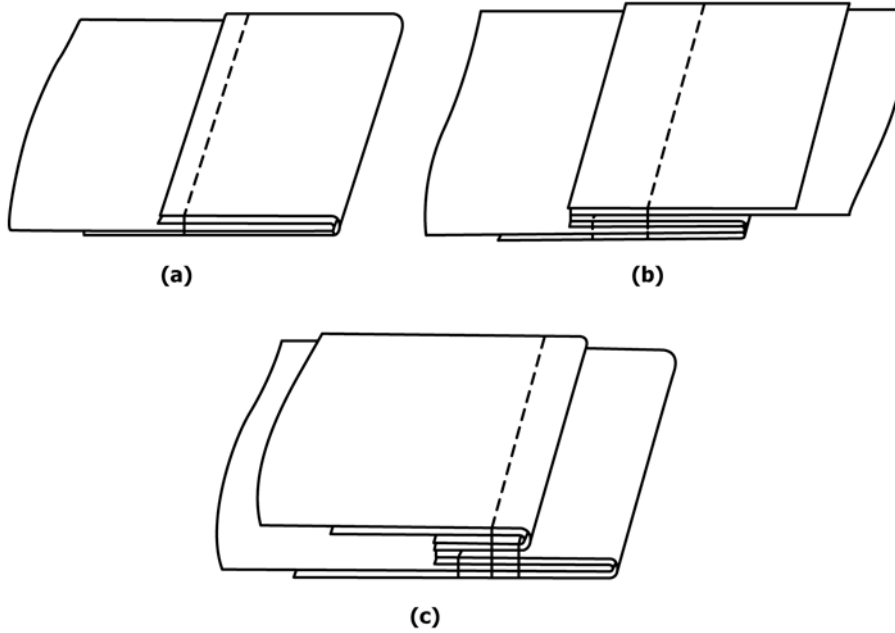

Seam type LScd-3

NOTE 1—This type of seam shall be formed by:

- (a) superimposing two or more plies of material, folding both edges back over the body material a specified distance and seaming with one or more rows of stitches,
- (b) lapping two plies of material even with the folded edges and seaming with one row of stitches, and
- (c) turning the two plies back over the second row of stitches and seaming through all plies with one row of stitches.

FIG. 199 Seam Type LScd-3

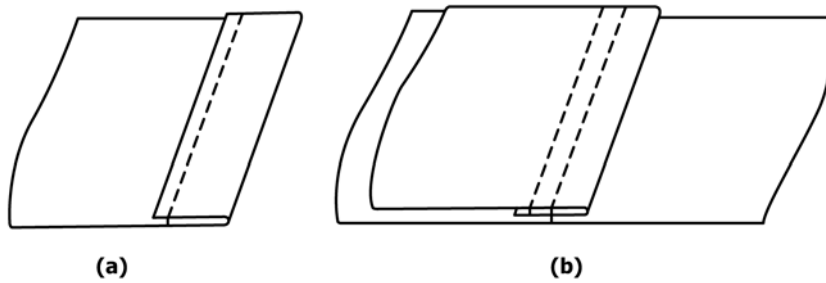

Seam type LSce-2

NOTE 1—This type of seam shall be formed by:

- (a) folding the edge of one ply of material and seaming with one row of stitches a specified distance from the edge, and
- (b) lapping the ply on the body of another ply of material and seaming with one or more rows of stitches.

FIG. 200 Seam Type LSce-2

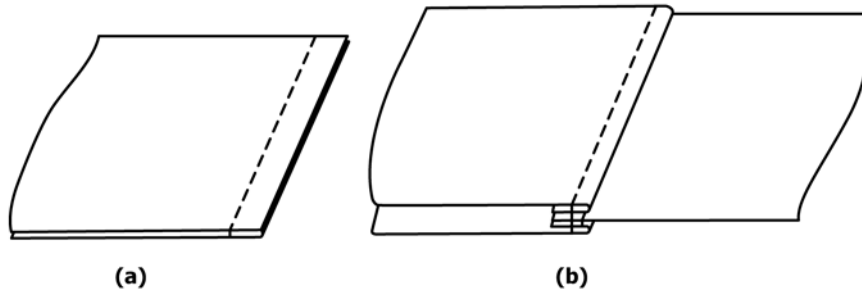

Seam type LScf-2

NOTE 1—This type of seam shall be formed by:

- (a) superimposing and seaming two plies of material in seam type SSa-1, and
- (b) turning the bottom ply at the row of stitches, superimposing a third ply with edge folded and seaming with one or more rows of stitches.

FIG. 201 Seam Type LScf-2

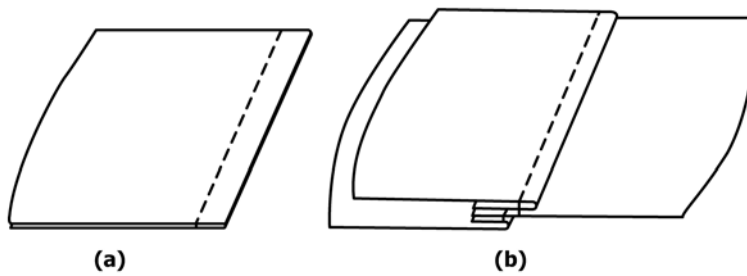

Seam type LScg-2

NOTE 1—This type of seam shall be formed by:

- (a) superimposing and seaming two plies of material in seam type SSa-1, and
- (b) turning the bottom ply at the row of stitches, superimposing a third ply with edge folded and seaming to the top ply with one row of stitches through the folded edge.

FIG. 202 Seam Type LScg-2

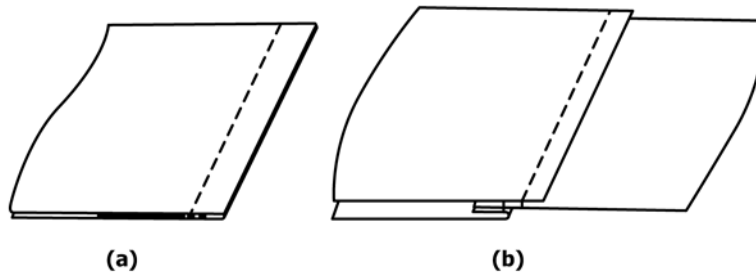

Seam type LSch-2

NOTE 1—This type of seam shall be formed by:

- (a) superimposing and seaming two plies of material in seam type SSa-1, and
- (b) turning the bottom ply at the row of stitches, superimposing a third ply and seaming with one row of stitches through the third ply and top ply.

FIG. 203 Seam Type LSch-2

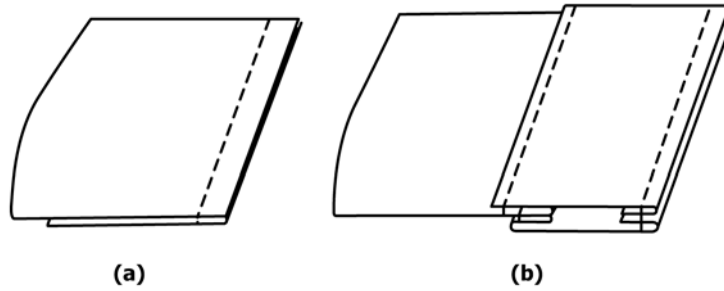

Seam type LScj-3

NOTE 1—This type of seam shall be formed by:
 (a) superimposing two plies of material and seaming in seam type SSa-1, and
 (b) turning the bottom ply at the row of stitches and folding in the raw edge; superimposing a strip with one edge folded and seaming with two rows of stitches; one row through the folded edges and one row through the strip and the body material.

FIG. 204 Seam Type LScj-3

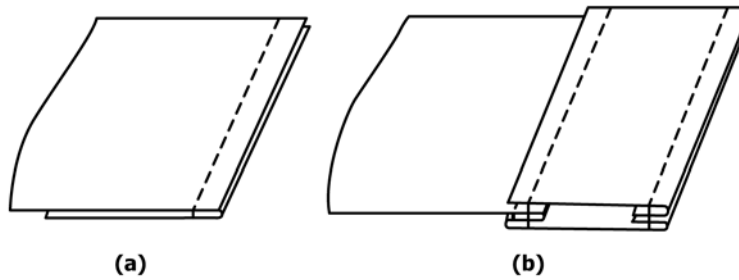

Seam type LScK-3

NOTE 1—This type of seam shall be formed by:
 (a) superimposing two plies of material and seaming in seam type SSa-1, and
 (b) turning the bottom ply at the row of stitches and folding in the raw edge; superimposing a strip with one edge folded and seaming with two or more rows of stitches.

FIG. 205 Seam Type LScK-3

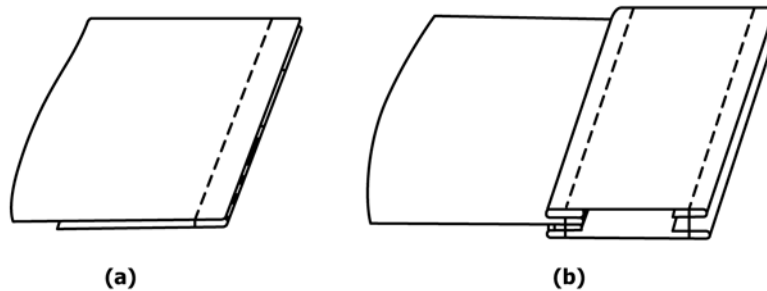

NOTE 1—This type of seam shall be formed by:
 (a) superimposing two plies of material and seaming in seam type SSa-1, and
 (b) turning the bottom ply at the row of stitches, folding in the raw edge; folding in both edges of another ply of material, lapping it on the turned and folded ply and seaming with two or more rows of stitches.

FIG. 206 Seam Type LScI-3

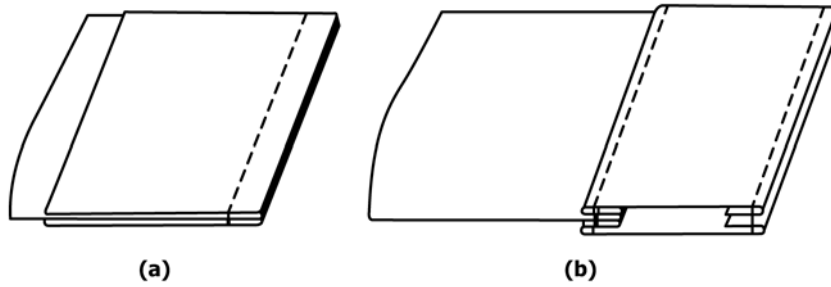

NOTE 1—This type of seam shall be formed by:
 (a) placing two strips on either side of a body material and seaming with one row of stitches, and
 (b) turning the strips back over the sewn edges, folding in the raw edges of the strips and seaming each side with one row of stitches.

FIG. 207 Seam Type LScm-3

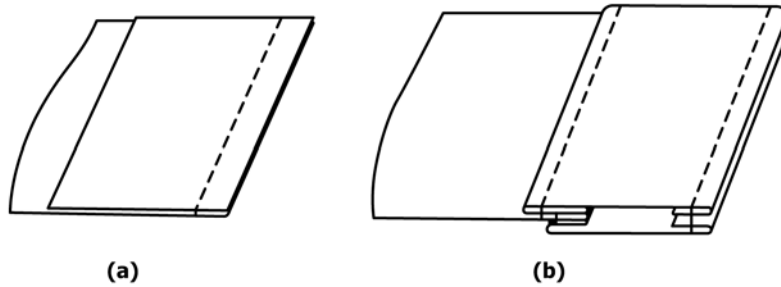

NOTE 1—This type of seam shall be formed by:
 (a) superimposing two plies of material and seaming in seam type SSa-1, and
 (b) turning the bottom ply at the row of stitches, folding in the raw edges; folding in both edges of another ply of material, lapping it on the turned and folded ply and seaming with two or more rows of stitches, one row of which shall be through the body ply.

FIG. 208 Seam Type LScn-3

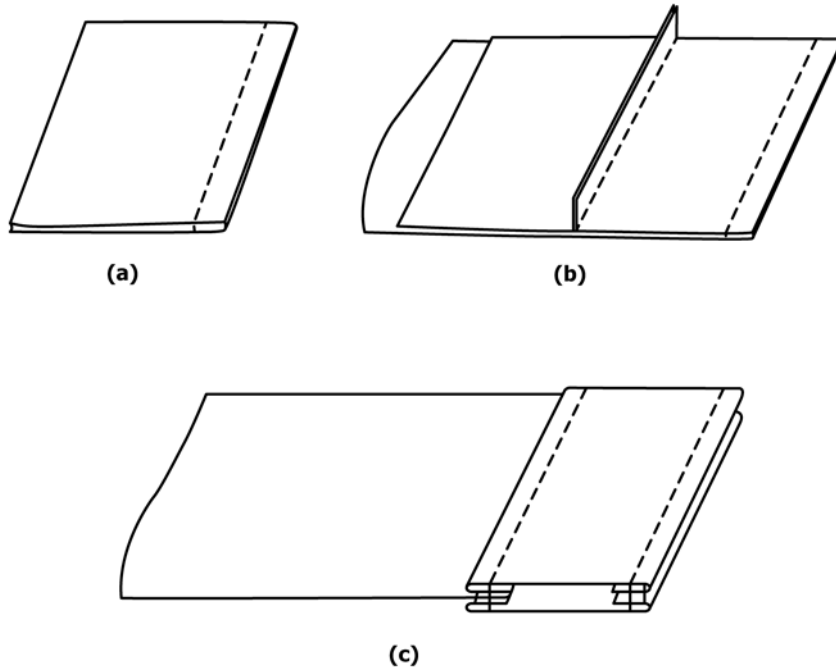

NOTE 1—This type of seam shall be formed by:
 (a) superimposing two strips and seaming with one row of stitches in seam type SSa-1,
 (b) seaming the edge of one of the strips to a body material, and
 (c) turning the strips to cover the raw edges, folding in the raw edge of the top strip and seaming with two or more rows of stitches.

FIG. 209 Seam Type LScO-4

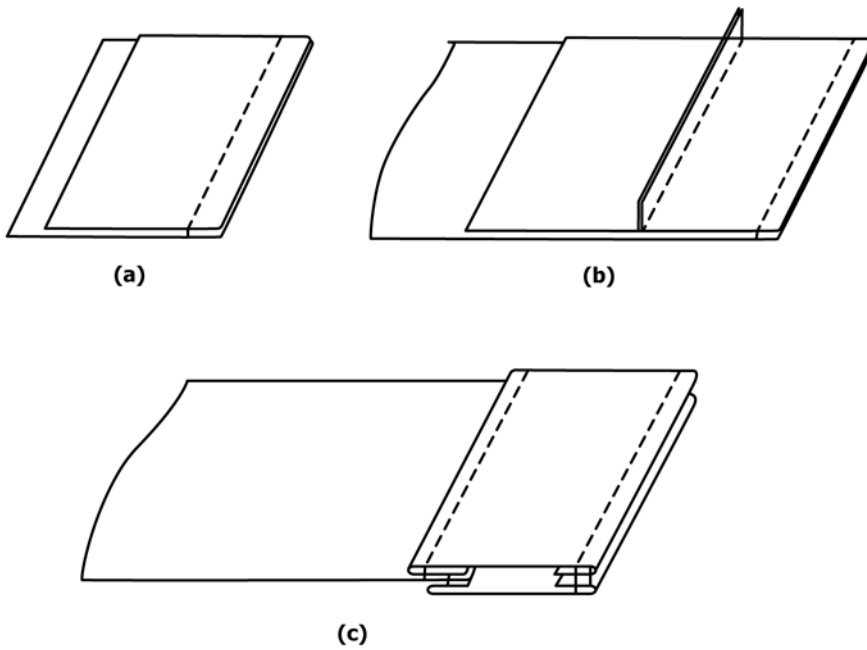

NOTE 1—This type of seam shall be formed by:
 (a) superimposing two strips and seaming with one row of stitches in seam type SSa-1,
 (b) seaming the edge of one of the strips to a body material, and
 (c) turning the strips to cover the raw edges, folding in the raw edge of the top strip and seaming through the body material. The outer edge shall be seamed with one row of stitches.

FIG. 210 Seam Type LScP-4

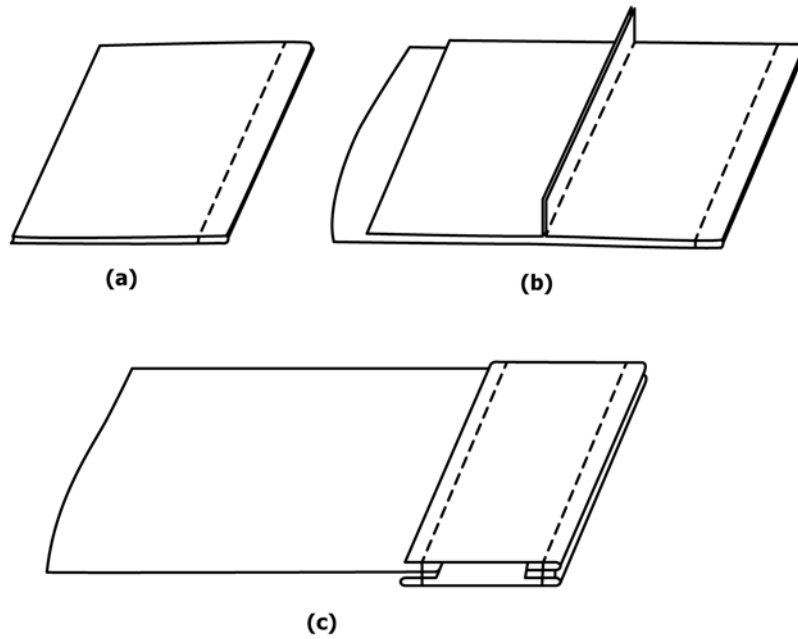

NOTE 1—This type of seam shall be formed by:
 (a) superimposing two strips and seaming with one row of stitches in seam type SSa-1,
 (b) seaming the edge of one of the strips to a body material, and
 (c) turning the strip to cover the raw edges and seaming with two or more rows of stitches.

FIG. 211 Seam Type LScq-4

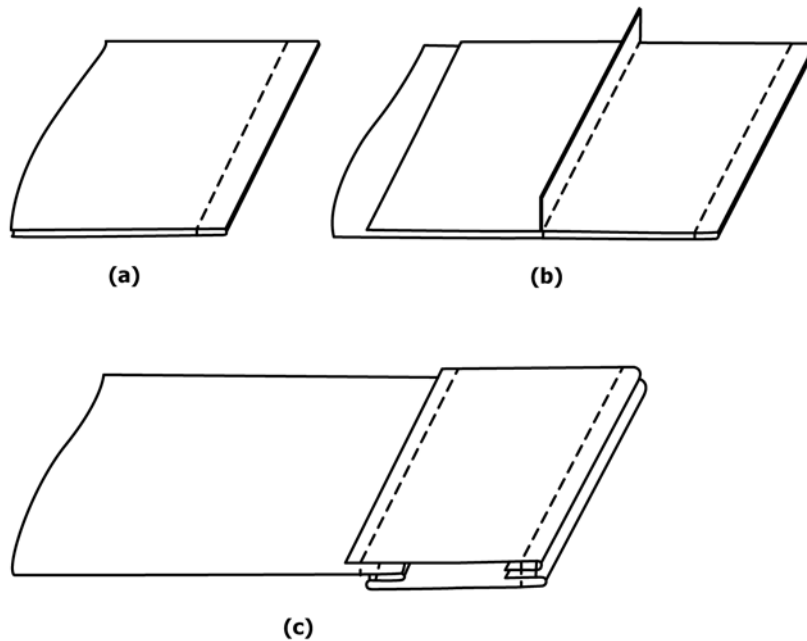

NOTE 1—This type of seam shall be formed by:
 (a) superimposing two strips and seaming with one row of stitches in seam type SSa-1,
 (b) seaming the edge of one of the strips to a body material, and
 (c) turning the strips to cover the raw edges, and seaming the unturned edge through the body material. The outer edge shall be seamed with one row of stitches.

FIG. 212 Seam Type LScr-4

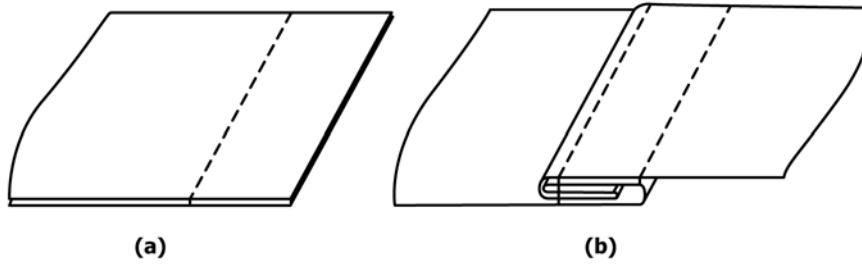

NOTE 1—This type of seam shall be formed by:
 (a) superimposing two plies of material and seaming in seam type SSa-1, and
 (b) opening the plies of fabric, turning the seam allowance to one side with the raw edges turned under, and seaming with one or more rows of stitches.

FIG. 213 Seam Type LScs-2

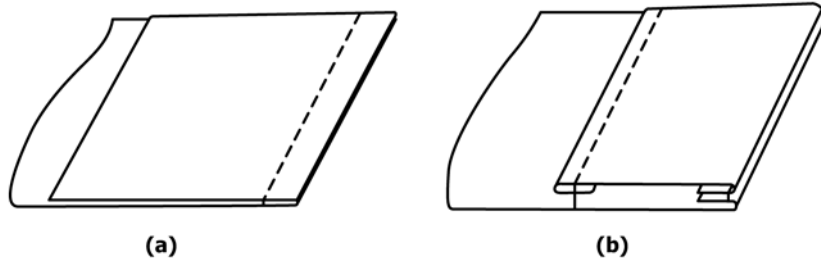

NOTE 1—This type of seam shall be formed by:
 (a) superimposing a strip on a body material and seaming with one row of stitches in seam type SSa-1, and
 (b) turning both plies over their edges, turning under the opposite edge of the strip and seaming with one or more rows of stitches.

FIG. 214 Seam Type LSct-2

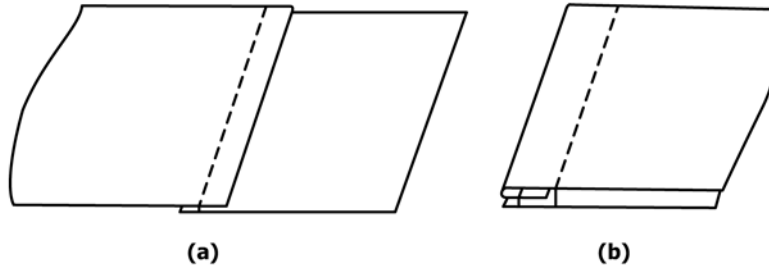

NOTE 1—This type of seam shall be formed by:
 (a) overlapping two plies of material and seaming with a row of stitches a specified distance from the edges, and
 (b) turning the top ply over the first row of stitching and seaming with a row of stitches through the body material.

FIG. 215 Seam Type LScu-2

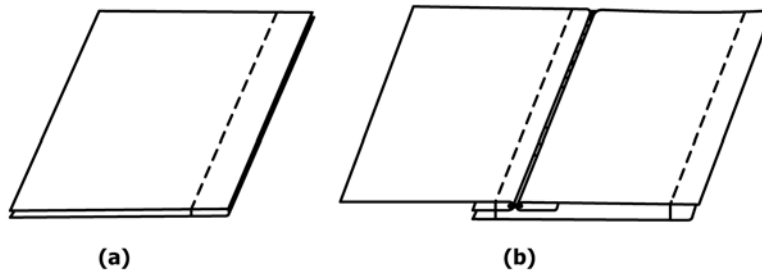

NOTE 1—This type of seam shall be formed by:
 (a) superimposing and seaming two plies of material in seam type SSa-1, and
 (b) opening the two plies, turning the edge of each ply under the body, superimposing on a third ply of material and seaming with two rows of stitches.

FIG. 216 Seam Type LScv-3

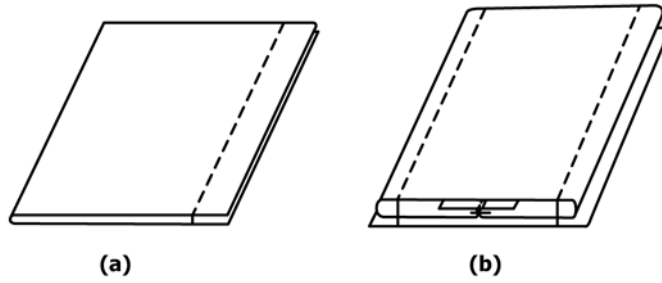

NOTE 1—This type of seam shall be formed by:
 (a) folding a piece of material and seaming a specified distance from the edge, and
 (b) turning the material inside out with the seam opened and centered, and seaming to a body material with two rows of stitches.

FIG. 217 Seam Type LScv-3

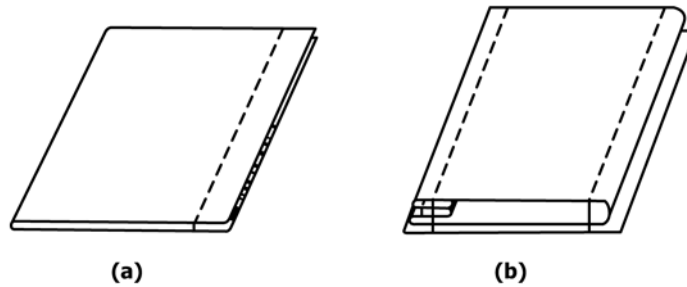

NOTE 1—This type of seam shall be formed by:
 (a) folding a piece of material and seaming a specified distance from the edge, and
 (b) turning the material inside out with the seam to one side and seaming to a body material with two rows of stitches.

FIG. 218 Seam Type LScx-3

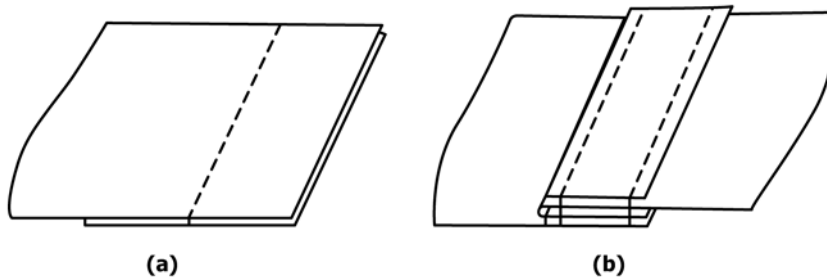

NOTE 1—This type of seam shall be formed by:
 (a) superimposing two plies of material in seam type SSa-1, and
 (b) turning the top ply back sharply over the first row of stitches, superimposing a strip and seaming with two or more rows of stitches through all plies.

FIG. 219 Seam Type LScy-3

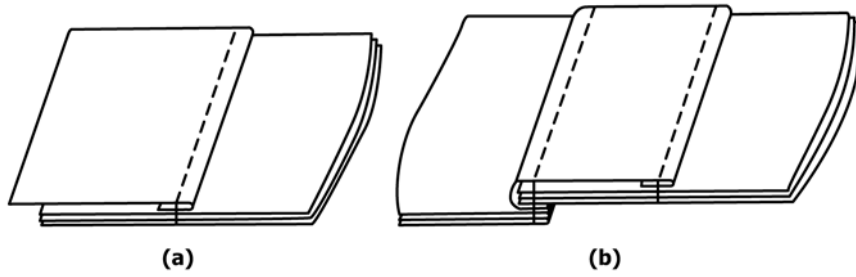

NOTE 1—This type of seam shall be formed by:
 (a) folding under the edge of one ply of material; lapping it on two plies of body material and seaming with one row of stitches, and
 (b) folding the edge of the first ply around the edges of the body plies; superimposing this on the edge of two additional plies of material, and seaming through all plies with one row of stitches.

FIG. 220 Seam Type LScz-2

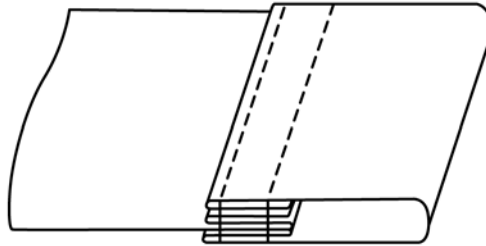

NOTE 1—This type of seam shall be formed by turning the edge of one ply of material in an “S” fold, superimposing it on another ply with the edges even; turning both edges of a strip and folding it over the plies of body materials, and seaming with two rows of stitches.

FIG. 221 Seam Type LSda-2

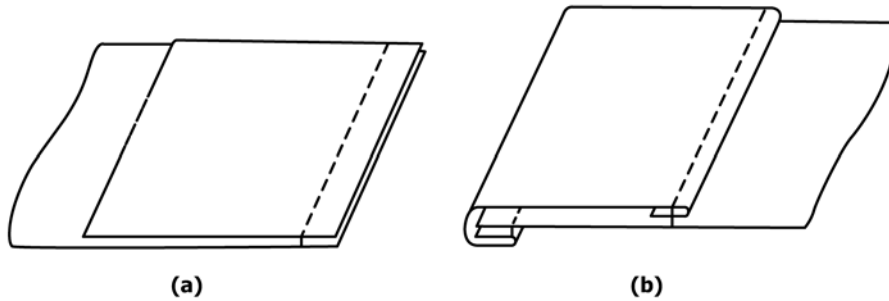

NOTE 1—This type of seam shall be formed by:
 (a) superimposing a strip on a body material and seaming in seam type SSa-1, and
 (b) turning the strip around the edge of the body material; turning under the raw edge of the strip and seaming to the body material with one row of stitches.

FIG. 222 Seam Type LSdb-2

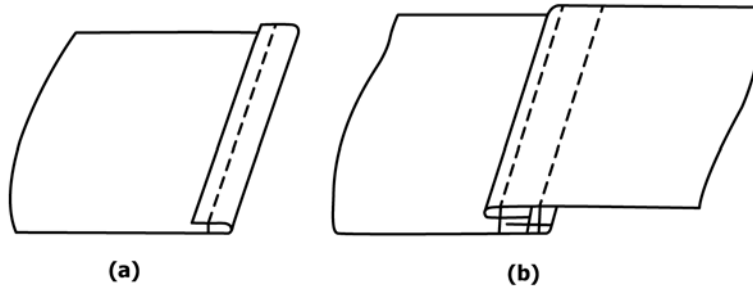

NOTE 1—This type of seam shall be formed by:
 (a) turning the edge of a ply of material and stitching in stitching type EFa-1, and
 (b) turning the edge of a second ply of material and lapping it on the turned and stitched edge of the first ply, and seaming with two rows of stitches.

FIG. 223 Seam Type LSdc-3

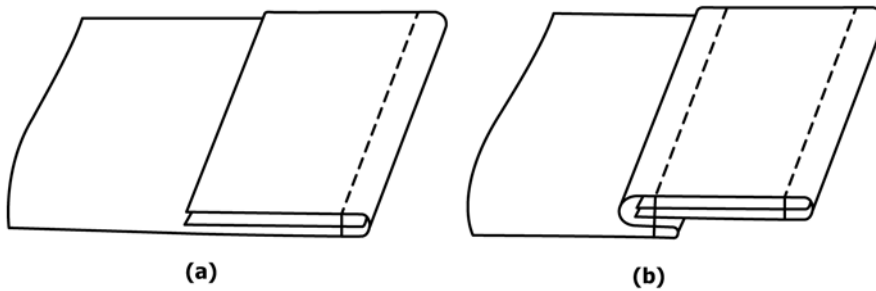

NOTE 1—This type of seam shall be formed by:
 (a) lapping an interlining strip over a ply of material, turning the edge of the material around the strip and seaming with one row of stitches, and
 (b) folding the material in an "S" fold over the opposite edge of the strip and the edge of the body material, and seaming with one row of stitches.

FIG. 224 Seam Type LSdd-2

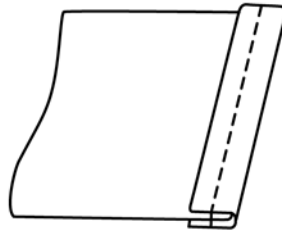

Seam type BSa-1

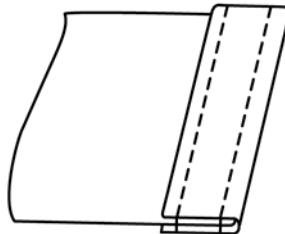

Seam type BSa-2

NOTE 1—This type of seam shall be formed by folding a binding strip over the edge of the ply or plies of body material and seaming the binding strip and body material with one or more rows of stitches.

FIG. 225 Seam Type BSa

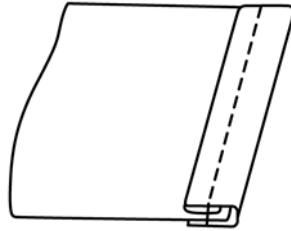

Seam type BSb-1

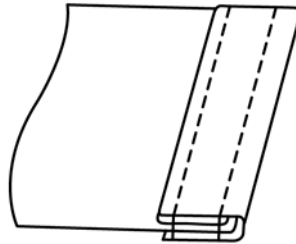

Seam type BSb-2

NOTE 1—This type of seam shall be formed by turning one edge of a binding strip, folding it over the edge of the ply or plies of body material, and seaming the binding strip and body material with one or more rows of stitches.

FIG. 226 Seam Type BSb

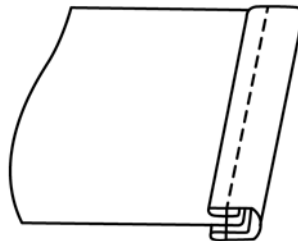

Seam type BSc-1

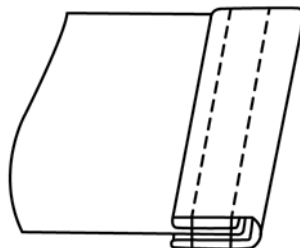

Seam type BSc-2

NOTE 1—This type of seam shall be formed by turning both edges of a binding strip, folding it over the edge of the ply or plies of body material, and seaming the binding strip and body material with one or more rows of stitches.

FIG. 227 Seam Type BSc

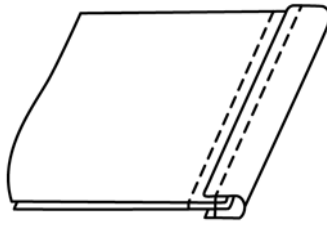

NOTE 1—This type of seam shall be formed by folding a binding strip over the edges of the plies of body material, seaming the binding strip and body material with one row of stitches, and the plies of body material with a second row of stitches a substantial distance from the edge.

FIG. 228 Seam Type BSd-2

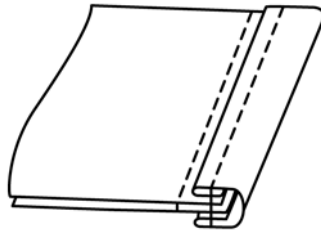

NOTE 1—This type of seam shall be formed by turning both edges of a binding strip and folding it over the edge of the plies of body material, seaming the binding strip and body material with one row of stitches and the two plies of body material with another row of stitches a substantial distance from the edge.

FIG. 229 Seam Type BSe-2

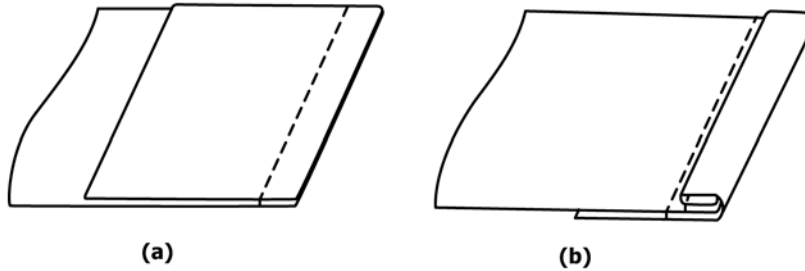

NOTE 1—This type of seam shall be formed by:
 (a) superimposing a strip on a ply of body material and seaming with one row of stitches in seam type SSa-1, and
 (b) turning the strip over the row of stitches around the edge of the body material and seaming with a second row of stitches.

FIG. 230 Seam Type BSf-2

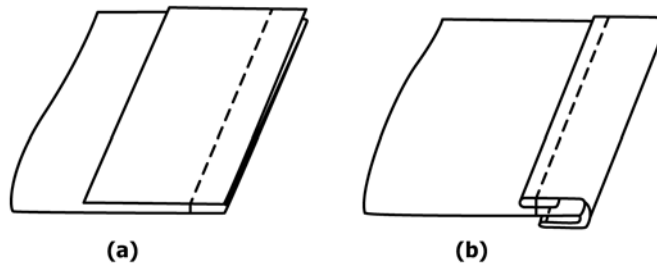

NOTE 1—This type of seam shall be formed by:
 (a) superimposing a strip on a ply of body material and seaming with one row of stitches in seam type SSa-1, and
 (b) turning the strip over the row of stitches around the edge of the body material, folding the edge of the strip, and seaming with a second row of stitches.

FIG. 231 Seam Type BSg-2

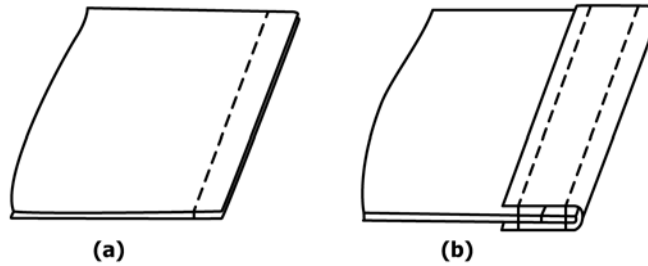

NOTE 1—This type of seam shall be formed by:
 (a) superimposing two plies of material and seaming as in seam type SSa-1, and
 (b) folding a binding strip over the edges of the plies of the body material and seaming with two rows of stitches.

FIG. 232 Seam Type BSh-3

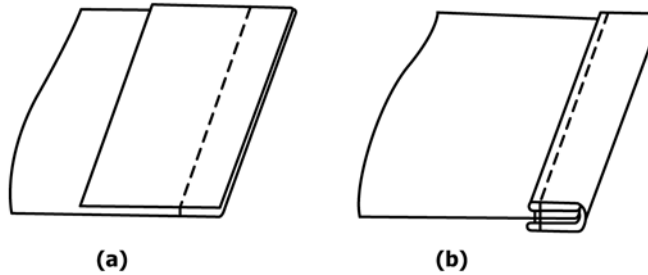

NOTE 1—This type of seam shall be formed by:
 (a) superimposing a strip on a ply of body material and seaming with one row of stitches in seam type SSa-1, and
 (b) turning the strip around the edge of the body material, folding the edge of the strip, and seaming with a second row of stitches through all plies.

FIG. 233 Seam Type BSj-2

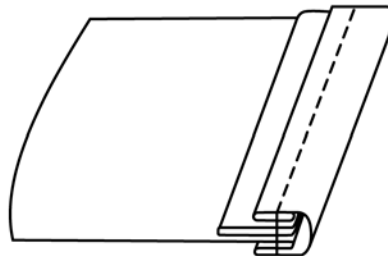

NOTE 1—This type of seam shall be formed by turning both edges of a binding strip, folding it over the edges of a ply or plies of body material and a folded welt strip, and seaming through the binding strip, welt, and body material with one or more rows of stitches.

FIG. 234 Seam Type BSK-1

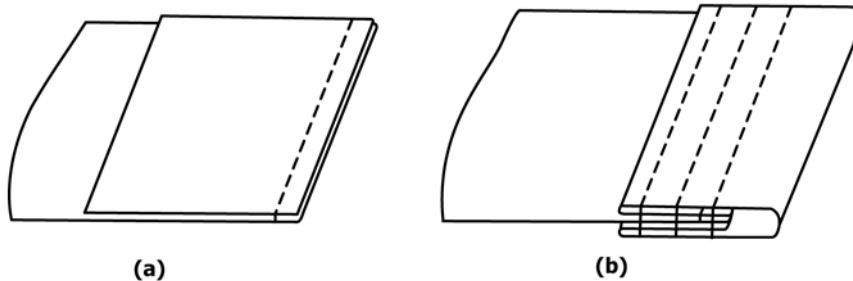

NOTE 1—This type of seam shall be formed by:
 (a) superimposing a strip on a ply of body material and seaming with one row of stitches in seam type SSa-1, and
 (b) turning the strip around the edge of the body material, folding the edge of the strip and seaming with three or more rows of stitches.

FIG. 235 Seam Type Ba1-4

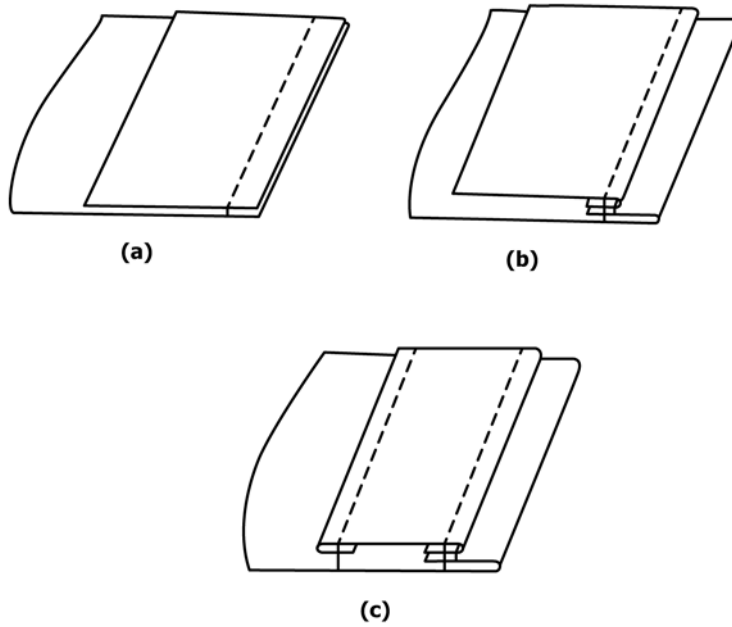

NOTE 1—This type of seam shall be formed by:
 (a) superimposing a strip on a ply of body material and seaming with one row of stitches in seam type SSa-1,
 (b) turning the strip at the row of stitching, folding the body material inward a specified distance, and seaming with one row of stitches, and
 (c) turning the opposite edge of the strip under and seaming through the body material.

FIG. 236 Seam Type BSm-3

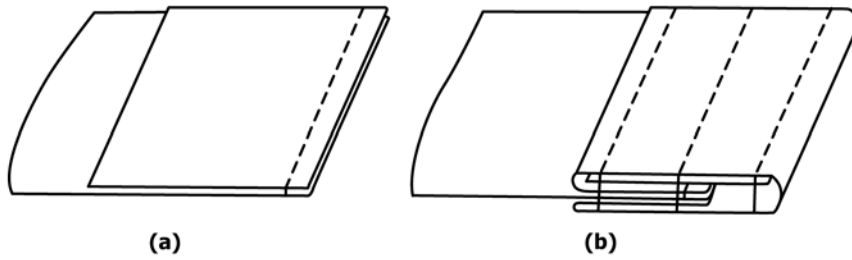

NOTE 1—This type of seam shall be formed by:
 (a) superimposing a strip on a ply of body material and seaming with one row of stitches in seam type SSa-1, and
 (b) turning the strip around the edge of the body material with a tape or webbing inserted, folding the edge of the strip and seaming with three or more rows of stitches.

FIG. 237 Seam Type BSn-4

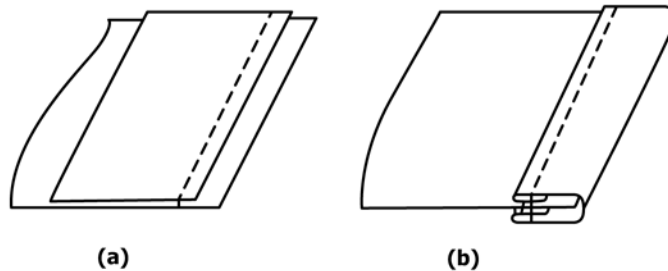

NOTE 1—This type of seam shall be formed by:
 (a) superimposing a strip on a ply of body material a specified distance from the edge and seaming with one row of stitches in seam type SSbd-1, and
 (b) turning the strip over the row of stitching around the edge of the body material, folding the edge of strip, and seaming with a second row of stitches.

FIG. 238 Seam Type BSo-2

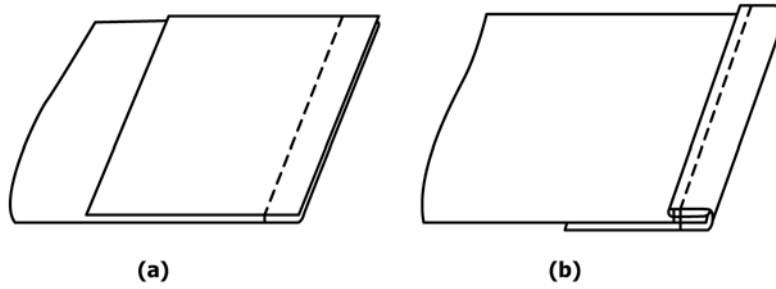

NOTE 1—This type of seam shall be formed by:
 (a) superimposing a strip on a ply of body material and seaming with one row of stitches in seam type SSa-1, and
 (b) turning the strip over the row of stitches around the edge of the body material and seaming with a second row of stitches through the turned edge of the strip.

FIG. 239 Seam Type BSp-2

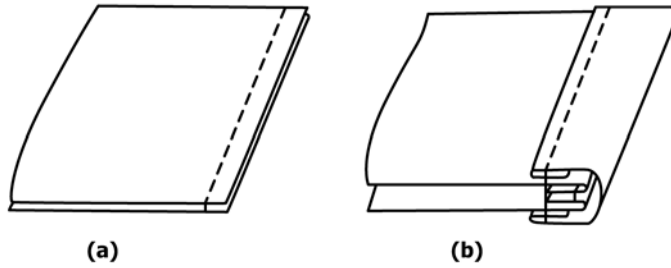

NOTE 1—This type of seam shall be formed by:
 (a) superimposing two plies of material and seaming with one row of stitches in seam type SSa-1, and
 (b) turning both edges of a binding strip and folding it over the edges of the plies of body material, and seaming the binding strip and body material with one row of stitches.

FIG. 240 Seam Type BSq-2

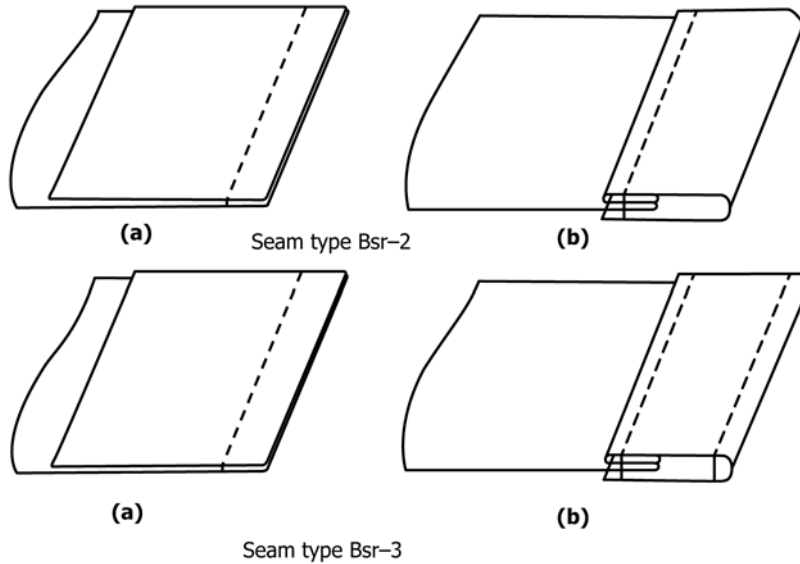

NOTE 1—This type of seam shall be formed by:
 (a) superimposing a strip on a ply of body material and seaming with one row of stitches in seam type SSa-1, and
 (b) turning the strip over the row of stitches around the edge of the body material and seaming with one or more rows of stitches.

FIG. 241 Seam Type Bsr

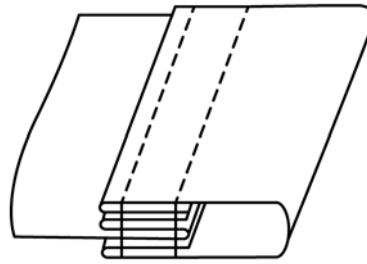

NOTE 1—This type of seam shall be formed by folding the edge of the body material in an “S” fold, turning both edges of a binding strip and folding it over the folded edge of the body material, and seaming the binding strip and body material with two or more rows of stitches.

FIG. 242 Seam Type BSs-2

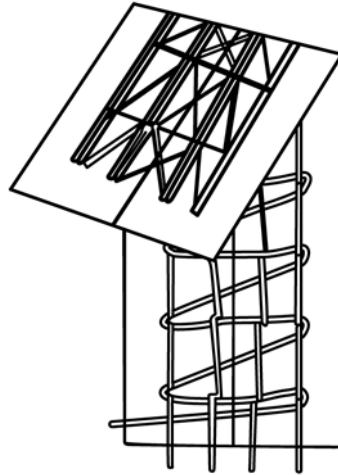

NOTE 1—This type of seam shall be formed by seaming the edges of two or more plies of material with a row of stitches extending across and covering the edges of the material.

FIG. 243 Seam Type FSa-1

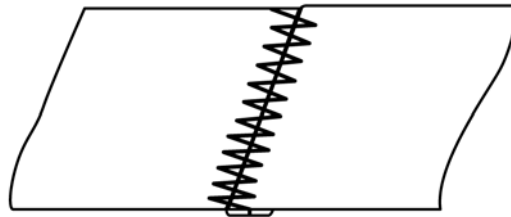

NOTE 1—This type of seam shall be formed by turning the edge of one ply of material, abutting it against the raw edge of a second ply of material and seaming with a row of stitches extending across and covering the turned edge of the first ply and the raw edge of the second ply.

FIG. 244 Seam Type FSb-1

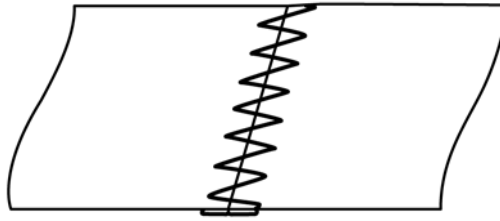

NOTE 1—This type of seam shall be formed by turning and abutting the turned edges of two plies of material and seaming with a row of stitches extending across and covering the turned edges of the material.

FIG. 245 Seam Type FSc-1

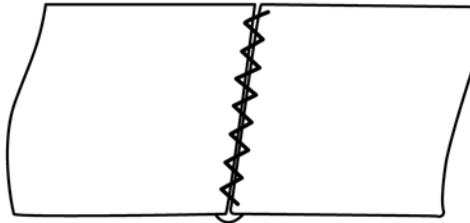

(a)

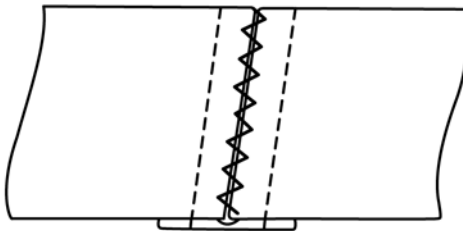

(b)

NOTE 1—This type of seam shall be formed by:
 (a) seaming the edges of two plies of material in seam type FSa-1; and
 (b) seaming a reinforcing tape over or under the seam with two rows of stitches a specified distance apart.

FIG. 246 Seam Type FSd-3

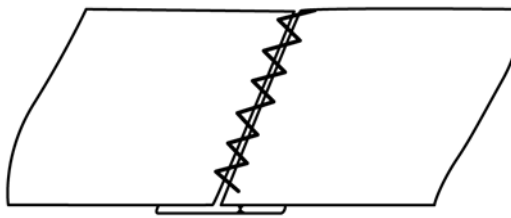

NOTE 1—This type of seam shall be formed by abutting the edges of two pieces of material over a reinforcing strip and seaming with a row of stitches extending across and covering the edges of the material.

FIG. 247 Seam Type FSe-1

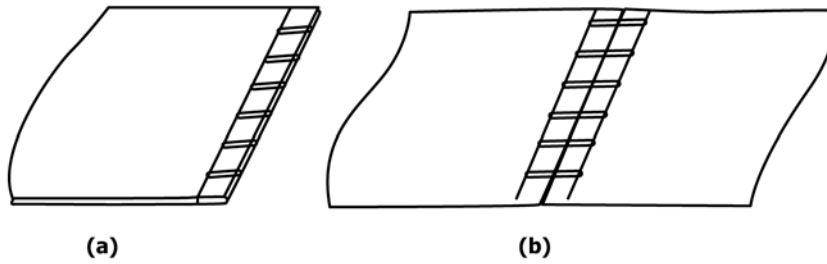

NOTE 1—This type of seam shall be formed by:
 (a) superimposing two plies of material and seaming with an overedge stitch in seam type SSa-1, and
 (b) opening the two plies of material to form a flat seam with the edges of the material abutted.

FIG. 248 Seam Type FSf-1

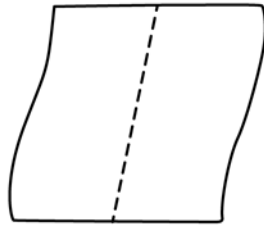

Stitching type OSa-1

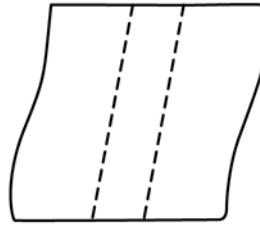

Stitching type OSa-2

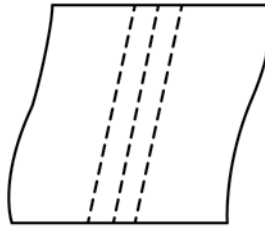

Stitching type OSa-3

NOTE 1—This type of stitching shall be produced with one or more straight rows of stitches.

FIG. 249 Stitching Type Osa

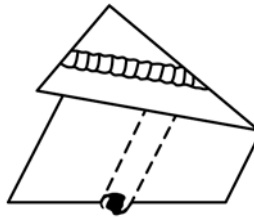

NOTE 1—This type of stitching shall be produced by inserting a cord between the material and the locking thread of the stitch thus forming a ridge or corded effect.

FIG. 250 Stitching Type OSb-1

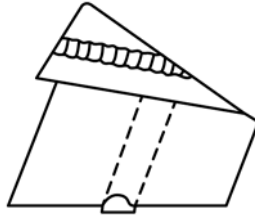

NOTE 1—This type of stitching shall be produced by forming the material in a ridge to give a corded effect without inserting a cord.

FIG. 251 Stitch Type Osc-1

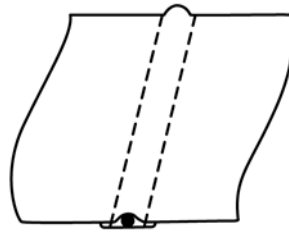

Stitching type OSd-2

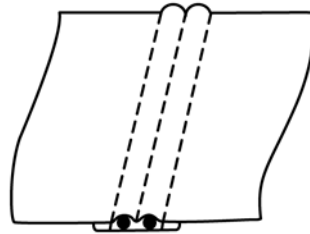

Stitching type OSd-3

NOTE 1—This type of stitching shall be produced by inserting a cord or cords between two plies of material and stitching with a row of stitches on each side of the cord or cords.

FIG. 252 Stitch Type Osd

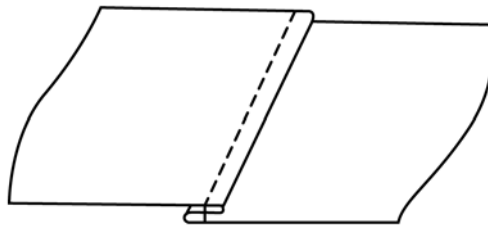

NOTE 1—This type of stitching shall be produced by folding the material in an "S" or reverse "S" fold as specified and stitching the fold to the body material with one or more rows of stitches.

FIG. 253 Stitching Type Ose-1

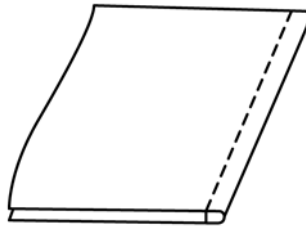

NOTE 1—This type of stitching shall be produced by folding and stitching plies of the material near the fold with one or more rows of stitches.

FIG. 254 Stitching Type OSf-1

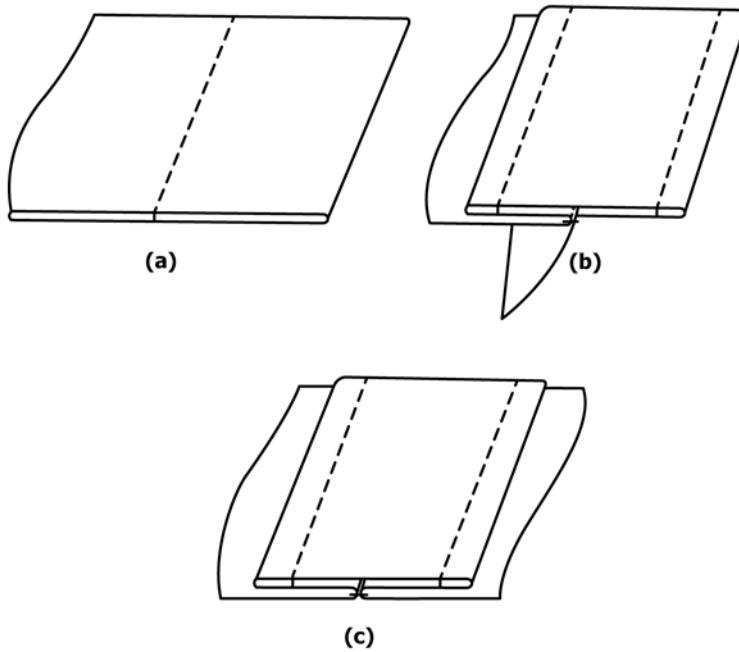

NOTE 1—This type of stitching shall be produced by:
 (a) folding a piece of material and stitching a specified distance from the fold with one row of stitches,
 (b) distributing an equal amount of the material in the fold to each side of the seam, turning each ply aside separately and stitching a specified distance from each folded edge with one row of stitches, and
 (c) opening both plies of material to finish as shown.

FIG. 255 Stitching Type OSg-3

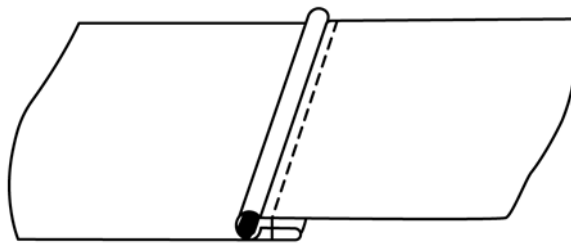

NOTE 1—This type of stitching shall be produced by folding the material in an “S” or reverse “S” fold as specified, inserting a cord in the fold, and stitching the fold to the body material with one or more rows of stitches.

FIG. 256 Stitching Type OSh-1

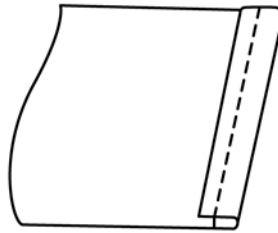

Stitching type EFa-1

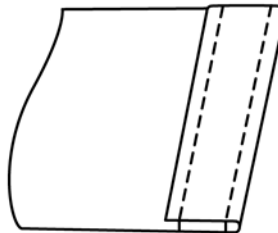

Stitching type EFa-2

NOTE 1—This type of stitching shall be produced by turning the edge of the material and stitching the turned portion to the body of the material with one or more rows of stitches.

FIG. 257 Stitching Type EFa

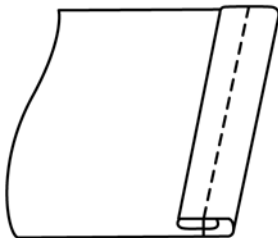

Stitching type EFb-1

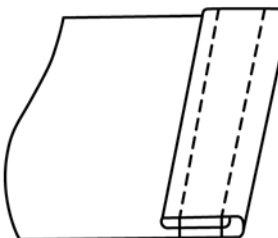

Stitching type EFb-2

NOTE 1—This type of stitching shall be produced by turning the edge of the material, folding it back over the body of the material, and stitching the turned and folded portion to the body of the material with one or more rows of stitches.

FIG. 258 Stitching Type EFb

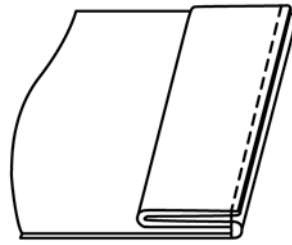

(a)

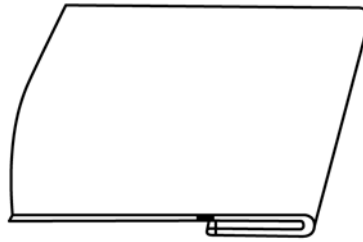

(b)

NOTE 1—This type of stitching shall be produced by folding the edge of the material in an “S” fold and stitching the turned portion to the body with one row of stitches. In sewing, the material shall be so guided that the needle only partially penetrates the folded edge. When the material is laid flat, the stitches shall not show on the outer face of the material.

FIG. 259 Stitching Type Efc-1

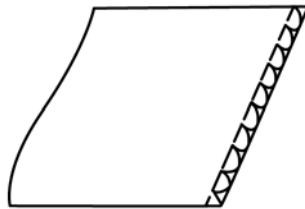

NOTE 1—This type of stitching shall be produced by placing a row of stitches over the edge of the material.

FIG. 260 Stitching Type Efd-1

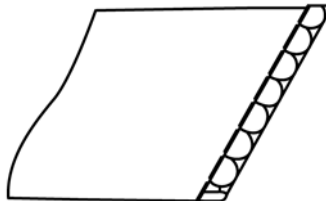

NOTE 1—This type of stitching shall be produced by turning the edge of the material and placing a row of stitches over the edge of the material.

FIG. 261 Stitching Type EFe-1

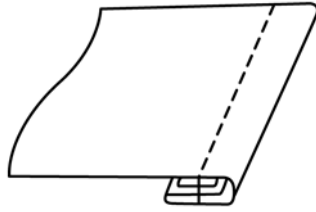

NOTE 1—This type of stitching shall be produced by turning and folding the edge of the material, inserting a strip between the fold and the body of the material and stitching with one or more rows of stitches.

FIG. 262 Stitching Type EFF-1

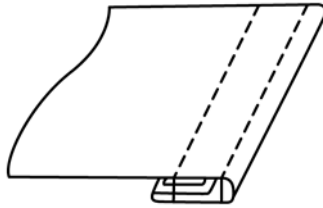

NOTE 1—This type of stitching shall be produced by turning and folding the edge of the material, inserting a strip between the fold and the body of the material, and stitching with two rows of stitches. The strip shall be secured by one or more rows of stitches as specified.

FIG. 263 Stitching Type Efg-2

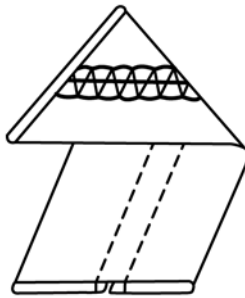

NOTE 1—This type of stitching shall be produced by turning the edges of a strip of material, bringing the edges together, and stitching the butted edges with a row of stitches extending across and covering the edges of the material.

FIG. 264 Stitching Type Efh-1

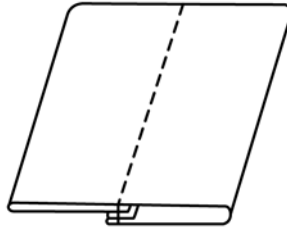

Stitching type EFj-1

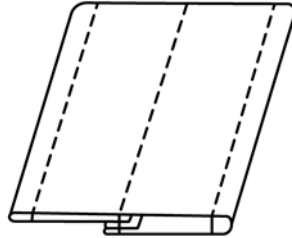

Stitching type EFj-3

NOTE 1—This type of stitching shall be produced by folding a strip of material, overlapping the edges, turning the edge of the under ply, and stitching through all the plies with one row of stitches (stitching type EFj-1). One row of stitches shall be placed at each folded edge to form stitching type EFj-3.

FIG. 265 Stitching Type EFj

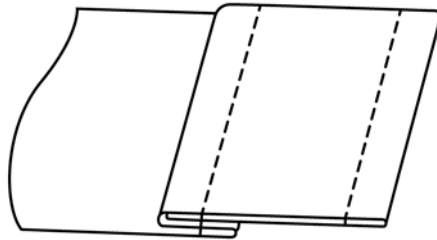

Stitching type EFk-2

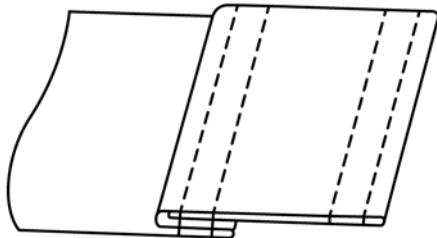

Stitching type EFk-4

NOTE 1—This type of stitching shall be formed by folding the material in an "S" fold, turning the free edge back into the top of the "S" and stitching with one or more rows of stitches through each side of the fold.

FIG. 266 Stitching Type EFk

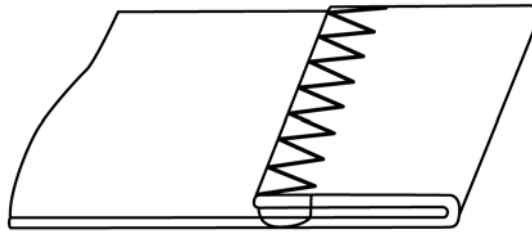

NOTE 1—This type of stitching shall be produced by turning the edge of the material and stitching it to the body material with one row of stitches. The stitches shall overedge the turned edge and the needle shall only partially penetrate the body material so that the stitches do not show on the outer face of the material.

FIG. 267 Stitching Type Efl-1

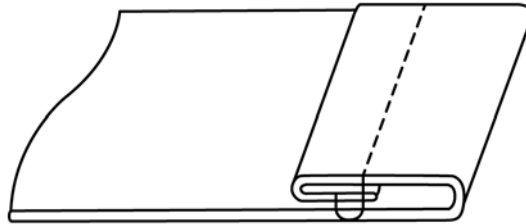

NOTE 1—This type of stitching shall be produced by turning the edge of the material, folding it back over the body material, and joining the turned and folded portion to the body material with one row of stitches. The needle shall only partially penetrate the body material so that the stitches do not show on the out face of the material.

FIG. 268 Stitching Type Efm-1

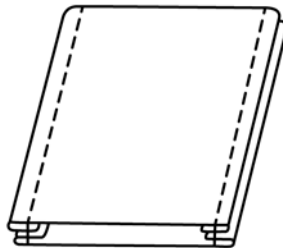

Stitching type EFn-2

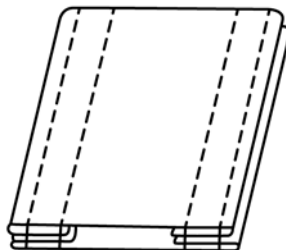

Stitching type EFn-4

NOTE 1—This type of stitching shall be produced by turning the edges of two strips of material and joining the edges so turned by two or four rows of stitches.

FIG. 269 Stitching Type Efn

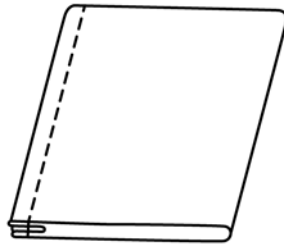

Stitching type EFp-1

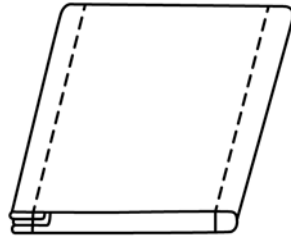

Stitching type EFp-2

NOTE 1—This type of stitching shall be produced by turning a strip of material, folding the edges inwardly and joining with one or two rows of stitches.

FIG. 270 Stitching Type Efp

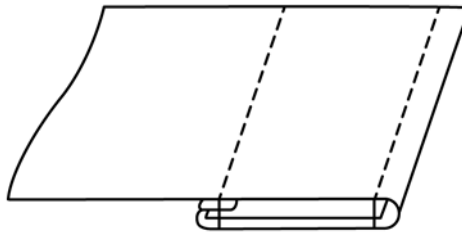

NOTE 1—This type of stitching shall be produced by turning and folding the edge of the material around a strip and stitching with two or four rows of stitches. The strip shall be secured by all the rows of stitches.

FIG. 271 Stitching Type EFq-2

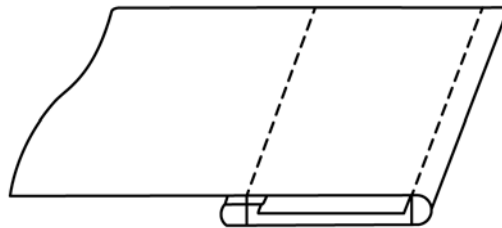

NOTE 1—This type of stitching shall be produced by turning and folding the edge of the material around a strip and stitching the material with two rows of stitches. The strip shall not be caught in either of the rows of stitches.

FIG. 272 Stitching Type EFr-2

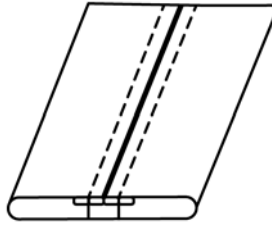

NOTE 1—This type of stitching shall be produced by turning both edges of a strip of material upward and then downward, abutting the folded edges, and stitching with two rows of stitches.

FIG. 273 Stitching Type EFs-2

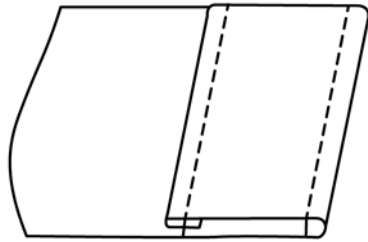

Stitching type Eft-2

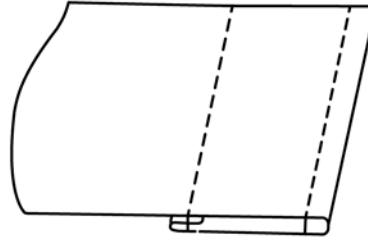

Stitching type Eft-2
(Inverted)

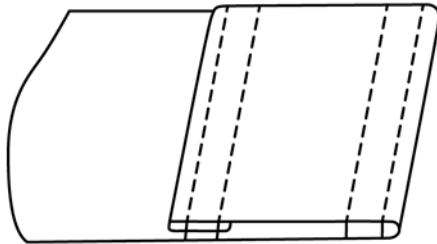

Stitching type Eft-4

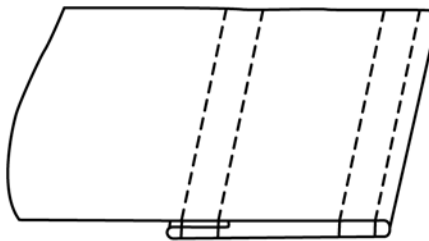

Stitching type Eft-4
(Inverted)

NOTE 1—This type of stitching shall be produced by turning the edge of the material, folding it back over the body material and stitching with two or more rows of stitches.

FIG. 274 Stitching Type Eft

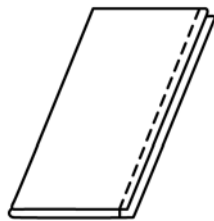

(a)



(b)

NOTE 1—This type of stitching shall be formed by folding a piece of material with the face inside and stitching along the edge with one row of stitches. After stitching, the cylinder thus made is turned inside out to place the face of the material on the outside.

FIG. 275 Stitching Type Efu-1

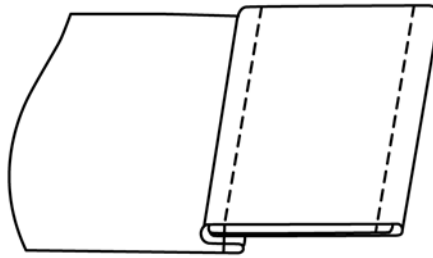

Stitching type EFv-2

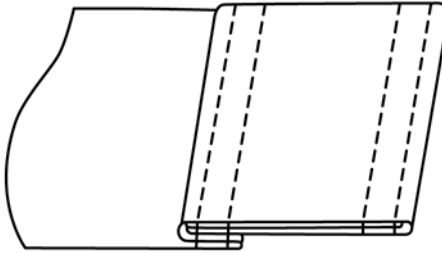

Stitching type EFv-4

NOTE 1—This type of stitching shall be formed by folding the material, inserting an interlining strip, and stitching with two or four rows of stitches.

FIG. 276 Stitching Type EFv

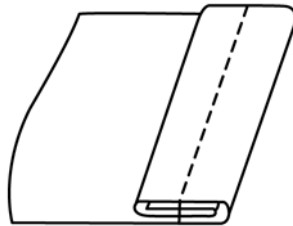

NOTE 1—This type of stitching shall be produced by turning the edge back over the body material and in under that fold, and stitching the turned and folded portion to the body of the material with one or more rows of stitches.

FIG. 277 Stitching Type EFw-1

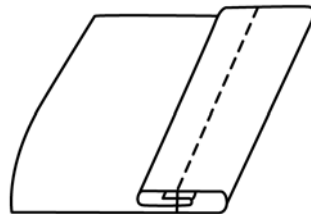

NOTE 1—This type of stitching shall be produced by turning the edge back over the body material and in under that fold a specified distance, and stitching turned and folded portion to the body of the material with one or more rows of stitches.

FIG. 278 Stitching Type EFx-1

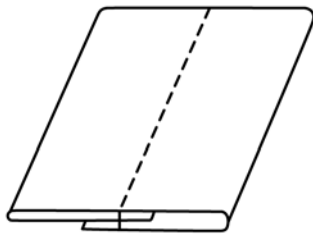

Stitching type EFy-1

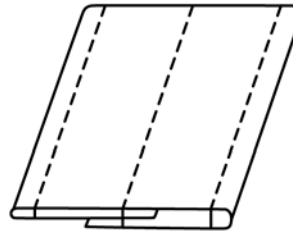

Stitching type EFy-3

NOTE 1—This type of stitching shall be produced by folding a strip of material, overlapping the edges, and stitching through all plies with one row of stitches to form stitching type EFy-1. One row of stitches shall be placed at each folded edge to form stitching type EFy-3.

FIG. 279 Stitching Type EFy

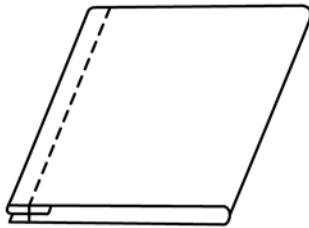

Stitching type EFz-1

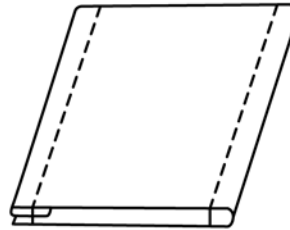

Stitching type EFz-2

NOTE 1—This type of stitching shall be produced by turning a strip of material, folding one edge inwardly and joining with one or two rows of stitches.

FIG. 280 Stitching Type E fz

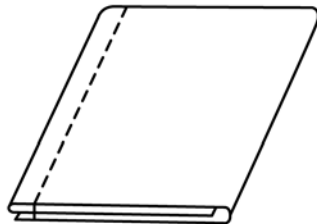

Stitching type EFaa-1

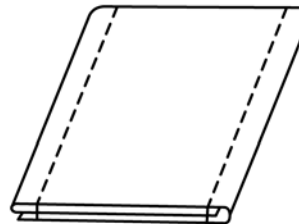

Stitching type EFaa-2

NOTE 1—This type of stitching shall be produced by folding a strip of material to form three plies and joining with one or two rows of stitches.

FIG. 281 Stitching Type Efaa

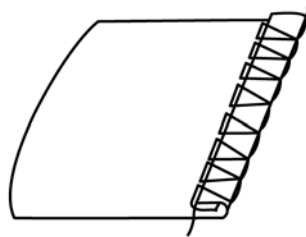

NOTE 1—This type of stitching shall be produced by turning the edge of the material, folding it back over the body of the material, and placing one or more rows of stitches over the edge of the material.

FIG. 282 Stitching Type EFab

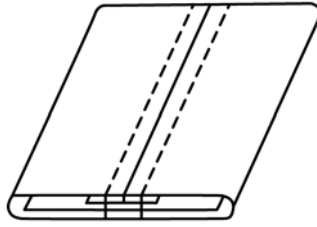

NOTE 1—This type of stitching shall be produced by turning both edges of a strip of material around a reinforcing strip, turning the edges inward, abutting the folded edges and stitching with two rows of stitches.

FIG. 283 Stitching Type EFac-2

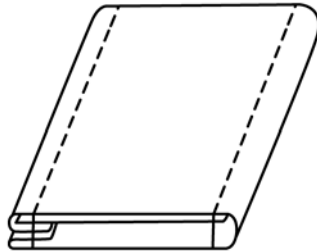

NOTE 1—This type of stitching shall be produced by turning a strip of material, inserting a reinforcing strip, folding the edges of the material inwardly with one edge folded around the strip, and stitching with two or more rows of stitches. The strip shall be secured by all the rows of stitches.

FIG. 284 Stitching Type EFad-2

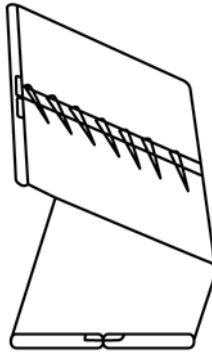

NOTE 1—This type of stitching shall be produced by turning both edges of a strip of material upward and then downward, abutting the folded edges, and stitching with a row of stitches extending across and covering the abutted edges of the material. The needle shall penetrate only partially the under ply so that the stitches do not show on the outer surface of the material.

FIG. 285 Stitching Type EFae-1

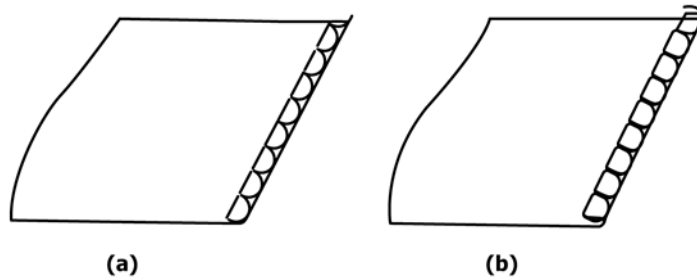

NOTE 1—This type of stitching shall be produced by:
 (a) placing a row of stitches over the edge of the material, and
 (b) turning the overedged edge and placing one or more rows of stitches over the turned edge of the material.

FIG. 286 Stitching Type EFaf-2

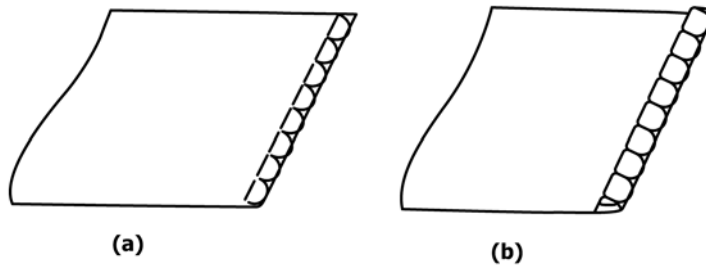

NOTE 1—This type of stitching shall be produced by:
(a) placing a row of stitches over the edge of the material, and
(b) turning and folding the overedged edge and placing one or more rows of stitches over the turned edge of the material.

FIG. 287 Stitching Type EFag-2

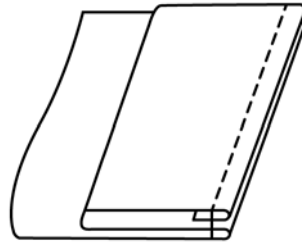

NOTE 1—This type of stitching shall be produced by folding the edge of the material in an “S” fold with the raw edge turned under to form a finished edge, and stitching through the two folds with one row of stitches.

FIG. 288 Stitching Type EFah-1









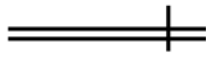
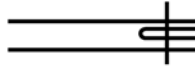
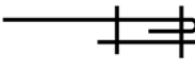
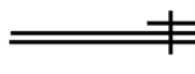
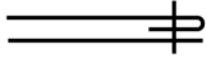
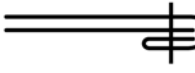
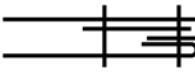

 SSa	 SSk	 SSr	 SSab
 SSb	 SSl	 SSu	 SSac
 SSd	 SSm	 SSv	 SSad
 SSn	 SSw	 SSae	 SSa
 SSe	 SSp	 SSx	 SSaf
 SSf	 SSq	 SSy	 SSag
 SSh	 SSr	 SSz	 SSah
 SSj	 SSs	 SSaa	 SSaj

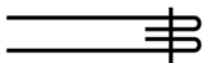
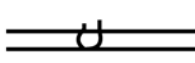
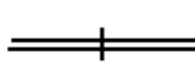
FIG. 289 Seam Type SS (Superimposed)

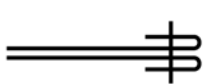
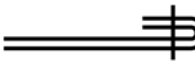
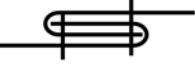
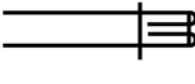
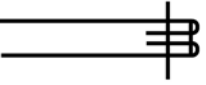
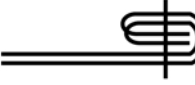

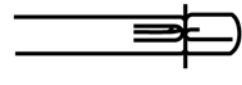
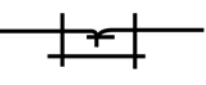
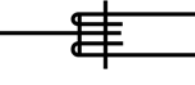



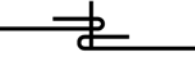
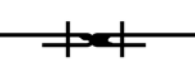
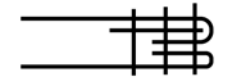
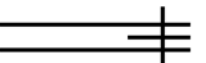
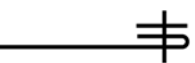
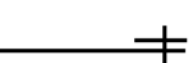
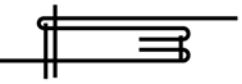



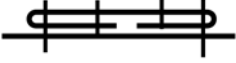





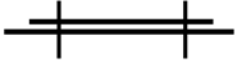
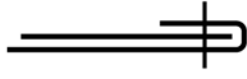

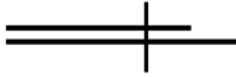
 SSak	 SSas	 SSba	
 SSal	 SSat	 SSbb	
 SSam	 SSau	 SSbc	
	 SSav	 SSbd	
 SSao	 SSaw	 SSbe	
 SSap	 SSax	 SSbf	
 SSaq	 SSay	 SSbg	
 SSar	 SSaz	 SSbh	

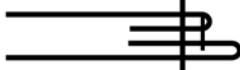
FIG. 290 Seam Type SS (Superimposed) (Continued)





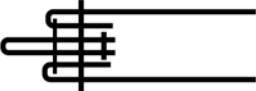
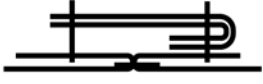

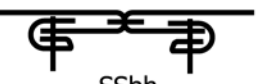





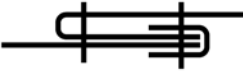



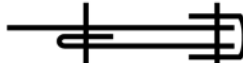

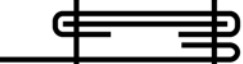

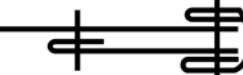

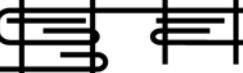







 LSa	 LSk	 LSt	 LSab
 LSb	 LSI	 LSu	 LSac
 LSc	 LSm	 LSv	 LSad
 LSd	 LSn	 LSw	 LSae
 LSe	 LSp	 LSx	 LSaf
 LSf	 LSq	 LSy	 LSag
 LSg	 LSr	 LSz	 LSah
 LSj	 LSS	 LSaa	 LSaj

FIG. 291 Seam Type LS (Lapped)











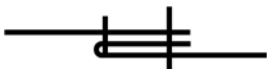
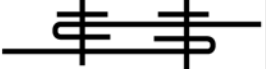
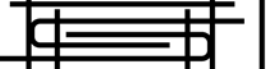

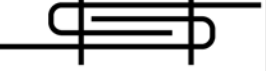







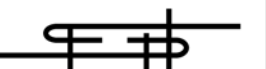

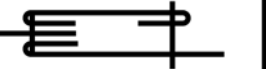

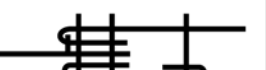
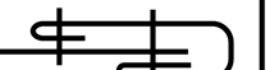
 LSak	 LSat	 LSbb	 LSbk
 LSal	 LSau	 LSbc	 LSbl
 LSam	 LSav	 LSbd	 LSbm
 LSan	 LSaw	 LSbe	 LSbn
 LSap	 LSax	 LSbf	 LSbo
 LSaq	 LSay	 LSbg	 LSbp
 LSar	 LSaz	 LSbh	 LSbq
 LSas	 LSba	 LSbj	 LSbr

FIG. 292 Seam Type LS (Lapped) (Continued)

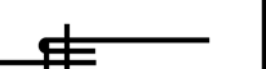

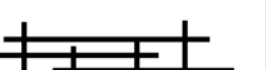



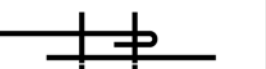
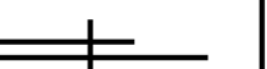
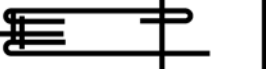





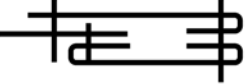

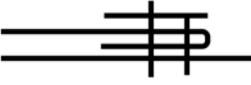

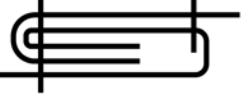
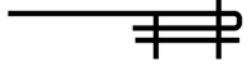

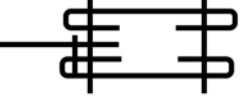
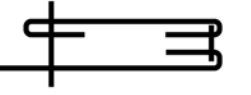

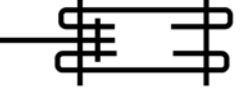
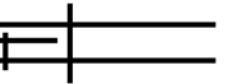
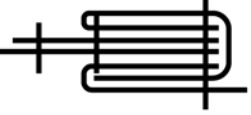

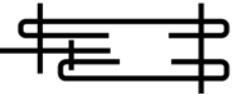
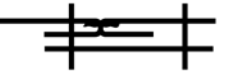
 LSbs	 LSca	 LScj	 LScr
 LSbt	 LSab	 LSck	 LScs
 LSbu	 LScc	 LScI	 LScT
 LSbv	 LScd	 LScm	 LScu
 LSbw	 LScE	 LScn	 LScv
 LSbx	 LScf	 LScO	 LScw
 LSby	 LScg	 LScp	 LScx
 LSbz	 LSch	 LScq	 LScy

FIG. 293 Seam Type LS (Lapped) (Continued)

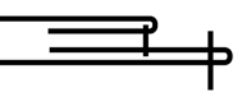

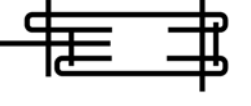
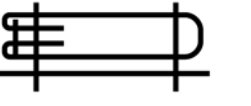
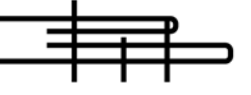

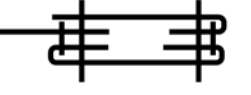
 <p>LSbz</p>			
 <p>LSda</p>			
 <p>LSdb</p>			
 <p>LSdc</p>			
 <p>LSdd</p>			

FIG. 294 Seam Type LS (Lapped) (Continued)





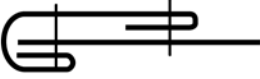

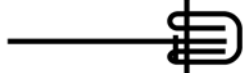
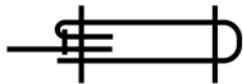
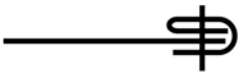
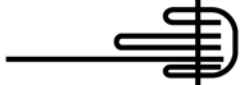

 <p>BSa</p>	 <p>BSj</p>	 <p>BSr</p>	
 <p>BSb</p>	 <p>BSk</p>	 <p>BSS</p>	
 <p>BSc</p>	 <p>BSI</p>		
 <p>BSd</p>	 <p>BSm</p>		
 <p>BSd</p>	 <p>BSn</p>		
 <p>BSf</p>	 <p>BSo</p>		
 <p>BSg</p>	 <p>BSp</p>		
 <p>BSh</p>	 <p>BSq</p>		

FIG. 295 Seam Type BS (Bound)

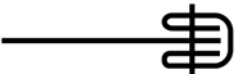

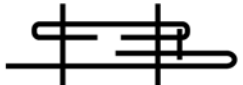
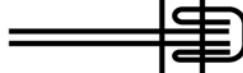

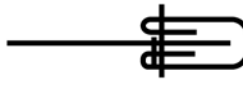
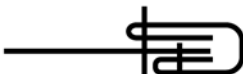
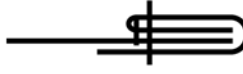

 <p>FSa</p>	 <p>FSe</p>		
 <p>FSb</p>	 <p>FSf</p>		
 <p>FSc</p>			
 <p>FSd</p>			

FIG. 296 Seam Type FS (Flat)







 <p>OSa</p>	 <p>OSe</p>		
 <p>OSb</p>	 <p>OSf</p>		
 <p>OSc</p>	 <p>OSg</p>		
 <p>OSd</p>	 <p>OSh</p>		

FIG. 297 Seam Type OS (Ornamental)







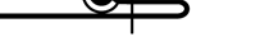



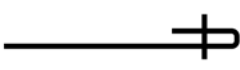

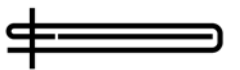
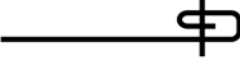

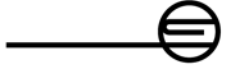

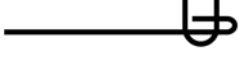

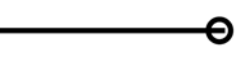
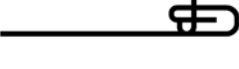
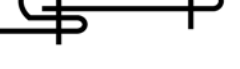
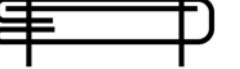
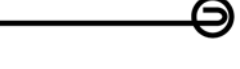
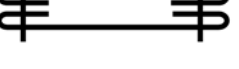

 EFa	 EFj	 EFs	 EFaa
 EFb	 EFk	 EFt	 EFab
 EFc	 EFI	 EFu	 EFac
 EFd	 EFn	 EFv	 EFad
 EFe	 EFn	 EFw	 EFae
 EFF	 Efp	 EFx	 EFaf
 EFG	 EFq	 Efy	 EFag
 EFh	 EFr	 EFz	 EFah

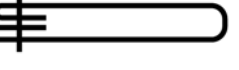
FIG. 298 Seam Type EF (Edge Finishing)

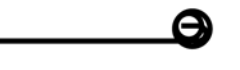
ANNEX
(Mandatory Information)
A1. SEAM ASSEMBLY RECOMMENDATIONS
A1.1 Seam Assembly Recommendations

Seam type	Operation	Types of standard stitches suitable
Superimposed seams		
SSa-1	Seaming (bags, jute, cotton) Basting Seaming (straight) Seaming (zizag) Seaming (overedge) Seaming (using waxed thread) Seaming and serging	101, 104, 301, 401 101 301, 401 304, 404 501 to 513 101, 201, 301 301, 401, 501 to 507, 602, 515 to 519
SSa-2		
SSb-1 and SSb-2	Seaming (straight) Seaming (where similar stitch is essential on both surfaces).	301, 401, 302, 402 301
SSc-1 and SSc-2	Seaming	301, 401, 302, 402
SSd-1	Seaming	301, 401
SSe-2 and SSe-3	Seaming and edge finishing Making cuffs, collars, etc., and edge stitching on coats and shoes.	301, 401, 302, 402
SSf-3	Taping or staying	301, 401
SSh-2	Cover seaming	302, 402, 406
SSj-1	Seaming	201, 301, 401
SSk-1	Seaming and cording	201, 301, 401
SSL-1	Seaming	201, 301, 401
SSm-1	Seaming or felling, where a blind stitch is required Padding lapels, felling tapes, etc.	103 103
SSn-1	Seaming	101, 301, 401
SSp-1	Seaming	301, 401
SSq-2 and SSq-3	Seaming	301, 401, 302, 402
SSr-1	Seaming	301, 401
SSs-1 and SSs-2	Seaming and staying	301, 401
SSt-2 to SSt-4	Seaming and taping	301, 401
SSu-2 to SSu-4	Attaching elastic	301, 401
SSu-2	Making pocket jettings	301
SSv-1 to SSv-3	Quilting	301, 401
SSw-2	Seaming	301, 401
SSx-2	Seaming (crotch pieces and linings to trousers)	301, 401
SSy-2	Seaming	301, 401
SSz-3	Seaming	301, 401
SSaa-1	Taping (coat fronts and armholes)	301
SSab-1	Taping (coat fronts and armholes)	301
SSac-3	Taping (crotch seams on trousers)	301
SSad-3	Seaming and staying	301, 401
SSae-2 and SSae-3	Seaming	301, 401
SSaf-2	Seaming and staying	301, 401
SSag-3	Seaming and staying	301, 401
SSah-3 and SSah-4	Seaming	301, 401

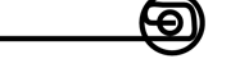
Seam type	Operation	Types of standard stitches suitable
<u>Superimposed seams cont.</u>		
SSaj-3	Seaming	301, 401
SSak-1	Attaching slide fasteners	301, 401
SSal-2	Attaching slide fasteners	301, 401
SSam-2	Seaming	301, 401
SSao-2	Seaming	301, 401
SSap-3	Seaming	301, 401
SSaq-2	Seaming	301, 401
SSar-3	Attaching end of left fly lining to crotch seam	301, 401
SSas-4	Attaching buttonhole strips	301, 401
SSat-2	Attaching buttonhole strips	301, 401
SSau-2	Staying	301, 401
SSav-2	Seaming and welting	301, 401
SSaw-2	Seaming and welting	301, 401, 504
Sax-2	Seaming and welting	301, 401, 504
SSay-2	Making waistbands	301, 401
SSaz-1	Seaming neckties	104
SSba-3	Book seaming	103 and 301 or 401
SSbb-3	Seaming and staying	301, 401
SSbc-1	Attaching interlining to cuff	103, 306
SSbd-1	Seaming	301, 401
SSbe-2	Seaming and edge finishing	301, 306, 401
SSbf-3	Seaming and welting	301, 401
SSbg-3	Seaming and welting	301, 401
SSbh-3	Seaming	301, 401
<u>Lapped seams</u>		
LSa-1	Seaming knitted materials or underwear and similar garments	602, 603, 604, 605
LSa-1 and LSa-2	Seaming	301, 401, 402, 406, 407
	Seaming (using waxed thread)	101, 201, 301
LSb-1 and LSb-2	Seaming	301, 401, 402, 406
LSc-1 and LSc-4	Seaming	301, 401
LSd-1 to LSd-3	Attaching pieces to body of material	301, 304, 401
LSe-1 to LSe-3	Seaming	301, 401
LSf-1 and LSf-2	Seaming	301, 401
LSg-2 to LSg-4	Facing (center plaits, stays, etc.)	301, 401
LSj-2 and LSj-4	Facing (center plaits, stays, etc.)	301, 401
LSk-2 and LSk-4	Facing (center plaits, stays, etc.)	301, 401
LSI-2 and LSI-4	Facing and seaming (center plaits, stays, etc.)	301, 401
LSm-2 and LSM-4	Facing (center plaits, stays, etc.)	101, 301, 401
LSn-1	Facing (center plaits, stays, etc.)	301, 401
LSp-2 and LSp-4	Joining with overlapping strip	301, 401
LSq-2 and LSq-3	Seaming	201, 301, 401
LSr-2	Seaming	301, 401
LSs-2	Seaming	301, 401
LSt-2	Seaming	301, 401
LSu-2	Seaming	301, 401
LSv-2	Facing and staying	301, 401

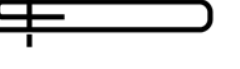
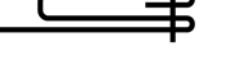
Seam type	Operation	Types of standard stitches suitable
<u>Lapped seams. cont.</u>		
LSw-4	Joining band (plain, elastic, etc.)	301, 401
LSx-2 and LSx-3	Seaming	301, 401
LSy-2 and LSy-3	Seaming	301, 401
LSz-3 and LSz-4	Seaming	301, 401
LSaa-3	Seaming	301, 401
LSab-3 and LSab-4	Banding	301, 401
LSac-2	Facing and binding	301, 401
LSad-2	Facing and binding	301, 401
LSae-1	Undersewing cushion	301, 401
LSaf-2	Staying automobile quarters	301, 401
LSag-2	Staying automobile quarters	301, 401
LSah-1	Seaming	301, 401
LSaj-1	Seaming	301, 401
LSak-2	Seaming	301, 401
LSal-2 and LSal-4	Facing (center plaits, stays, etc.)	301, 401
LSam-2 and LSam-4	Facing (center plaits, stays, etc.)	301, 401
LSan-2 and LSan-4	Facing (center plaits, stays, etc.)	301, 401
LSap-1	Finishing	301, 401
LSaq-1	Finishing	301, 401
LSar-2 to LSar-4	Facing and seaming	301, 401
LSas-2	Seaming and gathering	301, 401
LSat-2	Seaming and staying	301, 401
LSau-2 to LSau-4	Seaming	301, 401
LSav-4	Seaming and reinforcing	301, 401
LSaw-3	Seaming	301, 401
LSax-4	Seaming	301, 401
LSay-4	Sewing-on band with elastic	301, 401
LSaz-4	Seaming and staying	301, 401
LSba-2	Seaming	301, 401
LSbb-4	Seaming and staying	101, 301, 401
LSbc-2 to LSbc-4	Facing	301, 401
LSbd-2	Seaming	301, 401
LSbe-2	Seaming	301, 401
LSbf-2 to LSbf-4	Binding (center plait)	301, 401
LSbg-1	Seaming	301, 401
LSbh-1 and LSbh-2	Binding, inserting tape between binding and body material.	301, 401
LSbj-1	Attaching pieces to body material	301, 401
LSbk-2	Attaching pieces to body material	301, 401
LSbl-2	Attaching pocket flaps and belt loops	301, 401
LSbm-3 and LSbm-4	Seaming	301, 401
LSbn-2	Seaming	301, 401
LSbo-3	Seaming	301, 401
LSbp-2	Joining yoke to shirt	301, 401
LSbq-2	Joining yoke to shirt in loosely woven material	301, 401
LSbr-3	Seaming	301, 401
LSbs-1	Attaching slide fasteners	301, 401
LSbt-2	Attaching slide fasteners	301, 401
LSbu-2	Attaching slide fasteners	301, 401

Seam type	Operation	Types of standard stitches suitable
<u>Lapped seams. cont.</u>		
LSbv-3	Attaching slide fasteners	301, 401
LSbw-3	Seaming and binding	301, 401
LSbx-2	Forming welt on set-in pockets	301, 401
LSby-2	Forming welt on set-in pockets	301, 401
LSbz-2	Forming pocket welts	301, 401
LSca-2	Forming pocket welts	301, 401
LScb-2	Top edge of hip pocket with a stay and facing	301, 401
LScc-2	Top edge of hip pocket	301, 401
LScd-3	Top edge of hip pocket	301, 401
LSce-2	Forming welt on bottom edge of set-in hip pockets	301, 401
LScf-2	Attaching cuffs, waistbands or collars	301, 401
LScg-2	Attaching cuffs, waistbands or collars	301, 401
LSch-2	Attaching cuffs, waistbands or collars	301, 401
LScj-3	Attaching cuffs, waistbands or collars	301, 401
LSck-3	Attaching cuffs, waistbands or collars	301, 401
LScl-3	Attaching cuffs, waistbands or collars	301, 401
LScm-3	Attaching cuffs, waistbands or collars	301, 401
LScn-3	Attaching cuffs, waistbands or collars	301, 401
LSco-4	Attaching cuffs, waistbands or collars	301, 401
LScp-4	Attaching cuffs, waistbands or collars	301, 401
LScq-4	Attaching cuffs, waistbands or collars	301, 401
LScr-4	Attaching cuffs, waistbands or collars	301, 401
LScs-3	Attaching left fly to trouser fronts	301, 401
LSct-2	Attaching waistband linings	301, 401
LScu-2	Finishing bottoms of caps	301, 401
LScv-3	Seaming curtains on waistbands	301, 401
LScw-3	Making sewn-on belts or bands	301, 401
LScx-3	Making sewn-on belts or bands	301, 401
LScy-3	Seaming and staying	301, 401
LScz-2	Seaming	301, 401
LSda-2	Making flag headings	301, 401
LSdb-2	Facing	301, 401
LSdc-3	Trouser crotch seam	301, 401
LSdd-2	Cut-on shirt front	301, 401
<u>Bound seams</u>		
BSa-1 and BSa-2	Binding, bound seaming	301, 401, 304, 404, 406
BSb-1 and BSb-2	Binding, bound seaming	301, 401, 304, 404
BSc-1 and BSc-2	Binding, bound seaming	301, 401, 304, 404
BSd-2	Seaming and binding	301, 401
BSe-2	Seaming and binding	301, 401
BSf-2	Seaming and binding	301, 401
BSg-2	Seaming and binding	301, 401
BSh-3	Seaming and binding	301, 401
BSj-2	Binding, bound seaming	301, 304, 401, 404, 406
BSk-1	Binding and welting	301, 401
BSl-4	Binding flag headings	301, 401
BSm-3	Facing pockets	301, 401

Seam type	Operation	Types of standard stitches suitable
<u>Bound seams. cont.</u>		
BSn-4	Binding flag headings	301, 401
BSo-2	Binding, bound seaming	301, 304, 401, 404, 406
BSp-2	Making pocket welts	301, 401
BSq-2	Seaming and binding	301, 401
BSr-2 and BSr-4	Seaming and binding	301, 401
BSS-2	Binding flag headings	301, 401
<u>Flat seams</u>		
FSa-1	Seaming	304, 404, 606, 607
	Attaching collars, cuffs, borders, etc. to knitted articles	602, 603, 606
FSb-1	Attaching edging, lace, etc.	601, 602, 603
	Seaming	304, 602, 603, 606
FSc-1	Seaming	304, 404
FSd-3	Seaming and staying	304, 404
FSe-1	Seaming and staying	304, 404
FSf-1	Hosiery toe closing	521
	Seaming fur pelts, or seaming with over edge stitching where a flat butted seam is desired	501 through 505
<u>Ornamental stitching</u>		
OSa-1 to OSa-3	Ornamental	101, 102, 104, 201, 203, 204 301, 302, 303, 304, 305, 306, 307 309, 310, 311, 312, 402, 403, 404 405, 406
OSb-1	Cording	102, 302, 402, 406
OSc-1	Cording	102, 302, 402, 406
OSd-2 and OSd-3	Cording	101, 301, 401
OSe-1	Tucking or plaiting	101, 301, 401
OSf-1	Tucking and mock seaming	101, 301, 401
OSg-3	Making box or inverted plait	301, 401
OSh-3	Welting	301, 401
<u>Edge finishing</u>		
EFa-1 and EFa-2	Hemming (one fold)	101, 102, 301, 302, 401, 402, 406
EFb-1 and EFb-2	Hemming (two folds)	101, 301, 401, 402, 406
EFc-1	Blind hemming (woven)	301
	Blind hemming (knit)	301, 401, 502, 503, 505
EFd-1	Edge finishing (serging)	502, 503, 504, 505
	Ornamental edge finishing	304, 502, 503, 504, 505, 601, 603, 604, 605, 607
EFe-1	Ornamental edge finishing (zigzag)	304, 404
EFF-1	Hemming with elastic tape	101, 301, 401
EFg-2	Hemming with elastic tape	101, 301, 401
EFh-1	Making loops or straps	406
EFj-1 and EFj-3	Making straps	301, 401
	Making straps (using waxed thread)	101, 301
EFk-2 and EFk-4	Cut-on center plait (shirt fronts)	301, 401
EFl-1	Blind hemming	103, 301, 306, 401, 502, 503

Seam type	Operation	Types of standard stitches suitable
<u>Edge finishing. cont.</u>		
EFm-1	Blind hemming	103, 301, 306, 401, 502, 503
EFn-2 and EFn-4	Making straps or loops	301, 401
EFp-1 and EFp-2	Making straps or loops	301, 401
EFq-2	Inserting elastic in hems	301, 401
EFr-2	Inserting elastic in hems	301, 401
EFs-2	Making straps or loops	301, 401
EFT-2 and EFT-4	Hemming shirt fronts	301, 401
EFu-1	Making drawstrings or loops	301, 401
EFv-2 and EFv-4	Cut-on center plait (shirt fronts)	301, 401
EFw-1	Hemming (three folds)	101, 301, 401, 402, 406
EFx-1	Hemming	101, 301, 401, 402, 406
EFy-1 and EFy-3	Making straps or loops	301, 401, 406
EFz-1 and EFz-2	Making straps or loops	301, 401, 406
EFaa-1 and EFaa-2	Making straps or loops	301, 401, 406
EFab-1	Hemming	502, 503, 504, 505
EFac-2	Making straps or loops	301, 401
EFad-2	Making straps or loops	301, 401
EFae-2	Making straps or loops	103
EFaf-2	Edge finishing	501, 502, 503, 504, 505
EFag-2	Edge finishing	501, 502, 503, 504, 505
EFah-1	Hemming	301, 401

APPENDIX

X1. SEWN APPLICATIONS FOR BUTTONS / SNAPS / HOOK AND EYE ATTACHMENTS, BUTTONHOLE STITCHING, BARTACK / REINFORCEMENT STITCHING, TACKINGS, SPECIALTY STITCHING / SEAMS AND GUIDE TO COUNT STITCHES PER INCH

X1.1 Buttonhole Stitching (see Figs. X1.1-X1.10)

X1.1.1.1 *Notes:*

X1.1.1.1.1 Buttonholes should be large enough to easily accommodate the pass-through of the button and then freely encircle the stitching, holding the button so that the sides of the buttonhole will close neatly together.

X1.1.1.2 *Buttonhole Types* (see **Table X1.1**).

X1.1.1.3 Stitching available in style of regular Purl stitching (fine appearance) over a hard finish reinforcement cord or that of heavily beaded Purl stitching (course appearance) over a soft reinforcement cord (buttonhole gimp). Purl stitching is generally formed with the needle thread passing through the center of the buttonhole and bobbin thread entangling it from the right

and left. Whip stitching is generally used in knit goods and is a light zigzag stitching with needle thread on top and bobbin thread on underside.

X1.1.1.4 All buttonholes require either flat square tacking, taper and tacking or with fly-bar tacking at ends.

X1.1.1.5 Buttonhole gimp, usually Tex 270, used as a stuffer for raised effect and general reinforcement. Flat gimp buttonholes generally referred to as buttonhole sewn over twice with no gimp can be used for knits.

X1.1.1.6 Straight design is prevalent in shirts and blouses.

X1.1.1.7 Imitation design is simply zig-zag stitch.

X1.1.1.8 Bound design requires specialized equipment. No stitching is exhibited.

X1.2 Buttons, Snaps and Hook and Eye Stitch Attachment PatternsX1.2 (see Figs. X1.11- X1.25)

X1.2.1 *Notes:*

X1.2.1.1 Typical button attachment includes stitch density of 6, 8, 12, 16, 24 or 32 stitches.

X1.2.1.2 Holding strength and fullness of stitches is dependent upon stitch density and thread size. The higher tex size of sewing thread used, the greater the fullness of stitches and greater the holding strength.

TABLE X1.1 Buttonhole Types

Buttonhole Type	Cut-After	Cut-Before
Length Range	½ to 2 in.	½ to 1 ¾ in.
Use	All types of woven and knit fabrics	Fabrics that are substantially firm and outerwear
Finish Appearance	Uneven and unfinished	Clean, even, and smooth

X1.2.1.3 Button attachment stitch construction includes starting stitch (tie stitch), parallel stitches (sewn wrapped stitching), crossover stitch (optional), neck wrapped stitching (optional), fastening stitching and final tying stitch (ending stitch).

X1.2.1.4 Extremely small buttons range from (insert – ligne size for each size: petite, small, medium, large, plus) 7-9 mm (9/32–11/32 in.), small from 10-12 mm (3/8–15/32 in.), medium from 13-20 mm (1/2–25/32 in.) and large from 21-28 mm (greater than 13/16 in.).

X1.2.1.5 Some sewn wrapped equipment offers an adjustable distance between the cloth and button from 9-18 mm; otherwise, button is generally non-adjustable at a distance 7.5 mm above fabric. Neck wrapping process is 5 mm maximum wrap, thus leaving rigid stand-up button.

X1.2.1.6 Typical button machine can change from 2 to 4 hole button with change in stitch/inch, stitch length and number of stitches.

X1.2.1.7 For appearance sake the ‘two hole’ button can be specified horizontal or vertical.

X1.2.1.8 Four hole buttons can be specified, for appearance sake, as not having a crossover stitch: “Parallel”; “Triangle”; “Square L”; “Trident”; “X-Pattern”.

X1.2.1.9 Four hole buttons can be specified for appearance sake as having one crossover stitch: “C” style; “S” Style; “Z” Style; “X” Style.

X1.3 Reinforcement Stitching and Tacking Seams

X1.3 (see Figs. X1.26-X1.41)

X1.3.1 Notes:

X1.3.1.1 Bartacks are typically used for reinforcements at either the beginning or ending of stitch lines used to secure pockets, cuffs, side seams, belt loops, collars, etc. A bartack can also add additional strength to any backstitched seams.

X1.3.1.2 Backstitching requires a minimum of 3 stitches to prevent runback and impart strength to prevent peeling.

X1.3.1.3 “W” stitching, specify number of points and width of throw.

X1.3.1.4 Throw of bartacks refers to width of tacking.

X1.3.1.5 Backstitch over beginning of initial stitch line to maximize strength of all reinforcements that are made using “W”, “X”, “Z”, and “Box X” patterns.

X1.3.1.6 Box-X imparts highest strength.

X1.3.1.7 Total no. of stitches counted from point to point.

X1.3.1.8 Maintain “X”, “Box-X”, “W” and “Z” reinforcement stitching to minimum 1/8 in. from sewn material edges. Run-offs degrade strength.

X1.3.1.9 Any stitching along single layer non-seared edge material may unravel over time.

X1.4 Guide to Count Bartacking and Zig-Zag Stitches/InchX1.4 (see Figs. X1.42-X1.46)

X1.4.1 For the sake of this model, a simple formula of counting the number points on one side (10), times two (20), adding 10 stitches for initial horizontal stitch line and then 6 more for backtacking was used. The difficult part in counting finished bartacks is to distinguish counting the points in the zig-zag stitch line without counting the bartack stitches. The stitch formation at far left contains both a starter and closing stitch thus counts as a double stitch.

X1.4.2 Typical bartack stitches consist of 14, 21, 28, 36, 42, 56 & 64 stitches.

X1.5 Specialty Stitching and SeamX1.5 (see Figs. X1.47-X1.52)

X1.5.1 Notes:

X1.5.1.1 Eyelets use 401 chain stitch. Size is diameter of inner-hole.

X1.5.1.2 Scallop stitching is curved 24 stitch 2-point zig-zag. Scallop also refers to zig-zag or straight stitching sewn over gimp filler cord for decorative embroidery and ric-rac effect.

X1.5.1.3 Faggoting and ladderstitching is open ornamental stitching attaching edges of two pattern pieces.

X1.5.1.4 Striping is raised two thread chain stitching for backs of gloves, stockings, socks, etc.

REFERENCED FIGURES



FIG. X1.1 Eyelet-End with Fly Bar



FIG. X1.2 Eyelet-End, Straight Finish



FIG. X1.3 No-Eye Lapel



FIG. X1.4 No-Eye with Fly Bar

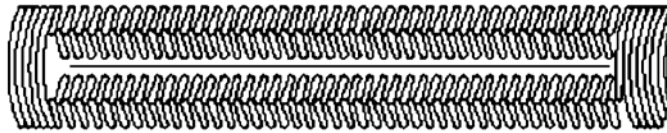

FIG. X1.5 Straight Design

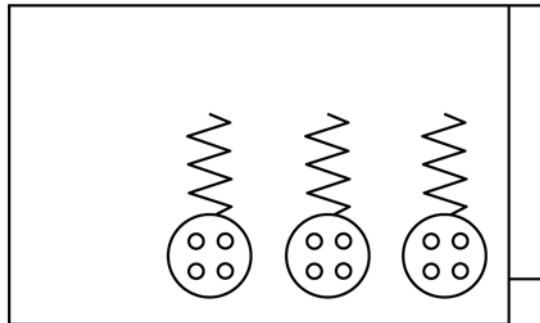

FIG. X1.6 Imitation Design

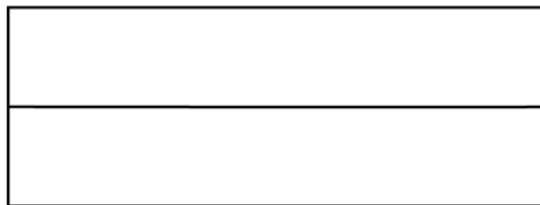

FIG. X1.7 Bound Design

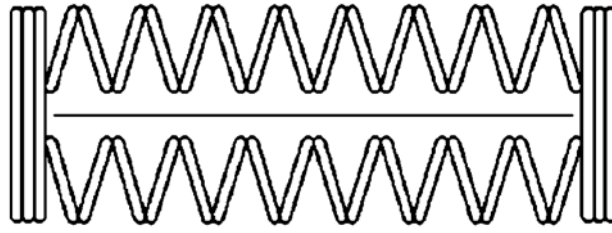

FIG. X1.8 Whip Stitching

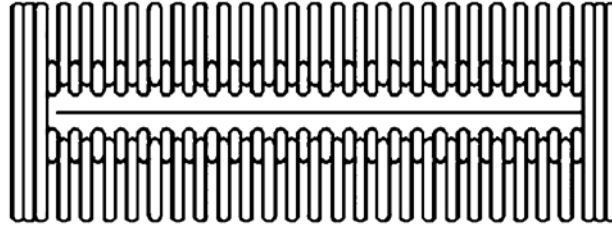

FIG. X1.9 Purl Stitching

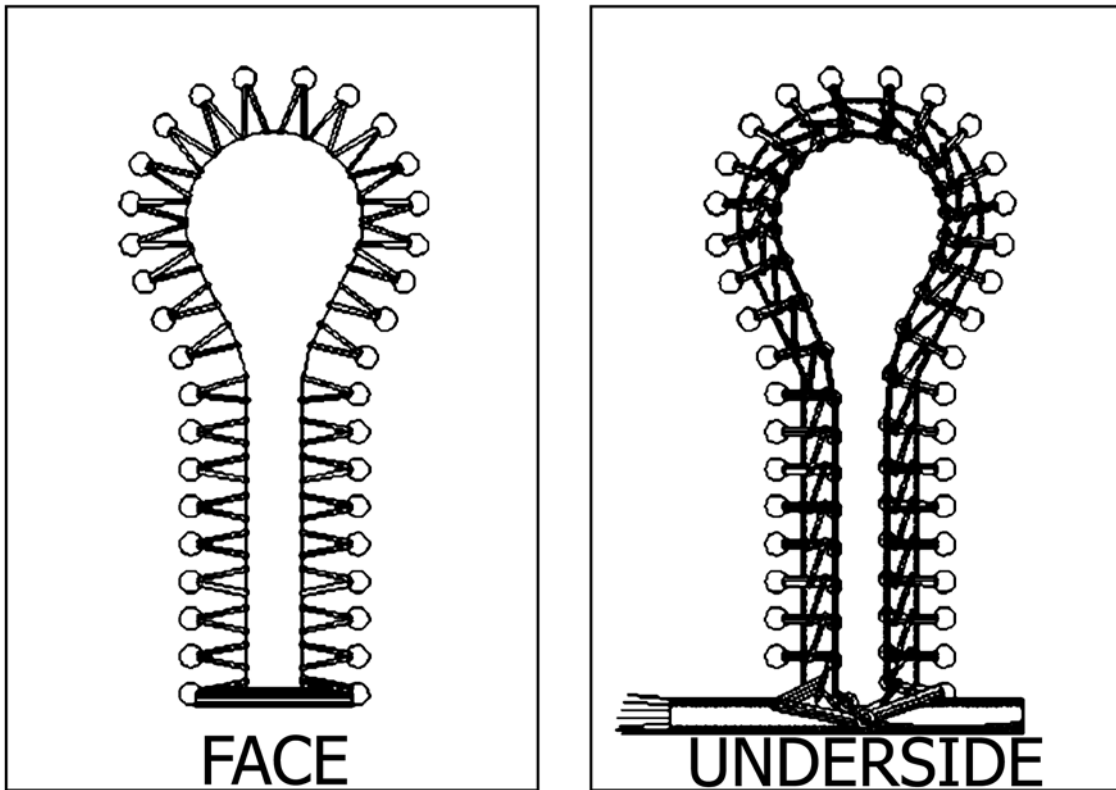

FIG. X1.10 Detailed Sketch of Eyelet-End Buttonhole

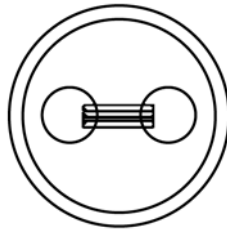

FIG. X1.11 Two Hole (Specify vertical/horizontal)



FIG. X1.12 Three Hole (Triangle)

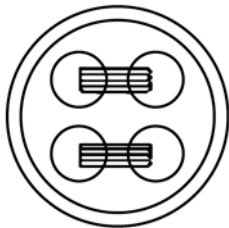

FIG. X1.13 Four Hole (Parallel)

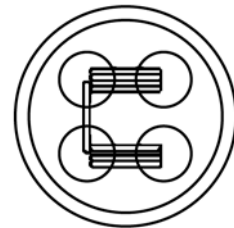

FIG. X1.16 Four Hole (1 Crossover, C Style)

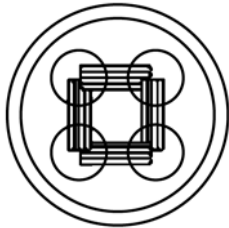

FIG. X1.14 Four Hole (Square)

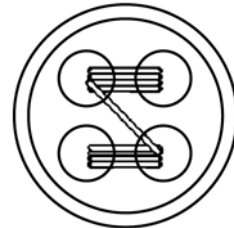

FIG. X1.17 Four Hole (1 Crossover, S Crossover St)



FIG. X1.15 Four Hole (Trident)



FIG. X1.18 Four Hole (1 Crossover, Z Crossover Style)



FIG. X1.19 Four Hole (X Pattern Syle)



FIG. X1.20 Four Hole (X Pattern/Crossover)

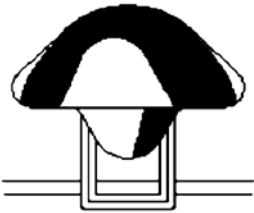

FIG. X1.21 Shank Button without Stay Button

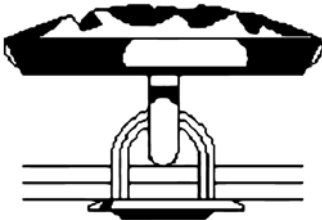

FIG. X1.22 Shank Button with Stay Button



FIG. X1.23 Neck Wrapped Around Button

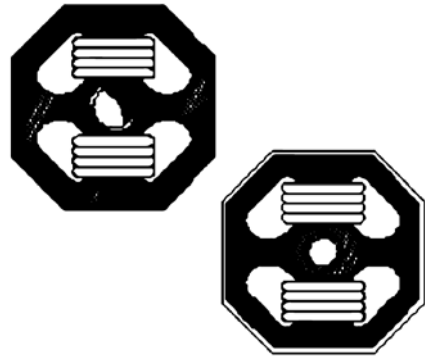

FIG. X1.24 Sewn Snap Fastener



FIG. X1.25 Sewn Hook and Eye

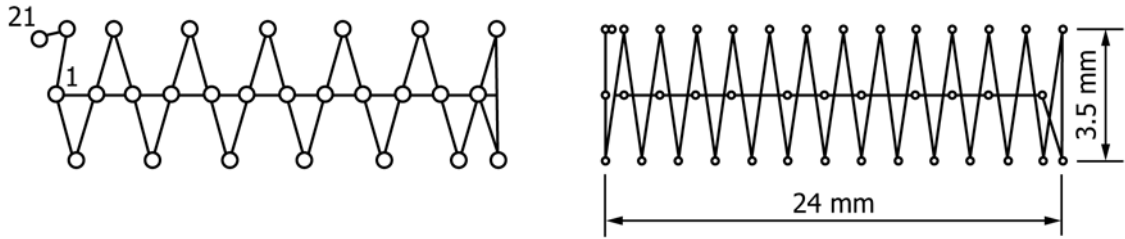

FIG. X1.26 Typical Small (left) and Typical Large (right)

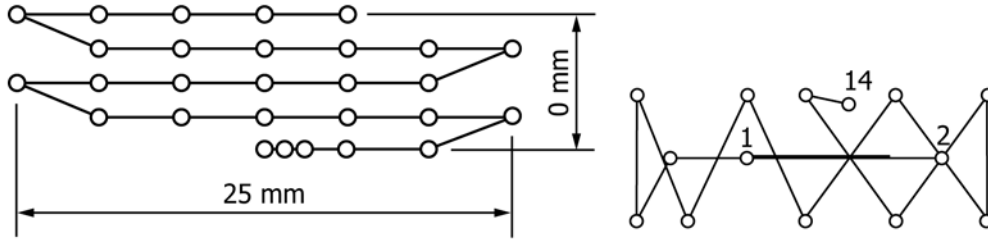

FIG. X1.27 Bartack – Typical Belt Loop (left) and Typical Knit (right)

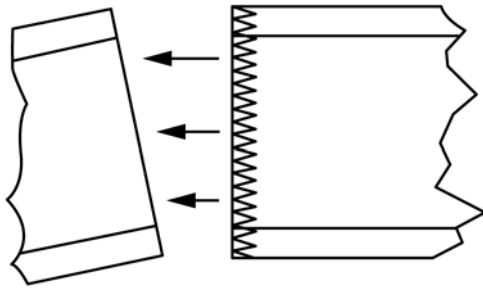

FIG. X1.28 Edge-Finish Tack

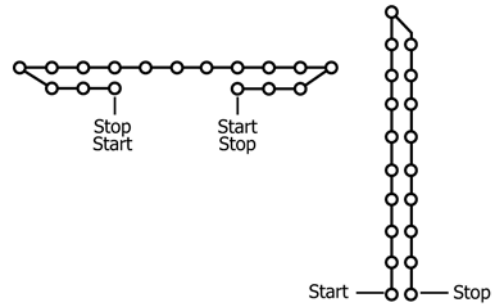

FIG. X1.31 Line/Straight Tack

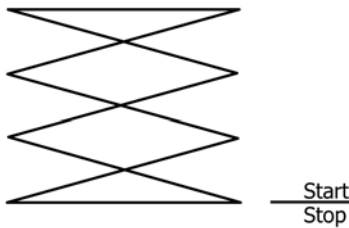

FIG. X1.29 Square Tack

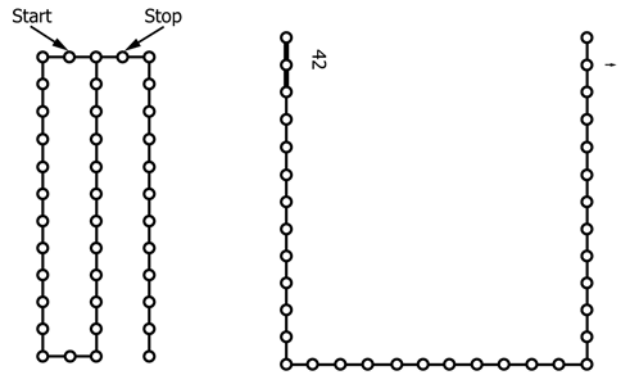

FIG. X1.32 U-Shaped

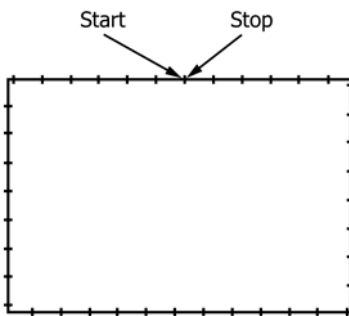

FIG. X1.30 Box/Rectangle Tack

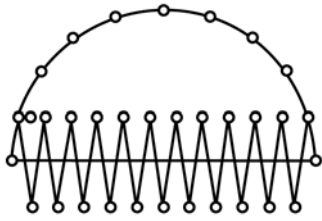
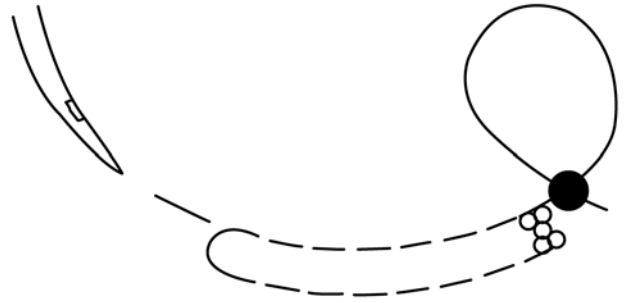

FIG. X1.33 Semicircular



NOTE 1—This type of stitch shall be formed with one needle thread that shall pass through the material and will be interlooped with itself on the underside of the material. The spot tack operation will generally be performed on a cycle type machine producing 6, 8 or 12 stitches per cycle.

FIG. X1.38 Spot Tack - 101 Stitch

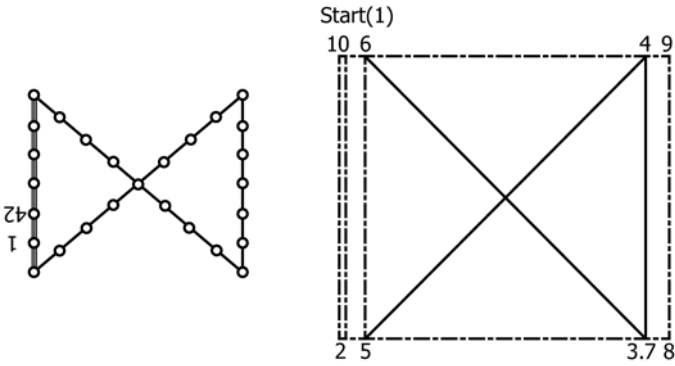

FIG. X1.34 X/Box-X

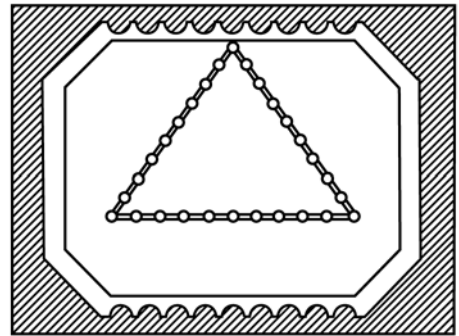

FIG. X1.39 Triangle Tack

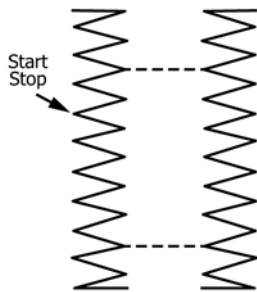

FIG. X1.35 Double Tack



FIG. X1.36 Ravel Tack

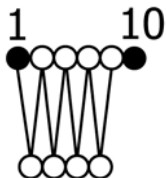

FIG. X1.37 Spot Tack

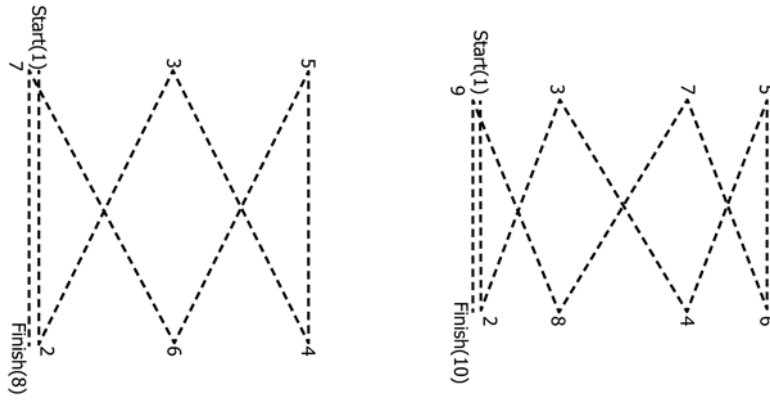

FIG. X1.40 W-Type (3 & 4 Pt.)

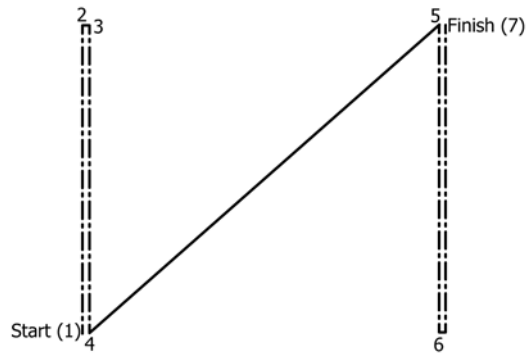

FIG. X1.41 Z-Type

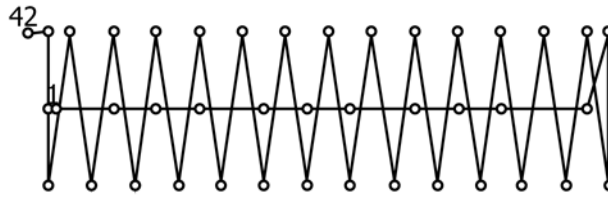

FIG. X1.42 Bartacks: 42 Total Stitches

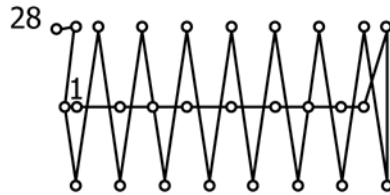

FIG. X1.43 Bartacks: 28 Total Stitches

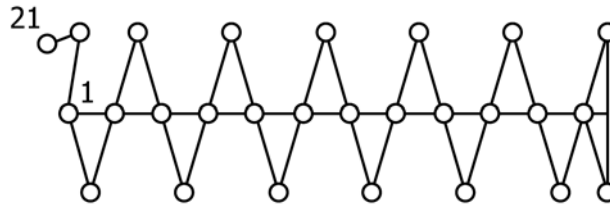

FIG. X1.44 Bartacks: 21 Total Stitches

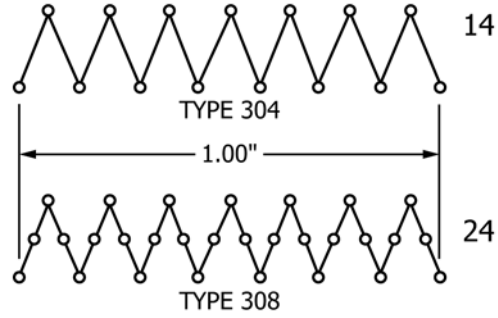
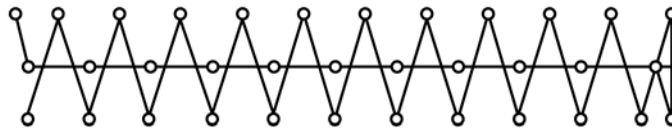

FIG. X1.45 Zig-Zag: Stitches per Inch



TYPICAL BARTACK
3/8" LONG, 36 STITCHES

FIG. X1.46 Zig-Zag: Total Stitches

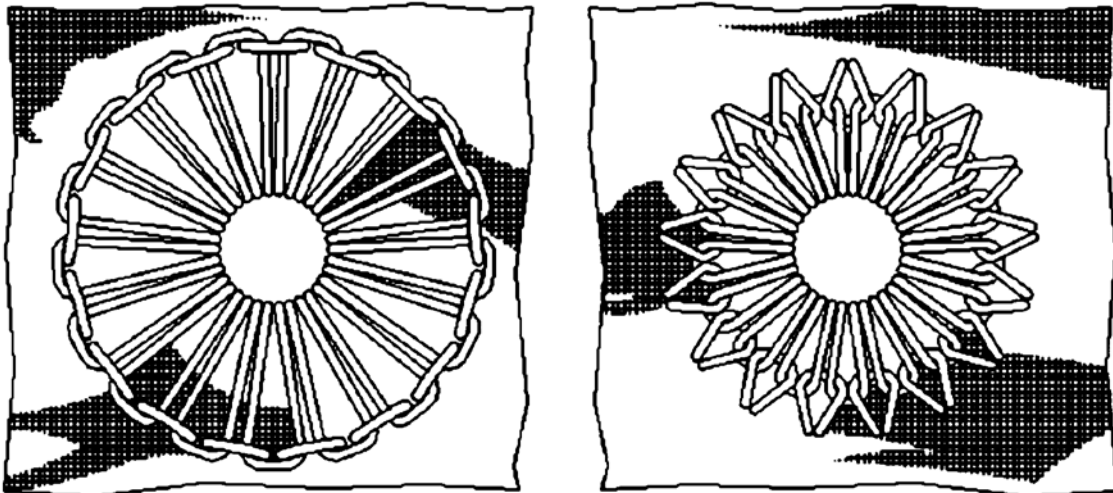

FIG. X1.47 Eyelet

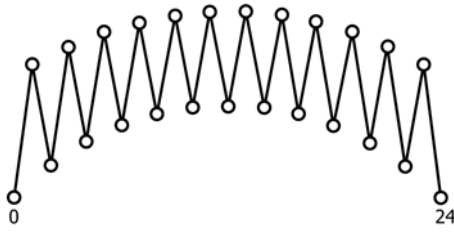

FIG. X1.48 Scallop

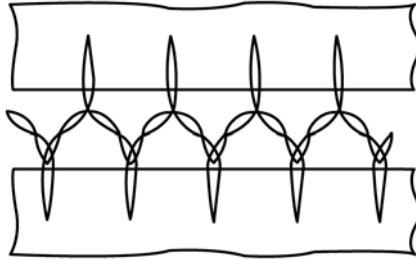

FIG. X1.49 Faggoting/Featherstitching

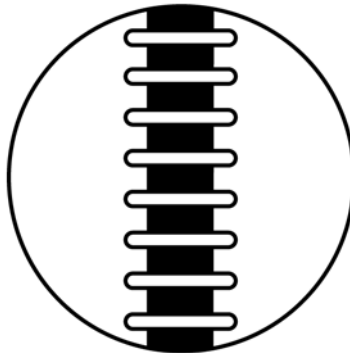

FIG. X1.50 Ladderstitch

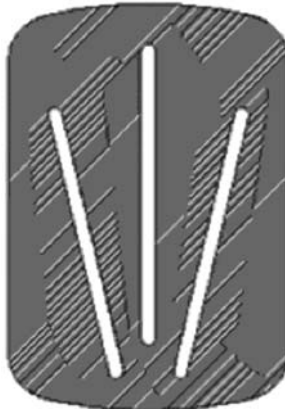

FIG. X1.51 Striping/Clocking



FIG. X1.52 Spiral Stitching

ASTM International takes no position respecting the validity of any patent rights asserted in connection with any item mentioned in this standard. Users of this standard are expressly advised that determination of the validity of any such patent rights, and the risk of infringement of such rights, are entirely their own responsibility.

This standard is subject to revision at any time by the responsible technical committee and must be reviewed every five years and if not revised, either reapproved or withdrawn. Your comments are invited either for revision of this standard or for additional standards and should be addressed to ASTM International Headquarters. Your comments will receive careful consideration at a meeting of the responsible technical committee, which you may attend. If you feel that your comments have not received a fair hearing you should make your views known to the ASTM Committee on Standards, at the address shown below.

This standard is copyrighted by ASTM International, 100 Barr Harbor Drive, PO Box C700, West Conshohocken, PA 19428-2959, United States. Individual reprints (single or multiple copies) of this standard may be obtained by contacting ASTM at the above address or at 610-832-9585 (phone), 610-832-9555 (fax), or service@astm.org (e-mail); or through the ASTM website (www.astm.org). Permission rights to photocopy the standard may also be secured from the Copyright Clearance Center, 222 Rosewood Drive, Danvers, MA 01923, Tel: (978) 646-2600; <http://www.copyright.com/>