



Designation: D613 – 17b



Designation: 41/2000

Standard Test Method for Cetane Number of Diesel Fuel Oil¹

This standard is issued under the fixed designation D613; the number immediately following the designation indicates the year of original adoption or, in the case of revision, the year of last revision. A number in parentheses indicates the year of last reapproval. A superscript epsilon (ϵ) indicates an editorial change since the last revision or reapproval.

This standard has been approved for use by agencies of the U.S. Department of Defense.

1. Scope*

1.1 This test method covers the determination of the rating of diesel fuel oil in terms of an arbitrary scale of cetane numbers using a standard single cylinder, four-stroke cycle, variable compression ratio, indirect injected diesel engine.

1.2 The cetane number scale covers the range from zero (0) to 100, but typical testing is in the range of 30 to 65 cetane number.

1.3 The values for operating conditions are stated in SI units and are to be regarded as the standard. The values given in parentheses are the historical inch-pound units for information only. In addition, the engine measurements continue to be in inch-pound units because of the extensive and expensive tooling that has been created for these units.

1.4 *This standard does not purport to address all of the safety concerns, if any, associated with its use. It is the responsibility of the user of this standard to establish appropriate safety and health practices and determine the applicability of regulatory limitations prior to use.* For more specific warning statements, see [Annex A1](#).

1.5 *This international standard was developed in accordance with internationally recognized principles on standardization established in the Decision on Principles for the Development of International Standards, Guides and Recommendations issued by the World Trade Organization Technical Barriers to Trade (TBT) Committee.*

¹ This test method is under the jurisdiction of ASTM Committee D02 on Petroleum Products, Liquid Fuels, and Lubricants and is the direct responsibility of Subcommittee D02.01 on Combustion Characteristics.

Current edition approved June 1, 2017. Published June 2017. Originally approved in 1941. Last previous edition approved in 2017 as D613 – 17a¹. DOI: 10.1520/D0613-17B.

2. Referenced Documents

2.1 ASTM Standards:²

- D975 Specification for Diesel Fuel Oils
- D1193 Specification for Reagent Water
- D2500 Test Method for Cloud Point of Petroleum Products and Liquid Fuels
- D3703 Test Method for Hydroperoxide Number of Aviation Turbine Fuels, Gasoline and Diesel Fuels
- D4057 Practice for Manual Sampling of Petroleum and Petroleum Products
- D4175 Terminology Relating to Petroleum Products, Liquid Fuels, and Lubricants
- D4177 Practice for Automatic Sampling of Petroleum and Petroleum Products
- D6299 Practice for Applying Statistical Quality Assurance and Control Charting Techniques to Evaluate Analytical Measurement System Performance
- E456 Terminology Relating to Quality and Statistics
- E542 Practice for Calibration of Laboratory Volumetric Apparatus
- E832 Specification for Laboratory Filter Papers

3. Terminology

3.1 Definitions:

3.1.1 *accepted reference value (ARV), n*—a value that serves as an agreed-upon reference for comparison, and which is derived as: (1) a theoretical or established value, based on scientific principles, or (2) an assigned or certified value, based on experimental work of some national or international organization, or (3) a consensus or certified value, based on collaborative experimental work under the auspices of a scientific or engineering group. **E456**

3.1.1.1 *Discussion*—In the context of this test method, accepted reference value is understood to apply to the cetane

² For referenced ASTM standards, visit the ASTM website, www.astm.org, or contact ASTM Customer Service at service@astm.org. For *Annual Book of ASTM Standards* volume information, refer to the standard's Document Summary page on the ASTM website.

*A Summary of Changes section appears at the end of this standard

number of specific reference materials determined empirically under reproducibility conditions by the National Exchange Group or another recognized exchange testing organization.

3.1.2 *cetane number (CN), n*—a measure of the ignition performance of a diesel fuel oil obtained by comparing it to reference fuels in a standardized engine test. **D4175**

3.1.2.1 *Discussion*—In the context of this test method, ignition performance is understood to mean the ignition delay of the fuel as determined in a standard test engine under controlled conditions of fuel flow rate, injection timing and compression ratio.

3.1.3 *compression ratio (CR), n*—the ratio of the volume of the combustion chamber including the precombustion chamber with the piston at bottom dead center to the comparable volume with the piston at top dead center.

3.1.4 *ignition delay, n*—that period of time, expressed in degrees of crank angle rotation, between the start of fuel injection and the start of combustion.

3.1.5 *injection timing (injection advance), n*—that time in the combustion cycle, measured in degrees of crank angle, at which fuel injection into the combustion chamber is initiated.

3.1.6 *quality control (QC) sample, n*—for use in quality assurance programs to determine and monitor the precision and stability of a measurement system, a stable and homogeneous material having physical or chemical properties, or both, similar to those of typical samples tested by the analytical measurement system. The material is properly stored to ensure sample integrity, and is available in sufficient quantity for repeated, long term testing. **D6299**

3.1.7 *repeatability conditions, n*—conditions where independent test results are obtained with the same method on identical test items in the same laboratory by the same operator using the same equipment within short intervals of time. **E456**

3.1.7.1 *Discussion*—In the context of this test method, a short time interval between two ratings on a sample fuel is understood to be not less than the time to obtain at least one rating on another sample fuel between them but not so long as to permit any significant change in the sample fuel, test equipment, or environment.

3.1.8 *reproducibility conditions, n*—conditions where test results are obtained with the same method on identical test items in different laboratories with different operators using different equipment. **E456**

3.2 *Definitions of Terms Specific to This Standard:*

3.2.1 *cetane meter, n*—the electronic apparatus which displays injection advance and ignition delay derived from input pulses of multiple transducers (pickups).

3.2.1.1 *Discussion*—In the context of this test method, three generations of apparatus have been approved for use as cetane meters. These are (year of introduction is parenthesis) the Mark II Ignition Delay Meter (1974), the Dual Digital Cetane Meter (1990), and the XCP Cetane Panel (2014).

3.2.2 *check fuels, n*—for quality control testing, a diesel fuel oil of selected characteristics having a cetane number accepted

reference value determined in accordance with Practice **D6299** requirements for check standards derived from interlaboratory exchange programs.

3.2.2.1 *Discussion*—When evaluating the interlaboratory data to establish the ARV, outlier identification and rejection criteria shall be applied at the 5 % significance level prior to computing the average result.

3.2.3 *combustion pickup, n*—pressure transducer exposed to cylinder pressure to indicate the start of combustion.

3.2.4 *handwheel reading, n*—an arbitrary numerical value, related to compression ratio, obtained from a micrometer scale that indicates the position of the variable compression plug in the precombustion chamber of the engine.

3.2.5 *injector opening pressure, n*—the fuel pressure that overcomes the resistance of the spring which normally holds the nozzle pintle closed, and thus forces the pintle to lift and release an injection spray from the nozzle.

3.2.6 *injector pickup, n*—transducer to detect motion of the injector pintle, thereby indicating the beginning of injection.

3.2.7 *primary reference fuels (PRF), n*—*n*-cetane, heptamethyl nonane (HMN) and volumetrically proportioned mixtures of these materials which now define the cetane number scale; the cetane number accepted reference value (CN_{ARV}) for any mixture of *n*-cetane and HMN is given by the relationship:

$$CN_{ARV} = \text{volume-} \% n\text{-cetane} + 0.15 (\text{volume-} \% \text{HMN}) \quad (1)$$

3.2.7.1 *Discussion*—In the context of this test method, the arbitrary cetane number scale was originally defined as the volume percent of *n*-cetane in a blend with alpha-methylnaphthalene (AMN) where *n*-cetane had an assigned value of 100 and AMN an assigned value of zero (0). A change from alpha-methylnaphthalene to heptamethylnonane as the low cetane ingredient was made in 1962 to utilize a material of better storage stability and availability. Heptamethylnonane was determined to have a cetane number accepted reference value (CN_{ARV}) of 15 based on engine testing by the ASTM Diesel National Exchange Group.³

3.2.7.2 *Discussion*—In the context of this test method, the Diesel National Exchange Group of Subcommittee D02.01⁴ is composed of petroleum industry, governmental, and independent laboratories. It conducts regular monthly exchange sample analyses to generate precision data for this engine test standard and determines the CN_{ARV} of reference materials used by all laboratories.

3.2.8 *reference pickups, n*—transducers or optical sensors mounted over the flywheel of the engine, triggered by a flywheel indicator, used to establish a top-dead-center (tdc) reference and a time base for calibration of the cetane meter.

3.2.9 *secondary reference fuels (SRF), n*—volumetrically proportioned blends of two selected, numbered, and paired

³ Supporting data have been filed at ASTM International Headquarters and may be obtained by requesting Research Report RR:D02-1092. Contact ASTM Customer Service at service@astm.org.

⁴ Bylaws governing ASTM Subcommittee D02.01 on Combustion Characteristics are available from the subcommittee or from ASTM International.

hydrocarbon mixtures designated *T Fuel* (high cetane) and *U Fuel* (low cetane) that have been rated by the ASTM Diesel National Exchange Group using primary reference fuels to determine a cetane number accepted reference value for each individually and for various combinations of the two.

3.3 Abbreviations:

- 3.3.1 *ABDC*—after bottom dead center
- 3.3.2 *AMN*—alpha-methylnaphthalene
- 3.3.3 *ARV*—accepted reference value
- 3.3.4 *ATDC*—after top dead center
- 3.3.5 *BBDC*—before bottom dead center
- 3.3.6 *BTDC*—before top dead center
- 3.3.7 *CN*—cetane number
- 3.3.8 *CR*—compression ratio
- 3.3.9 *HMN*—heptamethyl nonane
- 3.3.10 *HRF*—high reference fuel
- 3.3.11 *HW*—hand wheel
- 3.3.12 *IAT*—intake air temperature
- 3.3.13 *LRF*—low reference fuel
- 3.3.14 *NEG*—National Exchange Group
- 3.3.15 *PRF*—primary reference fuels
- 3.3.16 *SRF*—secondary reference fuels
- 3.3.17 *TDC*—top dead center
- 3.3.18 *UV*—ultraviolet

4. Summary of Test Method

4.1 The cetane number of a diesel fuel oil is determined by comparing its combustion characteristics in a test engine with those for blends of reference fuels of known cetane number under standard operating conditions. This is accomplished using the bracketing handwheel procedure which varies the compression ratio (handwheel reading) for the sample and each of two bracketing reference fuels to obtain a specific ignition delay permitting interpolation of cetane number in terms of handwheel reading.

5. Significance and Use

5.1 The cetane number provides a measure of the ignition characteristics of diesel fuel oil in compression ignition engines.

5.2 This test method is used by engine manufacturers, petroleum refiners and marketers, and in commerce as a primary specification measurement related to matching of fuels and engines.

5.3 Cetane number is determined at constant speed in a precombustion chamber type compression ignition test engine. The relationship of test engine performance to full scale, variable speed, variable load engines is not completely understood.

5.4 This test method may be used for unconventional fuels such as synthetics, vegetable oils, and the like. However, the relationship to the performance of such materials in full scale engines is not completely understood.

6. Interferences

6.1 (**Warning**—Avoid exposure of sample fuels and reference fuels to sunlight or fluorescent lamp UV emissions to minimize induced chemical reactions that can affect cetane number ratings.)⁵

6.1.1 Exposure of these fuels to UV wavelengths shorter than 550 nm for a short period of time may significantly affect cetane number ratings.

6.2 Certain gases and fumes present in the area where the cetane test engine is located may have a measurable effect on the cetane number test result.

6.3 This test method is not suitable for rating diesel fuel oils with fluid properties that interfere with unimpeded gravity flow of fuel to the fuel pump or delivery through the injector nozzle.

7. Apparatus

7.1 *Engine Equipment*^{6,7}—This test method uses a single cylinder engine which consists of a standard crankcase with fuel pump assembly, a cylinder with separate head assembly of the precombustion type, thermal syphon recirculating jacket coolant system, multiple fuel tank system with selector valving, injector assembly with specific injector nozzle, electrical controls, and a suitable exhaust pipe. The engine is belt connected to a special electric power-absorption motor which acts as a motor driver to start the engine and as a means to absorb power at constant speed when combustion is occurring (engine firing). See Fig. 1 and Table 1.

7.2 *Instrumentation*^{6,7}—This test method uses electronic apparatus to measure injection and ignition delay timing as well as conventional thermometry, gages and general purpose meters.

7.2.1 *Cetane Meter*—Use of an approved cetane meter is mandatory; only the XCP Cetane Panel or the Dual Digital Cetane Meter or the Mark II Ignition Delay Meter shall be used for this test method.

7.3 *Reference Fuel Dispensing Equipment*—This test method requires repeated blending of two secondary reference fuel materials in volumetric proportions on an as-needed basis. Measurement shall be performed accurately because rating error is proportional to blending error.

7.3.1 *Volumetric Blending of Reference Fuels*—Volumetric blending has historically been employed to prepare the required blends of reference fuels. For volumetric blending, a set of two burets or accurate volumetric ware shall be used and the desired batch quantity shall be collected in an appropriate container and thoroughly mixed before being introduced to the engine fuel system.

⁵ Supporting data have been filed at ASTM International Headquarters and may be obtained by requesting Research Report RR:D02-1502.

⁶ The sole source of supply of the engine equipment and instrumentation known to the committee at this time is Waukesha Engine, Dresser Inc., 1101 West St. Paul Avenue, Waukesha, WI 53188. Waukesha Engine also has CFR engine authorized sales and service organizations in selected geographical areas.

⁷ If you are aware of alternative suppliers, please provide this information to ASTM International Headquarters. Your comments will receive careful consideration at a meeting of the responsible technical committee,¹ which you may attend.

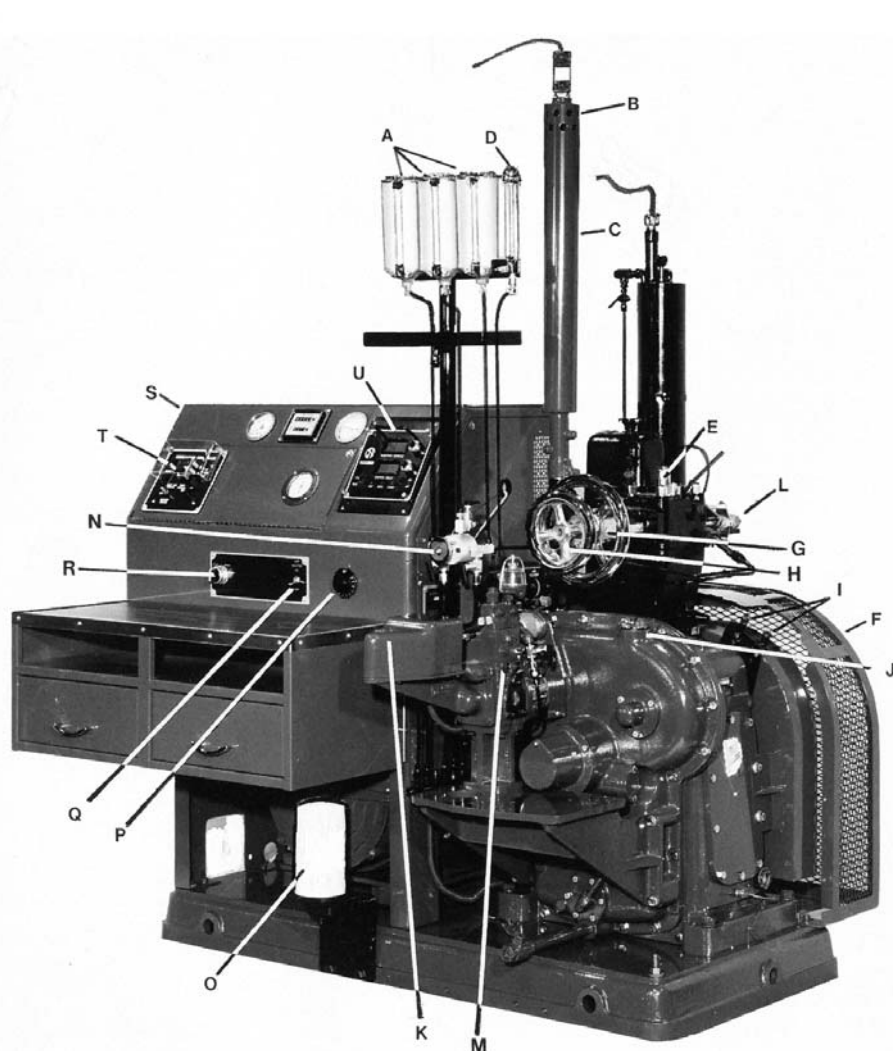

- A—Fuel Tanks
- B—Air Heater Housing
- C—Air Intake Silencer
- D—Fuel Flow Rate Buret
- E—Combustion Pickup
- F—Safety Guard
- G—Variable Compression Plug Handwheel
- H—V.C.P. Locking Handwheel
- I—Flywheel Pickups
- J—Oil Filler Cap
- K—Injection Pump Safety Shut-Off Solenoid
- L—Injector Assembly
- M—Fuel Injection Pump
- N—Fuel Selector-Valve
- O—Oil Filter
- P—Crankcase Oil Heater Control
- Q—Air Heater Switch
- R—Engine Start-Stop Switch
- S—Instrument Panel
- T—Intake Air Temperature Controller
- U—Dual Digital Cetane Meter

FIG. 1 Cetane Method Test Engine Assembly

7.3.1.1 Calibrated burets or volumetric ware having a capacity of 400 mL or 500 mL and a maximum volumetric tolerance of $\pm 0.2\%$ shall be used. Calibration shall be verified in accordance with Practice E542.

7.3.1.2 Calibrated burets shall be outfitted with a dispensing valve and delivery tip to accurately control dispensed volume. The delivery tip shall be of such size and design that shutoff tip discharge does not exceed 0.5 mL.

7.3.1.3 The rate of delivery from the dispensing system shall not exceed 500 mL per 60 s.

7.3.1.4 The set of burets for the reference and standardization fuels shall be installed in such a manner and be supplied with fluids such that all components of each batch or blend are dispensed at the same temperature.

7.3.1.5 See Appendix X1, Volumetric Reference Fuel Blending Apparatus and Procedures, for typical dispensing system information.

7.3.2 Gravimetric Blending of Reference Fuels—Use of blending systems that allow preparation of the volumetrically-

defined blends by gravimetric (mass) measurements based on the density of the individual components is also permitted, provided the system meets the requirement for maximum 0.2% blending tolerance limits.

7.3.2.1 Calculate the mass equivalents of the volumetrically-defined blend components from the densities of the individual components at 15.56 °C (60 °F).

7.4 Auxiliary Apparatus:

7.4.1 *Injector Nozzle Tester*—The injector nozzle assembly shall be checked whenever the injector nozzle is removed and reassembled to ensure the initial pressure at which fuel is discharged from the nozzle is properly set. It is also important to inspect the type of spray pattern. Commercial injector nozzle testers which include a lever-operated pressure cylinder, fuel reservoir and pressure gauge are available from several sources as common diesel engine maintenance equipment.

7.4.2 *Special Maintenance Tools*—A number of specialty tools and measuring instruments should be utilized for easy,

TABLE 1 General Engine Characteristics and Information

Item	Description
Crankcase	Model CFR-48 (Preferred), High or Low Speed Models (Optional)
Cylinder Type	Single bore cast iron with integral coolant jacket
Cylinder Head Type	Cast Iron with turbulence precombustion chamber, variable compression plug passage, integral coolant passages, and in-head valve assembly
Compression Ratio	Adjustable 8:1 to 36:1 by external handwheel assembly
Cylinder Bore (Diameter), in.	3.250 (Standard), Reboring to 0.010, 0.020, 0.030 over is acceptable
Stroke, in.	4.50
Displacement, cu in.	37.33
Valve Mechanism	In-head with enclosure
Intake and Exhaust Valves	Stellite faced, plain type without shroud
Piston	Cast iron, flat top
Piston Rings:	
Compression Type	4, Ferrous, straight sided (Top may be chrome plated—Optional)
Oil Control	1, Cast iron, one piece, slotted (Type 85)
Camshaft Over lap, degree	5
Fuel System	Injection pump with variable timing device and injector
Injector	Holder with bypass pressure release valve
Spray Nozzle	Closed, differential-needle, hydraulically-operated, pintle type
Weight of Engine	Approximately 400 kg (880 lb)
Weight of Complete Test Unit	Approximately 1250 kg (2750 lb)

convenient and effective maintenance of the engine and testing equipment. Lists and descriptions of these tools and instruments are available from the manufacturers of the engine equipment and those organizations offering engineering and service support for this test method.

8. Reagents and Reference Materials

8.1 *Cylinder Jacket Coolant*—Water shall be used in the cylinder jacket for laboratory locations where the resultant boiling temperature shall be 100 °C ± 2 °C (212 °F ± 3 °F). Water with commercial glycol-based antifreeze added in sufficient quantity to meet the boiling temperature requirement shall be used when laboratory altitude dictates. A commercial multifunctional water treatment material should be used in the coolant to minimize corrosion and mineral scale that can alter heat transfer and rating results.

8.1.1 Water shall be understood to mean reagent water conforming to Type IV of Specification **D1193**.

8.2 *Engine Crankcase Lubricating Oil*—An SAE 30 viscosity grade oil meeting current API service classification or compatible previous API service classifications shall be used. It shall contain a detergent additive and have a kinematic viscosity of 9.3 cSt to 12.5 cSt (mm² per s) at 100 °C (212 °F) and a viscosity index of not less than 85. Oils containing viscosity index improvers shall not be used. Multigraded oils shall not be used. (**Warning**—Lubricating oil is combustible, and its vapor is harmful. See **Annex A1**.)

8.3 *Primary Reference Fuels*—(**Warning**—Primary Reference Fuel—Combustible. Vapor harmful. See **Annex A1**.)

8.3.1 *n-Cetane (n-hexadecane)*—*n*-Cetane meeting the specifications in **Table 2** shall be used as the designated 100 cetane number component.

8.3.2 *Heptamethylnonane (2,2,4,4,6,8,8-heptamethylnonane)*—Heptamethylnonane meeting the specifications in **Table 2** shall be used as the designated 15 cetane number component.

8.3.3 Store and use primary reference fuels at temperatures of 20 °C or higher to avoid solidification of *n*-cetane, which has a melting point of 18 °C.

8.4 *Secondary Reference Fuels*—(**Warning**—Secondary reference fuel—combustible. Vapor harmful. See **Annex A1**.)

8.4.1 *T Fuel*—Diesel fuel meeting the specifications in **Table 3**.

8.4.2 *U Fuel*—Diesel fuel meeting the specifications in **Table 3**.

8.4.3 Storage and use of *T Fuel* and *U Fuel* should be at temperatures above 0 °C (32 °F) to avoid potential solidification, particularly of *T Fuel*. Before a container that has been stored at low temperature is placed in service, it should be warmed to a temperature of at least 14 °C (26 °F) above its Cloud Point. (See Test Method **D2500**.) It should be held at this temperature for a period of at least 30 min and then the container should be thoroughly remixed.

8.4.4 As secondary reference fuel blends are rated in numbered pairs, they are not interchangeable with reference fuels from other numbered pairs and shall not be mixed.

8.5 *Check Fuels*⁸—Diesel fuel oils having properties other than CN that are typical of Specification **D975** grade No. 2-D S15. (**Warning**—Check Fuel—Combustible. Vapor harmful. See **Annex A1**.)

8.5.1 *Low Cetane Check Fuel*, meeting the specifications in **Table 3**.

8.5.2 *High Cetane Check Fuel*, meeting the specifications in **Table 3**.

9. Sampling

9.1 Collect samples in accordance with Practice **D4057** or **D4177**.

9.1.1 *Protection from Light*—Collect and store sample fuels in an opaque container such as a dark brown glass bottle, metal can, or a minimally reactive plastic container to minimize exposure to UV emissions from sources such as sunlight or fluorescent lamps.

9.2 *Fuel Temperature*—Samples shall be brought to room temperature typically 18 °C to 32 °C (65 °F to 90 °F) before engine testing.

9.2.1 The fuel temperature should be raised at least 14 °C (26 °F) above the fuel's cloud point. The fuel sample should be homogeneous before engine testing or filtration (**9.3**).

NOTE 1—Give consideration to the fuel's composition related to sample temperature to avoid the loss of any lower boiling components that may affect the cetane rating.

9.3 *Filtration*—Samples may be filtered through a Type I, Class A filter paper at room temperature and pressure before engine testing. See Specification **E832**.

⁸ Blend Tables for batches of *T Fuel* and *U Fuel* can be obtained from the fuel supplier.

TABLE 2 Specifications for Primary Reference Fuels

Property	<i>n</i> -Cetane	Heptamethylnonane	Test Method
Purity, mass %, minimum	99.0	98.0	Gas chromatography
Hydroperoxide number, mg/kg as O, maximum	5.0	5.0	ASTM D3703

TABLE 3 Specifications for Secondary Reference Fuels and Check Fuels

Property	Secondary Reference Fuels		Check Fuels		Test Method
	T-Fuel	U-Fuel	Low	High	
Cetane number ARV, minimum	73	19	38.	50.	ASTM D613
Cetane number ARV, maximum	76	22	42.	55.	ASTM D613
Hydroperoxide number, mg/kg as O, maximum	5.0	5.0	5.0	5.0	ASTM D3703

10. Basic Engine and Instrument Settings and Standard Operating Conditions

10.1 *Installation of Engine Equipment and Instrumentation*—Installation of the engine and instrumentation requires placement of the engine on a suitable foundation and hookup of all utilities. Engineering and technical support for this function is required, and the user shall be responsible to comply with all local and national codes and installation requirements.

10.1.1 Proper operation of the test engine requires assembly of a number of engine components and adjustment of a series of engine variables to prescribed specifications. Some of these settings are established by component specifications, others are established at the time of engine assembly or after overhaul and still others are engine running conditions that must be observed or determined by operator adjustment, or both, during the testing process.

10.2 Conditions Based on Component Specifications:

10.2.1 *Engine Speed*—900 r/min \pm 9 r/min, when the engine is operating with combustion with a maximum variation of 9 r/min occurring during a rating. Engine speed when combustion is occurring shall not be more than 3 r/min greater than that for motoring without combustion.

10.2.2 *Valve Timing*—The engine uses a four-stroke cycle with two crankshaft revolutions for each complete combustion cycle. The two critical valve events are those that occur near TDC; intake valve opening and exhaust valve closing.

10.2.2.1 Intake valve opening shall occur 10.0° \pm 2.5° ATDC with closing at 34° ABDC on one revolution of the crankshaft and flywheel.

10.2.2.2 Exhaust valve opening shall occur 40° BBDC on the second revolution of the crankshaft or flywheel with closing at 15.0° \pm 2.5° ATDC on the next revolution of the crankshaft or flywheel.

10.2.3 *Valve Lift*—Intake and exhaust cam lobe contours, while different in shape, shall have a contour rise of 6.223 mm to 6.350 mm (0.245 in. to 0.250 in.) from the base circle to the top of the lobe so that the resulting valve lift shall be 6.045 mm \pm 0.05 mm (0.238 in. \pm 0.002 in.).

10.2.4 *Fuel Pump Timing*—Closure of the pump plunger inlet port shall occur at a flywheel crank angle between 300° and 306° on the engine compression stroke when the fuel flow-rate-micrometer is set to a typical operating position and the variable timing device lever is at full advance (nearest to operator).

10.2.5 *Fuel Pump Inlet Pressure*—A minimum fuel head established by assembly of the fuel tanks (storage reservoirs) and flow rate measuring buret so that the discharge from them is 635 mm \pm 25 mm (25 in. \pm 1 in.) above the centerline of the fuel injection pump inlet.

10.3 Assembly Settings and Operating Conditions:

10.3.1 *Direction of Engine Rotation*—Clockwise rotation of the crankshaft when observed from the front of the engine.

10.3.2 *Injection Timing*—13.0° BTDC, for the sample and reference fuels.

10.3.3 *Injector Nozzle Opening Pressure*—10.3 MPa \pm 0.34 MPa (1500 psi \pm 50 psi).

10.3.4 *Injection Flow Rate*—13.0 mL/min \pm 0.2 mL/min (60 s \pm 1 s per 13.0 mL).

10.3.5 *Injector Coolant Passage Temperature*—38 °C \pm 3 °C (100 °F \pm 5 °F).

10.3.6 Valve Clearances:

10.3.6.1 *Engine Running and Hot*—The clearance for both intake and exhaust valves shall be set to 0.20 mm \pm 0.025 mm (0.008 in. \pm 0.001 in.), measured under standard operating conditions with the engine running at equilibrium conditions on a typical diesel fuel oil.

10.3.7 *Oil Pressure*—172 kPa to 207 kPa (25 psi to 30 psi).

10.3.8 *Oil Temperature*—57 °C \pm 8 °C (135 °F \pm 15 °F).

10.3.9 *Cylinder Jacket Coolant Temperature*—100 °C \pm 2 °C (212 °F \pm 3 °F).

10.3.10 *Intake Air Temperature*—66 °C \pm 0.5 °C (150 °F \pm 1 °F).

10.3.11 *Basic Ignition Delay*—13.0° for the sample and reference fuels.

10.3.12 Cylinder Jacket Coolant Level:

10.3.12.1 *Engine Stopped and Cold*—Treated water/coolant added to the cooling condenser—cylinder jacket to a level just observable in the bottom of the condenser sight glass will typically provide the controlling engine running and hot operating level.

10.3.12.2 *Engine Running and Hot*—Coolant level in the condenser sight glass shall be within \pm 1 cm (0.4 in.) of the LEVEL HOT mark on the coolant condenser.

10.3.13 Engine Crankcase Lubricating Oil Level:

10.3.13.1 *Engine Stopped and Cold*—Oil added to the crankcase so that the level is near the top of the sight glass will typically provide the controlling engine running and hot operating level.

10.3.13.2 *Engine Running and Hot*—Oil level shall be approximately mid-position in the crankcase oil sight glass.

10.3.14 *Crankcase Internal Pressure*—As mentioned by a gauge or manometer connected to an opening to the inside of the crankcase through a snubber orifice to minimize pulsations, the pressure shall be less than zero (a vacuum) and typically from 25 mm to 150 mm (1 in. to 6 in.) of water less than atmospheric pressure. Vacuum shall not exceed 255 mm (10 in.) of water.

10.3.15 *Exhaust Back Pressure*—As measured by a gauge or manometer connected to an opening in the exhaust surge tank or main exhaust stack through a snubber orifice to minimize pulsations, the static pressure should be as low as possible, but shall not create a vacuum nor exceed 254 mm (10 in.) of water differential in excess of atmospheric pressure.

10.3.16 *Exhaust and Crankcase Breather System Resonance*—The exhaust and crankcase breather piping systems shall have internal volumes and be of such length that gas resonance does not result.

10.3.17 *Piston Over-Travel*—Assembly of the cylinder to the crankcase shall result in the piston protruding above the top of the cylinder surface $0.381\text{ mm} \pm 0.025\text{ mm}$ ($0.015\text{ in.} \pm 0.001\text{ in.}$) when the piston is at top-dead-center. Proper positioning is accomplished through the use of plastic or paper gaskets, available in several thicknesses and selected by trial and error for assembly between the cylinder and crankcase deck.

10.3.18 *Belt Tension*—The belts connecting the flywheel to the absorption motor shall be tightened, after an initial break-in, so that with the engine stopped, a 2.25 kg (5 lb) weight suspended from one belt half way between the flywheel and motor pulley shall depress the belt approximately 12.5 mm (0.5 in.).

10.3.19 *Setting Injector Nozzle Assembly Pressure and Spray Pattern Check*—(Warning—Personnel shall avoid contact with the spray pattern from injector nozzles because of the high pressure which can penetrate the skin. Spray pattern performance checks shall be made in a hood or where adequate ventilation insures that inhalation of the vapors is avoided.)

10.3.19.1 *Injector Opening or Release Pressure*—The pressure adjusting screw is adjustable and shall be set to release fuel at a pressure of $10.3\text{ MPa} \pm 0.34\text{ MPa}$ ($1500\text{ psi} \pm 50\text{ psi}$). Check this setting using an injector nozzle bench tester, each time the nozzle is reassembled and after cleaning. Use of a commercial injector nozzle bench tester is recommended. See Annex A2 for procedural detail.

10.3.19.2 *Injector Spray Pattern*—Check the spray pattern for symmetry and characteristic by inspection of the impression of a single injection made on a piece of filter paper or other slightly absorbent material placed at a distance of approximately 7.6 cm (3 in.) from the nozzle. A typical spray pattern is illustrated in Fig. 2.

10.3.20 *Indexing Handwheel Reading*—Handwheel readings are a simple and convenient indication of engine compression ratio which is a critical variable in the cetane method of test. The actual compression ratio is not important but an indication of compression ratio which relates to cetane number is a useful guide for selecting reference fuels to bracket the



FIG. 2 Typical Injector Spray Pattern

sample of diesel fuel oil. The following procedure shall be used to index the handwheel reading when the engine is new or anytime the matched handwheel assembly/cylinder head combination is interchanged or mechanically reassembled.

10.3.20.1 *Handwheel Micrometer Drum and Scale Setting*—Refer to Table 4 to select the appropriate handwheel reading to be used in aligning the drum and scale.

10.3.20.2 *Basic Setting of Variable Compression Plug*—Position the variable compression plug so that the flat surface is just visible and exactly in line with the edge of the threads of the combustion pickup hole, as verified with a straightedge.

10.3.20.3 *Setting Handwheel Reading*—Tighten the small locking handwheel snugly by hand to ensure that the variable compression plug is held in place in the bore. Loosen the lock nut of the large handwheel and remove the locking L-shaped key. Turn the large handwheel so that the edge of the drum is in alignment with the 1.000 graduation on the horizontal scale. Reinstall the L-shaped key in the nearest keyway slot of the large handwheel with the shorter leg in the handwheel. A slight shifting of the handwheel to achieve slot lineup will not affect the indexing. Tighten the lock nut hand-tight to hold the key in place. Remove the locating screw from the drum and rotate the drum so that the zero graduation mark is in line with the selected reading from Table 4. Locate the screw hole in the drum which lines up with the handwheel hub hole and reinstall the locating screw. Wrench tighten the large handwheel lock nut and recheck that the variable compression plug is properly positioned and the handwheel reading is in accordance with the value in Table 4.

10.3.21 *Basic Compression Pressure*—At a handwheel reading of 1.000, the compression pressure for an engine operated at standard barometric pressure of 760 mm Hg. (29.92 in. Hg) shall be $3275\text{ kPa} \pm 138\text{ kPa}$ ($475\text{ psi} \pm 20\text{ psi}$) when read as quickly as possible after shutdown of the engine which had been at standard operating conditions. If the condition is not within limits, recheck the basic handwheel setting and, if necessary, perform mechanical maintenance. See Annex A2 for the Checking Compression Pressure procedure.

10.3.21.1 For engines operated at other than standard barometric pressure, the compression pressure will typically be in proportion to the ratio of the local barometric pressure divided by standard barometric pressure. As an example, an engine located where the barometric pressure is 710 mm Hg would be expected to have a compression pressure of approximately $3060\text{ kPa} \pm 138\text{ kPa}$ ($444\text{ psi} \pm 20\text{ psi}$). (Warning—In addition to other precautions, compression pressure testing using a compression pressure gauge should be completed in as short a

TABLE 4 Handwheel Setting for Various Cylinder Bore Diameters

Cylinder Diameter, in.		Handwheel Reading
3.250	(Standard Bore)	1.000
3.260	(Rebored 0.010 in. Oversize)	0.993
3.270	(Rebored 0.020 in. Oversize)	0.986
3.280	(Rebored 0.030 in. Oversize)	0.978

period of time as possible to avoid the possibility of combustion occurrence due to the presence of any small amount of oil in the gauge or combustion chamber.)

$$\text{Compression Pressure}_{(\text{LocalBaro.}, \text{mmHg})} \quad (2)$$

$$= 3275 \text{ kPa} \times \text{Local Baro./Standard Baro.}$$

$$\text{Example: Compression Pressure}_{710\text{mmHg}}$$

$$= 3275 \times 710/760 = 3060 \text{ kPa}$$

10.3.22 Fuel Pump Lubricating Oil Level—With the engine stopped, sufficient engine crankcase lubricating oil shall be added to the pump sump so that the level is at the mark on the dip stick. (**Warning**—As a result of engine operation, especially when the pump barrel/plunger assembly begins to wear, the level in the sump will increase due to fuel dilution as observed through a clear plastic side plate on the pump housing. When the level rises appreciably, the sump should be drained and a fresh charge of oil added.)

10.3.23 Fuel Pump Timing Gear Box Oil Level—With the engine stopped, unplug the openings on the top and at the mid-height of either side of the gear box. Add sufficient engine crankcase lubricating oil through the top hole to cause the level to rise to the height of the side opening. Replug both openings. (**Warning**—The pump and timing gear box oil sumps are not connected to each other and the lubrication for the two is independent.)

10.3.24 Instrumentation—Positioning of the reference pickups and injector pickup is important to ensure that timing of the injection and ignition delay functions is uniform and correct.

10.3.24.1 Setting Reference Pickups—These two pickups are identical and interchangeable. They are installed in a bracket positioned over the flywheel so that they clear the flywheel indicator which triggers them.

10.3.24.2 Position each pickup in the bracket so that it is properly referenced to the flywheel indicator in accordance with the instructions supplied with the specific pickup.

10.3.24.3 Measurement of pickup to flywheel indicator clearance, if required, shall be made using a nonmagnetic feeler gauge.

10.3.25 Setting Injector Pickup Gap—Set the air gap to typically 1 mm (0.040 in.) with the engine stopped.

10.3.25.1 Individual pickups may require more or less air gap to obtain steady meter operation when the engine is ultimately running but too little gap can cause the ignition delay angle display to drive off scale. Follow instructions supplied with the specific pickup to optimize the gap setting.

11. Calibration and Engine Qualification

11.1 Engine Compliance—It is assumed that the engine has been commissioned and that all settings and operating vari-

ables are at equilibrium and in compliance with basic engine and instrument settings and standard operating conditions.

11.1.1 Engine warm-up requires typically 1 h to ensure that all critical variables are stable.

11.2 Checking Performance on Check Fuels—This engine test does not have any satisfactory standardization fuel blend or blends to qualify the engine. The Check Fuels are the most helpful means available to permit judgement of good performance.

11.2.1 Test one or more of the Check Fuels.

11.2.2 Engine performance is judged satisfactory if the cetane rating obtained on a Check Fuel is within the Check Fuel tolerance limits calculated as follows:

$$\text{Tolerance Limits} = CN_{ARV} \pm 1.5 \times S_{ARV} \quad (3)$$

where:

CN_{ARV} = the cetane number accepted reference value of the Check Fuel,

1.5 = a selected tolerance limit factor (K) for normal distributions,

S_{ARV} = the standard deviation of the Check Fuel data used to determine CN_{ARV} .

11.2.2.1 In the context of this test method, the statistical tolerance limit factor (K), based on a sample size (n), permits an estimation of the percentage of engines that would be able to rate the Check Fuel within the calculated tolerance limits. Based on a data set of 17 to 20 ratings used to determine the Check Fuel CN_{ARV} , and a value of $K = 1.5$, it is estimated that in the long run, in 19 cases out of 20, at least 70 % of the engines would rate the Check Fuel within the calculated tolerance limits.

11.2.3 If the results are outside this tolerance range, the engine is not acceptable for rating samples and a check of all operating conditions is warranted followed by mechanical maintenance which may require critical parts replacement. The injector nozzle can be a very critical factor and this should be the first item checked or replaced to achieve rating compliance.

11.3 Quality Control (QC Testing)—Users should conduct a regular statistical quality control program to monitor the engine is in statistical control over time.

11.3.1 This test method suggests validating the engine system by the rating of a QC sample.

11.3.2 The QC sample is a diesel fuel oil having a cetane number within the normal operating range of the engine.

11.3.2.1 Users are encouraged to assess the normal operating range and determine if multiple QC samples are required based upon the cetane number range of the samples typically rated.

11.3.3 Use appropriate control charts or other statistically equivalent techniques to assess the cetane number value. Control charts often used for this application are Individuals and Moving Range (I/MR).

11.3.4 Specifics for control chart set up and interpretation can be found in Practice [D6299](#).

11.3.5 If an out-of-statistical control situation is detected, examine the engine system operation for assignable cause(s).

12. Procedure

12.1 *Bracketing by Handwheel Procedure*—See [Appendix X2](#) for the details of engine operation and the adjustment of each of the individual operating variables.

12.1.1 Check that all engine operating conditions are in compliance and equilibrated with the engine running on a typical diesel fuel oil. (**Warning**—In addition to other precautions, always position the Mark II Ignition Delay Meter to CALIBRATE before proceeding with fuel switching so that violent meter needle full-scale pegging does not occur. Calibration adjustment should be checked before each rating but never changed during a rating.)

12.1.2 Introduce the sample to an empty fuel tank, rinse the fuel buret, purge any air from the fuel line to the pump and position the fuel-selector valve to operate the engine on this fuel. (**Warning**—Sample and Fuel—Combustible. Vapor harmful. See [Annex A1](#).)

12.1.3 *Fuel Flow Rate*—Check the fuel flow rate and adjust the flow-rate-micrometer of the fuel pump to obtain 13 mL per min consumption. The final flow rate measurement shall be made over a full $60\text{ s} \pm 1\text{ s}$ period. Note the flow-rate-micrometer reading for reference.

12.1.4 *Fuel Injection Timing*—After establishing the fuel flow rate, adjust the injection-timing-micrometer of the fuel pump assembly to obtain a $13.0^\circ \pm 0.2^\circ$ injection advance reading. Note the injection-timing-micrometer reading for reference.

12.1.5 *Ignition Delay*—Adjust the handwheel to change the compression ratio and obtain a $13.0^\circ \pm 0.2^\circ$ ignition delay reading. Make the final handwheel adjustment in the clockwise direction (viewed from front of engine) to eliminate backlash in the handwheel mechanism and a potential error.

12.1.6 *Equilibration*—It is important to achieve stable injection advance and ignition delay readings.

12.1.6.1 Stable readings should typically occur within 5 min to 10 min.

12.1.6.2 The time used for the sample and each of the reference fuels should be consistent and shall not be less than 3 min.

12.1.7 *Handwheel Reading*—Observe and record the handwheel reading as the representative indication of the combustion characteristic for this fuel sample.

NOTE 2—Experience has shown that if handwheel readings are taken when the fuel tank levels of samples and reference fuels are similar, more consistent results are obtained.

12.1.8 *Reference Fuel No. 1*—Select a reference fuel blend close to the estimated cetane number of the sample.

NOTE 3—The handwheel reading versus cetane number relationship based on this procedure is engine and overhaul dependent but it can be established for each engine as testing experience is gained after each overhaul. A plot or table of handwheel readings provides a simple guide to selection of the reference fuel.

12.1.8.1 If primary reference fuels are being used for the rating, select a blend of *n*-cetane and HMN having a cetane number close to the estimated cetane number of the sample.

12.1.8.2 If secondary reference fuels are being used for the rating and the cetane number of the sample is expected to be less than the ARV of *T Fuel*, select a blend of *T Fuel* and *U*

TABLE 5 Reference Fuel Blends for Samples with Cetane Number > *T Fuel*

Blend	<i>T Fuel</i> , vol- %	<i>n</i> -Cetane, vol- %
1	100	0
2	75	25
3	50	50
4	25	75
5	0	100

Fuel having a cetane number close to the estimated cetane number of the sample.

12.1.8.3 If secondary reference fuels are being used for the rating and the cetane number of the sample is expected to be greater than the ARV of *T Fuel*, select a blend of *T Fuel* and *n*-cetane from [Table 5](#).

12.1.8.4 Prepare a fresh 400 mL or 500 mL batch of the selected reference blend.

12.1.8.5 Introduce Reference Fuel No. 1 to one of the unused fuel tanks taking care to flush the fuel lines in the same manner as noted for the sample.

12.1.8.6 Perform the same adjustment and measurement steps used for the sample and record the resulting handwheel reading.

12.1.9 *Reference Fuel No. 2*—Select another reference fuel blend which can be expected to result in a handwheel reading that causes the two reference fuel handwheel readings to bracket that for the sample.

12.1.9.1 If primary reference fuels are being used for the rating, select another blend of *n*-cetane and HMN. The difference in *n*-cetane content of the two primary reference fuel blends shall not exceed 7 volume percent. (PRF blends differing by 7 volume percent *n*-cetane have defined cetane numbers that differ by 5.95.)

12.1.9.2 If secondary reference fuels are being used for the rating and the cetane number of the sample is less than the ARV of *T Fuel*, select another blend of *T Fuel* and *U Fuel*. The difference between these two secondary reference fuel blends shall not exceed 5.6 cetane numbers. Typically, blends differing by 5 volume percent *T Fuel* will span about 2.7 cetane numbers and those differing by 10 volume percent *T Fuel* will span about 5.3 cetane numbers.

12.1.9.3 If secondary reference fuels are being used for the rating and the cetane number of the sample is greater than the ARV of *T Fuel*, select a blend of *T Fuel* and *n*-cetane from [Table 5](#) that is adjacent to the *T-Fuel/n*-cetane blend tested above.

12.1.9.4 Prepare a fresh 400 mL or 500 mL batch of the selected reference fuel blend.

12.1.9.5 Introduce Reference Fuel No. 2 to the third fuel tank taking care to flush the fuel lines in the same manner as noted for the sample.

12.1.9.6 Perform the same adjustment and measurement steps used for the sample and first reference fuel and record the resulting handwheel reading.

NOTE 4—Typically, the fuel-flow-rate should be the same for both reference fuels because they are sufficiently similar in composition.

12.1.9.7 If the handwheel reading for the sample is bracketed by those of the reference fuel blends calculate the cetane

SAMPLE AND REFERENCE FUEL READING SEQUENCE A

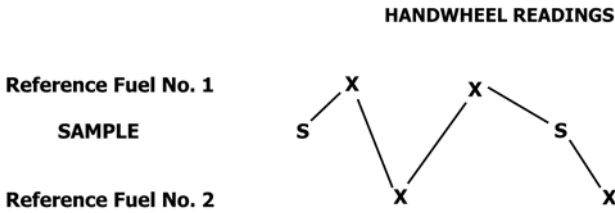

SAMPLE AND REFERENCE FUEL READING SEQUENCE B

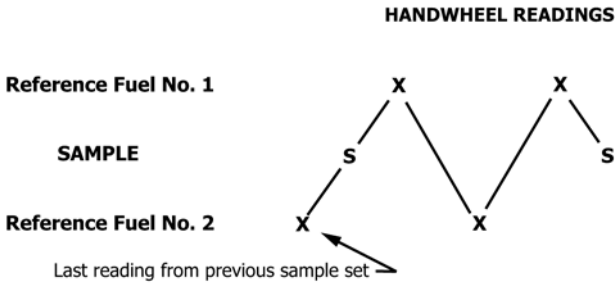
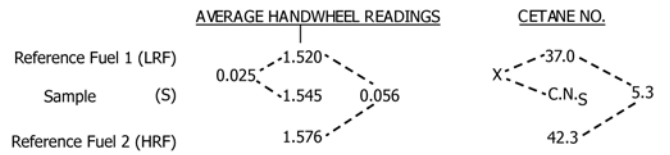

FIG. 3 Sample and Reference Fuel Reading Sequence

HANDWHEEL BRACKETING PROCEDURE



$$\begin{aligned}
 CN_S &= CN_{LRF} + \left(\frac{HW_S - HW_{LRF}}{HW_{HRF} - HW_{LRF}} \right) (CN_{HRF} - CN_{LRF}) \\
 &= 37.0 + \left(\frac{1.545 - 1.520}{1.576 - 1.520} \right) (42.3 - 37.0) \\
 &= 37.0 + (0.446) (5.3) = 39.4
 \end{aligned}$$

FIG. 4 Example of Cetane Number Calculations

number, in accordance with Eq 4, from the handwheel readings of the sample and each of the bracketing reference fuels and continue the test; otherwise try an additional reference fuel blend(s) until this requirement is satisfied.

12.1.10 Repeat Readings—After operation on a satisfactory second reference fuel blend, perform the necessary steps to rerun Reference Fuel No. 1, then the sample and finally Reference Fuel No. 2. For each fuel, be certain to check all parameters carefully and allow operation to reach equilibrium before recording the handwheel readings. The fuel switching shall be as illustrated in Fig. 3 Sample and Reference Fuel Reading Sequence A.

12.1.10.1 Calculate the cetane number, in accordance with Eq 4, from the second set of handwheel readings from the sample and each of the bracketing reference fuels.

12.1.10.2 The cetane number calculated from the average of the two handwheel readings for the sample fuel and the average of the two handwheel readings for each of the reference fuels constitute a rating providing the difference between the cetane numbers calculated in the first and second series of readings is no greater than 1.4 CN.

NOTE 5—Determinability limits of 1.4 CN are in place to limit the instability of the engine and the effect this can have on the ratings.

12.1.10.3 If the cetane numbers calculated in the first and second series of readings do not meet this criterion a third set of readings may be obtained using the same sequence of Sample, Reference Fuel 1, Reference Fuel 2 that was employed for the initial sequence.

12.1.10.4 Calculate the cetane number, in accordance with Eq 4, from the third set of handwheel readings for the sample and each of the bracketing reference fuels.

12.1.10.5 The cetane number calculated from the average of the second and third series of readings constitute a rating

providing that the difference between the cetane numbers calculated from the individual series is no greater than 1.4 CN.

12.1.10.6 If the second and third series of readings do not meet this criterion then the cause should be investigated.

12.1.10.7 If a sample is tested immediately following one for which the Reference Fuel No. 2 will be applicable, that reference fuel handwheel reading can be utilized for the new sample. The fuel switching shall thus be as illustrated in Fig. 3, Sample and Reference Fuel Reading Sequence B.

13. Calculation of Cetane Number

13.1 Using the values from two consecutive series of readings that are no greater than 1.4 CN apart, calculate the average handwheel readings for the sample and each of the reference fuel blends.

13.2 Calculate the cetane number by interpolation of these average handwheel readings proportioned to the cetane numbers of the bracketing reference fuel blends in accordance with Eq 4. See Fig. 4.

13.2.1 For the Handwheel Bracketing Procedure:

$$CN_S = CN_{LRF} + \left(\frac{HW_S - HW_{LRF}}{HW_{HRF} - HW_{LRF}} \right) (CN_{HRF} - CN_{LRF}) \quad (4)$$

where:

- CN_S = cetane number of sample,
- CN_{LRF} = cetane number of low reference fuel,
- CN_{HRF} = cetane number of high reference fuel,
- HW_S = handwheel reading of sample,
- HW_{LRF} = handwheel reading of low reference fuel, and
- HW_{HRF} = handwheel reading of high reference fuel.

13.2.2 If the cetane number of the sample is greater than the ARV of *T Fuel*, calculate the cetane numbers of the two Table 5 reference fuel blends that were used for the rating in accordance with Eq 5 and use these values in Eq 4.

$$\begin{aligned}
 CN_{RF} &= \{(\text{vol-}\% \text{ } T\text{Fuel} \cdot T\text{Fuel ARV}) \\
 &\quad + (\text{vol-}\% \text{ } n\text{-cetane} \cdot 100)\} / 100 \quad (5)
 \end{aligned}$$

TABLE 6 Cetane Number Repeatability and Reproducibility Limits

Average Cetane Number Level ^A	Repeatability Limits, Cetane Number	Reproducibility Limits Cetane Number
40	0.8	2.8
44	0.9	3.3
48	0.9	3.8
52	0.9	4.3
56	1.0	4.8

^A Values for cetane numbers intermediate to those listed above, may be obtained by linear interpolation.

13.2.3 Do not interpolate using reference fuel blend volume percent values and convert that equivalent percent to cetane number.

13.3 Round the calculated cetane number to the nearest tenth. Any cetane number ending in exactly 5 in the second decimal place shall be rounded to the nearest even tenth number; for example, round 35.55 and 35.65 to 35.6 cetane number.

14. Report

14.1 Report the calculated result as cetane number.

14.2 If the sample was filtered before testing, include this information in the report.

15. Precision and Bias⁹

15.1 *Handwheel Bracketing Procedure Precision*—The precision of this test method and procedure based on statistical examination of interlaboratory test results, all of which were obtained using secondary reference fuels, is as follows:

15.1.1 *Repeatability*—The difference between two test results, obtained on identical test samples under repeatability conditions would, in the long run, in the normal and correct operation of the test method, exceed the values in **Table 6** only in 1 case in 20.

15.1.2 *Reproducibility*—The difference between two single and independent results obtained on identical test samples under reproducibility conditions would, in the long run, in the normal and correct operation of the test method, exceed the values in **Table 6** only in 1 case in 20.

15.1.3 Repeatability precision limits are based on the ASTM National Exchange Group (NEG) monthly sample testing program data from mid-1978 through 1987. During this

period each exchange sample was rated twice on the same day by the same operator on one engine in each of the Member laboratories.

15.1.4 Reproducibility precision limits are based on the combined NEG monthly sample testing program data from mid-1978 through mid-1992, the Institute of Petroleum monthly sample data for 1988 through mid-1992 and the Institut Francais du Petrole monthly sample data for 1989 through early 1992.

15.1.5 The combination of the large number of sample sets and the fact that each sample is tested by 12 to 25 laboratories provides a comprehensive picture of the precision achievable using this test method. Analyzed graphically, the respective sample standard deviations were plotted versus cetane number. The variation in precision with respect to cetane number level for these data is best expressed by a linear regression of the values. The average standard deviation for each cetane number level has been multiplied by 2.772 to obtain the respective limit values.

15.1.5.1 The above precision estimates are based on test results predominantly obtained using the Mark II Ignition Delay Meter and its predecessor model, the Transistorized Ignition Delay Meter. No formal report comparing the precision obtained with the Dual Digital Cetane Meter (approved in 1990) to that of the earlier models is available.

15.1.6 An interlaboratory test program comparing the XCP Cetane Panel and the Dual Digital Cetane Meter showed no statistically observable difference in the precision of test results obtained with the two apparatus.¹⁰

15.2 *Bias*—The procedure in this test method for cetane number of diesel fuel oil has no bias because the value of cetane number can be defined only in terms of the test method.

15.2.1 An interlaboratory test program comparing the XCP Cetane Panel and the Dual Digital Cetane Meter showed a statistically observable bias between test results obtained with the two apparatus, the magnitude of which is less than the above repeatability estimates.¹⁰ The indicated bias is as follows:

$$\text{Dual Digital Cetane Number} = \text{XCP Panel Cetane Number} - 0.38$$

16. Keywords

16.1 cetane number; diesel performance; ignition delay

⁹ Supporting data (a listing of the data and the analyses used to establish the precision statements) have been filed at ASTM International Headquarters and may be obtained by requesting Research Report RR:D02-1303.

¹⁰ Supporting data have been filed at ASTM International Headquarters and may be obtained by requesting Research Report RR:D02-1798. Contact ASTM Customer Service at service@astm.org.

ANNEXES

(Mandatory Information)

A1. WARNING INFORMATION

A1.1 Introduction

A1.1.1 In the performance of the standard test method there are hazards to personnel. These are indicated in the text. For more detailed information regarding the hazards, refer to the appropriate Material Safety Data Sheet (MSDS) for each of the applicable substances to establish risks, proper handling, and safety precautions.

A1.2 Warning

A1.2.1 Combustible. Vapor harmful.

A1.2.2 *Applicable Substances:*

A1.2.2.1 Diesel fuel oil.

A1.2.2.2 Reference material.

A1.2.2.3 Reference fuel.

A1.2.2.4 *n*-cetane.

A1.2.2.5 Heptamethylnonane.

A1.2.2.6 Alpha-methylnaphthalene.

A1.2.2.7 Secondary reference fuels, *T Fuel* and *U Fuel*

A1.2.2.8 Check Fuel.

A1.2.2.9 Kerosine.

A1.2.2.10 Warm-up fuel.

A1.2.2.11 Engine crankcase lubricating oil.

A1.3 Warning

A1.3.1 Flammable. Vapors harmful if inhaled. Vapors may cause flash fire.

A1.3.2 *Applicable Substances:*

A1.3.2.1 Petroleum based solvent.

A1.4 Warning

A1.4.1 Poison. May be harmful or fatal if inhaled or swallowed.

A1.4.2 *Applicable Substances:*

A1.4.2.1 Ethylene glycol based antifreeze

A2. APPARATUS ASSEMBLY AND SETTING INSTRUCTIONS

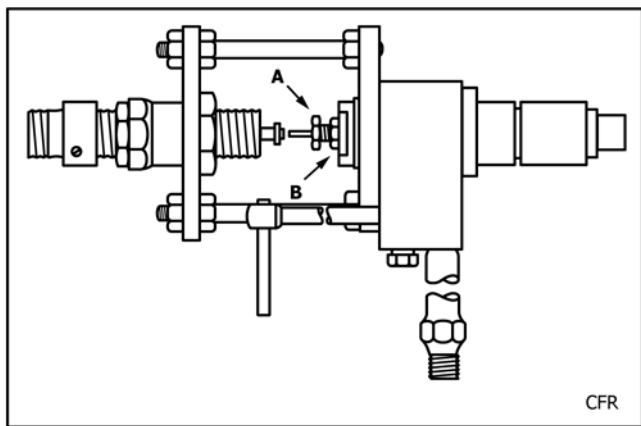

FIG. A2.1 Injector Assembly Showing Pickup Mounted

A2.1 Fuel Injector Nozzle Assembly Opening Pressure

Setting—Fuel injection occurs when the pressure in the nozzle assembly passages forces the nozzle pintle to lift against the force of an adjustable spring in the nozzle assembly. The setting should be checked each time the nozzle is disassembled and cleaned.

A2.1.1 To adjust the injection opening pressure, assemble the injector nozzle assembly in a suitable injector nozzle tester in a ventilated hood.

A2.1.2 Loosen the locknut B, Fig. A2.1 on the pressure

adjusting screw A and turn the adjusting screw as required to obtain the specified 10.3 MPa ± 0.34 MPa (1500 psi ± 50 psi) injection pressure. This is a trial and error procedure whereby the pressure is checked by use of the injector tester after each screw adjustment accompanied by relocking of the locknut B. Inspection for possible nozzle pintle drip as well as spray pattern should be observed when making this setting.

A2.1.3 After setting injection opening pressure, check that the injector pickup gap is typically 1 mm (0.040 in.) before reinstalling the injector assembly in the engine.

A2.2 *Checking Compression Pressure*—Determination of the compression pressure requires use of a compression pressure gauge assembly such as that illustrated in Fig. A2.2 readable to 2.5 psi and equipped with a suitable check valve and deflator or pressure release valve.

A2.2.1 Compression pressure is measured after the engine has been thoroughly warmed up on a typical diesel fuel oil under standard operating conditions for that fuel. The following steps should be performed as quickly as possible to ensure that the pressure readings represent hot engine conditions.

A2.2.2 Collect and have ready a calibrated compression pressure gauge assembly and the tools required to remove the combustion pickup and install the gauge assembly in the combustion chamber pickup hole.

A2.2.3 Shut the engine down by opening the injector assembly fuel bypass valve and then turning off the engine

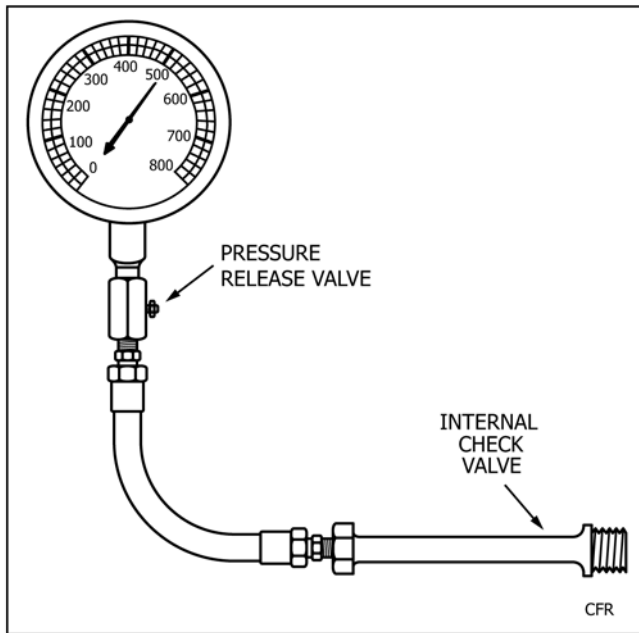

FIG. A2.2 Compression Pressure Gauge Assembly

A2.2.5 Remove the combustion pickup from the cylinder head and install the compression pressure gauge assembly. (**Warning**—Personnel shall avoid contact with the combustion pickup because it is extremely hot and can cause serious burns.)

A2.2.6 Set the handwheel to 1.000, regardless of the bore diameter of the cylinder in use.

A2.2.7 Restart the engine and operate in a motoring mode without any fuel being injected into the cylinder.

A2.2.8 Observe the compression pressure gauge reading, release the pressure once or twice using the deflator valve and record the equilibrium pressure which results. (**Warning**—In addition to other precautions, read the compression pressure gauge in whatever position it faces without twisting the gauge and hose which can distort the readings.)

A2.2.9 Satisfactory basic handwheel indexing is indicated if the compression pressure is $3275 \text{ kPa} \pm 138 \text{ kPa}$ ($475 \text{ psi} \pm 20 \text{ psi}$).

NOTE A2.1—Compression pressure values for engines operating at barometric pressures below 27 in. Hg have not been established.

A2.2.10 Shut the engine down, remove the compression pressure gauge assembly, reinstall the combustion pickup with a new gasket and tighten the pickup to the specified torque setting (30 lbf-ft).

power switch. The bypass valve must remain open for the remainder of the compression pressure check procedure.

A2.2.4 The fuel selector valve must be positioned so that fuel will continue to be delivered to the fuel pump to maintain proper pump barrel and plunger lubrication.

APPENDIXES

(Nonmandatory Information)

X1. VOLUMETRIC REFERENCE FUEL BLENDING APPARATUS AND PROCEDURES

X1.1 *Background*—Primary reference fuels which are used infrequently are usually packaged in relatively small containers and storage and dispensing is handled in the manner used for general chemicals. Secondary reference fuels are supplied in bulk containers of 5 U.S. gal or 55 U.S. gal capacity (0.019 m^3 or 0.208 m^3) and for laboratory safety reasons these bulk quantities are typically stored in a special fuel storage room or outside of the engine laboratory.

X1.2 *Delivery from Storage*—Delivery of reference fuel material from the bulk storage container to a dispensing apparatus in the engine laboratory may be handled in any of several ways. The equipment and procedures required for delivery of the reference fuel material are the responsibility of the user of this standard.

X1.3 *Dispensing Equipment*—A common means of accurately measuring reference fuel blend volumes applies a matched pair of calibrated glass burets, one for each of the two reference fuels. Fuel is dispensed either through an integral glass stopcock or a separate valve.

X1.3.1 Burets of glass with an automatic zero top fitting provide accurate, efficient and convenient measurement. A typical buret is illustrated in Fig. X1.1. Specifications for a typical buret are given in Table X1.1.

X1.3.2 *Separate Dispensing Valves*—It is common practice to utilize burets that do not have a dispensing stopcock. Bottom delivery from the buret is from a straight tubing bib which is connected by plastic tubing to a three-way valve similar to that shown in Fig. X1.2. The most important feature of such a valve assembly is the dispensing fitting which is formed so that only a very minimum of drip can occur if the collection container is inadvertently touched against the orifice tip. These valves can also be the means for controlling discharge flow rate to specification by use of the 6 mm ($\frac{3}{16}$ in. O.D.) tubing for the formed tip.

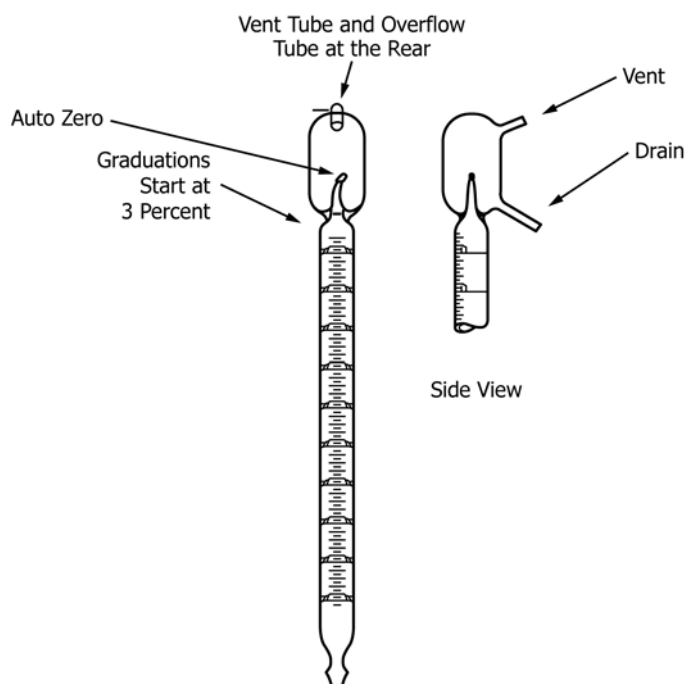

FIG. X1.1 Typical Reference Fuel Dispensing Buret

TABLE X1.1 Typical Buret Specifications

Buret Capacity	mL	500
Automatic Zero		YES
Graduations:		
Major Marks	%	5
Minor Marks	%	1
Internal Diameter of Graduated Tube:		
Minimum	mm	32
Maximum	mm	34
Scale Length, 5 to 100 %:		
Minimum	mm	523
Maximum	mm	591
Top of Overflow Bulb to 5 %	mm	100/120
Mark Length (nominal)		
Overall Length (including tip):		
Minimum	mm	650
Scale Error (Maximum)	%	0.1

X1.4 System Installation and Operation—User experience with reference fuel systems has pointed out a number of important aspects that support the following recommendations:

X1.4.1 Use amber glass burets for dispensing reference fuels or provide opaque shielding around all but the calibration mark area of clear glass burets.

X1.4.2 Mount burets vertically at an elevation that permits horizontal sighting of all calibration marks.

X1.4.3 Install a separate buret for each of the reference fuels.

X1.4.4 Mount burets in a manner that ensures freedom from vibration.

X1.4.5 Store bulk reference fuel containers and provide appropriate tubing for delivery of the fuels to the dispensing burets in accordance with the instructions of the manufacturer and in compliance with all local codes and regulations.

X1.4.5.1 Avoid the use of gravity flow delivery of reference fuel to burets.

X1.4.6 Thoroughly clean reference fuel burets on a regular basis to minimize hangup or clinging on the inner surface of the buret that can lead to blending errors.

X1.4.7 Burets should not be filled until a blend is required in order to minimize any tendency for deterioration of the fuel by exposure to light.

X1.4.8 Use stainless steel tubing, or other opaque tubing that does not react with reference fuel, to connect between the bulk reference fuel container and the dispensing buret.

X1.5 Procedure for Use of Buret System—To fill the buret, set the valve or stopcock to “fill” position, so that fuel rises in the buret until it overflows at the automatic zero. Stop filling by setting the valve to “off” position. Check that any bubbles are purged at the zero tip and refill the tip, if necessary.

X1.5.1 To dispense fuel, set the valve to “dispense” position, so that fuel is delivered to the collection container. Stop dispensing by setting the valve to “off” position while carefully noting the level of the fuel in the calibrated section of the buret and locating the bottom of the liquid meniscus at the desired volume percent mark.

X1.5.2 Before drawing a measured volume, make certain that the tip of the dispensing tube is full. When the measured volume has been collected, be certain not to drain any fuel from the tip of the dispensing tube as this will cause an error.

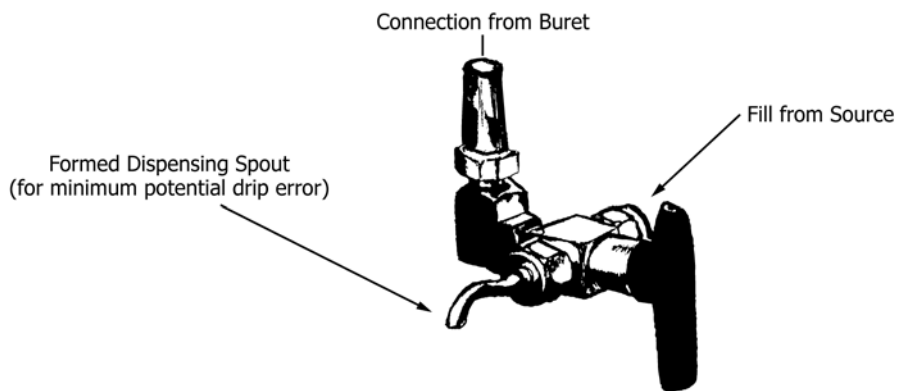

FIG. X1.2 Typical Fill/Dispense Valve

X2. OPERATING TECHNIQUES—ADJUSTMENT OF VARIABLES

X2.1 *Compression Ratio versus Handwheel Reading*—The compression ratio of the cetane engine is variable and depends upon the position of the variable compression plug in the precombustion chamber of the cylinder head. The variable compression plug is positioned by the screw action of the handwheel and the relative location of the plug is indicated by an indexed vernier scale. This handwheel reading scale extends from 0.500 to 3.000 and is inversely related to compression ratio. Low handwheel readings correspond to high compression ratio conditions while high handwheel readings reflect low compression ratio conditions.

X2.1.1 If the handwheel has been carefully indexed, the compression ratio of the cetane engine for any position of the variable compression plug can be calculated using the following equation:

$$CR = \frac{V_S + (V_{CC} + V_{TP} + V_{PU}) + V_{PC}}{(V_{CC} + V_{TP} + V_{PU}) + V_{PC}} \quad (X2.1)$$

where:

- CR = compression ratio,
- V_S = volume swept by piston in cylinder,
- V_{CC} = volume in main combustion chamber above piston at tdc including the valve recesses and piston top-land clearance,
- V_{TP} = volume of turbulence passage between combustion and pre-combustion chambers,
- V_{PU} = volume of threaded pickup hole with a pickup installed, and
- V_{PC} = volume of pre-combustion chamber.

X2.1.2 Volumes V_{CC} , V_{TP} , and V_{PU} are independent of cylinder bore diameter and are based on the physical dimensions of the cylinder head. The sum of these volumes is 0.659 cu. in. (10.8 cc) as determined by both calculation and measurement. The equation for compression ratio, when calculated using cu. in. units is thus:

$$CR = \frac{V_S + V_{PC} + 0.659}{V_{PC} + 0.659} \quad (X2.2)$$

X2.2 *Adjusting Compression Ratio Using the Handwheel*—Cetane method testing requires adjustment of compression

ratio (CR) to attain the proper ignition delay conditions for each specific diesel fuel oil or reference fuel. Changing handwheel setting changes the ignition delay period. Low cetane number fuels have inherently longer ignition delay characteristics than high cetane number fuels. The cetane method test procedure requires that all fuels operate at a specified ignition delay period and therefore changes in handwheel setting are necessary.

X2.2.1 Handwheel Adjustment Procedure:

X2.2.1.1 Loosen the small locking wheel of the handwheel assembly by counterclockwise rotation as viewed from the front of the engine. This releases the mechanism and permits the larger handwheel to be turned so that the variable compression plug can be properly moved in or out of the precombustion chamber.

X2.2.1.2 Set the larger handwheel to establish the required ignition delay period as indicated on the cetane meter. Clockwise rotation of the handwheel (viewed from in front of the engine) increases CR and decreases the ignition delay crank angle degree reading.

X2.2.1.3 Always make the final adjustment of the handwheel in the clockwise direction to minimize scale reading errors by eliminating the unavoidable play in the handwheel mechanism.

X2.2.1.4 Lock the mechanism by turning the small locking wheel clockwise until tight. (**Warning**—Hand tightening of the locking wheel should be adequate if the handwheel mechanism is in proper working order. The need to use additional leverage to achieve a locked condition indicates a need for handwheel assembly maintenance.)

X2.3 *Fuel System Operation*—As illustrated in Fig. X2.1 the fuel system incorporates three fuel tanks each with a drain valve ahead of a selector valve. The selector valve is positioned to deliver fuel from a specific fuel tank by rotation of the valve to the mark for that tank. The selected fuel is delivered to the fuel pump inlet and fills the fuel sump or gallery. The pump gallery also connects to the flow-rate buret through an air trap which is fitted with a drain valve. The fuel level in the buret will be the same as that in the fuel tank. When the selector

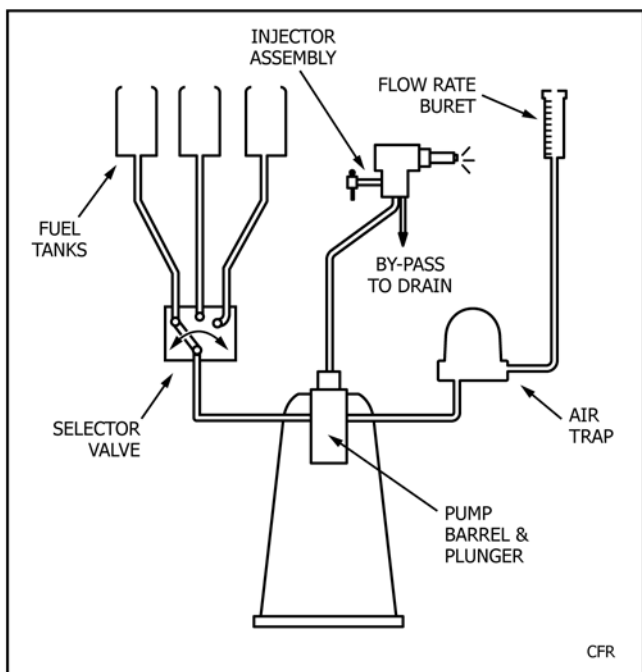

FIG. X2.1 Fuel System Schematic

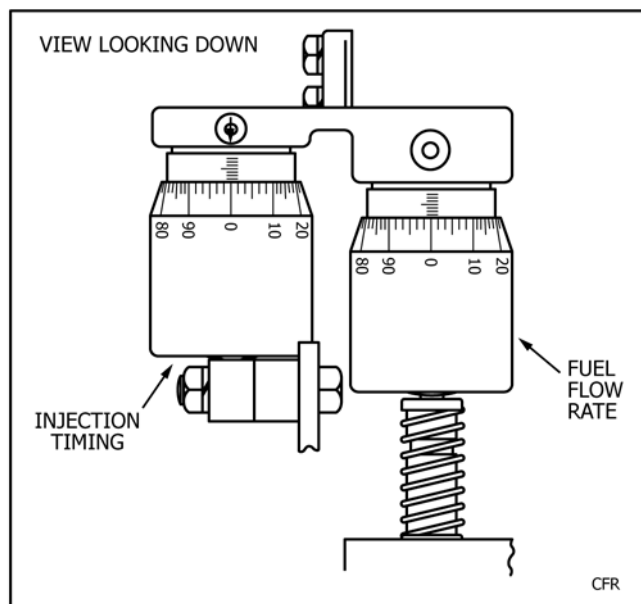

FIG. X2.2 Fuel Pump Flow Rate and Injection Timing Micrometers

valve is positioned so that the pointer is indexed between the fuel tank marks, fuel delivery from the tank is blocked. In this mode, the engine will continue to operate on the fuel which is in the gallery and the line from the flow rate buret. Fuel flow rate measurement can thus be performed by first filling the flow rate buret from the tank with the selector valve positioned on the tank mark and then positioning the valve between tank marks so that fuel from the buret leg alone supplies the fuel pump.

X2.3.1 The fuel flow-rate-buret is mounted so that the vent hole at the top of the buret is slightly above the level of the top of the fuel tanks thus preventing fuel overflow from the buret when the tank is full. The calibration marks on the buret are in 1 mL increments so that fuel flow rate is easily measured by noting the time required for engine consumption to lower the buret fuel level by a specific number of mL.

X2.3.2 *Changing to a New Fuel*—Introduction of a diesel fuel oil involves filling a fuel tank, purging the flow-rate-buret and air trap leg and displacement of the fuel in the fuel line from the pump to the injector assembly. (**Warning**—Diesel Fuel Oil—Combustible. Vapor harmful. See Annex A1.) The typical sequence for this process is as follows:

X2.3.2.1 Check that there is sufficient fuel in the buret leg to operate the engine while filling a tank with a new fuel. (**Warning**—Do not allow the fuel pump to run dry, except during the momentary periods required to switch from one fuel to another, because the fuel pump is partly dependent on fuel for lubrication.)

X2.3.2.2 Position the selector-valve so that it is between marks but adjacent to the mark for the fuel tank into which the new fuel is to be introduced.

X2.3.2.3 Check that the selected fuel tank is empty by opening the tank drain valve.

X2.3.2.4 Introduce the fuel to the fuel tank while leaving the associated drain valve open for an instant; then alternately close and open the valve a few times to remove any entrained air from the passages before finally closing the drain valve.

X2.3.2.5 In a series of quick steps, drain the buret leg, position the selector-valve to introduce the new fuel and when fuel begins to appear in the buret, position the selector-valve to between marks so the engine operates from the buret alone. This step purges the fuel system with the exception of the line from the pump to the injector. When the engine runs out of fuel, repeat the purging sequence. Engine operation on the purge sequences will afford sufficient time to completely displace the fuel in the line from the injection pump to the injector.

NOTE X2.1—Diesel fuel oils which are highly viscous or cause discoloring of the flow-rate-buret, may require more drastic flushing action for adequate purging.

X2.3.3 *Measuring Fuel Flow Rate:*

X2.3.3.1 Fill the flow-rate-buret and turn the selector-valve to between the marks.

X2.3.3.2 Using an electric stop clock (or stop watch), measure the fuel consumption by starting the clock as the meniscus passes a millilitre graduation on the buret and stopping the clock as the meniscus passes the mark selected for the amount of fuel to be consumed (typically 13 mL below the starting mark). Turn the fuel-selector-valve back to the mark to again draw fuel from the appropriate tank.

X2.3.3.3 If the time registered by the clock is not correct ($60\text{ s} \pm 1\text{ s}$ for 13 mL), readjust the fuel flow-rate-micrometer to change the pump rack position and thereby the amount of fuel being injected to the engine (see Fig. X2.2). Turn the flow rate micrometer clockwise (as viewed from in front of the engine) to increase fuel flow (shorten the clock time per unit volume). Typically, $0.005\text{ }\mu\text{m}$ divisions will cause a change of 1 s for 13 mL of fuel consumption.

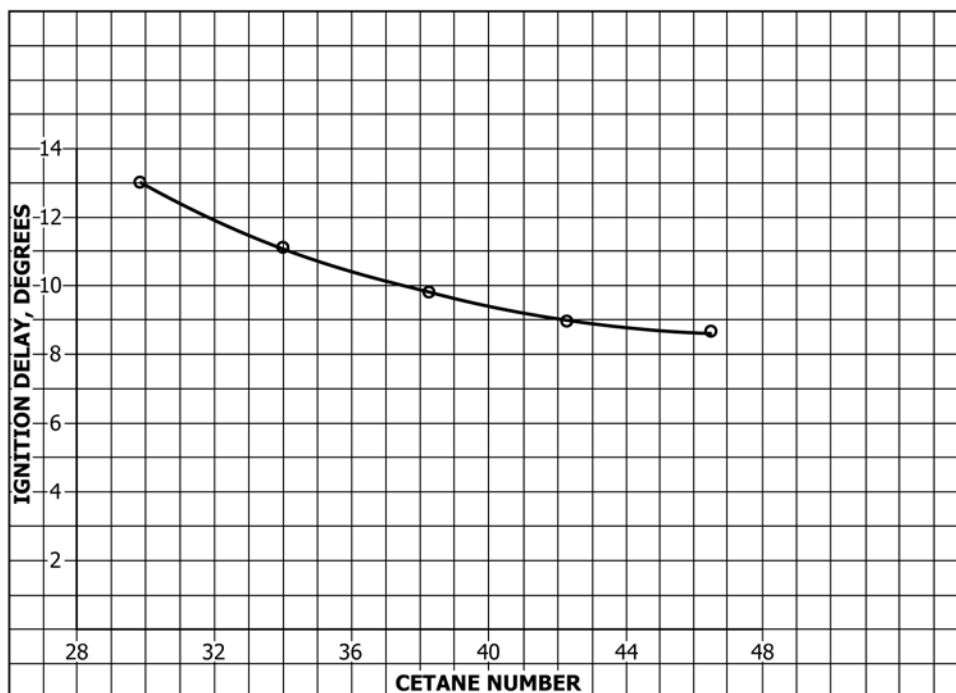

FIG. X2.3 Ignition Delay versus Cetane Number Characteristic

X2.3.3.4 Repeat the flow rate measurement procedure until the specified fuel flow rate is achieved.

X2.3.3.5 When the fuel level in the fuel tank lowers, the level in the flow-rate-buret may not be adequate to permit good flow rate measurement. In this case, use a suction bulb applied to the top vent hole of the buret and with the selector-valve positioned on the tank mark, pull fuel up from the pump gallery to the desired level. Before removing the suction bulb, quickly move the selector-valve to a position between the tank marks. Flow rate measurement must then be started almost immediately because the engine will be drawing fuel from the buret and the level in the buret will be falling.

X2.3.3.6 Determination of the proper flow rate is a trial and error procedure. Initial checks may be made using a 10 s time interval which should result in consumption of approximately 2 mL of fuel. The final flow rate measurement shall be made over a full $60 \text{ s} \pm 1 \text{ s}$ period.

X2.3.4 *Adjusting Fuel Injection Timing*—While operating the engine at the proper fuel flow rate and with the fuel-selector-valve positioned on the mark for the fuel being evaluated, observe the indicated injection timing (injection advance) value. Adjust the fuel injection timing micrometer to achieve the specified injection advance degrees (see Fig. X2.2). Turn the injection timing micrometer clockwise (as viewed from in front of the engine) to decrease the indicated number of degrees of advance.

X2.4 *Checking Ignition Delay versus Cetane Number Sensitivity*—The sensitivity characteristic illustrated in

Fig. X2.3 can provide a measure of confidence that the injector assembly and particularly the injector nozzle are performing in a satisfactory manner. It is a test that requires approximately 1 h to perform but it is useful to judge nozzle acceptance when engine instability has been experienced after cleaning and resetting.

X2.4.1 Using a reference fuel blend of approximately 35 cetane number, adjust all engine variables to standard operating conditions with the ignition delay period carefully set to 13.0° .

X2.4.2 Prepare a series of at least four more reference fuel blends of higher cetane number so that there is a difference of about 4 cetane numbers between each successive pair of blends.

X2.4.3 Operate the engine on each successive blend without changing the handwheel reading established for the 35 cetane number blend but adjusting the fuel flow rate to 13 mL/min and the injection timing to 13° . Record the resulting ignition delay values for each of the reference fuel blends.

X2.4.4 Plot the data on a graph similar to that in Fig. X2.3 so that the sensitivity characteristic can be observed. If the points do not fit an easily defined smooth curve, the injector nozzle is probably suspect and may require further cleaning maintenance or replacement. If a nozzle is faulty, it is often easily noted by the erratic operation and data scatter of the results obtained during the early stages of this procedure.

SUMMARY OF CHANGES

Subcommittee D02.01 has identified the location of selected changes to this standard since the last issue (D613 – 17a^{e1}) that may impact the use of this standard. (Approved June 1, 2017.)

(1) Added new subsection **8.4.4**.

Subcommittee D02.01 has identified the location of selected changes to this standard since the last issue (D613 – 17) that may impact the use of this standard. (Approved May 1, 2017.)

(1) Revised **Table 3**.

(2) Revised subsections **8.4.1** and **8.4.2**; revised Footnote 8.

Subcommittee D02.01 has identified the location of selected changes to this standard since the last issue (D613 – 16a) that may impact the use of this standard. (Approved March 1, 2017.)

(1) Added Test Method **D3703** to Referenced Documents.

(3) Revised subsections **3.2.2**, **8.3.1**, **8.3.2**, **8.5**, **8.5.1**, and **8.5.2**.

(2) Added new **Table 2** and **Table 3**.

Subcommittee D02.01 has identified the location of selected changes to this standard since the last issue (D613 – 16^{e1}) that may impact the use of this standard. (Approved Oct. 1, 2016.)

(1) Revised subsection **8.2**.

Subcommittee D02.01 has identified the location of selected changes to this standard since the last issue (D613 – 15a^{e1}) that may impact the use of this standard. (Approved June 1, 2016.)

(1) Added Practice **D6299** to Referenced Documents.

(3) Added new subsection **11.3** and subsequent sections.

(2) Added new term, *quality control (QC) sample*, to Terminology.

ASTM International takes no position respecting the validity of any patent rights asserted in connection with any item mentioned in this standard. Users of this standard are expressly advised that determination of the validity of any such patent rights, and the risk of infringement of such rights, are entirely their own responsibility.

This standard is subject to revision at any time by the responsible technical committee and must be reviewed every five years and if not revised, either reapproved or withdrawn. Your comments are invited either for revision of this standard or for additional standards and should be addressed to ASTM International Headquarters. Your comments will receive careful consideration at a meeting of the responsible technical committee, which you may attend. If you feel that your comments have not received a fair hearing you should make your views known to the ASTM Committee on Standards, at the address shown below.

This standard is copyrighted by ASTM International, 100 Barr Harbor Drive, PO Box C700, West Conshohocken, PA 19428-2959, United States. Individual reprints (single or multiple copies) of this standard may be obtained by contacting ASTM at the above address or at 610-832-9585 (phone), 610-832-9555 (fax), or service@astm.org (e-mail); or through the ASTM website (www.astm.org). Permission rights to photocopy the standard may also be secured from the Copyright Clearance Center, 222 Rosewood Drive, Danvers, MA 01923, Tel: (978) 646-2600; http://www.copyright.com/