



Standard Test Method for Shear Testing of Bulk Solids Using the Jenike Shear Tester¹

This standard is issued under the fixed designation D6128; the number immediately following the designation indicates the year of original adoption or, in the case of revision, the year of last revision. A number in parentheses indicates the year of last reapproval. A superscript epsilon (ϵ) indicates an editorial change since the last revision or reapproval.

1. Scope*

1.1 This method ²covers the apparatus and procedures for measuring the cohesive strength of bulk solids during both continuous flow and after storage at rest. In addition, measurements of internal friction, bulk density, and wall friction on various wall surfaces are included.

1.2 This standard is not applicable to testing bulk solids that do not reach the steady state requirement within the travel limit of the shear cell. It is difficult to classify ahead of time which bulk solids cannot be tested, but one example may be those consisting of highly elastic particles.

1.3 The most common use of this information is in the design of storage bins and hoppers to prevent flow stoppages due to arching and ratholing, including the slope and smoothness of hopper walls to provide mass flow. Parameters for structural design of such equipment also may be derived from this data.

1.4 All observed and calculated values shall conform to the guidelines for significant digits and rounding established in Practice [D6026](#).

1.4.1 The procedures used to specify how data are collected/recorded or calculated, in this standard are regarded as the industry standard. In addition, they are representative of the significant digits that generally should be retained. The procedures used do not consider material variation, purpose for obtaining the data, special purpose studies, or any considerations for the user's objectives; and it is common practice to increase or reduce significant digits of reported data to be commensurate with these considerations. It is beyond the scope of this standard to consider significant digits used in analysis methods for engineering design.

¹ This testing method is under the jurisdiction of ASTM Committee [D18](#) on Soil and Rock and is the direct responsibility of Subcommittee [D18.24](#) on Characterization and Handling of Powders and Bulk Solids.

Current edition approved Feb. 1, 2016. Published March 2016. Originally approved in 1997. Last previous edition approved in 2014 as D6128 – 14. DOI: 10.1520/D6128-14.

² This test method is based on the "Standard Shear Testing Technique for Particulate Solids Using the Jenike Shear Cell," a report of the EFCE Working Party on the Mechanics of Particulate Solids. Copyright is held by the Institution of Chemical Engineers and the European Federation of Chemical Engineering.

1.5 *Units*—The values stated in SI units are to be regarded as standard. No other units of measure are included in this standard

1.6 *This standard does not purport to address all of the safety concerns, if any, associated with its use. It is the responsibility of the user of this standard to establish appropriate safety and health practices and determine the applicability of regulatory limitations prior to use.*

2. Referenced Documents

2.1 ASTM Standards:³

[D653 Terminology Relating to Soil, Rock, and Contained Fluids](#)

[D2216 Test Methods for Laboratory Determination of Water \(Moisture\) Content of Soil and Rock by Mass](#)

[D3740 Practice for Minimum Requirements for Agencies Engaged in Testing and/or Inspection of Soil and Rock as Used in Engineering Design and Construction](#)

[D4753 Guide for Evaluating, Selecting, and Specifying Balances and Standard Masses for Use in Soil, Rock, and Construction Materials Testing](#)

[D6026 Practice for Using Significant Digits in Geotechnical Data](#)

3. Terminology

3.1 *Definitions*—For common definitions of technical terms in this standard, refer to Terminology [D653](#).

4. Summary of Test Method

4.1 A representative specimen of bulk solid is placed in a shear cell of specific dimensions. This specimen is preconsolidated by twisting the shear cell cover while applying a compressive load normal to the cover.

4.2 When running an instantaneous or time shear test, a normal load is applied to the cover, and the specimen is presheared until a steady state shear value has been reached.

4.3 An instantaneous test is run by shearing the specimen under a reduced normal load until the shear force goes through a maximum value and then begins to decrease.

³ For referenced ASTM standards, visit the ASTM website, www.astm.org, or contact ASTM Customer Service at service@astm.org. For *Annual Book of ASTM Standards* volume information, refer to the standard's Document Summary page on the ASTM website.

*A Summary of Changes section appears at the end of this standard

4.4 A time shear test is run similarly to an instantaneous shear test, except that the specimen is placed in a consolidation bench between preshear and shear.

4.5 A wall friction test is run by sliding the specimen over a coupon of wall material and measuring the frictional resistance as a function of normal, compressive load.

4.6 A wall friction time test involves sliding the specimen over the coupon of wall material, leaving the load on the specimen for a predetermined period of time, then sliding it again to see if the shearing force has increased.

5. Significance and Use

5.1 Reliable, controlled flow of bulk solids from bins and hoppers is essential in almost every industrial facility. Unfortunately, flow stoppages due to arching and ratholing are common. Additional problems include uncontrolled flow (flooding) of powders, segregation of particle mixtures, useable capacity which is significantly less than design capacity, caking and spoilage of bulk solids in stagnant zones, and structural failures.

5.2 By measuring the flow properties of bulk solids, and designing bins and hoppers based on these flow properties, most flow problems can be prevented or eliminated.

5.3 For bulk solids with a significant percentage of particles (typically, one third or more) finer than about 6 mm, the cohesive strength is governed by the fines (-6-mm fraction). For such bulk solids, cohesive strength and wall friction tests may be performed on the fine fraction only.

NOTE 1—The quality of the result produced by this test method is dependent on the competence of the personnel performing it, and the suitability of the equipment and facilities used. Agencies that meet the criteria of Practice D3740 are generally considered capable of competent and objective testing/sampling/inspection/etc. Users of this test method are cautioned that compliance with Practice D3740 does not in itself assure reliable results. Reliable results depend on many factors; Practice D3740 provides a means of evaluating some of those factors. Practice D3740 was developed for agencies engaged in the testing and/or inspection of soil and rock. As such it is not totally applicable to agencies performing this test method. However, users of this test method should recognize that the framework of Practice D3740 is appropriate for evaluating the quality of an agency performing this test method. Currently there is no known qualifying national authority that inspects agencies that perform this test method.

6. Apparatus

6.1 The Jenike shear cell is shown in Fig. 1. It consists of a base (1), shear ring (2), and shear lid (3), the latter having a bracket (4) and pin (5). Before shear, the ring is placed in an offset position as shown in Fig. 1, and a vertical force F_v is applied to the lid, and hence, to the particulate solid within the cell by means of a weight hanger (6) and weights (7). A horizontal force is applied to the bracket by a mechanically driven measuring stem (8).

6.2 It is especially important that the shear force-measuring stem acts on the bracket in the shear plane (plane between base and shear ring) and not above or below this plane.

6.3 The dimensions of the Jenike shear cells that have in the past been supplied by Jenike & Johanson, Inc. are given in the first two columns of the table in Fig. 4. These dimensions have been derived from English units. The standard size Jenike shear cell is made from aluminum or stainless steel, and a smaller 63-mm diameter cell made from stainless steel is also available. Since the actual dimensions are not believed to be critical, the same results could be obtained with a shear cell of the dimensions listed in the third column of the table in Fig. 4 or with other shear cells of different sizes provided that proportions of these dimensions are maintained approximately. In addition, the shear cell diameter must be at least 20 times the maximum particle size of the bulk solid being tested.

6.4 Besides the shear cell, the complete shear tester includes a force transducer, which is capable of measuring the shear force F_s , up to 500 N with a precision of 0.1 % of full scale, an amplifier to condition the signal from the force transducer and a recorder, a motor driving the force-measuring stem capable of advancing the stem at a constant speed in the range from 1 to 3 mm/min, a twisting wrench, a weight hanger, a time consolidation bench, an accessory for mounting wall material test plates, and a calibrating device. A spatula having a blade at least 50 % longer than the diameter of the shear cell, and at least a 10-mm width, is needed.

NOTE 2—The original Jenike shear tester has a speed of 2.72 mm/min when the power supply is 60 Hz.

6.5 As an alternative to the twisting wrench, some shear testers are supplied with a twisting device in which the twist is

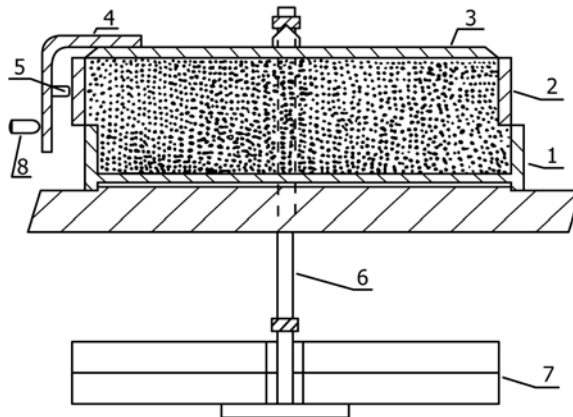

FIG. 1 Jenike Cell in Initial Offset Position

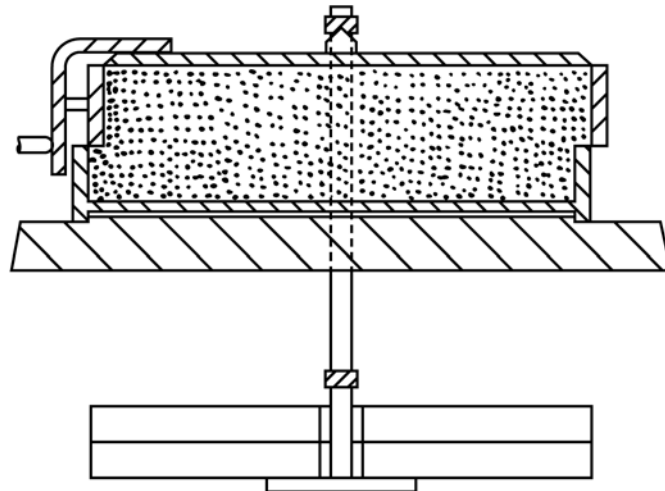

FIG. 2 Jenike Cell in Final Offset Position

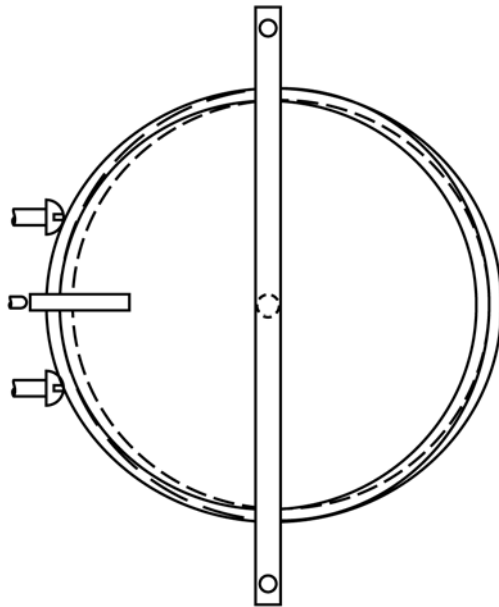

FIG. 3 Plan View of Jenike Cell Showing Offset

Several coupons of typical wall materials should be available. When using the standard size shear cell, each coupon should be approximately 120 mm × 120 mm.

6.8 A device for calibrating the force transducer is shown in Fig. 7. It consists of a pivot (1) around which levers of equal length, (2) and (3) rotate. With counterweight (4) the device is balanced to have its neutral position as shown in the figure. Lever (2) exerts a force to the force-measuring stem corresponding to the weights (5) which are hung on the lever (3). The calibration curve is used to convert the recorder reading to the applied shear force.

6.9 A laboratory balance having a maximum capacity of at least 1 kg with a precision of 1 % or better is required.

7. Specimen Preparation

7.1 The laboratory used for powder testing should be free of vibrations caused by traffic or heavy machinery. Ideally, the room should be temperature and humidity controlled, or, if this is not possible, it should be maintained at its nearly constant ambient conditions. Direct sunlight, especially on the time consolidation bench, is to be avoided.

NOTE 3—Temperature- and humidity-sensitive materials may need to be tested at different temperatures and moisture contents, because this often happens in industrial environments. The laboratory environment must approximate production for meaningful testing.

7.2 Filling the Cell (Fig. 8):

7.2.1 Place the shear ring on the base in the offset position shown in Fig. 1 and gently press the ring with the fingers against the locating screws (10) as shown in Fig. 3 and Fig. 9. Set these screws to give an overlap of approximately 3 mm for standard cell sizes and to make sure that the axis of the cell is aligned with the force-measuring stem. Then place the mold ring (11) on the shear ring.

7.2.2 Fill the assembled cell uniformly in small horizontal layers by a spoon or spatula without applying force to the surface of the material until the material is somewhat over the top of the mold ring. The filling should be conducted in such a way as to make sure that there are no voids within the cell, particularly at “a” (Fig. 8) where the ring and the base overlap.

applied by means of a shaft passing through bearings. In this way, the likelihood of nonvertical forces or extra forces being generated during twisting is minimized. Another alternative is to have the motor pull the force-measuring stem instead of pushing it. When using any such alternative methods, it is essential that the user make sure that no measurement deviations are introduced.

6.6 The consolidation bench consists of several stations for time consolidation tests. One station is shown in Fig. 5. The station is equipped with a weight carrier (14) on which the weights may be placed and a flexible cover (15) to constrain the test cell and prevent any influence from environmental effects such as evaporation or humidification during time consolidation.

6.7 The arrangement for wall friction tests is shown in Fig. 6. For these tests it is convenient to have a special shear lid with a longer pin and bracket to permit a longer shear distance.

	JENIKE STANDARD	JENIKE SMALL SIZE	STANDARD SIZE
D/mm	95.25	63.5	95
H _b /mm	12.7	9.525	13
H _r /mm	15.875	11.113	16
H _m /mm	9.525	7.938	10
T/mm	3 or greater	3 or greater	3 or greater
Material	Stainless Steel or Aluminum	Aluminum	Stainless Steel or Aluminum

GROOVES: 1 mm wide, 90° Included angle

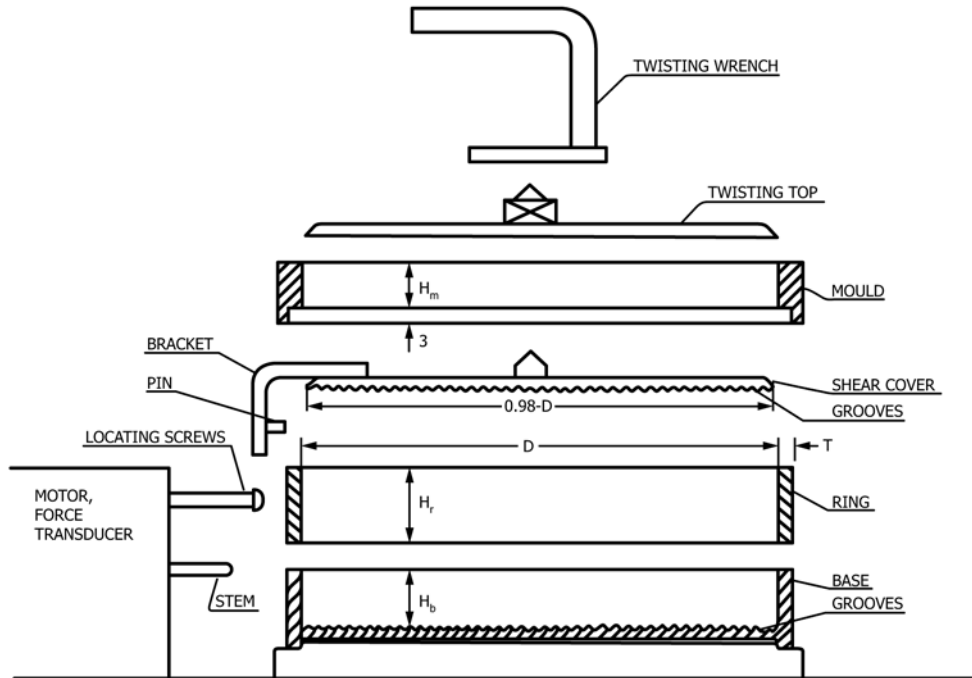

FIG. 4 Dimensions of the Jenike Cell

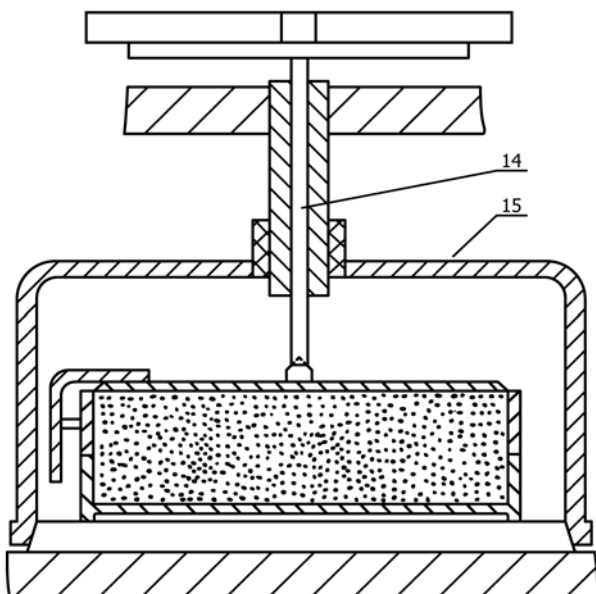

FIG. 5 Consolidating Bench Station

Remove excess material in small quantities by scraping off with a blade (1). The blade should be scraped across the ring in a zig-zag motion. Take care not to disturb the position of the ring on the base. For scraping, a rigid sharp straight blade should be used, and, during scraping, the blade should be tilted as shown in Fig. 8.

7.3 Preconsolidation:

7.3.1 Place the twisting or consolidation lid (12) shown in Fig. 9 on the leveled surface of the material in the mold, then place the hanger (6) on the twisting lid with weights (7) of mass m_{Wrv} being hung from the hanger. See Fig. 1. Lower the lid, hanger, and weights as slowly as possible to minimize aerated material being ejected from the cell.

7.3.2 Visually observe the vertical movement of the lid as the material of the cell is compressed. Wait until this movement appears to stop.

7.3.3 Remove the weights, hanger, and twisting lid. Fill and level the space above the compressed material as during filling.

NOTE 4—As will be mentioned later, this refilling procedure may not be necessary at all or may need to be performed several times, depending on

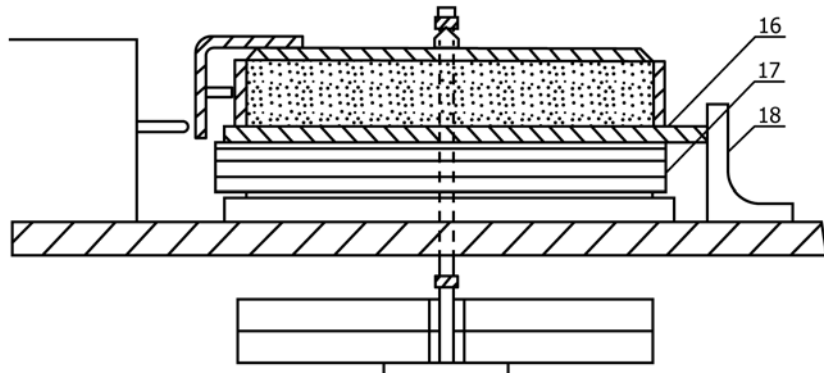

FIG. 6 Wall Friction Test

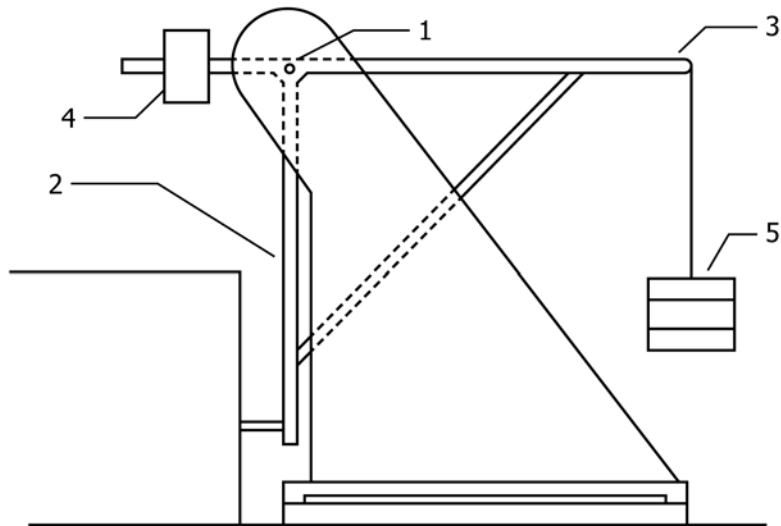

FIG. 7 Calibration Device

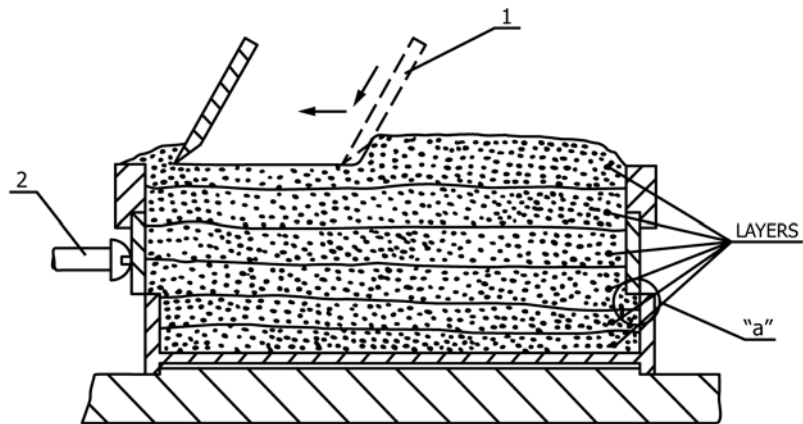

FIG. 8 Scraping Off Excess Powder

the compressibility of the powder being tested. This operation determines what height of compacted material will have to be scraped off the ring after twisting.

7.4 *Twisting:*

7.4.1 Place the twisting lid (12) with a smooth bottom surface on the leveled surface of material in the mold after filling or refilling. Place the hanger with weights of m_{Wtw} on the

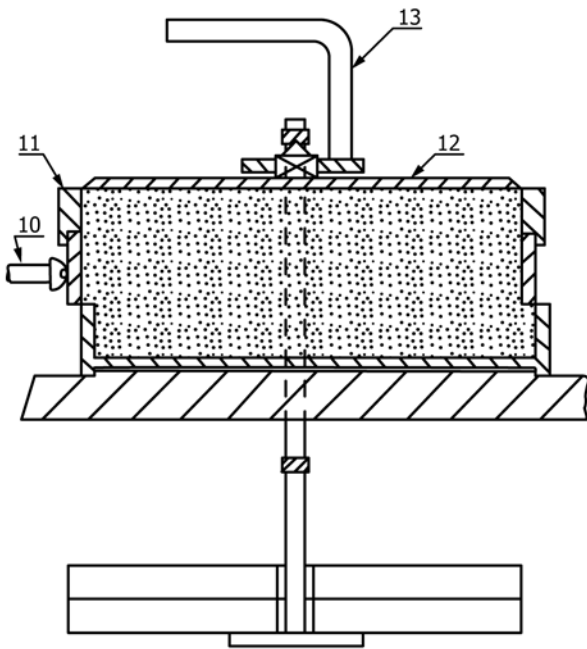

FIG. 9 Jenike Cell With Mold Ring and Consolidation Lid

twisting lid. The weights on the hanger should correspond to a pressure of σ_{tw} , approximately equal to σ_p .

7.4.2 Empty the cell and repeat the filling operation if the surface of material in the cell does not appear to the naked eye to be level.

7.4.3 Having filled the cell, the twisting lid is usually twisted through 20 cycles by means of the twisting wrench (spanner) (13) or twisting device. The twisting is performed by holding the wrench in one hand and using the thumb and forefinger of the other to maintain the ring in the offset position against the locating screws (2) shown in Fig. 8. The twisting operation should be smooth and continuous, without jerks, and at the rate of about one twist per second. Each twisting cycle consists of a 90° rotation of the lid which is then reversed. It is useful to mark the shear cell or twisting device to make sure of a 90° rotation. Care must be taken not to apply vertical forces to the lid during twisting. While twisting, press the ring against the locating screws with the fingers to prevent it from sliding from its original offset position.

7.4.3.1 The mold and ring should be allowed to rotate freely and independently of each other. The rotation of the ring may be small but has an influence on the consolidation.

7.4.4 After twisting, carefully remove the weights and hanger, then hold the lid in position by light finger pressure and carefully remove the mold. Slide the lid off the material in the cell, sliding it in the direction of the force-measuring stem so that the shear ring is kept pressed in position against the locating screws.

7.4.4.1 The compacted material above the ring should be evenly distributed if the filling has been satisfactory. The material remaining above the ring after twisting should be from 1 to about 3 mm thick.

7.4.5 Discard the test specimen and prepare a new one if, after twisting, the material surface is below the top of the ring.

7.4.6 Scrape off excess material in small quantities to be flush with the top of the ring using a blade in the same way as that shown in Fig. 8. Do not exert downward force by the scraping blade.

7.4.6.1 If coarse particles are present, scraping may tear them from the surface and alter the structure. In such cases, it is better to attempt to fill the cell so that the material surface is flush with the ring after consolidation. Care must again be taken not to displace the shear ring from its original offset position.

7.5 Bulk Density:

7.5.1 A preliminary estimate of the bulk density can be made by placing the shear ring on a flat surface, packing the particulate solid in the ring with fingers, scraping the solid level with the top, and weighing the contained solid. From the masses and volume of the specimen, calculate the bulk density.

7.6 Wall Friction:

7.6.1 When measuring the friction between the particulate solid and a coupon of silo wall material in a wall friction test, replace the base of the shear cell by the coupon of wall material. Shear the specimen contained in the upper part of the shear cell (the ring and shear lid) over the wall material coupon under different wall normal stresses σ_w and measure the resulting wall shear stresses τ_w .

7.6.2 *Selection of Wall Friction Normal Stress Levels*—Select six wall friction normal stress levels, σ_{w1} to σ_{w6} , where σ_{w1} is the smallest normal stress. The largest normal stress, σ_{w6} , should be approximately equal to the major consolidation stress, $\sigma_{1,2}$, of the second preshear normal stress, $\sigma_{p,2}$. The smallest normal stress σ_{w1} will normally include the hanger without weights.

7.6.3 Wall Coupon and Material Specimen Preparation:

7.6.3.1 Wash the wall material coupon and dry thoroughly before the test. Do not touch the surface after washing by the bare hands.

7.6.3.2 Shim (17) the wall coupons (16) (see Fig. 6) so that the top surface of the coupon is the horizontal plane of the force-measuring stem. Place the ring on the wall coupon and set it against the locating screws. Adjust the position of the wall coupon so that it just covers the inside of the shear ring on the stem side and permits maximum travel of the ring over the coupon during the test. Fix the position of the wall coupon (18) (see Fig. 6).

7.6.3.3 Place the mold ring on the shear ring, and fill the shear ring and mold ring with the particulate solid. Scrape excess material flush with the top of the mold ring.

7.6.3.4 Place the twisting lid on the leveled material, place the hanger on the lid, and place weights on the hanger, corresponding to the normal stress, σ_{w6} . Using the twisting wrench, twist the lid to homogenize the specimen. Do not apply vertical stress to the twisting lid by the twisting wrench. During twisting allow the mold ring and the shear ring to rotate. After consolidation, carefully remove the weight hanger and weights from the twisting lid. Hold the twisting lid down lightly with the fingers and remove the mold ring. Carefully remove the twisting lid from the cell by sliding towards the locating screws, and scrape off the caked material level with

the top of the shear ring. Observe the same procedure and precautions as for preparation of a specimen for shear testing.

7.6.3.5 If after consolidation, the level of the compressed material is below the top of the shear ring, refill the cell as previously described prior to removing the mold ring.

7.6.3.6 Place the shear lid on the levelled material in the shear ring, aligning the lid with the shear unit stem. Twist and manually lift the ring slightly off the wall material coupon to prevent it from dragging on the wall coupon.

7.6.3.7 Rub the particulate solid under test onto the surface of the wall coupon by applying pressure less than or equal to σ_{w6} by hand to the lid, and sliding the solid across the wall coupon by hand, away from the shear unit stem. Release the pressure and push the cell back to the starting position. Repeat twice.

8. Procedure

8.1 *Shear Testing Procedure for Instantaneous Shear Test:*

8.1.1 *Preshear:*

8.1.1.1 The first part of the shear test consists of preparing a critically consolidated specimen by optimized twisting and then preshearing the specimen with a selected weight, m_{wp} , to develop a shear zone in which steady state flow occurs.

8.1.1.2 Select the first preshear normal stress, $\sigma_{p,1}$, on the basis of the bulk density of the test material, in accordance with the following table:

ρ_b (kg/m ³)	$\sigma_{p,1}$ (kPa)
< 300	approximately 1.5
300 to 800	approximately 2.0
800 to 1600	approximately 2.5
1600 to 2400	approximately 3.0
> 2400	approximately 4.0

8.1.1.3 Place the shearing lid centrally on the leveled surface of material with the pin of the bracket within 1 mm of the ring. Make sure that the bracket of the shear lid is in line with the force-measuring stem. Place weights m_{wp} correspond-

ing to σ_p on the hanger, and gently lower the hanger with weights as slowly as possible onto the shear lid so as to not jar the specimen. Steady the hanger to prevent any visible swinging motion. Switch on the motor driving the force-measuring stem.

8.1.1.4 At the selected preshear normal stress prepare a nearly critically consolidated specimen and start preshear. The shear stress rises (Fig. 10) and attains the steady state value τ_p . Maintain this shear stress in the shear cell through a relatively short shear distance (about 0.5 mm) to ascertain this value.

(1) The steady state shear stress τ_p may be attained after relatively little shear, even before the shear ring and base completely overlap. With some materials a greater amount of shear may be necessary to attain steady state shear. However, the steady state shear stress should be attained after a maximum shear distance corresponding to three fourths of the total available.

NOTE 5—The full shear distance of approximately 6 mm from the offset position in Fig. 1 to the offset position in Fig. 2 for standard cell sizes.

8.1.1.5 Record the shear force, F_s , for the whole shear distance.

NOTE 6—During shear, a shear zone develops in the specimen of particulate solid in the cell. Since the stem advances at a steady rate, the record of shear force versus time can be transformed into a shear force – shear strain plot.

8.1.1.6 Inspect the shear force – shear strain plot. If the specimen is found to be under-consolidated, or over-consolidated, remove the specimen and repeat the procedure beginning at 7.1. If the specimen is found to be under-consolidated, increase the number of twists applied to the lid, then increase the weight m_{wtw} in accordance with A3.10. If the specimen is over-consolidated, decrease the number of twists, then reduce the weight m_{wtw} in accordance with A3.11.

NOTE 7—In such a manner, it is possible by trial and error, to find a

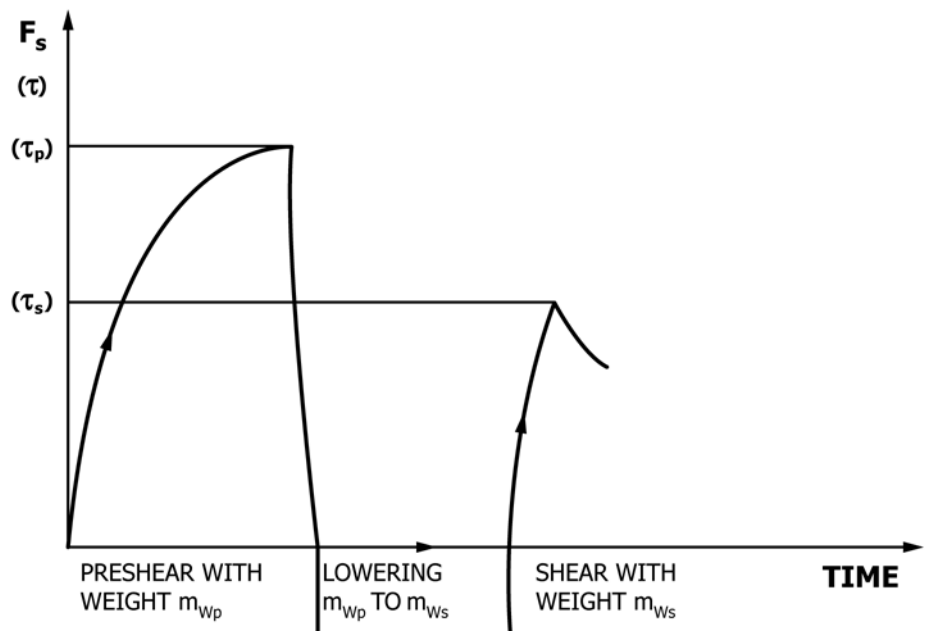

FIG. 10 Stress-Strain Curves — Preshear and Shear

combination of weight, m_{w_n} , and the number of twists so that for the selected weight, m_{w_p} , the shear force – shear strain plot indicates the presence of a critically consolidated specimen. This operation is called optimization. See **Annex A3**.

NOTE 8—Each shear test gives one point on a yield locus and consists of preshear and shear. Changes in the preconsolidation procedure may affect the yield locus derived from this test.

8.1.1.7 The force-measuring stem measures the shear force in the shear plane between the base and ring, and hence, the corresponding normal force has to be determined in this plane. In the Jenike shear cell this normal force, F_v , is a vertical force produced by the combined masses of:

- Weights, m_w
- Hanger, m_H
- Shear Lid, m_L
- Ring, m_R
- Material in the shear ring above the shear plane, m_B

NOTE 9—The shear ring is included in the vertical force since during shear the material dilates in the shear zone, as a result of which all material above the shear plane is lifted slightly. Since the material is constrained in the shear ring, any dilation of the cell contents brings about a lifting of the ring such that the weight of the ring is supported by the material in the ring rather than by the cell base. For preshear, this is not strictly so, because part of the weight of the ring may be transferred to the base. Therefore, because during preshear that portion of the weight of the ring transferred to the base is uncertain, the weight of the ring is included in the weights contributing towards the total normal force when calculating the preshear normal force. The influence of the ring-base contact on the shear and normal force can be avoided by carefully lifting the shear ring less than 1 mm and twisting it through a couple of degrees prior to shear while the shear lid has a weight applied to it.

8.1.1.8 Constancy of the values of the steady state shear stress τ_p obtained after preshear is an indication of the reproducibility of consolidation. With correctly consolidated specimens, individual values of the steady state shear stress should not deviate by more than $\pm 5\%$ from the average steady state shear stress for the given preshear normal stress. With some particulate solids, however, this tolerance cannot be achieved. If this happens, it should be noted by the technician performing the test.

8.1.2 Shear:

8.1.2.1 Having attained a steady state flow condition, reverse the forward motion of the force-measuring stem until the stem loses contact with the bracket, that is, the shear force falls to zero, (**Fig. 10**). For the second stage select a shear normal stress level σ_s within the range of 25 to 80 % of the preshear normal stress level σ_p , and replace the weight m_{w_p} by a smaller weight m_{w_s} . Switch on the motor again to drive the measuring stem in the forward direction.

(1) When the stem touches the bracket, the shear force rapidly increases, goes through a maximum representing the yield shear force, and then begins to decrease. This part of the test is called shear.

(2) Shear may be continued until the whole overlap distance of the cell has been traversed in order to develop a distinct shear plane. The value τ_s is the shear stress at failure peak (shear point) for the selected shear normal stress σ_s at the selected preshear normal stress σ_p .

(3) When reducing the normal stress before shear, it is recommended that weights be removed from the hanger until the required weight is left. If the test is to be carried out at low shear, and hence low normal stress levels, it may be necessary

to remove the hanger and place the weights directly on the lid. Whichever procedure is followed, the weights should be removed and replaced in a gentle manner.

8.1.2.2 After each shear test, calculate the overall bulk density of the specimen by determining the mass of the specimen with the base, shear ring, and shear lid.

(1) Since the mass of base, ring, and lid are known and also the volume of the cell can be determined, the overall bulk density, ρ_b , of the specimen can be calculated.

NOTE 10—The value of the bulk density of the specimen after the shear test gives an indication of the reproducibility of specimen preparation.

8.1.2.3 After each shear test (and weighing), lift the shear ring with shear lid and material contained within the ring from the base and inspect the plane of failure.

8.1.2.4 If the plane of failure cuts diagonally across the particulate solid either up to the shear lid or down to the bottom of the base, the test is invalid and will have to be repeated.

(1) If an invalid plane of failure persists, further tests at the given and lower shear normal stress levels cannot be performed and shear tests can be made only at higher shear normal stresses. In such a case, the intervals between the shear normal stress levels may have to be reduced to obtain the necessary minimum of three shear points on the yield locus.

NOTE 11—If the material is free flowing it may be impossible to observe the plane of failure.

8.1.3 Additional Tests:

8.1.3.1 Repeat **7**, **8.1.1** and **8.1.2**.

8.1.3.2 Select 3 to 5 shear normal stress levels σ_s within the range of 25 to 80 % of the preshear normal stress level σ_p , and repeat **7**, **8.1.1.4**, **8.1.2**, and **8.1.3.1**.

8.1.3.3 Select higher preshear normal stress levels so that:

$$\begin{aligned}\sigma_{p,2} &= 2\sigma_{p,1} \\ \sigma_{p,3} &= 4\sigma_{p,1} \\ \sigma_{p,4} &= 8\sigma_{p,1}\end{aligned}$$

(1) Some adjustment in preshear normal stress levels may be necessary in order to cover the range of major consolidation stresses σ_1 necessary to accurately calculate critical arching and/or ratholing dimensions.

8.1.3.4 Repeat **7**, **8.1.1**, **8.1.2**, and **8.1.3.2** for each selected preshear normal stress level.

8.2 Shear Testing Procedure for Time Consolidation:

8.2.1 When a particulate solid is exposed to a normal or compressive stress for some time it may gain strength. This gain in strength may be measured in the Jenike shear cell, and the effect is called time consolidation.

8.2.2 Time consolidation is carried out using a consolidating bench, which consists of several shear cells that can be loaded independently. The time that the specimens sit at rest is specified according to the application.

8.2.2.1 As an alternative to using a consolidation bench, consider the following: a critically consolidated specimen is prepared by preshearing with weight m_{w_p} . After attaining steady state flow the advance of the force-measuring stem is stopped but the stem is not retracted. The shear zone formed thus remains under the normal and shear stresses corresponding to steady state flow and is kept in this state for a definite

time, t . If the stem is then retracted, the shear force will drop to zero, and the actual shear test may be performed in the usual way.

NOTE 12—If the effect of time consolidation in the Jenike shear cell were measured in this manner, one test would monopolize the shear cell for a very long time. Also, creep of the specimen could cause a decrease in the applied shear force during the resting phase.

8.2.3 *Specimen preparation and preshear time effects*—After completion of instantaneous testing and evaluation, perform time tests at the same preshear normal stress levels.

NOTE 13—For a selected preshear normal stress, specimen preparation and preshear are the same as for the instantaneous test.

8.2.4 *Time Consolidation:*

8.2.4.1 Perform the test for time consolidation in the following way. Using the shear tester, prepare and preshear specimens with weight m_{wp} in the normal manner and then retract the stem after preshear. Remove the hanger with weights. Then transfer the shear cells (base, shear ring, shear lid, and material) to the consolidating bench. In order to prevent the evaporation or take up of moisture from the ambient environment, place a flexible cover over each cell, and then load each by placing a weight m_{wt} either directly on the lid or by means of a loading rod.

(1) When the shear cell is transferred from the shear tester to the consolidating bench, care should be taken that the ring is not moved relative to the base. As the weight carrier is lowered on the shear lid, great care must be taken in adjusting the position of the shear cell on the consolidation bench to make sure that the weight carrier acts centrally on the shear lid or on a similarly sized compression plate when the weight carrier is lowered.

8.2.4.2 Select the weight m_{wt} in such a way that the stress state in the specimen during time consolidation is the same as during preshear (that is, steady state flow).

(1) The Mohr circle shown in Fig. 11 is drawn through

Point P (steady state flow) and is tangential to the yield locus. During time consolidation, the specimen is loaded with the major principal stress, σ_1 , of that Mohr circle as shown in Fig. 11.

NOTE 14—During preshear a normal stress as well as a shear stress is acting, although on the consolidating bench only normal stresses can be applied. Through nearly 40 years of industrial practice, it has been found that the stress state developed by the application of normal stress alone can successfully approximate that developed in steady state flow.

8.2.4.3 Calculate the mass of the weights to be placed on the weight carrier from:

$$m_{wt} = \frac{A \times \sigma_1}{g} - m_c - m_R - m_L - m_B \quad (1)$$

where:

m_c = mass of the weight carrier.

(1) Since the shear strength after time consolidation is not very sensitive to the force σ_1 , it is sufficient to select m_{wt} to satisfy Eq 1 to within $\pm 5\%$.

8.2.4.4 After the chosen time, t , has elapsed, remove the weights from the weight carrier, raise the flexible cover, raise the weight carrier, and transfer the shear cell to the shear tester.

8.2.5 *Shear of Specimen After Time Consolidation:*

8.2.5.1 Select a weight m_{ws} . Perform shear in the same manner as for instantaneous flow. For time tests, select no more than three shear normal stress levels for each preshear stress.

NOTE 15—Due to the scatter obtained in time shear tests, it is recommended that they be performed at least twice.

8.3 *Procedure for Wall Friction:*

8.3.1 Stack weights on the hanger corresponding to the wall friction normal stress σ_{w6} . Include the weight of the hanger in the calculation of σ_w . Place the hanger on the lid. Select the weights in such a way that by removing a weight (or weights) the normal stress is reduced stepwise from $\sigma_{w(i+1)}$ to σ_{wi} .

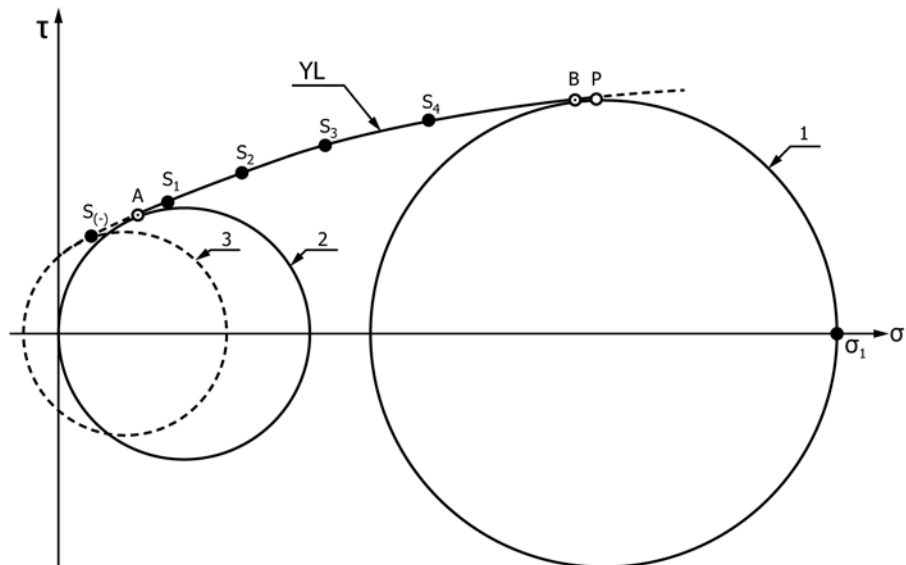

FIG. 11 Yield Locus Showing Valid Shear Points

8.3.2 Check to make sure that the ring is not touching the wall coupon. If it is, twist and manually lift the ring slightly to prevent it from dragging on the coupon. Then, switch on the motor driving the force-measuring stem.

NOTE 16—As the shear starts, the shear stress will begin to rise. It will approach a steady state either directly or may pass through a maximum.

8.3.3 Determine by visual inspection of the recorder chart when the shear stress τ_{w6} has reached a constant value. Then remove weight(s) until the normal stress is reduced to σ_{w5} . Continue to advance the stem during removal of the weights. When the shear stress has again reached a constant value, record the shear stress, τ_{w5} , and remove more weights to reduce the normal stress to σ_{w4} . When the shear stress has again become constant, record the stress τ_{w4} . Continue this procedure over the range of selected normal stresses.

8.3.4 If the stem has reached the limit of its travel before the whole range of required normal stresses has been tested (say at normal stress σ_{wi}), retract the stem, remove the normal load on the cover, carefully push back the ring to the locating screws, increase the normal stress to $\sigma_{w(i+1)}$ and continue testing, ignoring the first (repeated) reading of $\tau_{w(i+1)}$.

8.3.5 On completion of the tests, weigh the specimen to determine m_B .

8.3.6 Repeat wall friction tests two to three times with new specimens of the particulate solid.

NOTE 17—Sometimes there will be a rapid oscillation of the indicated shear force because of slip-stick behavior. The shear stress maxima recorded during shear will be used to evaluate the wall friction angle ϕ .

NOTE 18—In many cases there is no distinct difference between static and kinematic friction. However, the shear force may pass through a maximum when starting a wall friction test, that is, there is a peak shear stress at τ_{w6} .

8.3.7 If static friction is suspected, the static angle of wall friction can be determined as follows: A test is performed as previously described, but when the shear force has passed through the maximum the stem is retracted. After the shear force has fallen to zero, the weight on the hanger is reduced and the motor is started again. The shear force will again pass through a maximum, and the procedure of retracting the stem and reducing the weight is repeated. The peak values of τ_w are used to evaluate the static angle of wall friction.

8.4 Wall Friction Time Tests:

8.4.1 Static wall friction tests with time consolidation are also known as adhesion tests.

8.4.2 Cut three coupons of the same wall material to fit under the covers of the consolidating bench and wash and dry them thoroughly.

8.4.3 Perform a wall friction test using wall friction normal stresses, σ_{w6} to σ_{w1} , to obtain a defined compaction of the particulate solid particles. Retract the stem and push back the shear ring against the locating screws. Increase the load to σ_{w6} and perform a shear test until the shear stress attains a constant value. Without stopping, remove shear weights to obtain the stress σ_{w5} . When the shear stress again reaches a constant value, stop and retract the stem.

NOTE 19—This step can be considered as wall friction ‘preshear’ which gives the ‘initial’ shear stress τ_{wp5} .

8.4.4 Remove the weights and hanger and very carefully place the wall coupon with material specimen, shear ring, and shear lid onto the consolidating bench under the cover.

NOTE 20—At this time, the material specimen will have little or no adhesion to the wall plate and may move slightly. This, however, does not negate the test.

8.4.5 Using the weight carrier or hanger with appropriate weights, apply the normal stress, σ_{w5} . If a weight carrier is used, calculate the appropriate weights required using Eq 1.

8.4.6 After the chosen time, t , has elapsed, transfer the wall coupon with material specimen, shear ring, and shear lid to the shear tester. Take care not to bump the specimen during this transfer as any break in the adhesive bond will nullify the test. Using the weight hanger and weights, load the shear lid to give a normal stress σ_{w5} and perform shear in the normal way. The shear stress will pass through a maximum, the ‘time’ wall friction shear stress, and is given the symbol τ_{wt5} .

8.4.7 The pair of stresses (σ_{w5} , τ_{wt5}) define Point S_{w5} . Using the second wall coupon, obtain another point (σ_{w3} , τ_{wt3}) by preshearing the specimen under normal stresses of σ_{w4} and σ_{w3} and time consolidate it at σ_{w3} as previously described. Obtain a third point (σ_{w1} , τ_{wt1}) using the normal stresses, σ_{w2} and σ_{w1} , for preshear and σ_{w1} for time consolidation. Further points (σ_{w4} , τ_{wt4}) and (σ_{w2} , τ_{wt2}) can be measured using the same procedure.

9. Calculation or Interpretation of Results

9.1 Data Processing for Instantaneous Shear Tests:

9.1.1 Prorating:

NOTE 21—Ideally, all values of the preshear shear stress, τ_p , for a given preshear normal stress would be identical. This would occur if the specimen was perfectly homogeneous, and specimen preparation completely repeatable. However, because of unavoidable experimental variation there is a scatter of τ_p values which affects the value of the shear stress, τ_s .

9.1.1.1 To minimize the scatter, all measured shear stresses, τ_s , may be corrected to take into account scatter in the preshear shear stresses, τ_p . This empirical procedure is called prorating, and prorated values of τ'_s of the measured values τ_s are evaluated using the following equation:

$$\tau'_s = \tau_s \frac{\bar{\tau}_p}{\tau_p} \quad (2)$$

where $\bar{\tau}_p$ = average of the preshear, shear stresses, τ_p , of the corresponding preshear normal stress level (yield locus). Prorating assumes that variations in consolidation produce variations in shear stress, τ_s , that are proportional to the corresponding variation in preshear shear stress, τ_p .

9.1.2 Determination of Valid Shear Points:

9.1.2.1 For each consolidation condition (σ_p), plot prorated and averaged shear points $S_i(\sigma_s, \tau'_s)$ of repeated measurements and the averaged preshear point $P_i(\sigma_p)$ on a σ, τ -diagram (Fig. 12).

9.1.2.2 To determine whether a yield point is valid, the following procedure is adopted.

9.1.2.3 Fit by means of a least squares fit a straight line called the yield locus, YL , to the three highest points S_2 , S_3 , and S_4 (Fig. 12).

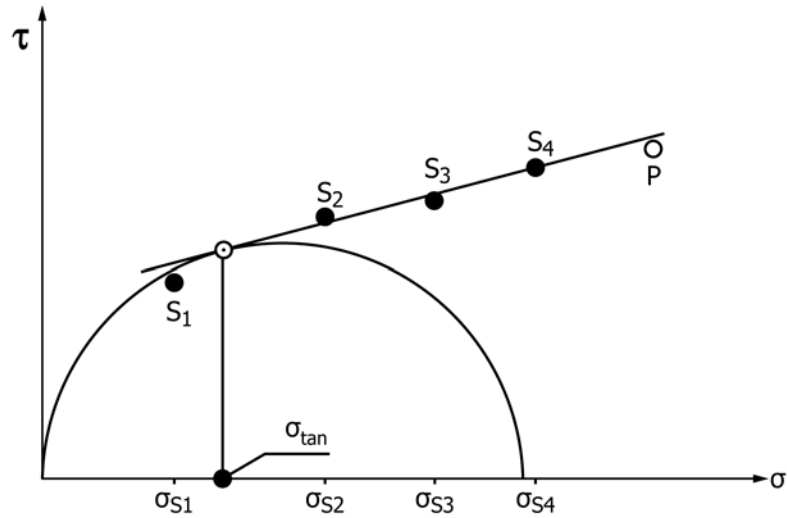

FIG. 12 Yield Locus and Data Points

9.1.2.4 If the straight line passes through or above Point *P*, it can be used for further calculation. If, however, the straight line passes below Point *P* but the deviation in shear stress (between the steady state value and the extrapolated value based on the yield locus *YL*) is less than 5 % (Fig. 13), it should be replotted to pass through Point *P* and refitted to the points *S*₂, *S*₃, and *S*₄ (Fig. 14), and this new straight line should be used for further calculations. If the deviation is more than 5 %, either additional shear points should be run or the test should be redone at a different level of consolidation.

(1) From an inspection of the σ, τ -diagram, it can be seen that the shear points on a yield locus are not equally spaced from zero normal stress to preshear normal stress, but begin at a certain minimum value of normal stress and end some distance before the preshear normal stress is reached. Considering the situation in more detail, Fig. 11 shows one yield locus with a preshear point *P* and four valid shear points, *S*₁–*S*₄. One Mohr circle, 1, (the steady state Mohr circle) is drawn through the preshear Point *P* and tangentially to the extrapolated yield locus (the point of tangency is shown on Fig. 11 as *B* and

defines the end point of the yield locus).⁴ A second Mohr circle, 2, (the unconfined strength Mohr circle) is drawn, passing through the origin and tangential to the extrapolated yield locus (this point of tangency is denoted by *A* in Fig. 11). Yield points to be considered must lie between the points of tangency *A* and *B*. Points to the right of *B* may be valid or invalid; thus, for the purpose of this test method, they are ignored.

(2) Points to the left of Point *A* are ignored because they represent a state where tensile stresses can occur in the shear cell. This can be seen by considering the yield point on Fig. 11 marked by *S*₍₋₎, below Point *A*. If a Mohr circle 3 is drawn through this point, which is tangential to the extrapolated yield locus, part of that circle will lie to the left of the origin indicating negative normal stresses, that is, tensile stresses.

⁴ This method of constructing the steady state Mohr circle is specified by the EFCE and Jenike. Alternative methods of construction have been proposed. See for example, Peschl.

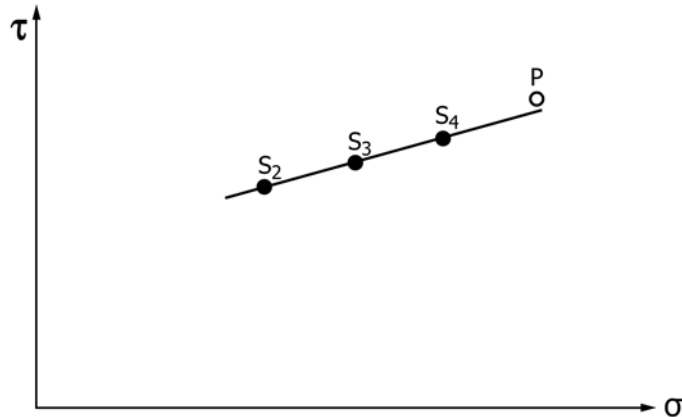

FIG. 13 End Point Above Fitted Line

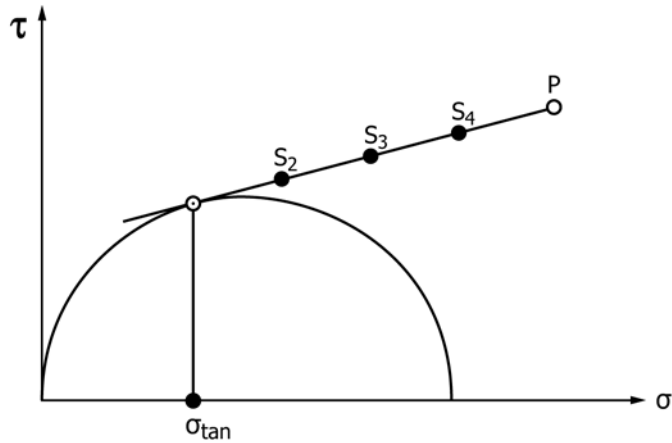

FIG. 14 End Points on Fitted Line

9.1.3 Evaluate results separately for every chosen value of the preshear normal stress, although all points should be shown on one σ, τ -diagram.

9.1.4 Plot the preshear point, P , and all valid shear points for one given preshear normal stress level in σ, τ -coordinates. Draw a smooth line through the valid points and extrapolate it to the preshear normal stress. If this line passes above or through Point P , use it for further calculations. If it passes below Point P , plot a new line passing through Point P and fit it to all the valid yield points.

9.1.5 Draw a Mohr circle through the origin, tangential to this smooth line, the instantaneous yield locus (YL in Fig. 15).

NOTE 22—The higher point of intersection of this Mohr circle with the σ -axis is the unconfined yield strength, f_c . Calculate to three significant digits.

9.1.6 Draw a second Mohr circle through Point P , tangential to the smooth line in such a way that the point of tangency is to the left of the preshear Point P .

NOTE 23—The upper point of intersection of this Mohr circle with the normal stress axis is the major consolidation stress, σ_1 . Calculate to three

significant digits. In this way, the pair of values, f_c and σ_1 , associated with this particular yield locus are produced, these values all being associated with the major consolidation stress σ_1 .

NOTE 24—The yield locus is normally found to show a small curvature, convex upwards. With many particulate solids, a straight line is a sufficient approximation. If the yield locus is approximated as a straight line for all particulate solids, then subsequent calculations are much simpler, but, in some cases, somewhat conservative results may be obtained, that is, a higher f_c value will be determined than when using a fitted curve.

9.1.7 Determine to nearest 1° the angle of internal friction of the particulate solid, ϕ_i , at the major consolidation stress, σ_1 , by measuring the angle between a yield locus and the σ -axis.

9.1.7.1 Since this angle varies with σ when using a smooth line yield locus, its value should be read from the linearized yield locus (LYL), which is the tangent to the two Mohr circles characterizing the major principal stresses σ_1 and f_c (Fig. 15).

9.1.8 Draw a straight line through the origin, tangential to the major principal stress Mohr circle. This line, which is the effective yield locus (EYL), forms an angle δ with the axis, called the effective angle of friction. It should be determined to

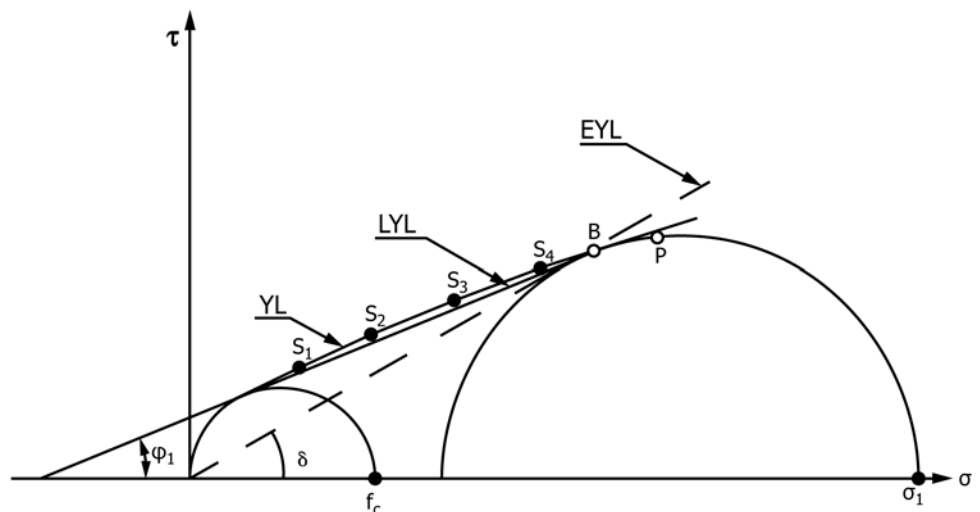

FIG. 15 Mohr Circles, Angles of Friction and Yield Loci

nearest 1°. For a given preshear normal stress and value of σ_1 , determine a mean bulk density, ρ_b to four significant digits.

9.1.9 The preceding calculation produces values of f_c , ϕ_i , δ , and ρ_b for a given σ_1 . By making measurements at several preshear normal stresses, the dependencies of f_c , ϕ_i , δ , and ρ_b on σ_1 can be determined as shown in Fig. 16).

9.1.10 Fit a smooth curve through the pairs of points (σ_1, f_c) . See Fig. 16e). The σ_1 and f_c coordinates should be to the same scale. The dependency of f_c on σ_1 is called the Flow Function (FF) for instantaneous flow.

NOTE 25—The Flow Function usually has a slight curvature convex upwards.

9.1.11 Fit a smooth curve through the points (σ_1, δ) as shown in Fig. 16d. Also, plot in a similar way ϕ_i and ϕ_t as shown in Fig. 16a.

NOTE 26—For cohesive materials δ will decrease with increasing σ_1 .

9.2 Evaluation of Time Shear Test Data:

9.2.1 Prorate the time shear stress values using the following equation:

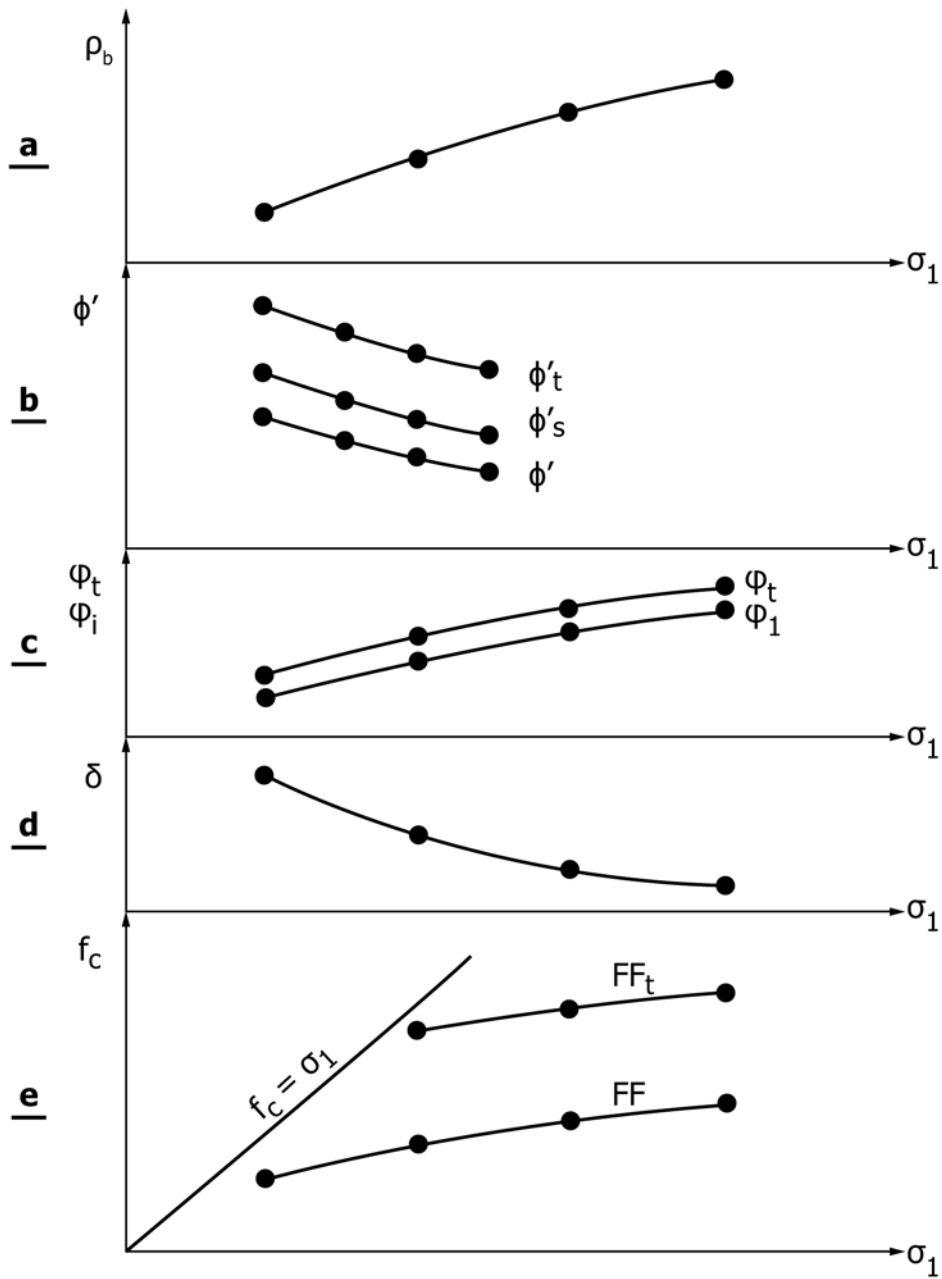

FIG. 16 Powder Properties as a Function of σ_1

$$\tau'_{st} = \tau_{st} - \left[\tau'_s \left(\frac{\tau_{pt}}{\bar{\tau}_p} - 1 \right) \right] \quad (3)$$

where:

- τ'_{st} = prorated time shear value of τ_{st}
- τ'_s = prorated instantaneous shear value (Eq 2) for the same shear normal stress,
- τ_{pt} = preshear shear stress for the time test, and
- $\bar{\tau}_p$ = average of the instantaneous preshear shear stress values.

9.2.2 *Validity of Time Shear Points*—Plot the time shear points in σ, τ -coordinates (Fig. 17) and draw a straight line called the time yield locus, *TYL*, through the highest shear point and parallel to the instantaneous yield locus (for that particular preshear normal stress level). Draw a Mohr circle through the origin and tangential to this straight line.

NOTE 27—Those time shear points which lie to the right of this point of tangency A_t of the Mohr circle to the straight line time yield locus are considered valid. The normal stress applied at shear for the highest time yield point S_{3t} is generally less than the normal stress applied at the end point, B , of the instantaneous yield locus.

9.2.3 Carry out evaluations separately for each preshear normal stress level. Plot the valid time shear points for each preshear normal stress level in σ, τ -coordinates (Fig. 18). Fit a smooth line through the points. This smooth line is called the time yield locus.

9.2.4 Draw a Mohr circle through the origin and tangential to the time yield locus.

9.2.4.1 The highest point of intersection of this Mohr circle with the σ -axis is the time unconfined yield strength, f_{ct} . Calculate to three significant digits. This value, together with the major consolidation stress for instantaneous flow, σ_1 , for each selected preshear normal stress gives the values σ_1, f_{ct} that are used in plotting the time flow function, FF_t .

9.2.4.2 The angle between the time yield locus and the σ -axis is the time angle of internal friction, ϕ_t for that particular σ_1 (Fig. 18). It should be determined to nearest 1°.

9.2.5 Plot the time flow function, FF_t , by fitting a smooth curve or a straight line to the pairs (σ_1, f_{ct}) from each yield locus.

9.3 *Evaluation of Wall Friction Test Data:*

9.3.1 Plot the points σ_{wi}, τ_{wi} on σ, τ -coordinates and draw a smooth line through the points (Fig. 19).

9.3.1.1 This is the wall yield locus (*WYL*) of the particulate solid on the specific wall material. The plot of the *WYL* will be a straight line or a curve convex upwards.

9.3.2 If the wall yield locus is a straight line passing through the origin, then $\phi' = \text{constant}$. Otherwise, superimpose a steady state flow Mohr circle associated with a yield locus and a major consolidation stress, σ_1 , on the *WYL*. Determine the upper point of intersection of the *WYL* with the steady state flow Mohr circle and draw a straight line through the origin and this point of intersection. The angle that this straight line subtends with the σ -axis is the kinematic angle of wall friction ϕ' at this particular major consolidation stress σ_1 . It should be determined to nearest 1°.

9.3.3 By repeating the procedure with consolidating Mohr circles associated with higher preshear normal stresses, obtain the corresponding values (σ_1, ϕ') for each preshear normal stress.

9.3.4 Obtain the static angle of wall friction ϕ'_s by using the σ_{wi}, τ_{wi} values of the peaks. The steady state values give the kinematic angle of wall friction ϕ' . It should be determined to nearest 1°.

9.3.5 Plot ϕ' and ϕ'_s as a function of σ_1 , as shown in Fig. 16b.

9.4 *Evaluation of wall friction time test data:*

9.4.1 Evaluate wall friction time tests in a similar way to kinematic wall friction tests. Plot the points S_{wt} on σ, τ -coordinates and fit them by a smooth line called the time wall yield locus (*TWYL*). The analysis gives a time angle of wall friction ϕ'_t for each of the σ_1 values of the superimposed steady state Mohr circles. It should be determined to nearest 1°.

9.4.2 Plot ϕ'_t as a function of σ_1 as shown in Fig. 16b.

10. **Report: Test Data Sheet(s)/Form(s)**

10.1 The methodology used to specify how data are recorded on the test data sheet(s)/form(s), as given below, is covered in 1.4.

10.2 Report as a minimum the following general information (data):

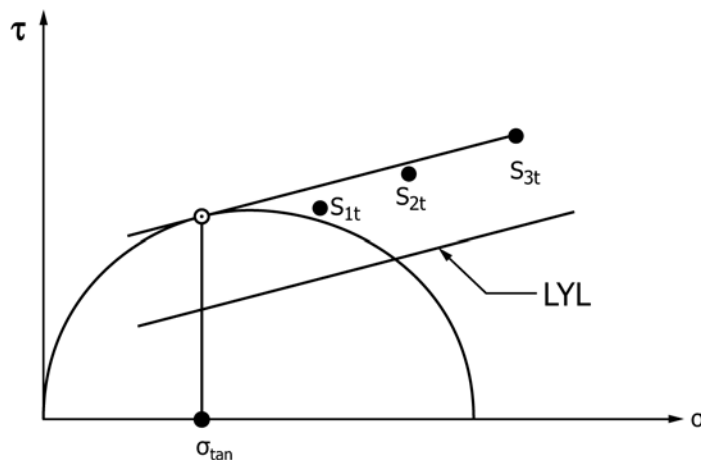

FIG. 17 Validity of Points on the Time Yield Locus

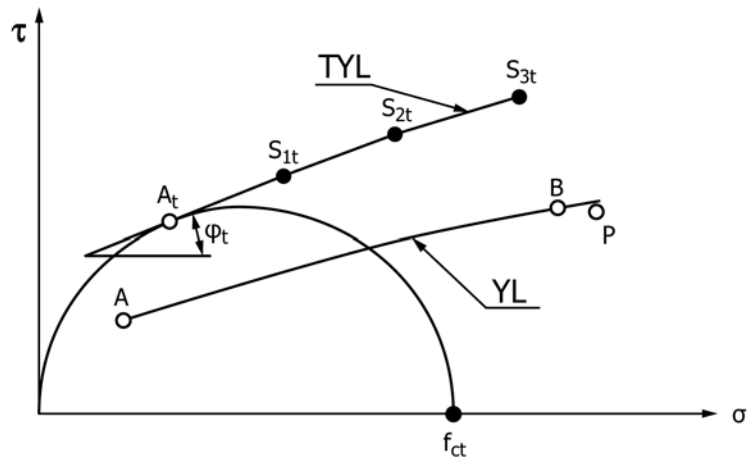

FIG. 18 Time Yield Locus

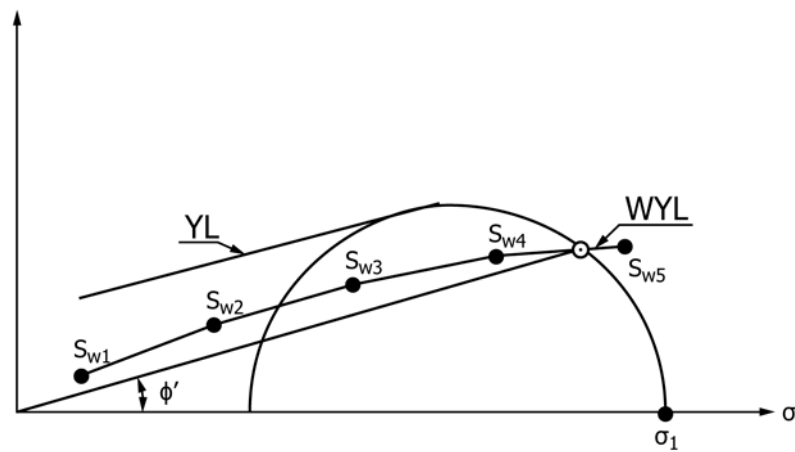

FIG. 19 Wall Yield Locus

10.2.1 Requesting agency or client and/or identifying number for job or project.

10.2.2 Technician name or initials, and

10.2.3 Date test was run.

10.3 Report the following test specimen information (data):

10.3.1 Generic name of powder tested.

10.3.2 Chemical name of sample, if known.

10.3.3 Specimen moisture (water) content, if determined, to the nearest 0.1%. Indicate method used to determine moisture if not Test Method [D2216](#).

10.3.4 Temperature of specimen, to the nearest 1°C.

10.4 Provide in plot form the following properties as a function of σ_1 . Report all stresses to three significant digits and all angles to nearest 1°:

10.4.1 Unconfined yield strength, f_c , that is, flow function, FF

10.4.2 Time unconfined yield strength, f_{ct} , that is, time flow function FF_t

10.4.3 Effective angle of friction, δ

10.4.4 Bulk density, ρ_b to four significant digits

10.4.5 Angle of internal friction, ϕ_i , for instantaneous flow

10.5 When required by the application, provide in plot form the following additional properties as a function of σ_1 :

10.5.1 Angle of internal friction, ϕ_t , after time consolidation

10.5.2 Angle of kinematic wall friction, ϕ'

10.5.3 Angle of static wall friction, ϕ'_s

10.5.4 Angle of time wall friction, ϕ'_t

11. Precision and Bias

11.1 *Precision*—Test data on precision is not presented due to the nature of the powder and other bulk solids tested by this standard. It is either not feasible or too costly at this time to have ten or more laboratories participate in a round-robin testing program. In addition, it is either not feasible or too costly to produce multiple specimens that have uniform physical properties. Any variation observed in the data is just as likely to be due to specimen variation as to operator or laboratory testing variation.

11.1.1 Subcommittee D18.24 is seeking any data from the users of this standard that might be used to make a limited statement on precision.

11.2 *Bias*—There is no accepted reference value for this test method; therefore, bias cannot be determined.

12. Keywords

12.1 bulk solid; cohesive strength; effective angle of friction; effective yield locus; flow function; internal friction angle; Jenike shear cell; kinematic wall friction angle; powder; translational shear tester; unconfined yield strength; wall friction

ANNEXES

(Mandatory Information)

A1. LIST OF SYMBOLS

A	cross-sectional area of cell, m^2	ϕ'_s	static angle of wall friction, $^\circ$
F_v	vertical force, N	ϕ'_t	time angle of wall friction, $^\circ$
F_s	shear force, N	ϕ_i	angle of internal friction, $^\circ$
f_c	unconfined yield strength, N/m^2	ϕ_t	time angle of internal friction, $^\circ$
f_{ct}	time unconfined yield strength, N/m^2	σ	normal stress, N/m^2
g	acceleration due to gravity ($g = 9.81 \text{ m/s}^2$), m/s^2	σ_p	preshear normal stress, N/m^2
m_B	mass of particulate solid in shear ring, kg	σ_s	shear normal stress or normal stress at shear, N/m^2
m_C	mass of weight carrier on time consolidation bench, kg	σ_{tw}	normal stress during twisting, N/m^2
m_H	mass of hanger, kg	σ_w	wall normal stress, N/m^2
m_L	mass of shear lid, kg	ρ_b	bulk density, kg/m^3
m_M	total mass of particulate solid in shear cell, kg	τ	shear stress, N/m^2
m_R	mass of shear ring, kg	τ_p	shear stress at preshear, N/m^2
m_W	mass of weights, kg	$\bar{\tau}_p$	average shear stress at preshear, N/m^2
m_{WP}	mass of weights during preshear, kg	τ_{pt}	shear stress at preshear measured during time consolidation test, N/m^2
m_{Ws}	mass of weights during shear, kg	τ_s	shear stress at failure (shear point), N/m^2
m_{Wt}	mass of weights during time consolidation, kg	τ_{st}	shear stress at failure (shear point) measured during time consolidation test, N/m^2
m_{Wtw}	mass of weights during twisting, kg	τ'_s	prorated shear stress at failure, N/m^2
p	averaged preshear point	τ'_{st}	prorated time shear stress value at failure N/m^2
s_i	prorated and averaged shear point	τ_w	wall shear stress, N/m^2
T	thickness of shear ring, mm	τ_{wp}	initial shear stress in wall friction time test, N/m^2
t	consolidation time, h	τ_{wt}	time wall shear stress, N/m^2
δ	effective angle of friction, $^\circ$		
ϕ'	kinematic angle of wall friction, $^\circ$		

A2. SELECTION OF SAMPLE, SHEAR CELL, AND TEST WEIGHTS

A2.1 Sample Selection:

A2.1.1 For meaningful results, select a representative sample of the particulate solid with respect to moisture content, particle size distribution, and temperature. For the tests approximately 10 L of the material should be available, and fresh material should be used for each individual test specimen. If such a quantity is not available, use a smaller shear cell. If as a last resort shear tests have to be repeated on the same specimen, then before each test, the material should be well loosened.

A2.1.2 The flowability of a particulate solid is usually significantly dependent on its moisture content which at equilibrium depends on the ambient humidity. In view of the significant influence of moisture, the amount anticipated during actual storage and flow should be closely reproduced in the test specimen, for example, by equilibrating it to this humidity. To prevent moisture evaporation or adsorption, it is advisable to

keep the test material in an airtight container, replacing the cover of the container between tests. To prevent inhomogeneities in water content, stir the material in the container regularly and, during the test, handle the specimen and the shear cells rapidly. Upon completion of time tests, recheck the moisture in the solid from the shear cells. Ideally, measurements should be made in an air-conditioned room with controlled humidity.

A2.1.3 The effect of particle size distribution is not as perplexing as it might appear. During the flow of a mass of mixed particle sizes, the large particles move bodily while the solid shears primarily across the fines. The coarse particles contribute little to the cohesion of the mass; therefore, the flowability of the mass depends on the properties of the fines. The Jenike shear cell is suitable for testing particulate solids with particle sizes of up to 5 % of the shear cell diameter. Coarser particles should be removed by hand. When removing the larger particles, it is necessary, in so far as possible, to

retain the structure of the solid and the moisture content of the fines. If there is danger that by sieving the structure of the solid will be altered, spread the material gently on a tray and remove the larger particles by hand. Do not screen fibrous solids, whose strength is due to the interlocking of the fibers. Such solids are on the borderline of applicability of this test method. Take great care to make sure that the particles do not segregate between sample withdrawal and testing (for example, during transport coarse particles can segregate towards the surface of a material in a container and, if this surface material is taken for shear testing, it will have a lower shear strength). If tests are repeated on the same specimen, take care not to lose fines, for example, by ventilation.

A2.1.4 The effect of temperature on the flowability of solids may be significant. Tests of such solids require either a shear tester and a consolidating bench which permit the adjustment and control of temperature, or a temperature-controlled room.

A2.1.5 The coupon of wall material should be flat, 120-mm square or larger and representative of the material on which the particulate solid will slide. Take care in that some types of wall materials have directional properties (for example, rolled steels). In such cases, orient the coupon of wall material in the same direction as in the actual equipment (hopper).

A2.1.6 The effect of vibration on the shear strength of particulate solids is not treated in this test method. However, since vibrations influence the shear strength of particulate solids to a considerable extent, take care that during measurements the shear cell is completely free of any vibration either from the force-measuring stem driving mechanism, or from the test room.

A2.2 Shear Cell Selection:

A2.2.1 When measuring the shear strength of particulate solids having bulk densities in the range from 300 to approximately 2400 kg/m³, use a standard size shear cell. For particulate solids with bulk densities below 300 kg/m³, or when performing shear tests at very low normal stress levels, a light metal shear cell is recommended.

A2.2.2 At higher preshear normal stress levels and with particulate solids having bulk densities above 2400 kg/m³, a shear cell of smaller diameter may be used.

A2.3 Equivalence Between Weights and Stresses:

A2.3.1 The results of shear tests are expressed in terms of stresses, that is, by the shear stress and the normal stress in the shear plane (plane between shear ring and base). However, cells are loaded by weights and therefore it is necessary to equate these weights to the corresponding stresses. This equivalence is given by the following equations:

$$\sigma = \frac{F_v}{A} = \frac{(m_B + m_R + m_L + m_H + m_W) g}{A} \quad (\text{A2.1})$$

where:

- σ = normal stress, Pa,
- m_B = mass of particulate solid in the shear ring, kg,
- m_R = mass of the ring, kg,
- m_L = mass of the shear lid, kg,

- m_H = mass of the weight hanger, kg,
- m_W = mass of the weights, kg,
- g = acceleration due to gravity (9.81 m/s²), and
- F_v = vertical force, N,
- A = cross-sectional area of the cell, m².

$$\tau = \frac{F_s}{A} \quad (\text{A2.2})$$

where:

- τ = shear stress, Pa and
- F_s = shear force, N.

If weights are stacked directly on the lid when running shear tests without a hanger, the term m_H is omitted from Eq A2.1. Read the shear force, F_s , from the calibrated recorder.

A2.3.2 In this test method, the loading of shear cells by weights is expressed in the form of the normal stress in the shear plane. The operator of the shear cell, therefore, must derive from Eq A2.1 the corresponding weight of mass m_W , which he places on the hanger. Selection of the masses of weights corresponding to preshear normal stresses may be rounded up to 1 kg if above 4 kg and to 0.5 kg if below 4 kg. Selection of the masses of weights corresponding to shear normal stresses may be rounded up to kilograms if above 6 kg, to 0.5 kg if between 2 and 6 kg, and to 0.1 kg if below 2 kg. This rounding up is used only for the selection of weights. From the total of the masses in question, calculate the normal stress to an accuracy of 10 Pa.

A2.3.3 In order to attain the required degree of accuracy, measure all weighed components to a precision of 1 g. Although weights are normally well within the required tolerance, it is advisable to check them on purchase. A recently calibrated balance is suitable for this. When plotting dependencies of τ on σ , it is necessary to know the mass of powder above the plane of shear, which in Eq A2.1 is approximated by the amount of material in the ring, m_B . To measure this, determine the total mass of particulate solid in the shear cell, m_M , by weighing the base, shear ring, shear lid, and material in the cell to the required 1-g precision after the shear test and from the known volumes of the ring and base, calculate the corresponding mass of material above the shear plane, m_B . This assumes that the contents of the cell are homogeneous with respect to density. For cohesive materials, the amount of material above the shear plane may be determined directly by weighing the shear ring and the powder in it after shear. As the actual shear plane does not usually coincide with the plane between the ring and base, direct measurement will probably give results that are different from those calculated from m_M and the volumes of the parts of the cell. For the same reason, directly determined values of m_B are likely to vary more from test to test.

A2.3.4 These discrepancies are likely to be insignificant for all tests, except for those at the lowest normal loads. For more free-flowing materials which are likely to fall out of the ring as it is lifted, the direct method cannot be used and the volumetric method is necessary. Particulate solids bulk densities, ρ_b , should be calculated from m_M rather than direct weight of material in the ring as the differences in volume of solids from

test to test due to differences in the position of the plane of shear will be much more significant with respect to the mass of particulate solids alone compared with the sum of the masses in Eq A2.1. As the base has an irregular inside shape, its volume is best determined by weighing it empty and then again when filled with water exactly to the top. Determine the volume of the ring from its dimensions.

A2.3.5 If the shear tester is used with several bases, rings, and shear lids, it is advisable to mark the parts so that the weights of those used in a particular test may be readily identified.

A3. OPTIMIZATION PROCEDURE

A3.1 Trial tests which are performed with the aim of obtaining a critically consolidated specimen are called optimization. Optimization has to be repeated for each preshear normal stress level.

A3.2 Inspect the shear force-time record, which is equivalent to a shear stress-shear strain record, and depending upon the degree of compaction of the particulate solid produced by the applied weight of mass m_{wp} , three general types of shear force – shear strain curves may be obtained (shown by full lines in Fig. A3.1).

A3.3 If for the material under test the degree of compaction is insufficient, the shear force will increase continually during shear (Fig. A3.1, Curve 3). Such a specimen is said to be under-consolidated, and the bulk density in the shear zone increases during shear. If the degree of compaction is excessive, the shear force rises initially, passes through a maximum and then decreases (Curve 1). Such a specimen is said to be over-consolidated, and the bulk density in the shear zone is thought to decrease after passing through a maximum.

A3.4 There is, however, a degree of compaction when the shear force rises initially, but having reached a certain value remains constant during the remainder of shear (Curve 2). Such

a specimen is said to be critically consolidated, and that part of the test when the shear force is constant is called steady state flow. In such a specimen, the bulk density and shear stress in the shear zone remain constant during shear.

A3.5 It has been shown that for a given particulate solid at a given normal stress acting in the shear zone, the shear stress and the bulk density during steady state flow have unique values.

A3.6 Thus, it can be seen that for a given m_{wp} , the plot of the shear force versus strain strongly depends on the original bulk density of the particulate solid in the cell which in turn is a result of the degree of compaction of the material during preparation of the specimen for shear testing.

A3.7 The shear test, therefore, consists of two parts. The first of these is the preparation of a critically consolidated specimen and the attainment of steady state flow in the shear cell with a definite bulk density in the shear zone. This bulk density is defined by the values of the normal and shear stresses for steady state flow. In the second part of the test, an actual shear stress measurement is performed in which, for a selected value of the normal force, $m_{ws} < m_{wp}$, the necessary shear force for the material to yield is determined.

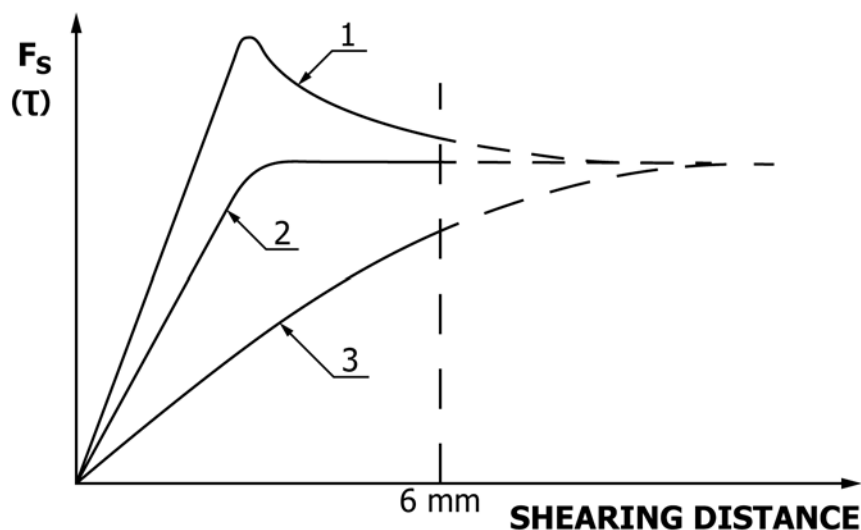

FIG. A3.1 Stress-Strain Curves for Over, Critically and Under Consolidated Specimens

A3.8 To simplify the situation, it is possible to imagine that if the shear cell was capable of shear through an infinite distance (for example, in an annular shear cell) then steady state flow could be attained simply by allowing the specimen to shear through a long enough distance. Under-consolidated specimens would follow the full and then the dashed line marked 3 in Fig. A3.1. Over-consolidated specimens would follow the full and then the dashed Curve 1 in Fig. A3.1. In both cases, the shear force would eventually attain the level corresponding to a critically consolidated specimen, as in Curve 2. (In reality, this is not necessarily the case since prolonged shear can by the attrition or orientation of particles in the shear zone lead to the formation of a single shear plane whose properties may be different from those of a shear zone.)

A3.9 The Jenike shear cell, however, is limited to a shear distance of approximately 6 mm, represented by the dashed vertical line in Fig. A3.1. Therefore steady state flow must be attained within a shear distance of up to 4 to 5 mm leaving the remaining distance for the actual shear test. For the specimen to attain steady state flow in such a short shear distance, the specimen must be close to critical consolidation prior to shear. The technique for obtaining steady state flow during a short shear distance, called consolidation, was developed by Jenike and consists of twisting and preshear.

A3.10 If the specimen is under-consolidated (Fig. A3.1, Curve 3), then prepare additional specimens in which the number of twists is increased stepwise to a maximum of 50. For each number of twists selected, perform a shear test and inspect the stress-strain record until critical consolidation is found to have occurred. If after 50 twists the specimen is still under-consolidated, increase the consolidating normal stress applied during twisting by approximately $0.5 \sigma_p$ increments. Shear specimens again after being twisted by up to 50 times. When a consolidating normal stress is found which produces an over-consolidated specimen (Curve 1), make a finer adjustment of the consolidating normal stress σ_{tw} and of the number of twists to obtain a critically consolidated specimen. Alternative techniques are sometimes required in order to obtain this desired result.

A3.11 If the specimen after the first test is over-consolidated, decrease the number of twists during twisting stepwise to a minimum of about 5 and, if the material is still found to be over-consolidated, reduce the consolidating normal stress. Again make a final adjustment of σ_{tw} and number of twists to obtain a critically consolidated specimen.

A3.12 The output from the stress-strain recorder need not be a smooth curve but may contain various irregularities due to the formation of shear planes. Some experience is necessary in interpreting the stress-strain records to identify the conditions for critical consolidation. It is helpful to obtain a distinctly under-consolidated specimen, a distinctly over-consolidated specimen, and then an intermediate condition for critical consolidation, tending toward the under-consolidated, never the over-consolidated state. With some materials it is very difficult to obtain over-consolidated specimens; therefore, it is necessary to judge the stress-strain curves from only under-consolidated and critically consolidated specimens.

A3.13 The steady state shear stress should be attained after a shear distance not greater than three fourths of the total shear distance permitted by the amount of overlap between the rings in order to allow for further shear during the shear test itself.

A3.14 If the particulate solid specimen is prone to attrition, σ_{tw} should not be increased beyond $2\sigma_p$. If under these conditions the specimen is still under-consolidated, perform twisting with $\sigma_{tw} = 2\sigma_p$ and start preshear with a stack of weights on the hanger corresponding to a total normal force of $2\sigma_p$. As the shear force rises, remove weights one at a time, keeping pace with the rise of the shear force until only weights corresponding to σ_p remain on the hanger. At no time during preshear, however, should the recorded shear stress exceed that finally determined for steady state flow.

A3.15 When testing some coarse materials, the front of the shear ring may rise somewhat (over 1 mm) during preshear or shear. In such cases, it is possible to manually press the front of the ring gently down to maintain alignment of the shear ring and base.

REFERENCES

- (1) *Standard Shear Testing Technique for Particulate Solids using the Jenike Shear Cell*, a report of the EFCE Working Party on the Mechanics of Particulate Solids. Copyright is held by The Institution of Chemical Engineers and the European Federation of Chemical Engineering, Rugby, England, 1989.
- (2) Jenike, A. W., *Storage and Flow of Solids*, Bul. 123, Utah Engineering Experiment Station, 1964 (Rev. 1980).
- (3) Peschl, I.A.S.Z., "Measurement and Evaluation of Mechanical Properties of Powders," *Powder Handling and Processing*, Vol 1, No. 2, June 1989, pp. 135–142.

SUMMARY OF CHANGES

In accordance with Committee D18 policy, this section identifies the location of changes to this standard since the 2014 edition that may impact the use of this standard. (February 1, 2016)

- (1) Changed title from “Shear Cell” to “Shear Tester.”
- (2) Reference to D4753 added.
- (3) Separated former 6.3 into three sections.
- (4) Moved former 6.8 and Note 10 to 7.1.
- (5) In 6.9, maximum capacity of laboratory balance expressed in kg instead of N.
- (6) Some or all of former Notes 4-6, 11-19, 22, 23, 25, 28, 34, 35, and 38-40 made mandatory.
- (7) A portion of former 7.3.4 combined with former 7.3.3 (now 7.4.3).
- (8) Former 8.1.2.3 moved to new 7.5.
- (9) Former 8.3.1 through 8.3.3 moved to new 7.6.
- (10) Former 8.1.1 combined with former 8.1.2 (now Section 8.1.1).
- (11) Former 8.1.5, 8.1.6, 8.2.5.2, 8.2.6 and 8.2.6.1 moved to Section 9.
- (12) Significant digits added to Notes 22 and 23 as well as to 9.1.5, 9.1.6, 9.2.2.1, 9.2.2.2, 9.3.2, 9.3.4 and 9.4.1.

ASTM International takes no position respecting the validity of any patent rights asserted in connection with any item mentioned in this standard. Users of this standard are expressly advised that determination of the validity of any such patent rights, and the risk of infringement of such rights, are entirely their own responsibility.

This standard is subject to revision at any time by the responsible technical committee and must be reviewed every five years and if not revised, either reapproved or withdrawn. Your comments are invited either for revision of this standard or for additional standards and should be addressed to ASTM International Headquarters. Your comments will receive careful consideration at a meeting of the responsible technical committee, which you may attend. If you feel that your comments have not received a fair hearing you should make your views known to the ASTM Committee on Standards, at the address shown below.

This standard is copyrighted by ASTM International, 100 Barr Harbor Drive, PO Box C700, West Conshohocken, PA 19428-2959, United States. Individual reprints (single or multiple copies) of this standard may be obtained by contacting ASTM at the above address or at 610-832-9585 (phone), 610-832-9555 (fax), or service@astm.org (e-mail); or through the ASTM website (www.astm.org). Permission rights to photocopy the standard may also be secured from the Copyright Clearance Center, 222 Rosewood Drive, Danvers, MA 01923, Tel: (978) 646-2600; <http://www.copyright.com/>