



# Standard Practice for Using the Electronic Piezocone Penetrometer Tests for Environmental Site Characterization<sup>1</sup>

This standard is issued under the fixed designation D6067; the number immediately following the designation indicates the year of original adoption or, in the case of revision, the year of last revision. A number in parentheses indicates the year of last reappraisal. A superscript epsilon ( $\epsilon$ ) indicates an editorial change since the last revision or reappraisal.

## 1. Scope\*

1.1 The electronic cone penetrometer test often is used to determine subsurface stratigraphy for geotechnical and environmental site characterization purposes (1).<sup>2</sup> The geotechnical application of the electronic cone penetrometer test is discussed in detail in Test Method D5778, however, the use of the electronic cone penetrometer test in environmental site characterization applications involves further considerations that are not discussed. For environmental site characterization, it is highly recommended to use the Piezocone (PCPT or CPTu) option in Test Method D5778 so information on hydraulic conductivity and aquifer hydrostatic pressures can be evaluated.

1.2 The purpose of this practice is to discuss aspects of the electronic cone penetrometer test that need to be considered when performing tests for environmental site characterization purposes.

1.3 The electronic cone penetrometer test for environmental site characterization projects often requires steam cleaning the push rods and grouting the hole. There are numerous ways of cleaning and grouting depending on the scope of the project, local regulations, and corporate preferences. It is beyond the scope of this practice to discuss all of these methods in detail. A detailed explanation of grouting procedures is discussed in Guide D6001.

1.4 The electronic cone penetrometer may be combined with other direct push sampling and testing methods. Estimated soil types can be confirmed by soil sampling (Guide D6282). Cone penetrometer tests are often used to locate aquifers for installation of wells (Practice D5092, Guide D6274). Cone penetrometers can be equipped with additional sensors for groundwater quality evaluations (Practice D6187). Location of other sensors must conform to requirements of Test Method D5778.

<sup>1</sup> This practice is under the jurisdiction of ASTM Committee D18 on Soil and Rock and is the direct responsibility of Subcommittee D18.21 on Groundwater and Vadose Zone Investigations.

Current edition approved May 1, 2010. Published June 2010. Originally approved in 1996. Last previous edition approved in 2003 as D6067–96(2003) DOI: 10.1520/D6067-10.

<sup>2</sup> The boldface numbers in parentheses refer to the list of references at the end of this guide.

1.5 This practice is applicable only at sites where chemical (organic and inorganic) wastes are a concern and is not intended for use at radioactive or mixed (chemical and radioactive) waste sites.

1.6 The values stated in SI units are to be regarded as standard. No other units of measurement are included in this standard.

1.7 *This standard does not purport to address all of the safety concerns, if any, associated with its use. It is the responsibility of the user of this standard to establish appropriate safety and health practices and determine the applicability of regulatory limitations prior to use.*

1.8 *Standard Practice—This practice offers a set of instructions for performing one or more specific operations. This document cannot replace education or experience and should be used in conjunction with professional judgment. Not all aspects of this practice may be applicable in all circumstances. This ASTM standard is not intended to represent or replace the standard of care by which the adequacy of a given professional service must be judged, nor should this document be applied without consideration of a project's many unique aspects. The word "Standard" in the title means only that the document has been approved through the ASTM consensus process.*

## 2. Referenced Documents

### 2.1 ASTM Standards:<sup>3</sup>

- C150 Specification for Portland Cement
- D653 Terminology Relating to Soil, Rock, and Contained Fluids
- D3740 Practice for Minimum Requirements for Agencies Engaged in Testing and/or Inspection of Soil and Rock as Used in Engineering Design and Construction
- D5088 Practice for Decontamination of Field Equipment Used at Waste Sites
- D5092 Practice for Design and Installation of Groundwater Monitoring Wells
- D5778 Test Method for Electronic Friction Cone and Piezocone Penetration Testing of Soils

<sup>3</sup> For referenced ASTM standards, visit the ASTM website, www.astm.org, or contact ASTM Customer Service at service@astm.org. For *Annual Book of ASTM Standards* volume information, refer to the standard's Document Summary page on the ASTM website.

\*A Summary of Changes section appears at the end of this standard

- D6001** Guide for Direct-Push Groundwater Sampling for Environmental Site Characterization
- D6187** Practice for Cone Penetrometer Technology Characterization of Petroleum Contaminated Sites with Nitrogen Laser-Induced Fluorescence
- D6274** Guide for Conducting Borehole Geophysical Logging - Gamma
- D6282** Guide for Direct Push Soil Sampling for Environmental Site Characterizations

3.2.10 *equilibrium pore water pressure,  $u_o$ ,  $n$* —at rest water pressure at depth of interest. Same as hydrostatic head. **D653**

3.2.11 *excess pore water pressure,  $u-u_o$ ,  $n$* —the difference between pore pressure measured as the penetraoin occurs,  $u$ , and estimated equilibrium pore water pressure,  $u_o$ . Excess pore pressure can be either positive or negative.

3.2.12 *friction ratio,  $R_f$ ,  $n$* — the ratio of friction sleeve resistance,  $f$ , to cone resistance,  $q_c$ , measured with the middle of the friction sleeve at the same depth as the cone point. It is usually expressed as a percentage.

3.2.13 *friction reducer,  $n$* —a narrow local protuberance on the outside of the push rod surface, placed at a certain distance above the penetrometer tip, which is provided to reduce the total side friction on the push rods and allow for greater penetration depths for a given push capacity.

3.2.14 *friction sleeve resistance,  $f_s$ ,  $n$* —the friction component of penetration resistance developed on a friction sleeve, equal to the shear force applied to the friction sleeve divided by its surface area.

3.2.15 *friction sleeve,  $n$* —an isolated cylindrical sleeve section on a penetrometer tip upon which the friction component of penetration resistance develops.

3.2.16 *local friction,  $n$* —same as friction sleeve resistance.

3.2.17 *penetrometer,  $n$* —an apparatus consisting of a series of cylindrical push rods with a terminal body (end section) called the penetrometer tip and measuring devices for determination of the components of penetration resistance.

3.2.18 *penetrometer tip,  $n$* —the terminal body (end section) of the penetrometer which contains the active elements that sense the components of penetration resistance.

3.2.19 *piezocone,  $n$* —same as electronic piezocone penetrometer.

3.2.20 *piezocone pore pressure,  $u$ ,  $n$* —fluid pressure measured using the piezocone penetration test.

3.2.21 *push rods,  $n$* —the thick walled tubes or rods used to advance the penetrometer tip.

3.2.22 *sleeve friction or resistance,  $n$* —same as friction sleeve resistance,  $f$ .

3.2.23 *stratigraphy,  $n$* —a classification of soil behavior type that categorizes soils of lateral continuity (2).

3.3 *Acronyms:*

3.3.1 *CPT*—Cone Penetration Test.

3.3.2 *PCPT or CPTu*—Piezocone Penetration Test. **D5778**

3.4 *Abbreviations:*

3.4.1  $t_{50}$ —time for dissipation of 50 percent of the excess excess pore water pressure during dissipation tests.

## 4. Significance and Use

4.1 Environmental site characterization projects almost always require information regarding subsurface soil stratigraphy and hydraulic parameters related to groundwater flow rate and direction. Soil stratigraphy often is determined by various drilling procedures and interpreting the data collected on borehole logs. The electronic piezocone penetrometer test is

## 3. Terminology

### 3.1 Definitions:

3.1.1 For definitions of terms related to this standard, refer to Terminology **D653**.

3.1.2 *hydraulic conductivity (in field aquifer tests),  $n$* —the volume of water at the existing kinematic viscosity that will move in a unit time under a hydraulic gradient through a unit area measured at right angles to the direction of flow.

### 3.2 Definitions of Terms Specific to This Standard:

3.2.1 *baseline,  $n$* —a set of zero load readings, expressed in terms of apparent resistance, that are used as reference values during performance of testing and calibration.

3.2.2 *bentonite,  $n$* —the common name for drilling fluid additives and well construction products consisting mostly of naturally occurring sodium montmorillonite. Some bentonite products have chemical additives that may affect water quality analyses.

3.2.3 *cone,  $n$* —the conical point of a cone penetrometer on which the end bearing component of penetration resistance is developed.

3.2.4 *cone resistance,  $q_c$ ,  $n$* — the end bearing component of penetration resistance.

3.2.5 *cone sounding,  $n$* —a series of penetration readings performed at one location over the entire depth when using a cone penetrometer.

3.2.6 *dissipation test,  $n$* —test where the dissipation of excess pore water pressure generated during push is monitored to evaluate depth specific hydraulic conductivity and final pressure head of the soil when penetration is stopped.

3.2.6.1 *Discussion*—Either complete or 50 % dissipation is monitored. Complete dissipation can be used to determine equilibrium pore water pressure and thus hydrostatic head at a point in the aquifer. The time required for dissipation depends on the soil type.

3.2.7 *electronic cone penetrometer,  $n$* —a friction cone penetrometer that uses force transducers, such as strain gage load cells, built into a nontelelescoping penetrometer tip for measuring within the penetrometer tip, the components of penetration resistance.

3.2.8 *electronic piezocone penetrometer,  $n$* — an electronic cone penetrometer equipped with a low-volume fluid chamber, porous element, and pressure transducer for determination of pore pressure at the porous element soil interface.

3.2.9 *end bearing resistance,  $n$* —same as cone resistance or tip resistance,  $q_c$ .

another means of determining soil stratigraphy that may be faster, less expensive, and provide greater resolution of the soil units than conventional drilling and sampling methods. For environmental site characterization applications, the electronic piezocone also has the additional advantage of not generating contaminated cuttings that may present other disposal problems (3, 4, 2, 5, 6, 7, 8, 9). Investigators may obtain soil samples from adjacent borings for correlation purposes, but prior information or experience in the same area may preclude the need for borings (1). Most cone penetrometer rigs are equipped with direct push soil samplers (Guide D6282) that can be used to confirm soil types.

4.2 The electronic piezocone penetration test is an in situ investigation method involving:

4.2.1 Pushing an electronically instrumented probe into the ground (see Fig. 1 for a diagram of a typical cone penetrometer). The position of the pore pressure element may vary but is typically located in the  $u_2$  position (Test Method D5778).

4.2.2 Recording force resistances, such as tip resistance, local friction, and pore water pressure.

4.2.3 Data interpretation.

4.2.3.1 The most common use of the interpreted data is stratigraphy based on soil behavior types. Several charts are available. A typical CPT soil behavior type classification chart is shown in Figs. 2 and 3 (10). The first step in determining the extent and motion of contaminants is to determine the subsur-

face stratigraphy. Since the contaminants will migrate with groundwater flowing through the more permeable strata, it is impossible to characterize an environmental site without valid stratigraphy. Cone penetrometer data has been used as a stratigraphic tool for many years. The pore pressure channel of the cone can be used to determine the depth to the water table or to locate perched water zones.

4.2.3.2 Hydraulic conductivity can be estimated based on soil behavior type (Figs. 4 and 5). These estimates span two to three orders of magnitude. Alternately, pore pressure data (4.5) can be used for refined estimates of hydraulic conductivity.

4.3 When attempting to retrieve a soil gas or water sample, it is advantageous to know where the bearing zones (permeable zones) are located. Although soil gas and water can be retrieved from on-bearing zones such as clays, the length of time required usually makes it impractical. Soil gas and water samples can be retrieved much faster from permeable zones, such as sands. The cone penetrometer tip and friction data generally can identify and locate the bearing zones and nonbearing zones less than a foot thick very accurately.

4.4 The electronic cone penetrometer test is used in a variety of soil types. Lightweight equipment with reaction weights of less than 10 tons generally are limited to soils with relatively small grain sizes. Typical depths obtained are 20 to 40 m, but depths to over 70 m with heavier equipment

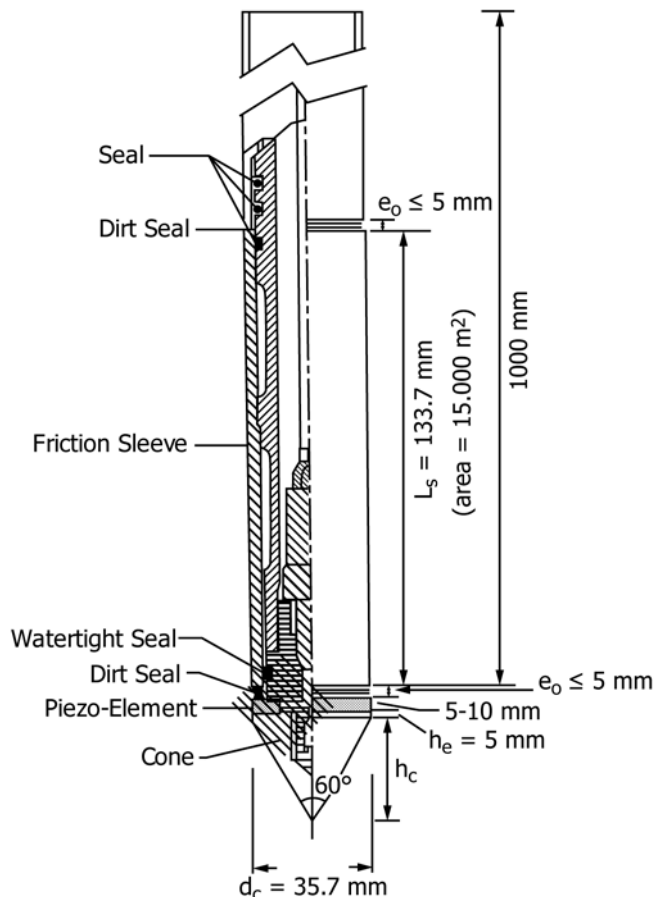
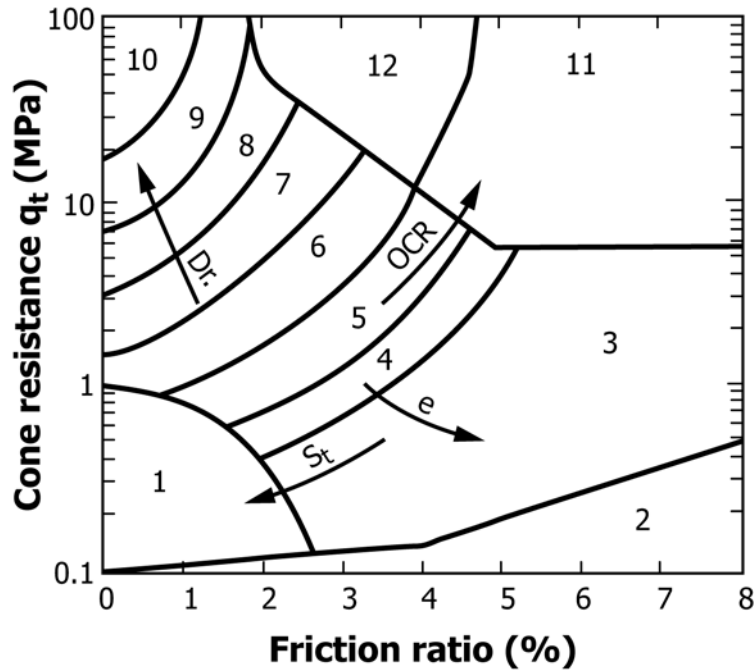

FIG. 1 Electronic Cone Penetrometer (Test Method D5778-07)



Zone	Soil Behavior Type
1	Sensitive fine grained
2	Organic material
3	Clay
4	Silty Clay to clay
5	Clayey silt to silty clay
6	Sandy silt to clayey silt
7	Silty sand to sandy silt
8	Sand to silty sand
9	Sand
10	Gravelly sand to sand
11	Very stiff fine grained*
12	Sand to clayey sand*

\* Overconsolidated or cemented

FIG. 2 Simplified Soil Classification Chart for Standard Electric Friction Cone (Robertson and Campanella 1986) (10)

weighing 20 tons or more are not uncommon. Since penetration is a direct result of vertical forces and does not include rotation or drilling, it cannot be utilized in rock or heavily cemented soils. Depth capabilities are a function of many factors including:

- 4.4.1 The force resistance on the tip,
- 4.4.2 The friction along the push rods,
- 4.4.3 The force and reaction weight available,
- 4.4.4 Rod support provided by the soil, and
- 4.4.5 Large grained materials causing nonvertical deflection or unacceptable tool wear.
- 4.4.6 Depth is always site dependent. Local experience is desirable.

4.5 Pore Pressure Data:

4.5.1 Excess pore water pressure data often are used in environmental site characterization projects to identify thin soil

layers that will either be aquifers or aquitards. The pore pressure channel often can detect these thin layers even if they are less than 20 mm thick.

4.5.2 Excess pore water pressure data taken during push are used to provide an indication of relative hydraulic conductivity. Excess pore water pressure is generated during an electronic cone penetrometer test. Generally, high excess pore water pressure indicates the presence of aquitards (clays), and low excess pore water pressure indicates the presence of aquifers (sands). This is not always the case, however. For example, some silty sands and over-consolidated soils generate negative pore pressures if monitored above the shoulder of the cone tip. See Fig. 1. The balance of the data, therefore, also must be evaluated. There have been methods proposed to estimate hydraulic conductivity from excess pore water pressure measurements (11, 12, 13).

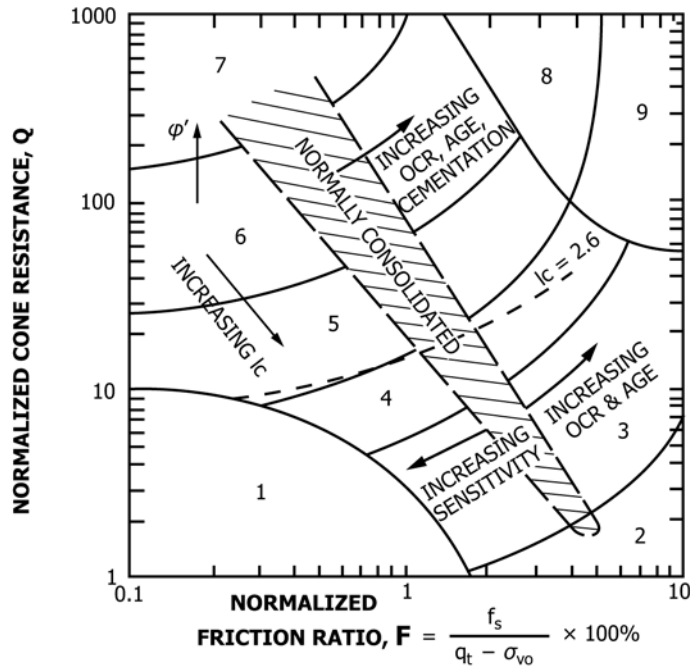

Zone	Soil Behavior Type	$I_c$
1	Sensitive, fine grained	N/A
2	Organic soils - peats	>3.6
3	Clays - silty clay to clay	2.95-3.6
4	Silt mixtures - clayey silt to silty clay	2.60-2.95
5	Sand mixtures - silty sand to sandy silt	2.05-2.6
6	Sands - clean sand to silty sand	1.31-2.05
7	Gravelly sand to dense sand	<1.31
8	Very stiff sand to clayey sand*	N/A
9	Very stiff, fine grained*	N/A

\*Heavily overconsolidated or cemented

FIG. 3 Normalized Soil Classification Chart for Standard Electric Friction Cone (Robertson 1990) (10)

Zone	Soil Behavior Type (SBT)	Range of Permeability k (m/s)
1	Sensitive fine grained	$3 \times 10^{-9}$ to $3 \times 10^{-8}$
2	Organic soils	$1 \times 10^{-8}$ to $1 \times 10^{-6}$
3	Clay	$1 \times 10^{-10}$ to $1 \times 10^{-9}$
4	Silty clay to clay	$1 \times 10^{-9}$ to $1 \times 10^{-8}$
5	Clayey silt to silty clay	$1 \times 10^{-8}$ to $1 \times 10^{-7}$
6	Sandy silt to clayey silt	$1 \times 10^{-7}$ to $1 \times 10^{-6}$
7	Silty sand to sandy silt	$1 \times 10^{-5}$ to $1 \times 10^{-6}$
8	Sand to silty sand	$1 \times 10^{-5}$ to $1 \times 10^{-4}$
9	Sand	$1 \times 10^{-4}$ to $1 \times 10^{-3}$
10	Gravelly sand to dense sand	$1 \times 10^{-3}$ to 1
11	Very stiff fine-grained soil	$1 \times 10^{-8}$ to $1 \times 10^{-6}$
12	Very stiff sand to clayey sand	$3 \times 10^{-7}$ to $3 \times 10^{-4}$

FIG. 4 Estimation of Hydraulic Conductivity from Non-Normalized CPT SBT Chart (10)

Zone	Soil Behavior Type (SBT <sub>N</sub> )	Range of Permeability k (m/s)
1	Sensitive fine grained	$3 \times 10^{-9}$ to $3 \times 10^{-8}$
2	Organic soils	$1 \times 10^{-8}$ to $1 \times 10^{-6}$
3	Clay	$1 \times 10^{-10}$ to $1 \times 10^{-9}$
4	Silt mixtures	$3 \times 10^{-9}$ to $1 \times 10^{-7}$
5	Sand mixtures	$1 \times 10^{-7}$ to $1 \times 10^{-5}$
6	Sands	$1 \times 10^{-5}$ to $1 \times 10^{-3}$
7	Gravelly sands to dense sands	$1 \times 10^{-3}$ to 1
8	Very stiff sand to clayey sand	$1 \times 10^{-8}$ to $1 \times 10^{-6}$
9	Very stiff fine-grained soil	$1 \times 10^{-8}$ to $1 \times 10^{-6}$

FIG. 5 Estimation of Hydraulic Conductivity from Normalized CPT VSBT Chart (10)

4.5.3 Dissipation Tests:



4.5.3.1 In general, since the groundwater flows primarily through sands and not clays, modeling the flow through the sands is most critical. The pore pressure data also can be monitored with the sounding halted. This is called a pore pressure dissipation test. A rapidly dissipating pore pressure indicates the presence of an aquifer while a very slow dissipation indicates the presence of an aquitard. Fig. 6 shows one proposed relationship between dissipation time, soil type, and hydraulic conductivity (14).

4.5.3.2 A pore pressure decay in a sand is almost instantaneous. The permeability (hydraulic conductivity), therefore, is very difficult to measure in a sand with a cone penetrometer. As a result, until recently the cone penetrometer was not used very often for measuring the permeability of sands in environmental applications. Newly developed hardware and software now allow for high resolution data collection even in rapidly dissipating sand formations (15).

4.5.3.3 A thorough study of groundwater flow also includes determining where the water cannot flow. Cone penetrometer pore pressure dissipation tests can be used very effectively to study the permeability of aquitards (16).

4.5.3.4 The pore pressure data also can be used to estimate the depth to the water table or identify perched water zones. This is accomplished by allowing the excess pore water pressure to equilibrate and then subtract the appropriate head pressure. Due to high excess pore pressures being generated, typical pore pressure transducers are configured to measure pressures up to 3.5 MPa. Since transducer accuracy is a function of maximum range, this provides a relative depth to water level accuracy of about ±150 mm. Better accuracy can be achieved if the operator allows sufficient time for the transducer to dissipate the heat generated while penetrating dry soil above the water table. Lower pressure transducers are

sometimes used just for the purpose of determining the depth to the water table more accurately. For example, a 175-KPa transducer would provide accuracy that is better than 10 mm. Incorporation of a temperature transducer and appropriate calibration allows for high precision and rapid data collection. Caution must be used, however, to prevent these transducers from being damaged due to a quick rise in excess pressure. Some newer systems allow for large burst pressure protection without hysteresis, which enables users to collect data in highly stratified environments without as much concern for transducer damage.

4.5.3.5 When coupled with appropriate models, three dimensional gradient can be derived from final pressure values collected from multiple CPT locations. Once gradient distributions have been derived, and hydraulic conductivity and effective porosity distributions have been generated, seepage velocity distributions can be derived and visualized. This type of information is critical to environmental investigations and remediation design. If contaminant concentration distributions are known, the same software can be used to derive three dimensional distributions of contaminant mass flux.

4.6 For a complete description of a typical geotechnical electronic cone penetrometer test, see Test Method D5778.

4.7 This practice tests the soil in situ. Soil samples are not obtained. The interpretation of the results from this practice provides estimates of the types of soil penetrated. Investigators may obtain soil samples from adjacent borings for correlation purposes, but prior information or experience in the same area may preclude the need for borings.

4.8 Certain subsurface conditions may prevent cone penetration. Penetration is not possible in hard rock and usually not possible in softer rocks, such as claystones and shales.

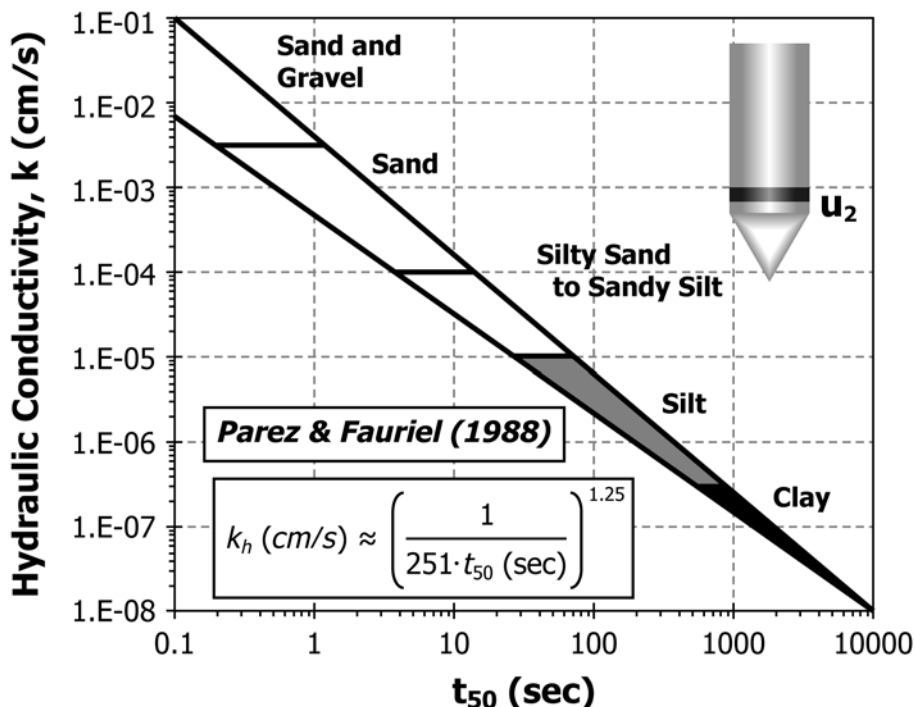

FIG. 6 Proposed Relationship between T50 Dissipation Time, Soil Type, and Hydraulic Conductivity (15)

Coarse particles, such as gravels, cobbles, and boulders may be difficult to penetrate or cause damage to the cone or push rods. Cemented soil zones may be difficult to penetrate depending on the strength and thickness of the layers. If layers are present which prevent direct push from the surface, rotary or percussion drilling methods can be employed to advance a boring through impeding layers to reach testing zones.

NOTE 1—The quality of the result produced by this standard is dependent on the competence of the personnel performing it, and the suitability of the equipment and facilities used. Agencies that meet the criteria of Practice D3740 are generally considered capable of competent and objective testing/sampling/inspection/etc. Users of this standard are cautioned that compliance with Practice D3740 does not in itself assure reliable results. Reliable results depend on many factors; Practice D3740 provides a means of evaluating some of those factors.

Practice D3740 was developed for agencies engaged in the testing or inspection of soils and rock or both. As such, it is not totally applicable to agencies performing this practice. However, users of this practice should recognize that the framework of Practice D3740 is appropriate for evaluating the quality of an agency performing this practice. Currently there is no known qualifying national authority that inspects agencies that perform this practice.

5. Apparatus

5.1 Most apparatus required is discussed in Test Method D5778. When using the electronic cone penetrometer test for environmental site characterization purposes, however, other items often are necessary.

5.2 Safety Equipment—Environmental site characterization often involves exposure to potentially hazardous substances. Detection equipment to determine oxygen content and the presence of combustible or toxic materials may be required. Numerous air monitors are available to detect harmful situations, such as the lack of oxygen, excess carbon monoxide or carbon dioxide, the presence of methane, or other combustible gasses. Other devices, such as flame-ionization or photoionization detectors and LELs can be used to monitor vapors from the rods or the hole, or both, to forewarn the operators of potential contamination. Operator protective equipment, such as breathing apparatus and bodily protection, also may be required.

5.3 Laboratory Equipment—The electronic cone penetrometer often is used in conjunction with sampling devices and field laboratory equipment (see Guide D6001). Since many cone penetrometer systems are deployed from enclosed, air conditioned, and heated trucks, these vehicles can also be used as a mobile laboratory. This unique capability provides rapid on-site analysis. First, the cone penetrometer data eliminates most guess work in determining where to retrieve samples. Second, the on-site laboratory analysis can provide important information, such as where to retrieve subsequent samples and avoids many unnecessary samples. On-site laboratory instruments range from simple portable devices, such as photoionization devices, to sophisticated gas chromatographs and mass spectrometers (GC-MS). This approach often is called Expedited Site Characterization.

5.4 Steam Cleaning Equipment—When the push rods are withdrawn from the ground, they may be contaminated by toxic, combustible, or corrosive compounds. If this is the case, the push rods will need to be steam cleaned. Many dedicated

purpose systems have built in chambers that automatically steam clean the rods while they are being withdrawn from the ground and before they enter the vehicle. A typical diagram of an automatic decontamination assembly is shown in Fig. 7.

5.4.1 Steam Cleaner/High-Pressure Washer— Portable or trailer-mounted for cleaning the rods after grouting, with appropriate hoses for connection to the steam cleaning unit.

5.4.2 Personal Protective Equipments, such as boots, gloves, glasses, and so forth.

5.4.3 Water Trough Cleaning Tub, for cleaning grout rods and containing grey water.

5.4.4 Shotgun Bristle Brush, for cleaning inside of cone or grout rods.

5.5 Grouting Equipment—When multiple groundwater aquifers have been penetrated, grouting the hole closed after the test is completed may also be required to prevent cross contamination of one aquifer by another. A detailed explanation of grouting procedures is discussed in guide D6001. The equipment required includes, but may not be limited to the following:

5.5.1 Expendable Grout Tips for the Grout Rods—These tips should be conical in shape and have an outside diameter larger than the grout rods. Tip size will be varied to enlarge the hole and to reduce friction on the push rods.

5.5.2 Suitable Small-Diameter Grout Rods— These rods may be steel or PVC. The type and size depends on the capability of being pushed back down the same CPT hole.

5.5.3 Grout Line Connector Assembly™ —This assembly is screwed into the top of the grout rods. A pressure fitting may be required if gravity placement is unacceptable and pressure is required to force grout down the rods. Since this fitting must be attached and unattached many times it may be preferable to have a quick-connect coupling.

5.5.4 Foot Clamps/Retraction Jack, for holding and manually extracting rods.

5.5.5 Hoisting Plug, for holding rods by overhead rope or cable.

5.5.6 Grout Mixing Equipment—Grouting quantities for cone holes are small with only 20 to 60 L of grout required for filling. In many cases grout mixing in small tubs with mechanical agitation devices are acceptable.

5.5.7 Cement, see Specification C150. Either Type I or Type II cements are acceptable. Cement should be supplied in sacks.

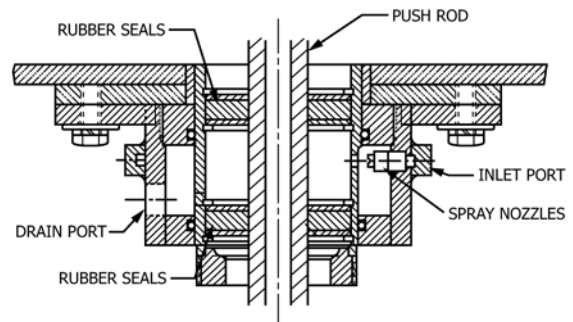

FIGURE #3  
DECON ASSEMBLY

FIG. 7 Decontamination Assembly

5.5.8 *Bentonite*, powdered high-yield sodium montmorillonite or prehydrated bentonite. The bentonite should not contain any particular additives.

5.5.9 *Potable Water*, or mixing grout. As long as an acceptable supply of drinking water is found, the chemical analysis may not be required.

5.5.10 *Mixing Tubs*, 20 to 60-L plastic mixing tubs with rope handles (for mixing grout if an automatic mixer is not used).

5.5.11 *Drill-Powered Mixing Paddles*, for mixing grout in tubs by hand. Using a hand-powered drill with a stem equipped with blades for mixing.

5.5.12 *Platform Scale*, for weighing mixture proportions.

5.5.13 *Personal Protective Equipment*, eye protection from splashes of grout.

5.5.14 *Flexible Nylon*, reinforced 15 or 10-mm outside diameter tubing, for feeding grout by gravity into the grout rods.

5.5.15 *Depth-Graduated Tape*, for measuring grout levels in rods.

## 6. Reagents and Materials<sup>4</sup>

6.1 In addition to the substances described in Test Method **D5778**, the following may be necessary:

6.2 *Water*—A significant amount of water may be required for decontamination purposes. This water may become contaminated and need to be evaluated and properly disposed.

6.3 *Cleaning Agents*—Cleaning of the push rods and cone penetrometer requires a detergent, such as alconox, or solvent, such as hexane. Some contaminants cannot be removed by standard methods as described in Practice **D5088**. The operating personnel must be aware of the anticipated contaminants and fully understand the required cleaning procedures. Recognize that some cleaning agents, particularly solvents such as hexane, also are hazardous substances. Regional protocol and regulations influence the selection of cleaning agents.

6.4 *Grout*—Various types of bentonite and cement often are required to seal the hole at the end of the sounding. Regional regulations and protocol dictate exactly what grout materials will be required. Usually, the bentonite used is powdered and the cement is portland, though sometimes ultrafine cement is used if it is to be pumped through a small tube. See **5.5**.

## 7. Hazards

7.1 Environmental site characterization can present numerous hazards to equipment and personnel. It is the responsibility of everyone involved with the environmental site characterization project to understand fully all potential hazards.

7.2 **Warning**—Hazards to personnel include, but are not limited to, fire; toxicity; heat exhaustion; local vegetation, such as poison ivy; local animals, such as snakes, or simply

accidents due to the cumbersome aspects of safety equipment. A complete understanding of the OSHA 40-h safety course and the Health and Safety Plan<sup>5</sup> is required.

7.3 **Warning**—Hazards to equipment include, but are not limited to, fire or chemical attack. Seals for the cone penetrometer must be compatible with the local contaminants.

## 8. Procedure

8.1 The first step of any environmental site characterization project is to understand fully safety issues, such as the Health and Safety Plan, and having the area cleared and marked for utilities. A proper Health and Safety Plan addresses the aspects that apply specifically to the cone penetration operation and not just to drilling.

8.2 Upon arrival at the site, review the definition of the project to determine if any safety issues have been overlooked. If any unanticipated hazardous situation exists, notify the proper authorities immediately. An exclusion zone around the vehicle must be established to prevent unauthorized entry in the area. Appropriate flagmen, warning signs, cones, and street markings is required if the work is near a street or parking lot.

8.3 Regulations and safety specifications often are generic in nature and are intended to cover a wide variety of environmental site characterization projects. It is possible that one or more of these procedures could be counterproductive or even present an alternative hazard. If this is the case, notify the appropriate authorities immediately.

8.4 Calibrate the cone penetrometer in accordance with Test Method **D5778**. All probe sensors (e.g., temperature and pressure) and reference sensors (e.g., barometric pressure) must be calibrated prior to probe advancement.

8.5 The porous element and pressure transfer chamber must be carefully filled with non-compressible fluid such as glycerin or silicon fluid in a manner that prohibits formation of air bubbles.

8.6 All cleaning, grouting, and safety equipment must be in good working order and fully prepared before starting each cone penetration test.

8.7 Perform the electronic piezocone penetrometer test in accordance with Test Method **D5778**. Note any variances to the test due to environmental conditions.

8.8 Monitor the pore pressure dissipation. If monitoring is done, the cone should be saturated fully in accordance with the manufacturer's recommendations. The data acquisition system should begin timing automatically the dissipation the instant the rod motion is stopped.

8.9 During the extraction process, monitor for volatile organic compounds with a PID or FID at the top of rods and in the breathing zone and note readings in the scientific notebook. Take wipe samples as required in the health and safety plans.

<sup>4</sup> *Reagent Chemicals, American Chemical Society Specifications*, American Chemical Society, Washington, DC. For suggestions on the testing of reagents not listed by the American Chemical Society, see *Analar Standards for Laboratory Chemicals*, BDH Ltd., Poole, Dorset, U.K., and the *United States Pharmacopeia and National Formulary*, U.S. Pharmacopeial Convention, Inc. (USPC), Rockville, MD.

<sup>5</sup> Follow NIOSH/OSHA Pocket Guide to Chemical Hazards, NIOSH/OSHA Occupational Health Guidelines for Chemical Hazards, and NIOSH/OSHA Occupational Safety and Health Guidance Manual for Hazardous Waste Site Activities available from U.S. Dept. of Health and Human Services, Centers for Disease Control, U.S. Government Printing Office.



If any chemical constituent exceeds safe limits, as determined by the health and safety plan, respirators or other appropriate action will be required in the breathing zone. Use double gloves at all times while handling rods.

8.10 During disassembly of rods, if there is any free water within the rod column, these rods must be treated carefully. Check free water with an FID or PID. If this water registers PID readings or appears discolored, remove the end rods in the string from the cone truck or cleaned appropriately.

8.11 Clean the equipment according to predetermined appropriate methods. Inspect the equipment regularly for chemical attack and seal deterioration. First, externally clean and dry the cone. This will help prevent contaminants from intruding during disassembly for a more thorough cleaning. If only limited contamination exists and no cleaning is required, store the penetrometer in plastic or foil, and do not handle the penetrometer without protective gloves. The O-rings in the cone may need to be inspected or changed, or both, after every sounding. Change the O-rings if they appear to be swollen, stuck to the metal surfaces, or spongy. If they appear to be deteriorating rapidly, use a more impervious compound. O-ring deterioration may cause erroneous friction data. A different compound, however, also may alter the data.

8.12 Normally, the dirt seals in the joints around the sleeve jacket contain only a minor amount of soil (less than 1 g) such that there is usually no concern for cross contamination between sounding sites. In cases where cleaning is required, the soil and fluids that the cone was exposed to may be considered contaminated; therefore, take the following measures to clean and decontaminate the cone.

8.13 Contamination will only be present on the cone body and the seals around the piezo element and friction sleeve. Place a protective cap over the electrical connector. Wash the cone with a brush and warm water and nonphosphate detergent, such as Alconox, and rinse with deionized water. Repeat as necessary to remove any visible soil from o-ring and quad-ring areas. O-rings, quad-rings, and piezo elements can be discarded during disassembly.

8.14 After pore pressure soundings, the pore pressure element may require special attention. Whereas, in geotechnical cone penetrometer tests, the elements can be used more than one time. In environmental tests, the pore pressure elements may need to be replaced and discarded after each test if the material has been chemically degraded.

8.15 Grout the holes closed according to the appropriate predetermined method. A complete discussion of grouting holes resulting from direct push tools is discussed in Guide **D6001**. Reentry grouting is the most common method of grouting (6). The grout rod could be a PVC pipe, a plastic tube, or another steel pipe, depending on how well the hole stays open. A grout rod will follow the path of least resistance and often can be pushed to the complete depth of the original CPT hole. This method is simple and usually very effective.

8.16 There are several methods of grouting during rod retraction without reentry. The following discussion is intended to discuss advantages and disadvantages of each method. Not all methods are discussed, but most methods include the following principles.

8.16.1 Grouting through the CPT push rod is possible. The grout can be pumped down the rod and out special ports near or at the cone tip. Pumping the grout inside the rod smears grout on the inside of the rod and on the signal cable. The extra cleaning time often makes this method impractical. The grout also can be pumped down an inner tube inside the rod. This usually requires a thinner grout mix to flow through a thin tube or it requires a larger tube with a larger diameter push rod requiring additional force to push.

8.16.2 It is possible to grout during rod retraction by pushing an expendable ring under the friction reducer. The cone penetrometer would be pushed through a reservoir of grout, dragging the grout down the annular area of the expendable ring. The expendable ring drops off the end when the rods are retracted allowing the grout to fill the hole from the bottom up. The ring increases the hole size, however, requiring additional push force. The outside of the push rods will need to be cleaned of the grout, but this may take less time than cleaning the inside of reentry rods.

8.16.3 It is possible to grout during rod retraction by pushing a casing over the push rod, withdrawing the push rod, and then routing through the open casing. This, too, requires a larger hole, but is often used in soft soils where the outer casing also can provide lateral rod support for the CPT rod.

8.16.4 In some cases, it is possible to simply grout the hole by pouring grout or granular bentonite into the open hole. This is normally only permitted if the hole does not extend into the water table.

## 9. Report

9.1 The methodology used to specify how data are recorded in the test data acquisition system is covered in Test Method **D5778**.

9.2 Record as a minimum the following general information:

9.3 Include information that may alter the cone penetrometer data.

9.3.1 Chemical attack of seals may cause failure and leaks or high friction if the seals become sticky. If alternate seals are used to prevent this from happening, document this information since different seal types have different friction characteristics that may affect the data.

9.3.2 The data obtained by the electronic piezocone penetrometer test is assumed to pertain to normal soils. This may not be the case, necessarily, in environmental site characterization projects. Report the presence of known tar, waste, debris, landfill deposits, and so forth, that are not normally deposited soils. For example, oily and greasy soils have less local friction, and landfills may have voids and numerous items that are not soils. Voids will be indicated by zero tip and

friction values and should be identified as such so the engineer does not think the data indicates depth counter problems. Some landfill items can be identified by sound. The breaking of metal objects or timbers, or both, produces distinct noises that can be identified and noted in the report.

9.4 The cone penetrometer process is a valuable method for deploying alternative sensors such as Practice **D6187**. An in-depth discussion of alternative sensors is beyond the scope of this practice. Report the type of sensor and data from the sensor. Report the location and physical shape of the sensor

since this may affect the cone penetrometer data. Include a complete description of the sensor technology, equipment, and procedures.

9.5 As indicated in **8.10**, include the grouting procedure and anomalies.

## 10. Keywords

10.1 cone penetrometer; cone penetrometer test; direct push; explorations; groundwater; penetration tests; piezocone; soil investigations; soundings; water sampling; well point

## REFERENCES

- (1) Manchon, R. G., "Introduction to Cone Penetrometer Testing and Ground Water Samplers," Workshop presented at the Fifth National Outdoor Action Conference on Aquifer Restoration, Ground Water Monitoring and Geophysical Methods, IT Corp., Martinez, CA, May 1991.
- (2) Smolley, M., and Kappemyer, J., "Cone Penetrometer Tests and Hydropunch Sampling—An Alternative to Monitoring Wells for Plume Detection," *Proceedings of the Hazmacon 1989 Conference*, April 18–20, 1989, Santa Clara, CA, pp. 71–80.
- (3) Auxt, J. A., and Wright, D. E., "Environmental Site Characterization in the United States Using the Cone Penetrometer," *Proceedings of CPT '95—International Symposium on Cone Penetration Testing*, Vol 2, 1995, pp. 387–392.
- (4) Lutenecker, A. J., and DeGroot, D. J., "Techniques for Sealing Cone Penetrometer Holes," *Canadian Geotechnical Journal*, Vol 32, No. 5, pp. 880–891.
- (5) Strutynsky, A., and Bergen, C., "Use of Piezometric Cone Penetration Testing and Penetrometer Ground Water Sampling for Volatile Organic Contaminant Plume Detection," *Proceedings of the National Water Well Association Petroleum Hydrocarbons Conference*, Oct. 31–Nov. 2, 1990, Houston, TX, pp. 71–84.
- (6) Berzins, N. A., "Use of the Cone Penetration Test and BAT Ground Water Monitoring System to Assess Deficiencies in Monitoring Well Data," *Proceedings of the National Ground Water Association Outdoor Action Conference*, 1992, pp. 327–341.
- (7) Practical Handbook of Environmental Site Characterization and Ground-Water Monitoring, (2006), Nielsen, David M, Editor, Taylor and Francis, New York, pg 416 -500.
- (8) Robertson, P.K., Lunne, T., and J.J.M. Powell, (1998), "Geo-environmental Applications of Penetration Testing," *Geotechnical Site Characterization, Proceedings of the First International Conference on Site Characterization—ISC-98*, Atlanta GA, AA Balkema, Rotterdam., pg 35-48.
- (9) Tumay, M.T., Acar, Y.B., and Boggess, R. (1981), "Subsurface Investigation with the Piezocone Penetrometer," ASCE Special Publication on Cone Penetration Testing and Experience, American Society of Civil Engineers, pp. 325-342.
- (10) Lunne, T., Robertson, P.K., and J.J.M. Powell, *Cone Penetration Testing in Geotechnical Practice*, (1997), Blackie Academic & Professional, London.
- (11) Elsworth, Derek, and Dae Sung Lee, 2005. Permeability Determination from On-the-Fly Piezocone Soundings, *Journal of Geotechnical and Geoenvironmental Engineering*, May, 2005, p. 643-653.
- (12) Lee, D.A, Elsworth, D., Hryciw, R, "Hydraulic Conductivity Measurement from On-the-Fly uCPT Sounding and from VisCPT," *Journal of Geotechnical and Geoenvironmental Engineering*, ASCE, Vol 134, No. 12, December 1, 2008.
- (13) Song, C.R., Voyiadjisk, G.Z., and Tumay, M.T., (1999), "Determination of Permeability of Soils Using the Multiple Piezo Cone Penetrometer," *International Journal for Numerical and Analytical Methods in Geomechanics*, Special Issue in Poroelasticity, Vol 23, pp 1609-1629.
- (14) Parez and Fauriel (1988). "Le piezocone ameliorations apportees a la reconnaissance de sols." *Revue Francaise de Geotech* 44: 13-27.
- (15) Kram, Mark L., Gary Robbins, Jessica Chau, and Amvirossious Bagtzoglou, 2008 . Detailed Hydraulic Assessment Using a High-Resolution Piezocone Coupled to the GeoVIS, Final Report, ESTCP ER-0421, April, 2008, 99pp. <http://www.clu-in.org/s.focus/c/pub/i/1558/>
- (16) Burns, Susan E, and Mayne Paul W, (1998) "Penetrometers for Soil Permeability and Chemical Detection," Geosystems Engineering Group, School of Civil and Environmental Engineering, Georgia Institute of Technology, Atlanta GA.

## SUMMARY OF CHANGES

Committee D18 has identified the location of selected changes to this practice since the last issue, D6067–96(2003), that may impact the use of this practice. (Approved May 1, 2010)

- (1) Changed the standard from a guide to a practice.
- (2) Added references to related ASTM standards on direct push soil sampling, well construction, and CPT sensors with fluorescence and encouraged the use of piezocone penetration testing in the Scope.
- (3) Added new standards on soil sampling, Laser CPT, direct push wells to Referenced Documents.
- (4) Added definitions of dissipation tests and definition in accordance with Test Method **D5778-07** in Section 3.
- (5) Added information on new methods for measuring or estimating hydraulic conductivity, new soil behavior type graphs, and new hydraulic conductivity charts based on soil behavior group in Section 4.
- (6) Replaced **Fig. 1** of the cone with a better schematic used in Test Method **D5778-07**.

*ASTM International takes no position respecting the validity of any patent rights asserted in connection with any item mentioned in this standard. Users of this standard are expressly advised that determination of the validity of any such patent rights, and the risk of infringement of such rights, are entirely their own responsibility.*

*This standard is subject to revision at any time by the responsible technical committee and must be reviewed every five years and if not revised, either reapproved or withdrawn. Your comments are invited either for revision of this standard or for additional standards and should be addressed to ASTM International Headquarters. Your comments will receive careful consideration at a meeting of the responsible technical committee, which you may attend. If you feel that your comments have not received a fair hearing you should make your views known to the ASTM Committee on Standards, at the address shown below.*

*This standard is copyrighted by ASTM International, 100 Barr Harbor Drive, PO Box C700, West Conshohocken, PA 19428-2959, United States. Individual reprints (single or multiple copies) of this standard may be obtained by contacting ASTM at the above address or at 610-832-9585 (phone), 610-832-9555 (fax), or [service@astm.org](mailto:service@astm.org) (e-mail); or through the ASTM website ([www.astm.org](http://www.astm.org)). Permission rights to photocopy the standard may also be secured from the Copyright Clearance Center, 222 Rosewood Drive, Danvers, MA 01923, Tel: (978) 646-2600; <http://www.copyright.com/>*