



Standard Test Method for Determination of Dynamic Water Absorption of Leather Surfaces¹

This standard is issued under the fixed designation D6014; the number immediately following the designation indicates the year of original adoption or, in the case of revision, the year of last revision. A number in parentheses indicates the year of last reapproval. A superscript epsilon (ϵ) indicates an editorial change since the last revision or reapproval.

1. Scope

1.1 This test method covers determining the degree of wettability of a leather surface. This test method does not apply to wet blue.

1.2 The values stated in inch-pound units are to be regarded as standard. The values given in parentheses are mathematical conversions to SI units that are provided for information only and are not considered standard.

1.3 *This standard does not purport to address all of the safety concerns, if any, associated with its use. It is the responsibility of the user of this standard to establish appropriate safety and health practices and determine the applicability of regulatory limitations prior to use.*

2. Referenced Documents

2.1 *ASTM Standards:*²

D1610 Practice for Conditioning Leather and Leather Products for Testing

2.2 *Federal Standard:*³

Federal Test Standard No. 311, Method 8151 Dynamic Water Absorption of Leather Surfaces

3. Significance and Use

3.1 This test method may be used to measure the effectiveness of water resistant treatments of light leathers such as glove and garment leather that have no finish. It can also be used to

¹ This test method is under the jurisdiction of ASTM Committee D31 on Leather and is the direct responsibility of Subcommittee D31.04 on Apparel. This test method was developed from Federal Test Method Standard No. 311, Method 8151 in cooperation with the U.S. Army Natick Research Development & Engineering Center, Natick MA and the Defense Personnel Support Center Directorate of Clothing and Textiles, Philadelphia PA.

Current edition approved Sept. 1, 2015. Published October 2015. Originally approved in 1996. Last previous edition approved in 2010 as D6014 - 00 (2010). DOI: 10.1520/D6014-00R15.

² For referenced ASTM standards, visit the ASTM website, www.astm.org, or contact ASTM Customer Service at service@astm.org. For *Annual Book of ASTM Standards* volume information, refer to the standard's Document Summary page on the ASTM website.

³ Available from Superintendent of Documents, U.S. Government Printing Office, Washington, DC 20402.

measure the water absorption capacity of insole materials thus providing a gage for predicting foot comfort or discomfort.

4. Apparatus

4.1 *Washing Machine*—A Launder-Ometer,⁴ or an assembly of apparatus capable of similar test conditions (see **Note 1**). In either machine, 1-pt (500-mL) specimen containers are held with their bases toward a horizontal shaft and 2 in. (50 mm) out from its center of rotation. Speed of rotation shall be 40 to 45 rpm. Provision shall be made for maintaining the initial temperature of the specimen containers throughout the test.

NOTE 1—A motor-driven assembly, designed to hold 1-pt (500-mL) specimen containers so that they are relative to the axis of the motor shaft in the same way as in the Launder-Ometer, can be used.⁵ The entire assembly, fitted with specimen containers, shall be turned at 40 to 45 rpm inside a simple boxlike container. Such an apparatus is illustrated in **Figs. 1 and 2**.

4.2 *Specimen Containers*,⁶ glass or stainless steel, 1-pt (500-mL), washer, and cap, or Mason jar,⁷ top inside diameter 2 $\frac{3}{8}$ in. (60.3 mm) and 4 in. (100 mm) high including thread, with threaded lid and insert.

4.3 *Balance*, sensitive to 0.01 g or better (high speed balance preferred for readings to nearest 0.01 g).

4.4 *Roll of Pressure-Sensitive Adhesive (Both Sides) Paper*, 1 in. (25.4 mm) wide (for light leathers).

4.5 *Rubber Rings*, 0.8 to 1.6 mm thick, Type A durometer hardness 50 to 80, inner diameter 2 $\frac{1}{4}$ in. (57 mm), to fit into lids (for light leathers).

⁴ The sole source of supply of the apparatus known to the committee at this time is Atlas Electric Devices Company, 4114 No. Ravenswood Ave., Chicago, IL 60613. If you are aware of alternative suppliers, please provide this information to ASTM Headquarters. Your comments will receive careful consideration at a meeting of the responsible technical committee, which you may attend.

⁵ Available from ASTM International Headquarters. Order Adjunct No. ADJD2096. Original adjunct produced in 1962. Adjunct last revised in 2009.

⁶ The sole source of supply of the apparatus known to the committee at this time is Parkway Plastics, P.O. Box 475, Piscataway, NJ 08854. If you are aware of alternative suppliers, please provide this information to ASTM Headquarters. Your comments will receive careful consideration at a meeting of the responsible technical committee, which you may attend.

⁷ Mason jars and lids with inserts may be purchased at any hardware store.



FIG. 1 Washing Machine

4.6 *Dies*, suitable to cut rubber rings and specimens.

5. Test Specimen

5.1 The test specimen shall be a disc of leather no less than $2\frac{1}{32}$ in. (67.5 mm) and no more than $2\frac{3}{4}$ in. (70 mm) in diameter, cut by a die from the sample unit of leather.

6. Procedure

6.1 Unless otherwise specified in the material specification, carry out the test under standard conditions specified in Practice **D1610**.

6.2 Unless otherwise specified in the material specification, the grain side of the specimen shall face the water surface.

6.3 For testing light leathers, mount two strips of the pressure-sensitive adhesive paper cross-wise on the surface of the insert. The insert can be reused many times before these adhesive strips required replacement. Place the insert in the lid,

weigh the specimen and place it on the lid, and lay the rubber ring on the specimen. For testing heavy and stiff leather, the insert and rubber ring are not required.

6.4 Tightly screw the assembly onto the plastic container containing 50 cc, or mason jar containing 100 cc, of fresh distilled water at 23°C. Immediately mount the assembly on the tumbling machine and run the machine at 40 to 45 rpm. When either plastic or glass containers are used, place approximately equal numbers of containers at opposite ends of the tumbler. Mount the containers with the lids toward the axis of rotation. The distance from the axis of rotation to the surface of each specimen shall be $3\frac{3}{4} \pm \frac{1}{2}$ in. (95.25 ± 12.7 mm). Place no more than four plastic containers at each end of the machine.

6.5 After 40 min of tumbling, lightly blot the specimen with a paper towel after being lifted from the lid, and weigh grain side down.

6.6 If any container leaks during the tumbling operation, stop the test and remove the leaky container with specimen. If other specimens have become wet because of the leak, remove the containers containing these specimens also. Immediately restart the tumbler, and complete the test. Do not retest the same specimen. Prepare a new specimen and test again using caution to prevent leaking. Test is valid only when the container does not leak. A leaky container can be detected by the presence of moisture on the outside of the container and a large volume loss of water during tumbling.

7. Report

7.1 Report the water absorbed by the specimen during tumbling to the nearest 0.01 g.

8. Precision and Bias

8.1 This test method is adopted from Federal Test Standard No. 311, Method 8151 where it has long been in use and was approved for publication before the inclusion of precision and bias statements was mandated. The user is cautioned to verify by the use of reference materials, if available, that the precision and bias (or reproducibility) of this test method is adequate for the contemplated use.

9. Keywords

9.1 comfort; leather; water absorption; wettability

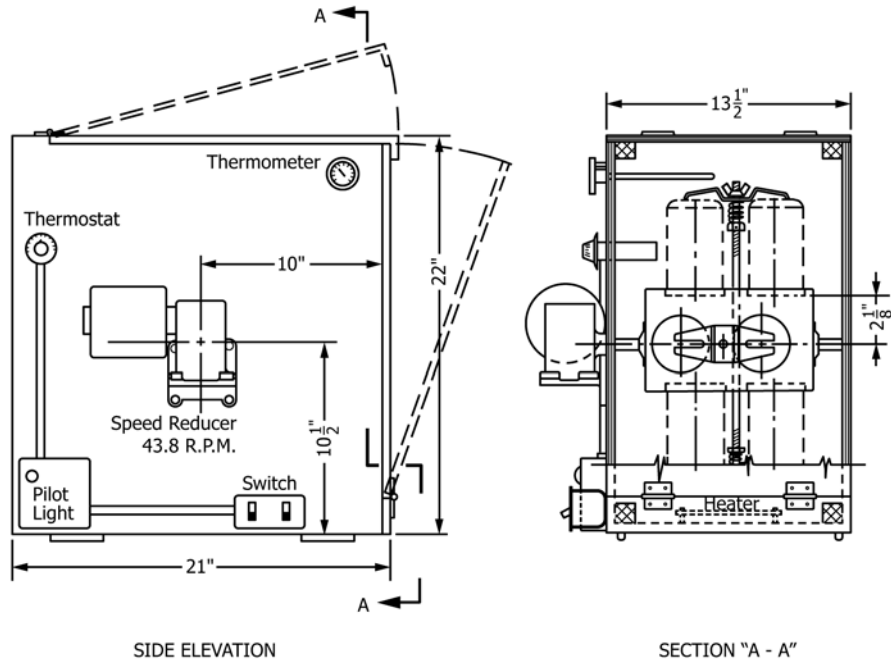

SIDE ELEVATION

SECTION "A - A"

in.	2 1/8	10	10 1/2	13 1/2	21	22
mm	54	254	267	343	533	559

FIG. 2 Diagram of Washing Machine

ASTM International takes no position respecting the validity of any patent rights asserted in connection with any item mentioned in this standard. Users of this standard are expressly advised that determination of the validity of any such patent rights, and the risk of infringement of such rights, are entirely their own responsibility.

This standard is subject to revision at any time by the responsible technical committee and must be reviewed every five years and if not revised, either reapproved or withdrawn. Your comments are invited either for revision of this standard or for additional standards and should be addressed to ASTM International Headquarters. Your comments will receive careful consideration at a meeting of the responsible technical committee, which you may attend. If you feel that your comments have not received a fair hearing you should make your views known to the ASTM Committee on Standards, at the address shown below.

This standard is copyrighted by ASTM International, 100 Barr Harbor Drive, PO Box C700, West Conshohocken, PA 19428-2959, United States. Individual reprints (single or multiple copies) of this standard may be obtained by contacting ASTM at the above address or at 610-832-9585 (phone), 610-832-9555 (fax), or service@astm.org (e-mail); or through the ASTM website (www.astm.org). Permission rights to photocopy the standard may also be secured from the Copyright Clearance Center, 222 Rosewood Drive, Danvers, MA 01923, Tel: (978) 646-2600; http://www.copyright.com/