



# Standard Test Method for Determination of Area Stability of Leather to Laundering<sup>1</sup>

This standard is issued under the fixed designation D6013; the number immediately following the designation indicates the year of original adoption or, in the case of revision, the year of last revision. A number in parentheses indicates the year of last reapproval. A superscript epsilon ( $\epsilon$ ) indicates an editorial change since the last revision or reapproval.

## 1. Scope

1.1 This test method<sup>2</sup> covers the determination of launderability of dyed leathers with or without a pigment finish. This test method does not apply to wet blue.

1.2 The values stated in inch-pound units are to be regarded as the standard. The values given in parentheses are for information only.

1.3 *This standard does not purport to address all of the safety concerns, if any, associated with its use. It is the responsibility of the user of this standard to establish appropriate safety and health practices and determine the applicability of regulatory limitations prior to use.*

## 2. Referenced Documents

### 2.1 ASTM Standards:<sup>3</sup>

**D1610 Practice for Conditioning Leather and Leather Products for Testing**

## 3. Significance and Use

3.1 The procedure is primarily intended to evaluate the ability of a leather specimen to withstand fixed, and rather strenuous, laundering conditions. This test method is not intended as a recommended washing procedure, neither household nor commercial. The resulting area stability is determined.

<sup>1</sup> This test method is under the jurisdiction of ASTM Committee D31 on Leather and is the direct responsibility of Subcommittee D31.04 on Apparel.

Current edition approved April 1, 2010. Published May 2010. Originally approved in 1996. Last previous edition approved in 2005 as D6013 - 00 (2005). DOI: 10.1520/D6013-00R10.

<sup>2</sup> This test method was developed from Federal Test Method Standard No. 311 Method 3041.1 in cooperation with the U.S. Army Natick Research Development and Engineering Center, Natick, MA, and the Defense Personnel Support Center Directorate of Clothing and Textiles, Philadelphia, PA.

<sup>3</sup> For referenced ASTM standards, visit the ASTM website, [www.astm.org](http://www.astm.org), or contact ASTM Customer Service at [service@astm.org](mailto:service@astm.org). For *Annual Book of ASTM Standards* volume information, refer to the standard's Document Summary page on the ASTM website.

## 4. Apparatus<sup>4</sup>

4.1 *Washing Machine*—A Launder-Ometer,<sup>5</sup> or an assembly of apparatus capable of similar test conditions (see Note). In either machine, 1-pt (500-mL) specimen containers are held with their bases toward a horizontal shaft and 2 in. (50 mm) out from its center of rotation. Speed of rotation shall be 40 to 45 rpm. Provision shall be made for maintaining the initial temperature of the specimen containers throughout the test. Additional agitation shall be provided by ¼-in. (6.4-mm) stainless steel balls in the specimen containers. Apparatus is illustrated in **Figs. 1-3**.

NOTE 1—A motor-driven assembly, designed to hold 1-pt (500-mL) specimen containers so that they are relative to the axis of the motor shaft in the same way as in the Launder-Ometer, can be used.<sup>5</sup> The entire assembly, fitted with specimen containers, shall be turned at 40 to 45 rpm inside a simple boxlike container which is heated at 120°F (49°C) with thermostatic control. Thus, heat loss from the preheated contents of the specimen containers is held at a minimum during the 30-min washing periods. Such an apparatus is illustrated in **Figs. 4 and 5**.

4.2 *Stainless Steel Balls*, type 316, ¼ in. (6 mm) diameter.

4.3 *Steel or Glass Jar*, 1 pt (0.5 L), with washer and cap.

4.4 *Circulating-air Oven*, capable of maintaining the required temperature of 120 ± 2°F (49 ± 1°C).

4.5 *Blotting Paper*,<sup>6</sup>(laboratory) (see 7.2).

<sup>4</sup> The leather washing apparatus drawing is available from ASTM Headquarters, 100 Barr Harbor Drive, W. Conshohocken, PA 19428-2959. Request Adjunct ADJD6013.

<sup>5</sup> The sole source of supply of the apparatus known to the committee at this time is Atlas Electric Devices Co., 4114 N. Ravenswood Ave., Chicago, IL 60613. If you are aware of alternative suppliers, please provide this information to ASTM Headquarters. Your comments will receive careful consideration at a meeting of the responsible technical committee, which you may attend.

<sup>6</sup> The sole source of supply of the apparatus known to the committee at this time is Standard Paper Manufacturing Co., P.O. Box 1554, Richmond, VA 23212. If you are aware of alternative suppliers, please provide this information to ASTM Headquarters. Your comments will receive careful consideration at a meeting of the responsible technical committee, which you may attend.

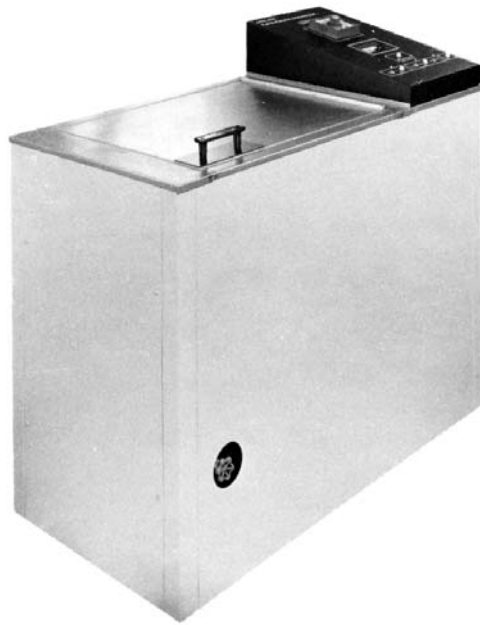

FIG. 1 Launder-Ometer



FIG. 2 Launder-Ometer Stainless Steel Specimen Containers

4.6 *Metal Die*, for cutting the specimen to the required dimensions.

4.7 *Soap Solution*,<sup>7</sup> prepared by dissolving 5 g of standard neutral chip soap in 1 L of distilled water (see 7.3).

## 5. Test Specimen

5.1 The specimen shall be a square of leather 2.0 by 2.0 in. (51 by 51 mm) cut from the sample unit of leather. Three specimens from each sample unit shall be tested.

<sup>7</sup> The sole source of supply of the apparatus known to the committee at this time is AATCC National Headquarters, P.O. Box 12215, Research Triangle Park, NC 22709. If you are aware of alternative suppliers, please provide this information to ASTM Headquarters. Your comments will receive careful consideration at a meeting of the responsible technical committee, which you may attend.

## 6. Procedure

6.1 Unless otherwise specified, perform this test in accordance with standard atmospheric conditions (see Practice D1610). Weigh the conditioned samples to the nearest 0.1 g.

6.2 Make two measurements of each dimension of the specimen and average them. Make the measurements 13 mm in from the edges of the specimen. Indelibly mark the grain surface of the specimen to indicate the points of measurement. Use the average measurement to determine the original area of the specimen, and record this area as A. (The known dimensions of the die may be used instead of actually measuring the specimen. When this option is taken, the specimen shall still be indelibly marked at the points of measurement indicated above.)

6.3 Add three specimens and twenty stainless steel balls to a 1-pt jar together with 150 mL of a soap solution that has been preheated to  $120 \pm 2^\circ\text{F}$  ( $49 \pm 1^\circ\text{C}$ ).

6.4 Seal the jars and clamp them into the rotor of a washing machine. Run the apparatus at 40 to 45 rpm for 30 min at  $120 \pm 2^\circ\text{F}$  ( $49 \pm 1^\circ\text{C}$ ).

6.5 Remove the jars and pour the soap solution from the jars through a sieve to avoid losing the steel balls and specimens. Then place the specimens flesh side down on a pad consisting of two 10 by 10-in. (25.4 by 25.4-cm) blotting papers, and cover them with a pad of two additional blotting papers of the same type. Place a non-absorbent flat rigid plate large enough to cover the blotters on the cover blotter. If necessary, place a weight on the plate so as to subject the specimens to a  $10 \text{ g/cm}^2$  load for 5 min. At the end of this period, remove the load and transfer the specimens to the pint container previously filled with water preheated to  $120 \pm 2^\circ\text{F}$  ( $49 \pm 1^\circ\text{C}$ ). The volume of water in millilitres shall be approximately 20 times the initial weight of the conditioned specimens in grams.

6.6 Seal, clamp, and rotate jars for 30 min in washing machine. Remove the water and squeeze the specimens by hand and spread next to each other on a flat noncorrosive rigid plate. No specimen shall be closer than  $\frac{1}{2}$  in. (12.7 mm) to the others.

6.7 Place the plate with specimens in a pre-heated circulating air oven for 30 min at  $120 \pm 2^\circ\text{F}$  ( $49 \pm 1^\circ\text{C}$ ). At the end of 30 min, return the dried specimens to the pint jars, 3 specimens per jar, together with the steel balls and 100 mL of the soap solution preheated to  $120 \pm 2^\circ\text{F}$  ( $49 \pm 1^\circ\text{C}$ ). Repeat the entire procedure again. After the specimens have been removed from the oven the second time, return them to the pint jars, 3 specimens per jar, together with the steel balls and 50 mL of the soap solution preheated to  $120 \pm 2^\circ\text{F}$  ( $49 \pm 1^\circ\text{C}$ ). Repeat the entire procedure a third time, except do not squeeze the specimens by hand or dried in the oven, after being tumbled in the pre-heated water. Instead, the specimens shall be placed grain side up on a flat noncorrosive rigid surface and allowed to dry under standard conditions for 48 h.

6.8 Take two measurements in one dimension, average them, and record the average as B. Take two measurements in the other dimension, average them, and record the average as C. The measurements will be made at the indelibly marked

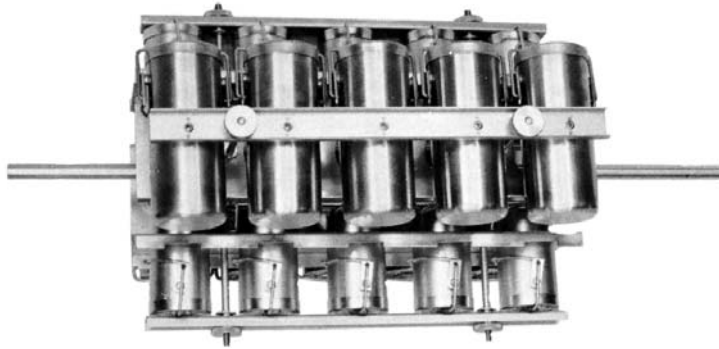

FIG. 3 Specimen Containers Mounted on Launder-Ometer Rotor



FIG. 4 Washing Machine, Heated Air Bath

points of measurement described in 6.2. The averages shall be calculated to the nearest 0.02 in. (0.1 mm). Calculate the average area change as follows:

$$\text{Percent area change} = \frac{A - (B \times C) \times 100}{A} \quad (1)$$

where:

- A = original area of the specimen (can be calculated from the known dimensions of the die),
- B = average of two measurements in one dimension of the specimen, and
- C = average of two measurements in the other dimension of test specimen.

6.8.1 In the event of increase in area of the test specimen, the calculations shall be made as follows:

$$\text{Percent area change} = \frac{(B \times C) - A \times 100}{A} \quad (2)$$

## 7. Report

7.1 Report area change to the nearest 0.1 %.

## 8. Precision and Bias

8.1 *Precision*—The following criteria may be used to judge the acceptability of the results if at least 15 units have been measured:

8.1.1 Results by the same operator on duplicate specimen, same skin, should not be considered suspect unless the coefficient of variation exceeds 2 %.

8.1.2 Results of two laboratories on duplicate specimens, same skin, should not be considered suspect unless the coefficient of variation exceeds 2 %.

8.2 *Bias*—No justifiable statement on bias can be made since the true value of area of leather test specimens cannot be established by an accepted reference method.

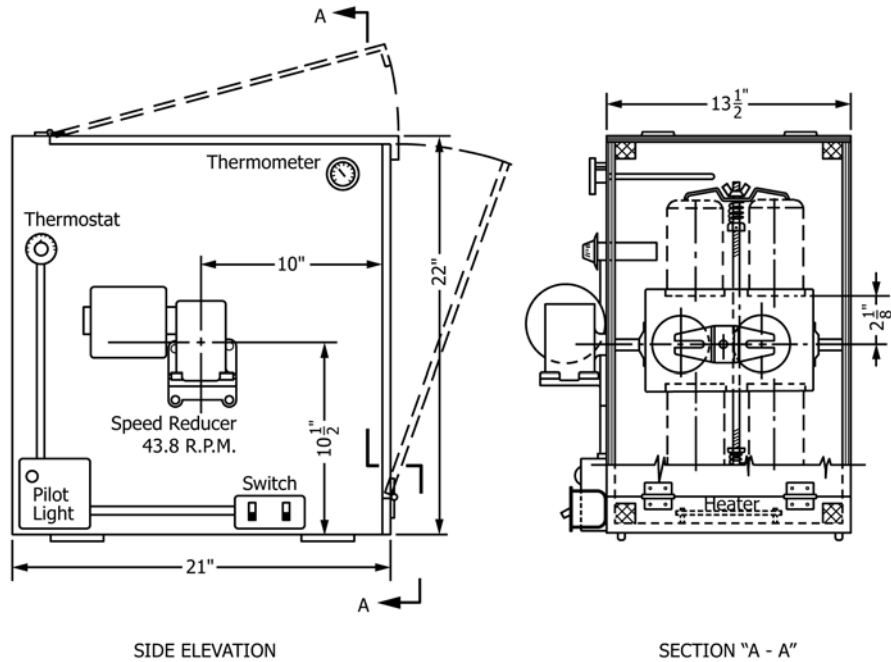

SIDE ELEVATION

SECTION "A - A"

in.	2 1/8	10	10 1/2	13 1/2	21	22
mm	54	254	267	343	533	559

FIG. 5 Diagram of Washing Machine

## 9. Keywords

9.1 area change; area stability; laundering; leather; measuring area

*ASTM International takes no position respecting the validity of any patent rights asserted in connection with any item mentioned in this standard. Users of this standard are expressly advised that determination of the validity of any such patent rights, and the risk of infringement of such rights, are entirely their own responsibility.*

*This standard is subject to revision at any time by the responsible technical committee and must be reviewed every five years and if not revised, either reapproved or withdrawn. Your comments are invited either for revision of this standard or for additional standards and should be addressed to ASTM International Headquarters. Your comments will receive careful consideration at a meeting of the responsible technical committee, which you may attend. If you feel that your comments have not received a fair hearing you should make your views known to the ASTM Committee on Standards, at the address shown below.*

*This standard is copyrighted by ASTM International, 100 Barr Harbor Drive, PO Box C700, West Conshohocken, PA 19428-2959, United States. Individual reprints (single or multiple copies) of this standard may be obtained by contacting ASTM at the above address or at 610-832-9585 (phone), 610-832-9555 (fax), or service@astm.org (e-mail); or through the ASTM website (www.astm.org). Permission rights to photocopy the standard may also be secured from the Copyright Clearance Center, 222 Rosewood Drive, Danvers, MA 01923, Tel: (978) 646-2600; http://www.copyright.com/*