



Standard Guide for Direct-Push Groundwater Sampling for Environmental Site Characterization¹

This standard is issued under the fixed designation D6001; the number immediately following the designation indicates the year of original adoption or, in the case of revision, the year of last revision. A number in parentheses indicates the year of last reapproval. A superscript epsilon (ϵ) indicates an editorial change since the last revision or reapproval.

1. Scope

1.1 This guide covers a review of methods for sampling groundwater at discrete points or in increments by insertion of sampling devices by static force or impact without drilling and removal of cuttings. By directly pushing the sampler, the soil is displaced and helps to form an annular seal above the sampling zone. Direct-push water sampling can be one time, or multiple sampling events. Methods for obtaining water samples for water quality analysis and detection of contaminants are presented.

1.2 Direct-push methods of water sampling are used for groundwater quality studies. Water quality may vary at different depths below the surface depending on geohydrologic conditions. Incremental sampling or sampling at discrete depths is used to determine the distribution of contaminants and to more completely characterize geohydrologic environments. These investigations are frequently required in characterization of hazardous and toxic waste sites.

1.3 Direct-push methods can provide accurate information on the distribution of water quality if provisions are made to ensure that cross-contamination or linkage between water bearing strata are not made. Discrete point sampling with a sealed (protected) screen sampler, combined with on-site analysis of water samples, can provide the most accurate depiction of water quality conditions at the time of sampling. Direct-push water sampling with exposed-screen sampling devices may be useful and are considered as screening tools depending on precautions taken during testing. Exposed screen samplers may require development or purging depending on sampling and quality assurance plans. Results from direct-push investigations can be used to guide placement of permanent groundwater monitoring wells and direct remediation efforts. Multiple sampling events can be performed to depict conditions over time. Use of double tube tooling, where the outer

push tube seals the hole, prevents the sampling tools from coming in contact with the formation, except at the sampling point.

1.4 Field test methods described in this guide include installation of temporary well points, and insertion of water samplers using a variety of insertion methods. Insertion methods include: (1) soil probing using combinations of impact, percussion, or vibratory driving with or without additions of smooth static force; (2) smooth static force from the surface using hydraulic cone penetrometer (Guide [D6067](#)) or drilling equipment (Guide [D6286](#)), and incremental drilling combined with direct-push water sampling events. Under typical incremental drilling operations, samplers are advanced with assistance of drilling equipment by smooth hydraulic push, or mechanical impacts from hammers or other vibratory equipment. Direct-push water sampling maybe combined with other sampling methods (Guide [D6169](#)) in drilled holes. Methods for borehole abandonment by grouting are also addressed.

1.5 Direct-push water sampling is limited to soils that can be penetrated with available equipment. In strong soils damage may result during insertion of the sampler from rod bending or assembly buckling. Penetration may be limited, or damage to samplers or rods can occur in certain ground conditions, some of which are discussed in [5.6](#). Information in this procedure is limited to sampling of saturated soils in perched or saturated groundwater conditions. Some soil formations do not yield water in a timely fashion for direct-push sampling. In the case of unyielding formations direct-push soil sampling can be performed (Guide [D6282](#)).

1.6 This guide does not address installation of permanent water sampling systems such as those presented in Practice [D5092](#). Direct-push monitoring wells for long term monitoring are addressed in Guide [D6724](#) and Practice [D6725](#).

1.7 Direct-push water sampling for geoenvironmental exploration will often involve safety planning, administration, and documentation.

1.8 *This guide does not purport to address all aspects of exploration and site safety. It is the responsibility of the user of this guide to establish appropriate safety and health practices and determine the applicability of regulatory limitations before its use.*

¹ This guide is under the jurisdiction of ASTM Committee [D18](#) on Soil and Rock and is the direct responsibility of Subcommittee [D18.21](#) on Groundwater and Vadose Zone Investigations.

Current edition approved Jan. 15, 2012. Published December 2012. Originally approved in 1996. Last previous edition approved in 2005 as D6001 – 05. DOI: 10.1520/D6001-05R12.

1.9 This guide offers an organized collection of information or a series of options and does not recommend a specific course of action. This document cannot replace education or experience and should be used in conjunction with professional judgment. Not all aspects of this guide may be applicable in all circumstances. This ASTM standard is not intended to represent or replace the standard of care by which the adequacy of a given professional service must be judged, nor should this document be applied without consideration of a project's many unique aspects. The word "Standard" in the title of this document means only that the document has been approved through the ASTM consensus process.

2. Referenced Documents

2.1 ASTM Standards:²

- D653 Terminology Relating to Soil, Rock, and Contained Fluids
- D2488 Practice for Description and Identification of Soils (Visual-Manual Procedure)
- D4448 Guide for Sampling Ground-Water Monitoring Wells
- D4750 Test Method for Determining Subsurface Liquid Levels in a Borehole or Monitoring Well (Observation Well) (Withdrawn 2010)³
- D5088 Practice for Decontamination of Field Equipment Used at Waste Sites
- D5092 Practice for Design and Installation of Groundwater Monitoring Wells
- D5254 Practice for Minimum Set of Data Elements to Identify a Ground-Water Site
- D5314 Guide for Soil Gas Monitoring in the Vadose Zone
- D5434 Guide for Field Logging of Subsurface Explorations of Soil and Rock
- D5474 Guide for Selection of Data Elements for Groundwater Investigations
- D5521 Guide for Development of Groundwater Monitoring Wells in Granular Aquifers
- D5730 Guide for Site Characterization for Environmental Purposes With Emphasis on Soil, Rock, the Vadose Zone and Groundwater (Withdrawn 2013)³
- D5778 Test Method for Electronic Friction Cone and Piezocone Penetration Testing of Soils
- D5903 Guide for Planning and Preparing for a Groundwater Sampling Event
- D6067 Practice for Using the Electronic Piezocone Penetrometer Tests for Environmental Site Characterization
- D6089 Guide for Documenting a Groundwater Sampling Event
- D6235 Practice for Expedited Site Characterization of Vadose Zone and Groundwater Contamination at Hazardous Waste Contaminated Sites
- D6452 Guide for Purging Methods for Wells Used for Groundwater Quality Investigations

- D6517 Guide for Field Preservation of Groundwater Samples
- D6564 Guide for Field Filtration of Groundwater Samples
- D6634 Guide for Selection of Purging and Sampling Devices for Groundwater Monitoring Wells
- D6724 Guide for Installation of Direct Push Groundwater Monitoring Wells
- D6725 Practice for Direct Push Installation of Prepacked Screen Monitoring Wells in Unconsolidated Aquifers
- D6771 Practice for Low-Flow Purging and Sampling for Wells and Devices Used for Ground-Water Quality Investigations (Withdrawn 2011)³
- D6911 Guide for Packaging and Shipping Environmental Samples for Laboratory Analysis

2.2 Drilling Methods:²

- D5781 Guide for the Use of Dual-Wall Reverse-Circulation Drilling for Geoenvironmental Exploration and the Installation of Subsurface Water-Quality Monitoring Devices
- D5782 Guide for the Use of Direct Air-Rotary Drilling for Geoenvironmental Exploration and the Installation of Subsurface Water-Quality Monitoring Devices
- D5783 Guide for the Use of Direct Rotary Drilling with Water-Based Drilling Fluid for Geoenvironmental Exploration and the Installation of Subsurface Water-Quality Monitoring Devices
- D5784 Guide for the Use of Hollow-Stem Augers for Geoenvironmental Exploration and the Installation of Subsurface Water-Quality Monitoring Devices
- D5875 Guide for the Use of Cable-Tool Drilling and Sampling Methods for Geoenvironmental Explorations and Installation of Subsurface Water-Quality Monitoring Devices
- D5876 Guide for the Use of Direct Rotary Wireline Casing Advancement Drilling Methods for Geoenvironmental Exploration and the Installation of Subsurface Water-Quality Monitoring Devices
- D6286 Guide to the Selection of Drilling Methods for Environmental Site Characterization

2.3 Soil Sampling:²

- D4700 Guide for Soil Sampling from the Vadose Zone
- D6169 Guide to the Selection of Soil and Rock Sampling Devices Used With Drilling Rigs for Environmental Investigations
- D6282 Guide for Direct-Push Soil Sampling for Environmental Site Characterization

3. Terminology

3.1 Terminology used within this guide is in accordance with Terminology D653 with the addition of the following:

3.2 *Definitions in Accordance with Practice D5092:*

3.2.1 *bailer*—a hollow tubular receptacle used to facilitate removal of fluid from a well or borehole.

3.2.2 *borehole*—a circular open or uncased subsurface hole created by drilling.

3.2.3 *casing*—pipe, finished in sections with either threaded connections or beveled edges to be field welded, which is installed temporarily or permanently to counteract caving, to

² For referenced ASTM standards, visit the ASTM website, www.astm.org, or contact ASTM Customer Service at service@astm.org. For *Annual Book of ASTM Standards* volume information, refer to the standard's Document Summary page on the ASTM website.

³ The last approved version of this historical standard is referenced on www.astm.org.

advance the borehole, or to isolate the interval being monitored, or combination thereof.

3.2.4 *caving; sloughing*—the inflow of unconsolidated material into a borehole that occurs when the borehole walls lose their cohesive strength.

3.2.5 *centralizer*—a device that helps in the centering of a casing or riser within a borehole or another casing.

3.2.6 *jetting*—when applied as a drilling method, water is forced down through the drill rods or riser pipe and out through the end openings. The jetting water then transports the generated cuttings to the ground surface in the annulus of the drill rods or casing and the borehole. The term jetting may also refer to a well development technique.

3.2.7 *PTFE tape*—joint sealing tape composed of polytetrafluorethylene.

3.2.8 *well screen*—a filtering device used to retain the primary or natural filter pack; usually a cylindrical pipe with openings of uniform width, orientation, and spacing.

3.3 *Definitions of Terms Specific to This Standard:*

3.3.1 *assembly length*—length of sampler body and riser pipes.

3.3.2 *bentonite*—the common name for drilling fluid additives and well construction products consisting mostly of naturally occurring sodium montmorillonite. Some bentonite products have chemical additives that may affect water quality analyses (see 9.3.3).

3.3.3 *direct-push sampling*—sampling devices that are directly inserted into the soil to be sampled without drilling or borehole excavation.

3.3.4 *drill hole*—a cylindrical hole advanced into the subsurface by mechanical means; also, known as borehole or boring.

3.3.5 *effective screen length*—the length of a screen open or exposed to water bearing strata.

3.3.6 *effective seal length*—the length of soil above the well screen that is in intimate contact with the riser pipe and prevents connection of the well screen with groundwater from other zones.

3.3.7 *grab sampling*—the process of collecting a sample of fluid exposed to atmospheric pressure through the riser pipe with bailers or other methods that may include pumping; also known as batch sampling.

3.3.8 *incremental drilling and sampling*—insertion method where rotary drilling and sampling events are alternated for incremental sampling. Incremental drilling is often needed to penetrate harder or deeper formations.

3.3.9 *percussion driving*—insertion method where rapid hammer impacts are performed to insert the sampling device. The percussion is normally accompanied with application of static down force.

3.3.10 *push depth*—the depth below a ground surface datum that the end or tip of the direct-push water sampling device is inserted.

4. Summary of Guide

4.1 Direct-push water sampling consists of pushing a protected well screen to a known depth, opening the well screen over a known interval, and sampling water from the interval. A well point with an exposed screen can also be pushed with understanding of potential cross-contamination effects and purging requirements considered. A sampler with constant outside diameter is inserted directly into the soil by hydraulic jacking or hammering until sufficient riser pipe is seated into the soil to ensure a seal. Protected well screens can be exposed by retraction of riser pipes. While the riser is seated in the soil, water samples can be taken, and water injection or pressure measurements may be performed.

5. Significance and Use

5.1 Direct-push water sampling is an economical method for obtaining discrete groundwater samples without the expense of permanent monitoring well installation (1-6).⁴ This guide can be used to profile potential groundwater contamination with depth by performing repetitive sampling events. Direct-push water sampling is often used in expedited site characterization (Practice D6235). Soils to be sampled must be permeable to allow filling of the sampler in a relatively short time. The zone to be sampled can be isolated by matching well screen length to obtain discrete samples of thin aquifers. Use of these sampling techniques will result in more detailed characterization of sites containing multiple aquifers. By inserting a protected sampling screen in direct contact with soil and with watertight risers, initial well development (Guide D5521) and purging of wells (Guide D6452) may not be required for the first sampling event. Discrete water sampling, combined with knowledge of location and thickness of target aquifers, may better define conditions in thin multiple aquifers than monitoring wells with screened intervals that can intersect and allow for intercommunication of multiple aquifers (4,6,7,8,9). Direct-push sampling performed without knowledge of the location and thickness of target aquifers can result in sampling of the wrong aquifer or penetration through confining beds.

5.2 For sites that allow surface push of the sampling device, discrete water sampling is often performed in conjunction with the cone penetration test (Test Method D6067) (4-8), which is often used for stratigraphic mapping of aquifers, and to delineate high-permeability zones. In such cases, direct-push water sampling is normally performed close to cone holes. In complex alluvial environments, thin aquifers may vary in continuity such that water sampling devices may not intersect the same layer at equivalent depths as companion cone penetrometer holes.

5.3 Water sampling chambers may be sealed to maintain in situ pressures and to allow for pressure measurements and permeability testing (6,8,11). Sealing of samples under pressure may reduce the possible volatilization of some organic compounds. Field comparisons may be used to evaluate any systematic errors in sampling equipments and methods. Comparison studies may include the need for pressurizing samples,

⁴ The boldface numbers in parentheses refer to a list of references at the end of this guide.

or the use of vacuum to extract fluids more rapidly from low hydraulic conductivity soils (8.1.5.3).

5.4 Degradation of water samples during handling and transport can be reduced if discrete water sampling events with protected screen samplers are combined with real time field analysis of potential contaminants. In limited studies, researchers have found that the combination of discrete protected screen sampling with onsite field analytical testing provide accurate data of aquifer water quality conditions at the time of testing (4,6). Direct-push water sampling with exposed screen sampling devices, which may require development or purging, are considered as screening tools depending on precautions that are taken during testing.

5.5 A well screen may be pushed into undisturbed soils at the base of a drill hole and backfilled to make permanent installed monitoring wells. Procedures to complete direct-push wells as permanent installations are given in Practice D6725 and Guide D6724.

5.6 In difficult driving conditions, penetrating to the required depth to ensure sealing of the sampler well screen may not be possible. If the well screen cannot be inserted into the soil with an adequate seal, the water-sampling event would require sealing in accordance with Practice D5092 to isolate the required aquifer. Selection of the appropriate equipment and methods to reach required depth at the site of concern should be made in consultation with experienced operators or manufacturers. If there is no information as to the subsurface conditions, initial explorations consisting of penetration-resistance tests, such as Test Method D6067, or actual direct-push testing trials can be performed to select the appropriate testing system.

5.6.1 Typical penetration depths for a specific equipment configuration depend on many variables. Some of the variables are the driving system, the diameter of the sampler and riser pipes, and the resistance of the materials.

5.6.2 Certain subsurface conditions may prevent sampler insertion. Penetration is not possible in hard rock and usually not possible in softer rocks such as claystones and shales. Coarse particles such as gravels, cobbles, and boulders may be difficult to penetrate or cause damage to the sampler or riser pipes. Cemented soil zones may be difficult to penetrate depending on the strength and thickness of the layers. If layers are present that prevent direct-push from the surface, the rotary or percussion drilling methods (Guide D6286) can be employed to advance a boring through impeding layers to reach testing zones.

5.6.3 Driving systems are generally selected based on required testing depths and the materials to be penetrated. For systems using primarily static reaction force to insert the sampler, depth will be limited by the reaction weight of the equipment and penetration resistance of the material. The ability to pull back the rod string is also a consideration. Impact or percussion soil probing has an advantage of reducing the reaction weight required for penetration. Penetration capability in clays may be increased by reducing rod friction by enlarging tips or friction reducers. However, over reaming of the hole may increase the possibility of rod buckling and may allow for

communication of differing groundwater tables. Hand-held equipment is generally used on very shallow investigations, typically less than 5-m depth, but depths on the order of 10 m have been reached in very soft lacustrine clays. Intermediate size driving systems, such as small truck-mounted hydraulic-powered push and impact drivers, typically work within depth ranges from 5 to 30 m. Heavy static-push cone penetrometer vehicles, such as 20-ton trucks, typically work within depth ranges from 15 to 45 m, and also reach depth ranges on the order of 10² m in soft ground conditions. Drilling methods (Guide D6286) using drilling and incremental sampling are frequently used in all depth ranges and can be used to reach depths on the order of 103 m.

NOTE 1—Users and manufacturers cannot agree on depth ranges for different soil types. Users should consult with experienced producers and manufacturers to determine depth capability for their site conditions.

5.7 Combining multiple-sampling events in a single-sample chamber without decontamination (Practices D5088) is generally unacceptable. In this application, purging of the chamber should be performed to ensure isolation of the sampling event. Purging should be performed by removing several volumes of fluid until new chemical properties have been stabilized or elements are flushed with fluid of known chemistry. Purging requirements may depend upon the materials used in the sampler and the sampler design (Guide D6634).

6. Apparatus

6.1 *General*—A direct-push sampling system consists of a tip; well screen; chambers, if present; and riser pipes extending to the surface. Direct-push water sampling equipment can be grouped into two classes, either with a sealed protected screen or exposed screen (see 6.2). There are also two types of drive systems, single tube and double tube (see 6.4).

6.2 Samplers with sealed screens depend on the seal to avoid exposure of the sampling interval to soil or water from other layers. They can be considered as accurate point-source detectors. They are normally decontaminated between sampling events. Exposed-screen samplers may require purging and development and as such are considered as screening devices for profiling relative degrees of contamination.

6.2.1 *Exposed-Screen Samplers*—Some direct-push samplers may consist of a simple exposed well screen and riser pipe that allows grab sampling with bailers or pumps. An example of this arrangement is the simple push or well point shown in Fig. 1 (12). The practice of jetting well points is often not acceptable due to the large quantities of water used for insertion and the resulting potential for disturbance and dilution in the aquifer. If water is used for insertion, knowing the chemical constituents in the water may be necessary. Bias may be possible if an exposed-screen sampler is pushed through multiple contaminated layers. If exposed-screen well points are pushed through predrilled holes the screen and riser may fill with water present in the drill hole and require purging before sampling. One form of exposed screen sampler has been developed for multiple sampling events as an exposed tip is advanced (13,14). This multiple event “groundwater profiler” injects distilled water out of the ports in between sampling

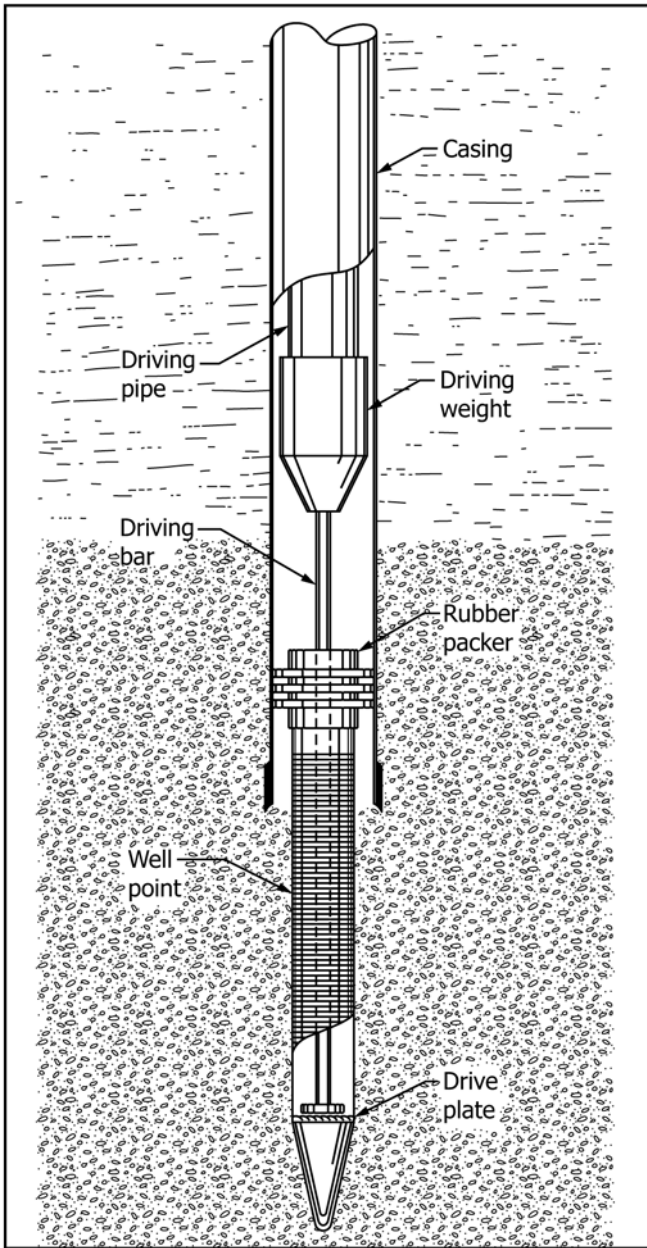

FIG. 1 Exposed-Screen Sampler—Well Point Driven Below the Base of a Borehole (11)

arrangement allows for grab sampling through the riser pipe without purging or development if there is no leakage at the screen seals and riser pipes. Fig. 3 shows a schematic of a direct-push water sampler with a protected screen and with the ability to work in the grab sampling mode or by allowing water to enter a sample chamber in the sampler body (5). Most simple sample chambers allow for flow through the chamber. When flow through chambered samplers is opened, it is possible that the groundwater from the test interval can fill into the rods above the chamber. In those cases, it may be advisable to add water of known chemistry into the rods prior to opening the screen. Some protected-screen samplers have sample chambers designed to reduce volume and pressure changes in the sample to avoid possible volatilization of volatile compounds (6,8,11). The need for pressurization is dependent on the requirements of the investigation program and should be evaluated by comparison studies in the field with simpler systems allowing the sample to equalize at atmospheric pressure. There are different approaches to pressurizing the sample chamber including use of inert gas pressure or using sealed systems. An example of a sealed vial-septum system is shown in Fig. 4 (6). In the sealed vial system, a septum is punctured with a hypodermic needle connected to a sealed vial. With this approach the vial will contain both a liquid and gas at aquifer pressure. The sealed vial-septum system has been used in an exposed-screen mode.

6.2.3 *Materials of Manufacture*—The choice of materials used in the construction of direct-push water sampling devices should be based on the knowledge of the geochemical environment to be sampled and how the materials may interact with the sample by means of physical, chemical, or biological processes. Due to the nature of insertion of these devices, the sampler body is typically comprised of steel, stainless steel, or metals of other alloys. The type of metal should be selected based on possible interaction effects with the fluid to be sampled. Well-screen materials can be selected from a variety of materials. Materials commonly used for well-screen elements include steel, stainless steel, rigid polyvinyl chloride (PVC), polytetrafluorethylene (PTFE), polyethylene (PE), polypropylene (PP), and brass. Sample chambers, pumps, and connector lines are also constructed with a variety of materials. Evaluating the possible interaction of materials that will be exposed to the water during the sampling event is important.

6.3 *Sampler Body*—The sampler body consists of a tip, and a barrel that consists of well screen, a protective sleeve if used, and a sampling chamber if used, with a connector assembly to attach to riser pipes or tubing. The sampler is normally constructed of steel to withstand insertion forces. The sampler barrel should be of constant outside diameter to ensure intimate contact with the soil to be tested. Protective sleeves shall be equipped with O-rings to prevent the ingress of water before the sampling event.

6.3.1 *Expendable Sampler Tips*—Some sampler tips are expendable and are left in the ground after the sampling event. The tip should be equipped with an O-ring seal to the sampler sleeve to prevent leakage into the riser pipe until the sampling depth is reached.

events which keep the port from clogging and purges the sampling line between sampling events.

6.2.1.1 Another form of an exposed-screen sampler has been incorporated into cone penetrometer bodies (10). The cone penetrometers have sample chambers with measurement devices such as temperature and conductivity. Some cone penetrometers have been equipped with pumps for drawing in water samples into sample chambers or to the surface. Samplers equipped with chambers and subjected to multiple sampling events may require purging between sampling events.

6.2.2 *Sealed-Screen Samplers*—Protected well screen and simple riser pipes for grab sampling are also deployed. An example is shown in Fig. 2 (15). This simple well screen

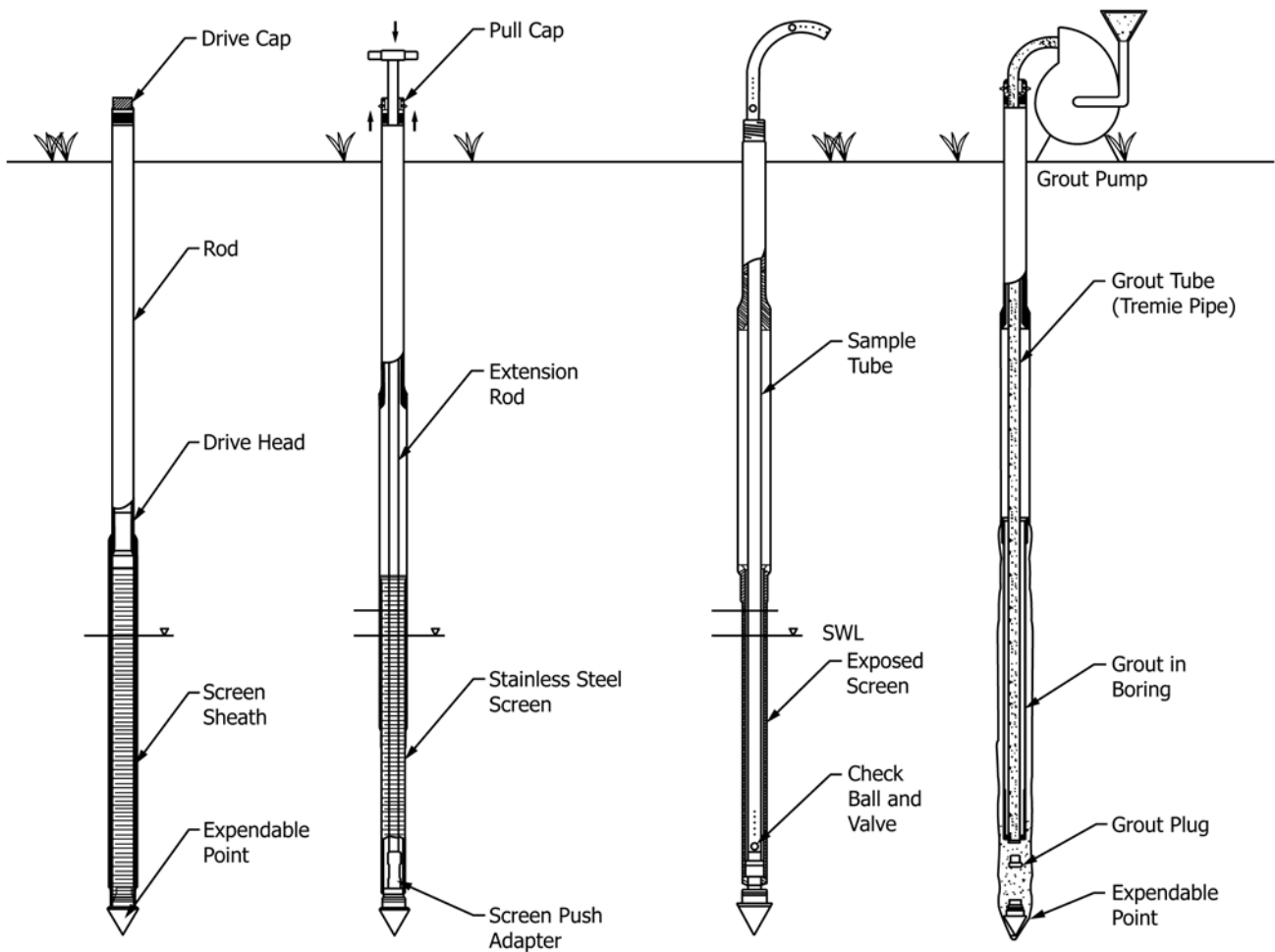

The assembled Sampler is driven to the desired sampling depth using standard rods.

Extension rods are used to hold the screen in position as the Casing Puller Assembly is used to retract the rods.

The tubing check valve can be used to sample groundwater.

Abandonment grouting can be conducted to meet ASTM requirements.

FIG. 2 Simple Protected Screen Sampler (9)

6.3.1.1 Sampler tips are designed so that upon pull back of the sampler body and riser pipe, the tip is disconnected from the sampler. The required diameter, and the ability to expend the tip successfully, depends on the soils to be penetrated. The tip diameter can be set equal to, or slightly less than, the sampler body. If there are problems with tip retraction, tips can be designed with a diameter of 1 to 3 mm ($1/8$ to $1/16$ in.) larger than the sampler body. The use of an enlarged diameter with a larger shoulder or tip may help in reaching greater depths because it acts as a friction reducer. An enlarged tip should not leave too large an annulus above the sampler body and riser pipes as to maintain a seal above the well screen and to prevent potential cross contamination.

6.3.1.2 Most sampler tips are made of steel to withstand pushing forces. With some samplers, after the sampling event, the tip may remain in the ground and the hole may be grouted. The user should consider if leaving the tips below the ground

will adversely affect surrounding groundwater chemistry depending on site conditions.

6.3.2 *Well Screen*—Many materials for well screens are available for direct-push samplers. The material of manufacture should be selected with consideration of chemical composition of the groundwater to be sampled and possible interactive effects (see 6.2.3). Some samplers use simple mill slotted steel, or PVC tube. Steel or brass screen formed into a cylinder can be used to cover inlets. Continuous-wrapped, wire-wound well points are also commonly used. The effective opening size of the well screen material should be selected based on the material to be sampled, the time required to sample, and soil sediment that can be tolerated in the water sample. Methods to size well-screen and filter-pack materials are given in Practice D5092. Clean sands and gravels can be sampled with a screen with larger openings without producing excessive sediment. Clayey and silty soils containing fines may

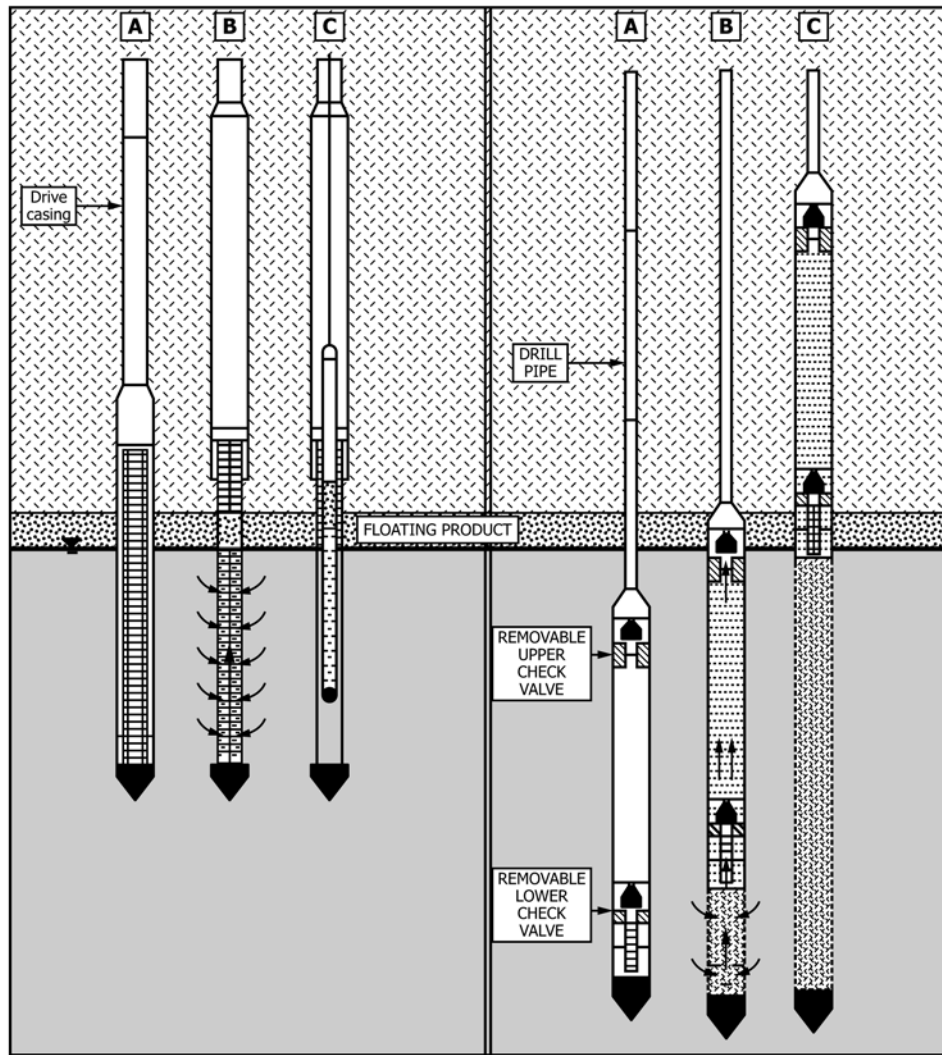

Legend: Grab Sampling

Legend: Water Sampling in Chamber

A Penetrometer closed while being driven into position.
 B Tool opened and 5 foot screen telescopes into position for collection of hydrocarbon or water sample at the very top of the aquifer.
 C Hydrocarbon sample being collected using bailer lowered through drive casing.

A Penetrometer closed while being driven into position.
 B Cone separated and tool open to collect sample.
 C Check valves closed as sample is retrieved within body of the tool.

FIG. 3 Protected Screen Sampler Capable of Working in Grab or Chamber Sampling Modes (1)

require finer openings. Typical openings of 10 to 60 μm are used. Finer openings will reduce sediment but may also slow ingress of fluid.

6.3.3 Some sampler inlets are not protected by well screen or slotting. The simplest form of sampler can be an open riser pipe with an expendable tip. The use of unprotected inlets has sometimes been useful to sample groundwater at soil/bedrock interface. If unprotected inlets are used, one must consider the amount of soil sediment that can be tolerated in the sample.

6.4 *Push Rod, Single Tube and Double Tube Systems and Riser Pipes*—Also commonly referred to as “push rods” or “extension rods,” drive tubes are normally constructed of steel to withstand pushing and impact forces. Most double tube systems use an outer casing and inner drive rods. The inner

drive rods are removed when ready for sampling (Fig. 5). Double-tube systems are advantageous if multiple sampling events are required in a single push. The outer casing of a double tube system prevents cross contamination from different aquifers. Some systems may use a double-tube system with a small-diameter PVC riser pushed by the steel tube (Fig. 6) (12). Other temporary systems may use a flexible tubing system connected to the well point (Fig. 7) (12). Most double tube systems have larger outside diameter and required more driving power. Single rod systems (Fig. 2) sometime have a larger diameter sampling body in front of smaller diameter drive rods and can cause concern if the sampler has to be driven through multiple aquifers. The single rod system is generally used for one time sampling events in the same hole.

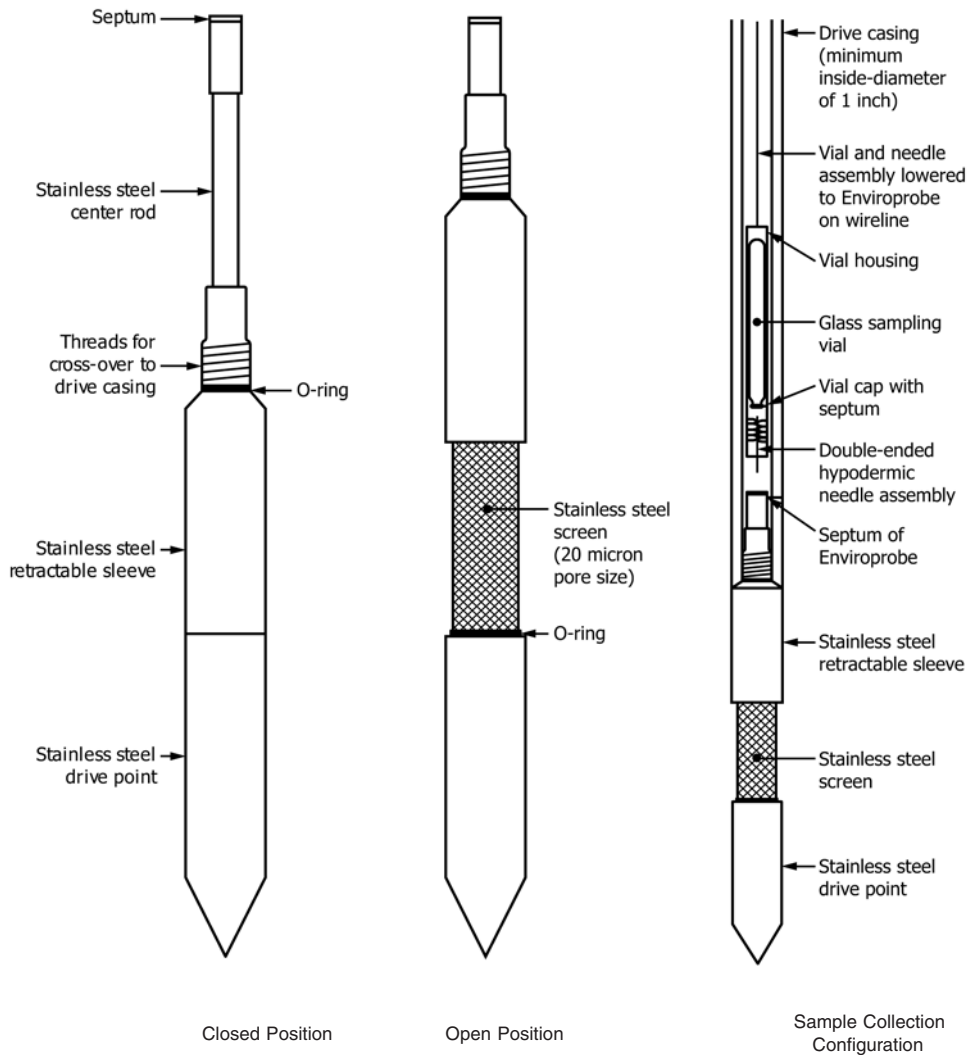

FIG. 4 Protected Screen Sampler with Sealed Vial System (4)

The maximum rod diameter that can be used depends on the material to be penetrated and the driving system. Increased rod diameter causes increase in the required driving force required to penetrate a sufficient distance. Most surface direct-push riser pipes are less than 50 mm (2 in.) in diameter.

6.4.1 Cone penetrometer rods as specified in Test Method D5778 are sometimes used in sampling systems deployed with cone penetrometer equipment. Larger diameter rods, typically 45 mm (1.75 in.), are sometimes used with cone penetrometer equipment.

6.4.2 Standard drilling rods used for rotary drilling are normally used when sampling is done at the base of drill holes. Many drill rods are available (see Guide D6286).

6.4.3 For direct-push sampling systems that depend on the riser pipe for sampling within the riser, ensuring that joints are watertight will be necessary such that water enters through the well screen interval to be sampled. Rods should be wrench-tightened, and PTFE tape can be used on the threads to stop leakage. The quality checks discussed in Section 8 can be performed to evaluate possible leakage. Sometimes it may be necessary to equip rod joint shoulders with O-rings to prevent

leakage. Cone penetrometer rods with precision tapered threads are normally watertight during short sampling events lasting up to 1 h if they are not damaged.

6.4.4 *Friction Reducers*—Friction reducers that have enlarged outside diameters of the riser pipe are sometimes employed to reduce thrust capacity needed to advance the well point or sampler. If friction reducers are used, they must be a sufficient distance above the sampling location to ensure that fluids from overlying layers cannot enter the sampling zone. If cross-contamination is possible, use of friction reducers should be avoided. In some cases the use of friction reducers can help in forming an annular seal. Donut-type reducers ream the hole smoothly. Lug-type reducers rip and remold the soil and may provide a better annular seal. The type and location of friction reducers should be documented in the project report.

6.4.5 *Mud Injection*—Some direct-push systems inject bentonite drill fluid along the drill rods to reduce friction. These systems normally inject the fluid behind friction reducers. These systems may provide better sealing above the sampler for the sampling process but are also more difficult to operate.

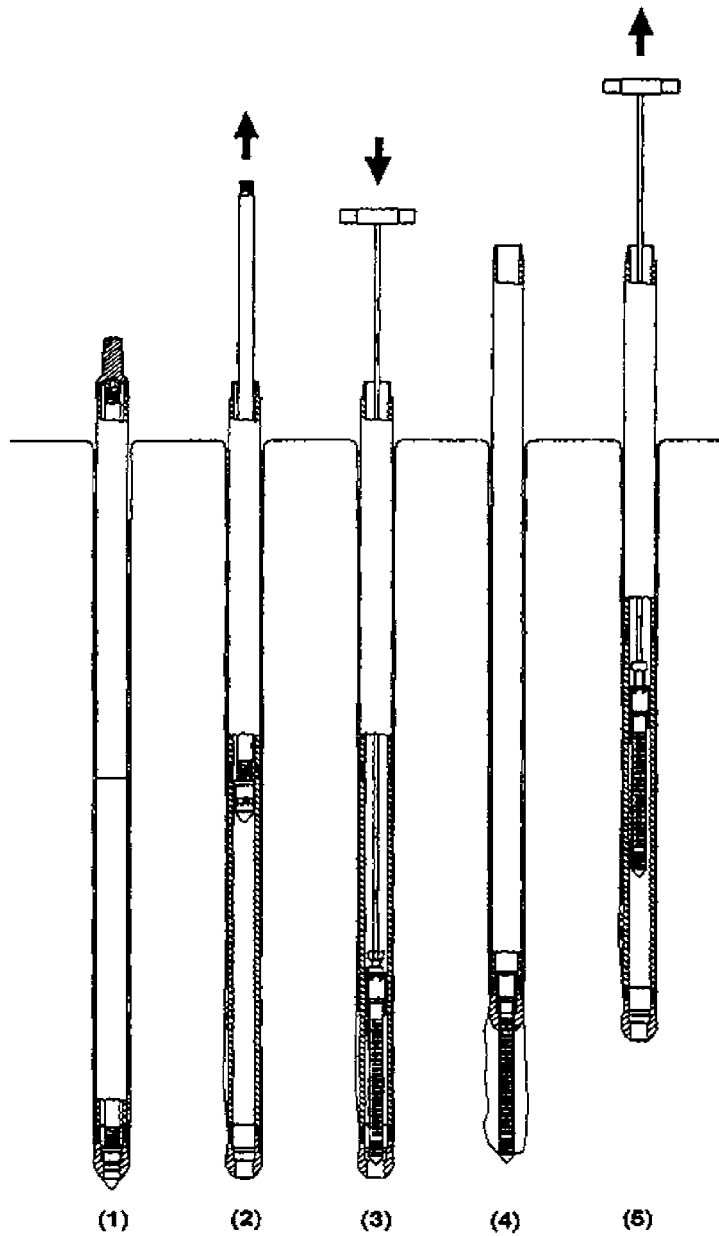

- (1) Advance outer casing to bottom of screen interval.
- (2) Remove inner rod string leaving open outer casing.
- (3) Lower screen to bottom of casing and hold in place with extension rods.
- (4) Retract casing to expose screen to formation, remove extension rods.
- (5) Retrieve screen after development, sampling, and fluid testing.

FIG. 5 Double Tube Sealed Screen Sampler

6.5 *Sampling Devices*—Consult Guide [D6634](#) for selection of sampling devices. Due to the small diameter of most direct-push equipment, pump selection is limited. Bladder pumps, gas-displacement pumps, peristaltic pumps, and inertial lift (tubing check valve) pumps may all be used for sampling.

6.6 *Sample Containers*—Sample containers for sampling groundwater are addressed in Guide [D6911](#).

6.7 *Driving or Pushing Equipment*—Soil probing (percussion driving) systems, penetrometer systems, and rotary drilling equipment are used for inserting direct-push water sampling devices. The equipment should be capable of applying sufficient mechanical force or have sufficient reaction weight, or both, to advance the sampler or screen to a sufficient depth to ensure an effective seal above the area to be sampled. The advancement system must also have sufficient retraction force

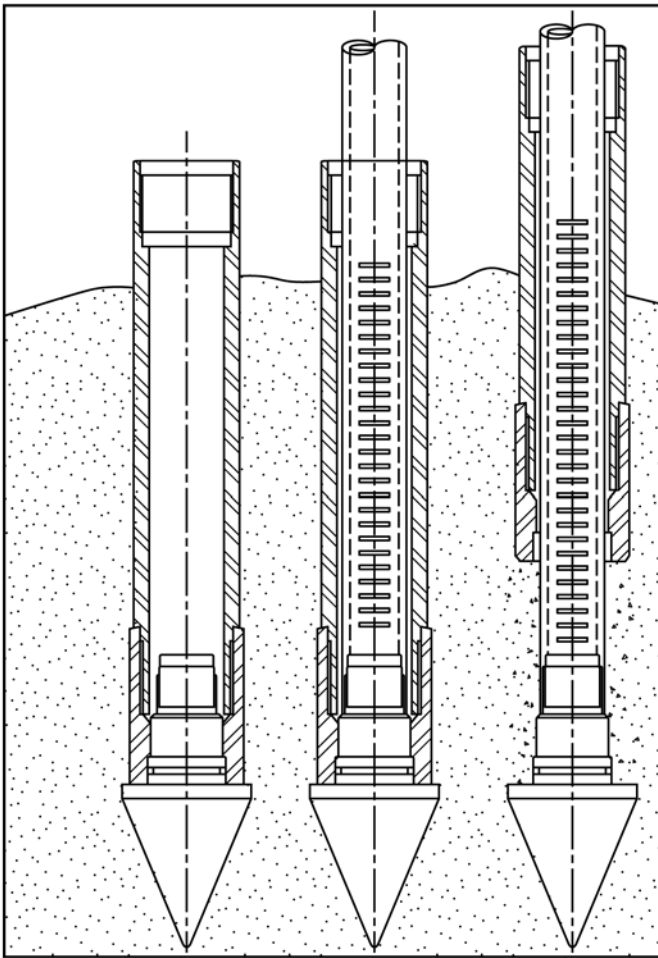

FIG. 6 Double-Tube Temporary Well Point System (12)

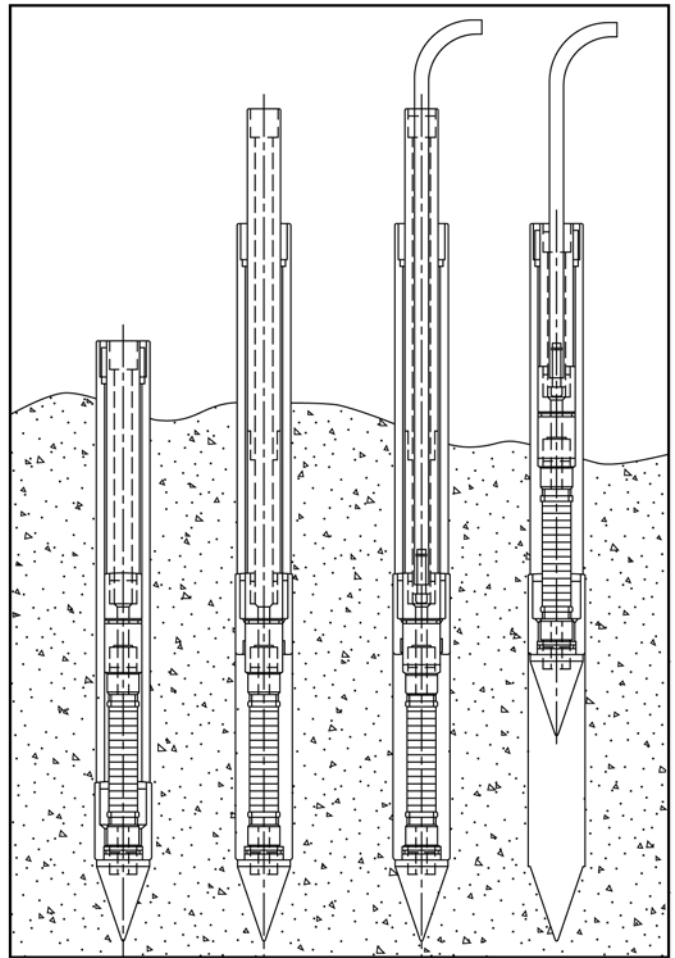

FIG. 7 Protected Screen Sampler with Sample Tubing (12)

to remove the rods, which is often a more difficult task than advancing the rods. Simple advancement systems include hand-held rotary-impact hammers with mechanical-extraction jacks. Many systems use hydraulic- or vibratory-impact hammers operating at high frequency to drive rods into the sampling interval. Reaction force can be reduced if impact hammers are employed. Multipurpose driving systems such as those commonly deployed for soil gas sampling (Guide D5314) are frequently used in shallow explorations. Some vibratory drilling systems can provide vibration to the rods and easily penetrate cohesionless soils. On soft ground sites, cone penetrometer systems use hydraulic rams to push the sampler and riser pipe into the ground. Conventional rotary drilling rigs can use either hydraulic pull-down capability or hammers to drive the sampler to the required depth. Rotary drilling rigs are often used with the incremental drilling and sampling method. A140-lb SPT hammer (Test Method D1586) is available on most rotary drilling rigs and can be used to advance the sampler. Use of impact or vibration may allow for penetration of harder soils. If a significant length of rods whip during driving, they should be restrained to prevent damaging of the annular seal at the base of a borehole from lateral movement.

7. Conditioning

7.1 *Decontamination*—Sampling equipment that contacts groundwater to be sampled before and after the sampling event may require decontamination. Decontamination should be performed following the procedures outlined in Practices D5088 and the site-sampling plan. The sampler body normally requires complete decontamination before sampling. Well-screen components are sometimes expendable. Newly manufactured screens and sampler components may contain residues from manufacture and should be cleaned before the sampling event. Riser pipes should be decontaminated if sampling will be performed within the tube. In many cases it's advantageous to have several samplers on hand so one can be cleaned while the other is being used.

7.2 *Purging*—For exposed-screen sampling devices and sampling systems open to overlying groundwater, purging may be required before the sampling event. With both protected- and exposed-screen samplers, purging may be required if groundwater from overlying sources infiltrates into the riser pipes into the sampling area. Purging should consist of removal of overlying groundwater from the sampling system prior to the sampling event. Purging requirements are outlined in Guides D6452 and D6771.

8. Procedure

8.1 Two procedures are outlined depending on whether the sampling device is pushed directly from the surface or whether drilling is used to advance an open hole close to the sampling interval. In either event, the sampling screen should be advanced into undisturbed soil a sufficient distance to ensure that the sampling depth cannot be exposed to overlying groundwater, if present. Consult Guide [D5903](#) prior to performing a groundwater sampling event.

8.1.1 *Incremental Drilling and Sampling*—In this method, advance a drill hole close to the sampling interval using drilling methods listed in [2.2](#). Of the drilling methods listed, the most commonly employed is rotary hollow-stem auger drilling because fluids are not introduced during the drilling process. If a rotary drilling method using drilling fluid or air is employed, the impact of the fluid or air to the sample quality and quality of the surrounding aquifer should be considered. If caving or sloughing occurs the use of protective casings may be required.

8.1.1.1 Stabilize the drill rig and erect the drill rig mast. Establish and document a datum for measuring hole depth. This datum may consist of a stake driven into a stable ground surface, the top of the surface casing, or the drilling deck. If the hole is to be later surveyed for elevation, record and report the elevation difference between the datum and the ground surface. Proceed with drilling until a depth is reached above the target sampling interval. Check and document the depth of the borehole and condition of the base of the hole. Establish the depth and condition of the base of the boring by resting the sampler at the base of the boring and checking depth to the sampler tip. If casing is used and heave occurs into the casing, remove this material and advance the hole deeper. Heave of soil into the casing may make it impossible to drive the water sampler without it carrying the casing along with the well point or sampler. If excessive heave, caving, or sloughing of soil occurs, consider using an alternative drilling method capable of maintaining stable soil conditions.

8.1.2 If the sampling event is to occur at the groundwater table and equipment depends on a dry-hole condition, that is, an exposed screen sampler with no purging requirements, test the drill hole to confirm that groundwater has not entered the hole. Water levels can be determined using Test Method [D4750](#).

8.1.3 Attach the well point or sampler to riser pipes and lower into the borehole. Carefully record the assembly length as rod sections are added to the assembly. Centralizers may be used to maintain verticality of the assembly and to reduce rod whip. Rest the assembly on the base of the borehole. Determine and record the depth to the tip of the assembly.

8.1.4 Either push or drive the well point or sampler a sufficient distance below the base of the boring. This distance should be at least 1 m (3 ft), or the minimum to ensure an effective seal. For protected-screen samplers where a protective screen is exposed by pulling back the riser pipe, the withdrawal action may shear or crack soil, allowing connection to the base of the borehole. In these cases, adjust the insertion and retraction lengths according to soil conditions. In general, the sampler should be inserted at least three times the effective screen length from retraction. To check the seal in fluid filled

holes, tracers can be introduced into the fluid in the base of the borehole. Document the final depth of insertion to the tip of the sampler and midpoint of the well screen. If the sampler is driven with hammer blows, accomplish the penetration without excessive vibrations that could reduce the effective seal of the riser pipe above the well screen. Normally, if smooth penetration is accomplished with each hammer blow, the seal should be intact.

8.1.4.1 The process of jetting well points is not preferred because of the addition of water, disturbance to the sampling zone, and lack of an effective seal above the screen. These installations are usually intended for permanent installations with the drill hole completed as a monitoring well. If jetting is used, document the approximate volume and chemical quality of water.

8.1.5 *Sampling*—The sampling process depends on the type of the sampling equipment used, that is, exposed- or protected-screen samplers.

8.1.5.1 *Sampling of Exposed-Screen Samplers*—Exposed-screen samplers can be sampled after fluids have been purged from the screen and riser pipes. Purge these systems in accordance with Guides [D4448](#), [D6452](#), and [D6771](#).

8.1.5.2 *Sampling of Protected-Screen Samplers*—Test protected-screen samplers that are open to the surface through the riser for grab sampling for system leakage before exposing the screen for sampling. Before screen exposure, test the riser for presence of water that may have leaked through joints and connections using Test Method [D4750](#). If water is present from unknown sources, this should be noted and either purging or abandoning of the test should be considered. After quality checks for leakage, the riser pipes may be pulled or twisted to expose the well screen to the aquifer.

8.1.5.3 Several methods for sampling water are available. If the sampling device uses head pressure available in the aquifer, sufficient time should be allowed for water to fill the sampling chamber or riser pipes. Some systems allow for connection of a sealed sampling chamber, or tubing, to a port in the sampler body after the screen is opened, allowing direct connections to the screened sampling area. By using these systems, one may avoid the necessity to check inside the riser pipes for leakage water. Use of sampling pumps to draw in the sample may be allowed, but consideration should be given to the changes in ambient pressures and temperatures that may change chemical compositions. With an open tube well screen using grab or pump sampling in low permeability soils, a vacuum is sometimes applied to the top of the riser pipe to accelerate groundwater inflow. The use of a vacuum and its effect on chemical composition should be considered and evaluated if site requirements dictate.

8.1.5.4 After a sufficient volume of the sample is obtained, place the samples in suitable containers for analysis and preserve them if required (Guides [D6517](#) and [D6911](#)). The volume of a sample to be obtained depends on the chemical composition of groundwater, testing protocols, and the data-quality objectives. Depending on the screen or porous filter used, samples may contain turbidity and/or sediment and may require filtering before placement of samples in containers.

Certain testing procedures or regulations may require filtration of water samples. Consult Guide [D6564](#) for filtering ground-water samples.

8.1.6 After sampling, either retrieve the sampler or leave it in place for permanent installation in accordance with Practice [D5092](#) and Guide [D6724](#). Some retrievable samplers leave a tip or a well screen element, or both, below the bottom of the boring. If repeated sampling events are to be performed in the same drill hole, drilling it through these pieces if present will be necessary. Depending on the drilling method, a pilot bit should be reinserted in the drill string and drilling continued to a depth exceeding the depth of the previous sampling event. Tips or screens from the previous sampling event, will be drilled through or moved to the side of the drill hole by drilling action before the next sampling event. Sometimes the presence of a tip or element, or both, can be detected by drilling action. If drilling action detects these pieces, note the location. Drilling continues to the next depth of concern and sampling may be repeated. The depth of the extended drill hole should equal or exceed the depth to the sampling tip of the previous interval.

8.1.7 After the drilling is completed, the drill hole should be completed following guidelines in drilling methods (Guide [D6286](#)) or those given in Section 9.

8.2 *Direct-Push from the Surface*—Well points and samplers may be advanced directly from the surface with multipurpose percussion driving systems, hand-held rotary percussion drills, cone penetrometer systems, or any other systems capable of supplying sufficient force to reach the depths of concern.

8.2.1 Stabilize and level the rig for testing. For some tire-mounted equipment, the rig can be raised off the ground and leveled with hydraulic rams to lift the rig from the tires to avoid shifting during difficult driving conditions. Establish and document a datum for measuring hole depth. If the hole is to be later surveyed for elevation, record and report the height of the datum to the ground surface.

8.2.2 The sampler body is connected to riser pipes along with any subassemblies such as friction reducers. Prior to driving, measure the length of the sampler assembly and riser pipes to determine the depth of sampling. Some temporary well systems drive a double tube or cased system, where riser pipe and casing are added as it is advanced. This allows for easy annulus grouting as the casing is retracted. The rods are then pushed using smooth quasi static push or impacts, or both. Additional riser pipes are added as pushing progresses. As driving progresses, operators should carefully record the rods added to ensure that sampling occurs at the correct depth.

8.2.3 *Sampling of Exposed-Screen Samplers*—Use the same procedures in accordance with [8.1.5.1](#).

8.2.4 *Sampling of Protected-Screen Samplers*—Use the procedure in accordance with [8.1.5.2](#) with the addition that the riser pipes should be periodically checked for leakage using Test Method [D4750](#).

8.2.5 After sufficient volume of a sample is procured, place the samples in suitable containers and preserve them if required (Guides [D6517](#) and [D6911](#)). The volume of the sample to obtained depends on the chemical composition of groundwater, testing protocols, and the data-quality objectives. Depending on the screen used, samples may contain turbidity and/or

sediment and may require filtering before placement of samples in containers (Guide [D6564](#)).

8.3 After sampling, the sampler is either retrieved or left in place for permanent installation (Section 9). Some retrievable samplers leave a tip or a well-screen element, or both, at the bottom of the sounding. If repeated sampling events are to be done in the same hole, they must be done with samplers pushed to greater depths.

8.4 After the testing is finished, complete the borehole following the guidelines in Section 9.

9. Completion and Abandonment

9.1 *Permanent or Temporary Well Installations*—Wells inserted by either drilling methods or direct-push from the surface may be left in the ground as permanent or temporary installations. Refer to Guide [D6724](#) for direct-push well installation. For wells inserted in drill holes, the drill hole will require completion with sealing materials to ensure a seal between the hole wall and riser pipes. Sealing procedures are given in Practice [D5092](#).

NOTE 2—For wells installed by direct push from the surface, the need for sealing depends on the size of the annulus, groundwater quality, and the ability for cross-contaminating or accelerating contamination movements among aquifer(s). Temporary well points installed into the top of the first groundwater layer may only require surface sealing. If the annulus is very small, soil cave and squeeze may reduce effective vertical hydraulic conductivity. If the well riser intersects perched aquifers, cross-communication of aquifers may be possible if too large an annulus is left open. Communication can be evaluated by performing tracer tests, if necessary. Friction reducers used on cone penetrometer equipments may only increase hole diameters by 6 to 13 mm ($\frac{1}{4}$ to $\frac{1}{2}$ in.) of that of the steel pipes for pushing.

9.2 *Other Completion Methods*—Performing special completions with protective casings or other sealing methods may be necessary depending on the investigation requirements. For holes using rotary drilling methods and incremental sampling, the hole could be completed as a monitoring well (Practice [D5092](#)) or with grouted casings for other testing such as geophysical tests. Several methods are available for grouting of casings. The most desirable method is injection grouting, where injection is done at the base of the boring is most desirable and grouts are pumped up the annulus until they reach the surface showing a continuous seal.

9.3 *Hole Abandonment*—For test holes where there are no installations or other completion methods, the hole should be abandoned following program requirements. The need for and the method of sealing for abandonment depends on state and local regulations, site conditions, groundwater quality, and the ability for cross-contaminating or accelerating contamination movements among aquifer(s).

9.3.1 Large-diameter drill holes from rotary drill operation which intersect the groundwater often require sealing. State, federal, and local regulations may dictate abandonment requirements for boreholes intersecting the water table.

9.3.1.1 The need for sealing of holes is also dependent on geohydrologic conditions. If the hole intersects the top of the first groundwater table, complete sealing may not be required. Under a homogeneous single aquifer system, where there are no perched water table or artesian conditions, there will be

little hydraulic gradient to move potential contaminants at differing elevations. The worst case for possible cross-communication of aquifers occurs under perched or confined groundwater conditions.

9.3.1.2 In most cases, direct-push holes intersecting groundwater tables will require complete sealing. In cases where the hole is to be backfilled completely, the condition of the hole should be evaluated and documented. Any zones of caving or blocking which preclude complete sealing should be documented. Displacement grouting may displace groundwater from the hole to the surface. If this water is considered contaminated then provisions must be made to collect these fluids at the surface. A minimum requirement for sealing should be that the surface of the hole is sealed to prevent hazards to those at the surface and to eliminate direct movement of surface contaminants to the water table through the hole.

9.3.2 *Completion of Drill Holes*—Completion of boreholes using drilling methods are addressed in Guides D5781, D5782, D5783, D5784, D5875, D5876, and also see 2.2.

9.3.3 *Completion of Surface Direct-Push Holes*—Several methods have been used successfully for sealing or grouting of surface direct-push holes (16). The method of grouting depends on the types of equipment deployed and the subsurface conditions encountered.

9.3.3.1 *Retraction Grouting*—One method of grouting is retraction grouting directly through the sampler tip or friction reducer as the sampler is withdrawn after the sampling event. Tip retraction grouting is normally performed through small diameter tubes and a knockoff tip. Tip retraction grouting is the least frequently used due to difficulty in pumping grout mixtures without significant head loss through the tubing. Cement grouts for tip retraction grouting may require higher water content or additives to reduce viscosity.

(1) Retraction grouting is sometimes performed through grouting points above the sampler tip. This is normally accomplished using an enlarged diameter grouting port above the sampler as shown in Fig. 8.

9.3.3.2 *Reentry Grouting*—Reentry grouting may have an advantage of freeing pushing equipments for production while grouting operations follow. Reentry grouting allows temporary connection of aquifers between the removal and reinsertion process but is normally acceptable if grouting follows promptly minimizing exposure. The selection of retraction or reentry grouting is an economic decision and it depends on site conditions and depth of soundings.

(1) In reentry grouting, Figs. 9 and 10, the test string is completely withdrawn from the hole and a secondary grouting tube or tubing is reinserted to the complete depth of the hole. If the hole remains open after retraction of the test string, inserting flexible tubing or small-diameter PVC into the hole by hand directly after testing may be possible. In this case, reinserting the grout line is desirable close to the original depth of the hole. In some cases, depending on project needs, locations of water bearing strata, and soil stratigraphy, it may be acceptable if the grout line does not reach the bottom of the hole.

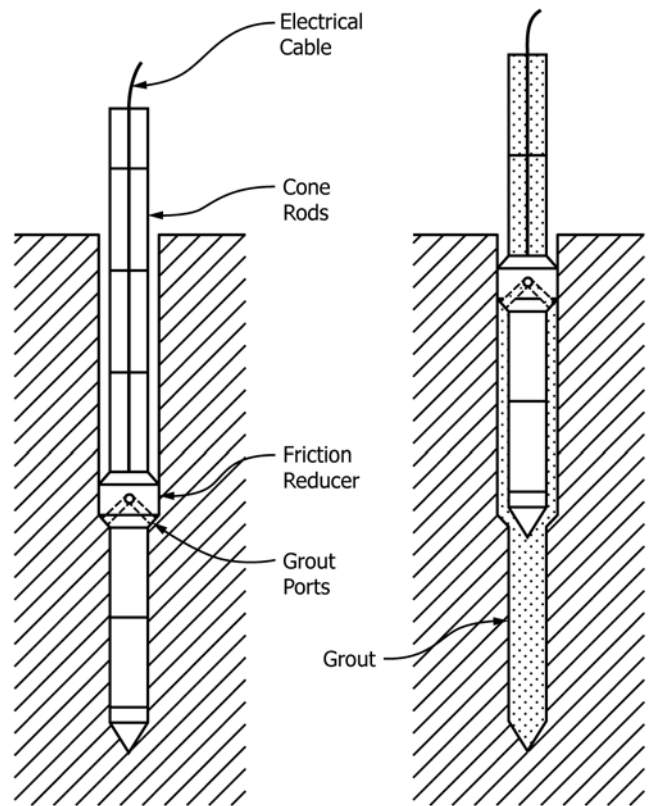

(a) Installation (b) Grouting
FIG. 8 Grouting Through Ports in Friction Reducers (15)

(2) Usually, with squeezing clays or caving sands, reaction equipment may be required to push rigid tubing of steel or plastic with a sacrificial or grouting tip to the complete depth of the hole (Figs. 9 and 10). The reentry string should follow the original hole alignment because it is the path of least resistance. If deviation is suspected, it should be reported. If a knockoff tip is to be retracted in high hydraulic conductivity sands it may be necessary to add grout into rods prior to tip retraction to avoid water filling the rods. Grout is then pumped through the hole until it rises to the surface, or tremie grouting is performed by maintaining a grout column in the rods as they are removed. Grouting is continued to maintain a full hole as tubing is withdrawn.

9.3.3.3 *Direct-push water sampling holes* can be grouted with either cement or bentonite grouts. The grout consistency may have to be wetter than standard mixes used for sealing boreholes (Practice D5092). There has been no research to confirm the best proportions. A typical mixture is 1 sack of Portland cement to 19 to 22 L (5 to 8 gal) of water. Bentonite is added in a small percentage, 2 to 5 %, to reduce shrinkage. Typical bentonite-based mixtures consist of 22.7 kg of dry powered bentonite to 50 to 200 L (24 to 55 gal) of water. It is difficult to mix dry high-yield bentonite without good circulation equipment and time to allow for mixing and hydration. Pre-hydrated bentonite is easier to mix. Some bentonites contain additives that may not be acceptable for grouting use and the user should check with regulators to ensure sealing products are acceptable.

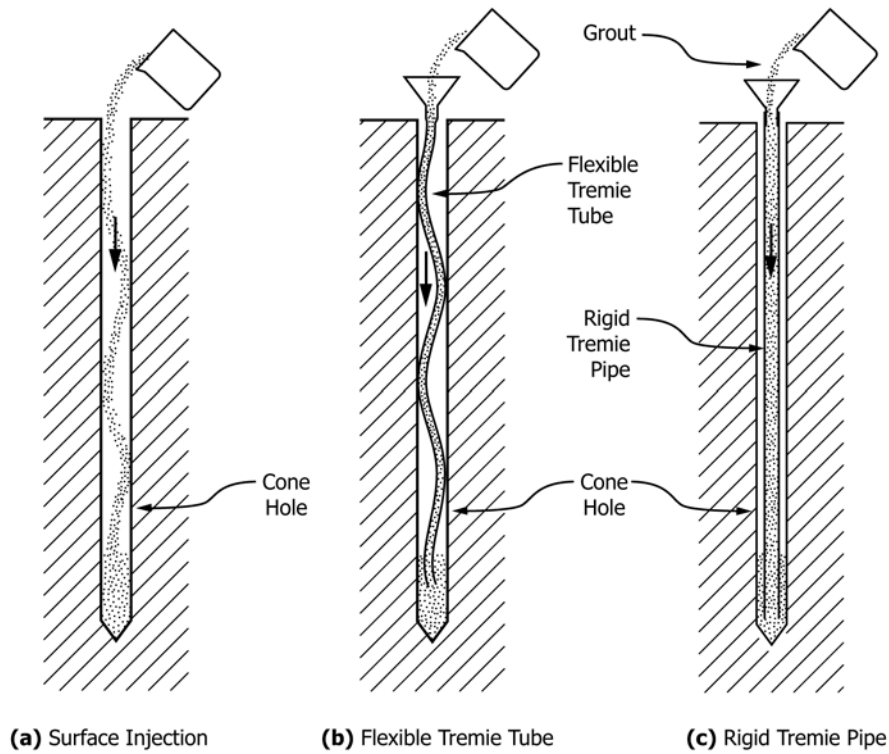

FIG. 9 Rigid Pipe with Internal Flexible Tremie Tube (15)

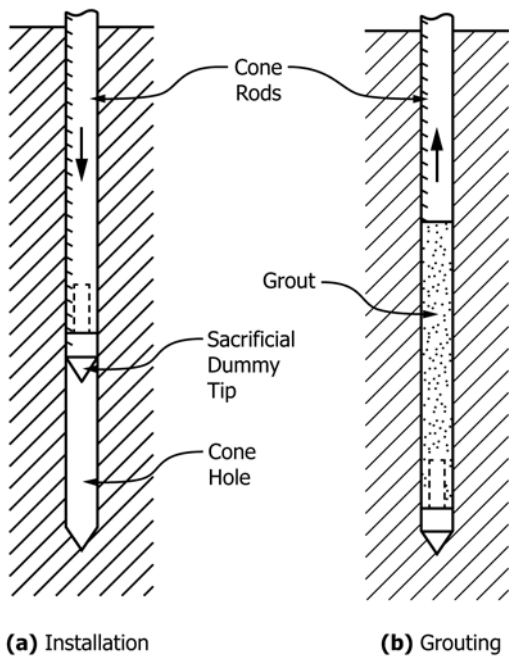

FIG. 10 Reentry with CPT Rods and Sacrificial Tip (15)

9.3.3.4 Record the volumes of grout injected and compare them with theoretical hole volumes. Often the grouting pressure at depth is unknown due to head losses through pipes, grout tubing, and connections. Pressure grouting equipments should at a minimum include a pressure gage at the surface. To avoid excessive hydraulic fracturing of the units, downhole pressures should be restricted to 1/2 psi per foot of hole depth.

Record any unusual changes in grouting pressures that may suggest the presence of obstructions, caved zones, or occurrence of fracturing.

9.3.3.5 *Dry Granular Bentonite*—The simplest method of sealing a direct-push hole in stable materials is to place dry materials by pouring or placing directly into the open hole after testing. This method is normally only acceptable in stable clay soils above the water table where the hole remains open after testing. This method is not acceptable if there are zones of hole caving or squeezing or there is appreciable presence of groundwater in the hole. The holes can be probed with small-diameter rods to evaluate these conditions. Small diameter granular bentonite is normally used in this application.

10. Field Report and Project Control

10.1 Report information recommended in Guide D5434 and Test Method D6034 and identified as necessary and pertinent to the needs of the exploration program. Information is normally required for the project, exploration type and execution, drilling equipment and methods, subsurface conditions encountered, groundwater conditions, sampling events, and installations. Some of the data collected during these investigations may be reported as data elements for describing groundwater sites (Practice D5254, and Guide D5474).

10.2 Other information besides that mentioned in Guide D5434 and Test Method D6034 should be considered if deemed appropriate and necessary to the needs of the exploration program. Additional information should be considered as follows:

10.2.1 *Drilling Methods*—If rotary drilling methods are used for predrilling holes, report information particular to the

drilling methods as outlined in Guides D5781, D5782, D5783, D5784, D5875, D5876, and also see 2.2.

10.2.2 *Percussion Driving and Penetrometer Equipment*—For equipment used for surface direct-push, report the equipment type, make, model, and manufacturers. Report conditions during push of the sampler such as the occurrence of hard layers. Report datums established for monitoring depth of penetration. For combined cone penetrometers and water-sampling devices, report cone-penetration information in accordance with Test Methods D3441 and D5778.

10.3 Sampling:

10.3.1 *Equipment*—Report the types of sampling equipment used including materials of manufacture of the components. Provide dimensions of the equipment including outside diameter, screen length and diameter, and friction reducers. Report methods for cleaning of the equipment before and after sampling. Note materials left in the hole or discarded between sampling events. Report any purging or development actions taken before the sampling event.

10.3.2 When water sampling is performed at the base of the borehole, report the condition of the base of the hole before sampling, and report any slough or cuttings present in the recovered sample.

10.3.3 During insertion of the sampler or well point, note any difficulties in advancing the point and retraction of a protective sleeve. Report the retraction distance for protected-screen samplers. If the sampler cannot be advanced more than the minimum required distance of the sampler given in 8.1.4, report the distance driven. Note and record sampling depths

including depths to the tip and midpoint of the well screen. Note any unusual occurrence during sampling such as fluid exposure, or evidence of cross-contamination contained in the samples recovered. Note and record the volume of the sample taken and other sample handling and preservation methods taken.

10.3.4 Report any measurements of water samples routinely performed in the field. These measurements may include temperature, PH, and conductivity. Report methods of testing, calibrations, and equipment used.

10.4 *Completion and Installations*—A description of completion materials and methods of placement, approximate volumes placed, intervals of placement, methods of confirming placement, and areas of difficulty or unusual occurrences.

11. Precision and Bias

11.1 The precision and bias of this method have not been established. Due to variability of subsurface conditions, comparative studies of differing approaches to direct-push sampling have not been statistically significant, because site spatial variability exceeded differences between methods (2). Comparisons between water samples obtained from direct-push samples and standard-monitoring wells have been favorable (17). Additional studies are needed and are actively pursued by Subcommittee D18.21.

12. Keywords

12.1 direct-push; groundwater; groundwater sampling; site characterization; well point

REFERENCES

- (1) U.S. EPA, Expedited Site Assessment Tools for Underground Storage Tank Sites, A Guide for Regulators, EPA 510 B 97 001, U.S. EPA Office of Underground Storage Tanks, Washington DC, 1997.
- (2) Applegate, J. L., and Fitton, D. M., "Rapid Site Assessment Applied to the Florida Department of Environmental Protection's Drycleaning Solvent Cleanup Program," *HazWaste World Superfund XVIII Conference Proceedings*, December, 1997, Washington D.C., pp. 695–703.
- (3) Cordry, K., "Ground Water Sampling Without Wells," *Proceedings of the National Water Well Association, Sixth National Symposium on Aquifer Restoration and Ground Water Monitoring*, May 19–22, 1986, Columbus, OH, pp. 262–271.
- (4) Zemo, D., et al, "Cone Penetrometer Testing and Discrete-Depth Groundwater Sampling Techniques: A Cost Effective Method of Site Characterization in a Multiple Aquifer Setting," *Proceedings of the National Ground Water Association, Outdoor Action Conference*, May 11–13, 1992, Las Vegas, NV, pp. 299–313.
- (5) Smolley, M., and Kappemyer, J., "Cone Penetrometer Tests and Hydropunch™ Sampling—An Alternative to Monitoring Wells for Plume Detection," *Proceedings of the Hazmacon 1989 Conference*, April 18–20, 1989, Santa Clara, CA, pp. 71–80.
- (6) Berzins, N. A., "Use of the Cone Penetration Test and BAT Groundwater Monitoring System to Assess Deficiencies in Monitoring Well Data," *Proceedings of the National Ground Water Association Outdoor Action Conference*, 1992, pp. 327–341.
- (7) Strutynsky, A., and Bergen, C., "Use of Piezometric Cone Penetration Testing and Penetrometer Groundwater Sampling for Volatile Organic Contaminant Plume Detection," *Proceedings of the National Water Well Association Petroleum Hydrocarbons Conference*, Oct. 31–Nov. 2, 1990, Houston, TX, pp. 71–84.
- (8) Klopp, R. A., Petsonk, A. M., and Torstensson, "In-Situ Penetration Testing for Delineation of Ground Water Contaminant Plumes," *Proceedings of the Third National Outdoor Action Conference on Aquifer Restoration, Ground Water Monitoring and Geophysical Methods*, May 22–25, 1989, National Ground Water Association, Dublin, OH, pp. 329–343.
- (9) Church, P. E., and Gvanato, G. E., "Bias in Ground-Water Data Caused by Well Bore Flow in Long Screen Wells," *Ground Water*, March–April 1996, Ground Water Publishing, Columbus, OH, 1996, pp. 262–273.
- (10) Woeller, D. J., Weemees, I., Kokan, M., Jolly, G., and Robertson, P. K., "Penetration Testing for Groundwater Contaminants," *ASCE Geotechnical Engineering Congress, Special Technical Publication*, June 1991.
- (11) Eckard, T. L., Millison, D., Muller, J., Vander Velde, E., and Bowallius, R. U., "Vertical Ground Water Monitoring Using the BAT Groundwater Monitoring System," *Proceedings of the Third National Outdoor Action Conference on Aquifer Restoration, Ground Water Monitoring and Geophysical Methods*, May 22–25, 1989, National Ground Water Association, Dublin, OH, pp. 313–327.
- (12) Driscoll, F. G., *Groundwater and Wells*, Johnson Filtration Systems Inc., St. Paul, MN, 55112, 1986.
- (13) Pitkin, S., Ingleton, R. A., and Cherry, J. A., "Use of a Drive Point Sampling Device for Detailed Characterization of a PCE Plume in a

- Sand Aquifer at a Dry Cleaning Facility,” *Proceedings, Eighth National Outdoor Action Conference and Exposition, National Ground Water Association*, Dublin, Ohio, 1994, pp. 395–412.
- (14) Pitkin, S. E., Cherry, J. A., Ingleton, R. A., and Broholm, M., “Field Demonstrations Using the Waterloo Ground Water Profiler,” *Ground Water Monitoring and Remediation*, Vol 19, No. 2, 1999, pp. 122–131.
- (15) *Geoprobe Screen Point Ground Water Sampler—Standard Operating Procedure, Technical Bulletin No. 94-440*, Geoprobe Systems, April 1994.
- (16) Lutennegger, A. J., and DeGroot, D. J., “Techniques for Sealing Cone Penetrometer Holes,” *Canadian Geotechnical Journal*, Vol 32, No. 5, pp. 880–891.
- (17) Zemo, D. A., Pierce, Y. G., Gallinatti, J. D., “Cone Penetrometer Testing and Discrete-Depth Ground Water Sampling Techniques: A Cost Effective Method of Site Characterization in a Multiple Aquifer Setting,” *Ground Water Monitoring Review*, Fall 1994, National Ground Water Association, Dublin, OH, pp. 176–182.
- (18) Campanella, R. G., Davies, M. P., Boyd, T. J., and Everard, J. L., “In-Situ Teating Methods for Groundwater Contamination Studies,” *Developments in Geotechnical Engineering*, Balasubramaniam et al (eds), Balkema, Rotterdam, pp. 371–379.
- (19) Schematic Drawings Courtesy of Diedrich Drilling Inc., LaPorte, IN.

ASTM International takes no position respecting the validity of any patent rights asserted in connection with any item mentioned in this standard. Users of this standard are expressly advised that determination of the validity of any such patent rights, and the risk of infringement of such rights, are entirely their own responsibility.

This standard is subject to revision at any time by the responsible technical committee and must be reviewed every five years and if not revised, either reapproved or withdrawn. Your comments are invited either for revision of this standard or for additional standards and should be addressed to ASTM International Headquarters. Your comments will receive careful consideration at a meeting of the responsible technical committee, which you may attend. If you feel that your comments have not received a fair hearing you should make your views known to the ASTM Committee on Standards, at the address shown below.

This standard is copyrighted by ASTM International, 100 Barr Harbor Drive, PO Box C700, West Conshohocken, PA 19428-2959, United States. Individual reprints (single or multiple copies) of this standard may be obtained by contacting ASTM at the above address or at 610-832-9585 (phone), 610-832-9555 (fax), or service@astm.org (e-mail); or through the ASTM website (www.astm.org). Permission rights to photocopy the standard may also be secured from the Copyright Clearance Center, 222 Rosewood Drive, Danvers, MA 01923, Tel: (978) 646-2600; <http://www.copyright.com/>