



Designation: D5967 – 17

Standard Test Method for Evaluation of Diesel Engine Oils in T-8 Diesel Engine¹

This standard is issued under the fixed designation D5967; the number immediately following the designation indicates the year of original adoption or, in the case of revision, the year of last revision. A number in parentheses indicates the year of last reappraisal. A superscript epsilon (ϵ) indicates an editorial change since the last revision or reappraisal.

1. Scope*

1.1 This test method covers an engine test procedure for evaluating diesel engine oils for performance characteristics, including viscosity increase and soot concentrations (loading).² This test method is commonly referred to as the Mack T-8.

1.2 This test method also provides the procedure for running an extended length T-8 test, which is commonly referred to as the T-8E and an abbreviated length test, which is commonly referred to as T-8A. The procedures for the T-8E and the T-8A are identical to the T-8 with the exception of the items specifically listed in [Annex A8](#) and [Annex A9](#) respectively. Additionally, the procedure modifications listed in [Annex A8](#) and [Annex A9](#) refer to the corresponding section of the T-8 procedure.

1.3 The values stated in SI units are to be regarded as standard. No other units of measurement are included in this standard.

1.3.1 *Exceptions*—Where there is no direct SI equivalent such as the units for screw threads, National Pipe Threads/diameters, tubing size, sole source equipment suppliers, and oil consumption in grams per kilowatt-hour.

1.4 *This standard does not purport to address all of the safety concerns, if any, associated with its use. It is the responsibility of the user of this standard to establish appropriate safety and health practices and determine the applicability of regulatory limitations prior to use.* See [Annex A6](#) for specific safety precautions.

1.5 A Table of Contents follows:

Scope	1
Referenced Documents	2
Terminology	3
Summary of Test Method	4

¹ This test method is under the jurisdiction of ASTM Committee D02 on Petroleum Products, Liquid Fuels, and Lubricants and is the direct responsibility of Subcommittee D02.B0.02 on Heavy Duty Engine Oils.

Current edition approved May 1, 2017. Published June 2017. Originally approved in 1996. Last previous edition approved in 2015 as D5967 – 15a. DOI: 10.1520/D5967-17.

² The ASTM Test Monitoring Center will update changes in this test method by means of Information Letters. This edition incorporates revisions contained in all information letters through 16-1. Information letters may be obtained from the ASTM Test Monitoring Center, 6555 Penn Avenue, Pittsburgh, PA 15206-4489, Attention: Administrator.

Significance and Use	5
Apparatus	6
General Description	6.1
The Test Engine	6.2
Mack Test Engine	6.2.1
Engine Cooling System	6.2.2
Engine Oil System	6.2.3
Auxiliary Oil System	6.2.4
Crankcase Aspiration	6.2.5
Blowby Meter	6.2.6
Air Supply and Filtration	6.2.7
Fuel Supply	6.2.8
Intake Manifold Temperature Control	6.2.9
Engine Fluids	7
Test Oil	7.1
Test Fuel	7.2
Engine Coolant	7.3
Cleaning Materials	7.4
Preparation of Apparatus at Rebuild	8
Cleaning of Parts	8.1
Valves, Seats, Guides, and Springs	8.2
Cylinder Liner, Piston, and Piston Ring Assembly	8.3
Injectors and Injection Pump	8.4
Assembly Instructions	8.5
Measurements	8.6
Laboratory and Engine Test Stand Calibration/Non-Reference Requirements	9
Calibration Frequency	9.1
Calibration Reference Oils	9.2
Test Numbering	9.3
New Laboratories and New Test Stands	9.4
Calibrated Laboratories and Test Stands	9.5
Calibration Test Acceptance	9.6
Failing Calibration Tests	9.7
Non-Reference Oil Test Requirements	9.8
Procedure	10
Pretest Procedure	10.1
Engine Start-Up	10.2
Engine Shutdown	10.3
Test Cycle	10.4
Oil Addition/Drain	10.5
Oil Samples	10.6
Oil Consumption Calculations	10.7
Fuel Samples	10.8
Periodic Measurements	10.9
Blowby	10.10
Centrifugal Oil Filter Mass Gain	10.11
Oil Filter ΔP Calculation	10.12
Post Test	10.13
Inspection of Fuel and Oil During Test	11
Oil Inspection	11.1
Fuel Inspections	11.2
Oil Consumption	11.3
Report	12
Reporting Test Results	12.1
Deviations from Test Operational Limits	12.2
Electronic Transmission of Test Results	12.3
Plots of Operational Data	12.4

*A Summary of Changes section appears at the end of this standard

Precision and Bias	13
Precision	13.1
Bias	13.2
Keywords	14
Annexes	
Report Forms	Annex A1
Sensor Locations	Annex A2
Kinematic Viscosity At 100°C For Test Method D5967 Samples	Annex A3
Enhanced Thermal Gravimetric Analysis (TGA) Procedure	Annex A4
Procurement of Test Materials	Annex A5
Safety Precautions	Annex A6
Data Dictionary	Annex A7
T-8E Extended Length Test Requirements	Annex A8
T-8A Abbreviated Length Test Requirements	Annex A9

1.6 *This international standard was developed in accordance with internationally recognized principles on standardization established in the Decision on Principles for the Development of International Standards, Guides and Recommendations issued by the World Trade Organization Technical Barriers to Trade (TBT) Committee.*

2. Referenced Documents

2.1 ASTM Standards:³

- [D86 Test Method for Distillation of Petroleum Products and Liquid Fuels at Atmospheric Pressure](#)
- [D93 Test Methods for Flash Point by Pensky-Martens Closed Cup Tester](#)
- [D97 Test Method for Pour Point of Petroleum Products](#)
- [D130 Test Method for Corrosiveness to Copper from Petroleum Products by Copper Strip Test](#)
- [D235 Specification for Mineral Spirits \(Petroleum Spirits\) \(Hydrocarbon Dry Cleaning Solvent\)](#)
- [D287 Test Method for API Gravity of Crude Petroleum and Petroleum Products \(Hydrometer Method\)](#)
- [D445 Test Method for Kinematic Viscosity of Transparent and Opaque Liquids \(and Calculation of Dynamic Viscosity\)](#)
- [D446 Specifications and Operating Instructions for Glass Capillary Kinematic Viscometers](#)
- [D482 Test Method for Ash from Petroleum Products](#)
- [D524 Test Method for Ramsbottom Carbon Residue of Petroleum Products](#)
- [D613 Test Method for Cetane Number of Diesel Fuel Oil](#)
- [D664 Test Method for Acid Number of Petroleum Products by Potentiometric Titration](#)
- [D976 Test Method for Calculated Cetane Index of Distillate Fuels](#)
- [D1319 Test Method for Hydrocarbon Types in Liquid Petroleum Products by Fluorescent Indicator Adsorption](#)
- [D2274 Test Method for Oxidation Stability of Distillate Fuel Oil \(Accelerated Method\)](#)
- [D2500 Test Method for Cloud Point of Petroleum Products and Liquid Fuels](#)
- [D2622 Test Method for Sulfur in Petroleum Products by Wavelength Dispersive X-ray Fluorescence Spectrometry](#)
- [D2709 Test Method for Water and Sediment in Middle Distillate Fuels by Centrifuge](#)

- [D4052 Test Method for Density, Relative Density, and API Gravity of Liquids by Digital Density Meter](#)
- [D4175 Terminology Relating to Petroleum Products, Liquid Fuels, and Lubricants](#)
- [D4294 Test Method for Sulfur in Petroleum and Petroleum Products by Energy Dispersive X-ray Fluorescence Spectrometry](#)
- [D4485 Specification for Performance of Active API Service Category Engine Oils](#)
- [D4737 Test Method for Calculated Cetane Index by Four Variable Equation](#)
- [D5185 Test Method for Multielement Determination of Used and Unused Lubricating Oils and Base Oils by Inductively Coupled Plasma Atomic Emission Spectrometry \(ICP-AES\)](#)
- [D5453 Test Method for Determination of Total Sulfur in Light Hydrocarbons, Spark Ignition Engine Fuel, Diesel Engine Fuel, and Engine Oil by Ultraviolet Fluorescence](#)
- [D6278 Test Method for Shear Stability of Polymer Containing Fluids Using a European Diesel Injector Apparatus](#)
- [D7422 Test Method for Evaluation of Diesel Engine Oils in T-12 Exhaust Gas Recirculation Diesel Engine](#)
- [E29 Practice for Using Significant Digits in Test Data to Determine Conformance with Specifications](#)

2.2 SAE Standard:⁴

- [SAE J1995 Engine Power Test Code—Spark Ignition and Compression Ignition—Gross Power Rating](#)

3. Terminology

3.1 Definitions:

- 3.1.1 *blind reference oil, n*—a reference oil, the identity of which is unknown by the test facility. **D4175**
- 3.1.2 *blowby, n*—in internal combustion engines, that portion of the combustion products and unburned air/fuel mixture that leaks past piston rings into the engine crankcase during operation.
- 3.1.3 *calibrate, v*—to determine the indication or output of a device (e.g., thermometer, manometer, engine) with respect to that of a standard.
- 3.1.4 *heavy-duty, adj*—in internal combustion engine operation, characterized by average speeds, power output, and internal temperatures that are close to the potential maximums. **D4485**
- 3.1.5 *heavy-duty engine, n*—in internal combustion engine types, one that is designed to allow operation continuously at or close to its peak output.
- 3.1.6 *non-reference oil, n*—any oil other than a reference oil; such as a research formulation, commercial oil, or candidate oil. **D4175**
- 3.1.7 *non-standard test, n*—a test that is not conducted in conformance with the requirements in the standard test method, such as running on an uncalibrated test stand, using different test equipment, applying different equipment assembly procedures, or using modified operating conditions. **D4175**

³ For referenced ASTM standards, visit the ASTM website, www.astm.org, or contact ASTM Customer Service at service@astm.org. For *Annual Book of ASTM Standards* volume information, refer to the standard's Document Summary page on the ASTM website.

⁴ Available from Society of Automotive Engineers, 400 Commonwealth Drive, Warrendale, PA 15096-0001.

3.1.8 *oxidation, n—of engine oil*, the reaction of the oil with an electron acceptor, generally oxygen, that can produce deleterious acidic or resinous materials often manifested as sludge formation, varnish formation, viscosity increase, or corrosion, or a combination thereof.

3.1.9 *reference oil, n*—an oil of known performance characteristics, used as a basis for comparison. **D4175**

3.1.9.1 *Discussion*—Reference oils are used to calibrate testing facilities, to compare the performance of other oils, or to evaluate other materials (such as seals) that interact with oils.

3.1.10 *sludge, n—in internal combustion engines*, a deposit, principally composed of insoluble resins and oxidation products from fuel combustion and the lubricant, that does not drain from engine parts but can be removed by wiping with a cloth. **D4175**

3.1.11 *standard test, n*—a test on a calibrated test stand, using the prescribed equipment that is assembled according to the requirements in the test method, and conducted according to the specified operating conditions.

3.1.12 *varnish, n—in internal combustion engines*, a hard, dry, generally lustrous deposit that can be removed by solvents but not by wiping with a cloth. **D4175**

3.1.13 *wear, n*—the loss of material from a surface, generally occurring between two surfaces in relative motion, and resulting from mechanical or chemical action, or a combination of both. **D7422**

4. Summary of Test Method

4.1 The test operation involves use of a Mack E7-350 diesel engine with a warm-up, a 2 h flush for each test, and then a constant speed and torque conditions that are held for the

remainder of the test. Reference oil test length is 300 h. Non-reference oil test length is 250 h.

4.2 Oil samples are taken periodically and analyzed for viscosity increase.

4.3 Engine rebuild frequency is based on the degradation of test parameters and is left to the discretion of the test laboratory. At rebuild, the power section of the engine is disassembled, solvent-cleaned, measured, and rebuilt, using all new pistons, rings, cylinder liners, and valve guides, in strict accordance with furnished specifications.

4.4 The engine crankcase is solvent-cleaned, and worn or defective parts are replaced.

4.5 The test stand is equipped with appropriate accessories for controlling speed, load, and various engine operating conditions.

5. Significance and Use

5.1 This test method was developed to evaluate the viscometric performance of engine oils in turbocharged and inter-cooled four-cycle diesel engines. Results are obtained from used oil analysis.

5.2 The test method is used for engine oil specification acceptance when all details of the procedure are followed.

6. Apparatus

6.1 General Description:

6.1.1 The test engine is a Mack E7-350 mechanically governed engine, P/N 11GBA77623 (see **Annex A5**). It is an open-chamber, in-line, six-cylinder, four-stroke, turbocharged, charge air-cooled, compression ignition engine. The bore and

TABLE 1 PC-9-HS Reference Diesel Fuel

Property	Test Method	Min ^A	Max ^A
Sulfur, mass %	D2622	0.04	0.05
Gravity, °API	D287 or D4052	34.5	36.5 (37)
Hydrocarbon composition, % vol			
Aromatics	D1319 (FIA)	(27) 28	33
Olefin	D1319 (FIA)		Report
Cetane number	D613	40 (42)	48
Cetane index	D976 and D4737		Report
Copper strip corrosion	D130		1
Flash point, °C	D93	54	
Pour point, °C	D97		−18
Cloud point, °C	D2500		Report
Carbon residue on 10 % residuum, mass %	D524 (10 % bottoms)		0.35
Water and sediment, vol %	D2709		0.05
Viscosity, mm ² /s at 40 °C	D445	2.4	3.0
Ash, mass %	D482		0.005
Acid number	D664		0.05
Strong acid number	D664		0.00
Accelerated stability	D2274		Report
Distillation, °C	D86		
IBP			Report
10 % vol			Report
50 % vol			Report
90 % vol		282	338
EP			Report

^A Min and max numbers in parentheses are EPA Certification Fuel Specifications.

stroke are 124 mm by 165 mm, and the displacement is 12 L. The engine is rated at 261 kW at 1800 r/min governed speed (see SAE J1995).

6.1.2 The ambient laboratory atmosphere should be relatively free of dirt, dust, and other contaminants as required by good laboratory standards. Additionally, it is recommended that the atmosphere in the engine buildup area be filtered and controlled for temperature and humidity to prevent accumulation of dirt or dust on engine parts. Uniform temperature control will also aid in measuring and selecting parts for assembly.

6.1.3 Use the low sulfur reference diesel fuel shown in **Table 1**.

6.2 *The Test Engine:*

6.2.1 *Mack Test Engine*—The engine is available from Mack Trucks, Inc. A complete parts list is shown in **Table A5.1**.

6.2.2 *Engine Cooling System:*

6.2.2.1 A new Mack coolant conditioner shown in **Table A5.1** is required every test to limit scaling in the cooling system. Pressurize the system at the expansion tank to 103 kPa.

6.2.2.2 Use a closed-loop, pressurized external engine cooling system composed of a nonferrous core heat exchanger, reservoir, and water-out temperature control valve. The system should prevent air entrainment and control jacket temperatures within the specified limit. Install a sight glass between the engine and the cooling tower to check for air entrainment and uniform flow in an effort to prevent localized boiling. Block the thermostat wide open.

6.2.3 *Engine Oil System*—A schematic of the engine oil system is shown in **Fig. A2.9**.

6.2.4 *Auxiliary Oil System*—To maintain a constant oil level in the pan, a separate closed tank is connected to the sump that provides an additional 9.5 L sump. Circulate oil through the tank with an auxiliary pump at a rate of 5.7 L/min \pm 1.9 L/min. A typical auxiliary oil system is shown in **Fig. A2.9**. The No. 6 and No. 8 Aeroquip⁵ lines should have inside diameters of 10 mm and 13 mm, respectively. The vent line size is specified as a minimum No. 8 line size. Equivalent lines may be substituted for Aeroquip lines provided they have the proper inside diameters.

6.2.5 *Crankcase Aspiration*—A simple squirrel cage blower will suffice to control crankcase pressure within the test limits.

6.2.6 *Blowby Meter*—Use a displacement type gas meter, or equivalent, to measure blowby.

6.2.7 *Air Supply and Filtration*—Use an intake air filter with an initial efficiency of 99.2 %. Replace filter cartridge when 2.5 kPa ΔP is reached. Install an adjustable valve (flapper) in the inlet air system at least two pipe diameters before any temperature, pressure, and humidity measurement devices. Use the valve to maintain inlet air restriction within required specifications.

6.2.8 *Fuel Supply*—Heating or cooling, or both, of the fuel supply may be required and a recommended system is shown in **Fig. A2.11**.

6.2.9 *Intake Manifold Temperature Control*—Control intake manifold temperature with the use of a slave intercooler.

7. Engine Fluids

7.1 *Test Oil*—Approximately 151 L of test oil are required for the test.

7.2 *Test Fuel*—Use PC-9-HS test fuel^{6,7} from Chevron Phillips. The required fuel properties and tolerances are shown in **Table 1**.

7.3 *Engine Coolant*—Use demineralized water with less than 0.03 g/L of salts or distilled water (do not use antifreeze solutions or other coolant additives).

7.4 *Solvent*—Use only mineral spirits meeting the requirements of Specification **D235**, Type II, Class C for Aromatic Content 0 % vol to 2 % vol, Flash Point (61 °C, min), and Color (not darker than +25 on Saybolt Scale or 25 on Pt-Co Scale). (**Warning**—Combustible. Health hazard.) Obtain a Certificate of Analysis for each batch of solvent from the supplier.

8. Preparation of Apparatus at Rebuild

8.1 *Cleaning of Parts:*

8.1.1 *Engine Block*—Thoroughly spray the engine with solvent (see **7.4**) to remove any oil remaining from the previous test, and air dry.

8.1.2 *Rocker Covers and Oil Pan*—Remove all sludge, varnish, and oil deposits. Rinse with solvent, and air dry.

8.1.3 *Auxiliary Oil System*—Flush all oil lines, galleries, and external oil reservoirs with solvent to remove any previous test oil, and air dry.

8.1.4 *Oil Cooler and Oil Filter*—If heavy deposits are present or suspected, flush the oil cooler and filter lines with solvent to remove any previous test oil, and air dry.

8.1.5 *Cylinder Head*—Clean the cylinder heads using a wire brush to remove deposits and rinse with solvent to remove any sludge and oil, and air dry.

8.2 *Valves, Seats, Guides, and Springs*—Visually inspect valves, seats, and springs for defects and replace, if defective.

8.2.1 Replace and ream guides to 0.9525 cm \pm 0.0013 cm.

8.3 *Cylinder Liner, Piston, and Piston Ring Assembly:*

8.3.1 *Cylinder Liner Fitting*—To ensure proper heat transfer, fit cylinder liners to the block in accordance with the procedure outlined in the Mack Service Manual (see **Annex A5**).

8.3.2 *Piston and Rings*—Cylinder liners, pistons, and rings are provided as a set and should be used as a set. Examine piston rings for any handling damage. Measure piston ring end gaps for conformance with Mack specifications and record.

8.4 *Injectors and Injection Pump:*

8.4.1 *Injectors*—Servicing of injectors is recommended every 1000 h. Resetting of injector opening pressure is allowed if pressure is below specification.

⁶ The sole source of supply for test fuel known to the committee at this time is PC-9-HS Reference Diesel Fuel from Chevron Phillips Chemical Company LP, 10001 Six Pines Drive, The Woodlands, TX 77380.

⁷ If you are aware of alternative suppliers, please provide this information to ASTM Headquarters. Your comments will receive careful consideration at a meeting of the responsible technical committee,¹ which you may attend.

⁵ Aeroquip lines are available at local industrial hose suppliers.

8.4.2 *Injection Pump*—The removal of the injection pump is not recommended unless a problem is noted during a test. Removing the injection pump invalidates the test stand calibration. Replacing injection pumps at each calibration is recommended. New or rebuilt injection pumps may be used and should be obtained from the supplier shown in [A5.3](#). High pressure flow calibration equipment, such as a Bacharach No. 72-7010 standard injector tester, is available from Mack approved dealers. Kent-Moore^{8,7} tool numbers J29539 top dead center indicator and J37077 position sensor are recommended for setting the injection timing.

8.5 *Assembly Instructions:*

8.5.1 *General*—The test parts specified for this test method are intended to be used without material or dimensional modification. Exceptions, for example, is approval of a temporary parts supply problem by the Test Monitoring Center (TMC), and noting of this approval in the test report. All replacement test engine parts shall be genuine Mack Trucks, Inc. parts. Assemble all parts as illustrated in the Mack Service Manual (see [A5.2](#)), except where otherwise noted. Target all dimensions for the means of the specifications. Use the buildup oil (see [Annex A5](#)) for lubricating parts during assembly.

8.5.1.1 *Thermostat*—Block the thermostat wide open using an all thread rod.

8.5.1.2 *Rod Bearings*—Check the condition of the connecting rod bearings. Replacement of the connecting rod bearings is at the laboratory's discretion.

8.5.1.3 *Main Bearings*—Check the condition of the main bearings. Replacement of the main bearings is at the laboratory's discretion.

8.5.1.4 *Piston Undercrown Cooling Nozzles*—Take particular care in assembling the piston undercrown cooling nozzles to ensure proper piston cooling (as outlined in the Mack Service Manual).

NOTE 1—Proper oil pressure is also important to ensure sufficient oil volume for proper cooling.

8.5.2 *New Parts*—Install the following new parts for each rebuild (see [Table A5.1](#), [Annex A5](#), for part numbers):

- 8.5.2.1 Cylinder liners,
- 8.5.2.2 Pistons,
- 8.5.2.3 Piston rings,
- 8.5.2.4 Overhaul gasket set,
- 8.5.2.5 Oil filters (also after each test),
- 8.5.2.6 Engine coolant conditioner (also every test),
- 8.5.2.7 Primary fuel filter (also every test),
- 8.5.2.8 Secondary fuel filter (also every test),
- 8.5.2.9 Valve guides, and
- 8.5.2.10 Valve stem seals.

8.6 *Measurements:*

8.6.1 *Calibrations*—Calibrate thermocouples, pressure gages, speed, and fuel flow measuring equipment prior to each reference test or at any time readout data indicates a need. Conduct calibrations with at least two points that bracket the normal operating range. Make these calibrations part of the

laboratory record. During calibration, connect leads, hoses, and read-out systems in the normally used manner and calibrate with necessary standards. Immerse thermocouples in calibration baths. Calibrate standards with instruments traceable to the National Institute of Standards and Technology on a yearly basis.

8.6.2 *Temperatures:*

8.6.2.1 *General*—Measure temperatures with thermocouples and conventional readout equipment or equivalent. For 0 °C to 150 °C range, calibrate temperature measuring systems to ± 0.5 °C at 100 °C ± 1 °C and to ± 0.5 °C at 0 °C ± 1 °C. Insert all thermocouples so that the tips are located midstream of the flow unless otherwise indicated.

8.6.2.2 *Ambient Air*—Locate thermocouple in a convenient, well-ventilated position between 2 m and 3 m from the engine and hot accessories.

8.6.2.3 *Coolant*—Locate thermocouple in water manifold prior to thermostat housing. Locate in center of water stream (refer to [Fig. A2.5](#)).

8.6.2.4 *Oil*—Locate thermocouple on the right side of the engine on the top of the accessory drive, as shown in [Fig. A2.5](#).

8.6.2.5 *Intake Air*—Locate sensors for dry bulb temperature measurement and humidity in center of air stream at the turbocharger inlet as shown in [Fig. A2.3](#). It is not necessary to control intake air humidity, but measurements are recommended.

8.6.2.6 *Fuel In*—Locate thermocouple in center of fuel line between secondary filter and injection pump, as shown in [Fig. A2.4](#).

8.6.2.7 *Pre-Turbine Temperatures*—Locate one thermocouple in each side of exhaust manifold tee section (see [Fig. A2.3](#)). The exhaust manifold (pre-turbine) thermocouples and pressure taps are located on the same tee.

8.6.2.8 *Exhaust (Tailpipe) Temperature*—Locate thermocouple in exhaust pipe downstream of turbine in accordance with [Fig. A2.7](#).

8.6.2.9 *Intake Manifold*—Locate thermocouple at tapped fitting on intake air manifold, as shown in [Fig. A2.6](#).

8.6.2.10 *Additional*—Monitor any additional temperatures the test lab regards as helpful in providing a consistent test procedure.

8.6.3 *Pressures:*

8.6.3.1 *Before Filter Oil Pressure*—Locate pickup at tapped hole on oil cooler fitting (see [Fig. A2.2](#)).

8.6.3.2 *After Filter/Main Gallery Oil Pressure*—Locate pickup at tapped hole on top of oil filter pad above centrifugal oil filter (see [Fig. A2.2](#)).

NOTE 2—The E7 engine has only one oil gallery, which serves as both a main gallery and a piston cooling gallery.

8.6.3.3 *Pre-Turbine Exhaust Pressure*—Locate pickup in each side of exhaust manifold tee section (same tap as pre-turbine pressure), [Fig. A2.3](#).

8.6.3.4 *Intake Air Boost*—Take measurement at tapped fitting provided on intake manifold, as illustrated in [Fig. A2.6](#).

⁸ The sole source of supply of the tools known to the committee at this time is Kent-Moore Corp., 29784 Little Mack, Roseville, MI 48066.

8.6.3.5 *Intake Air Total Pressure*—Measure with a Keil Probe^{7,9} (p/n No. KDF-8-W recommended) located at the turbo inlet (see Fig. A2.3).

8.6.3.6 *Exhaust Back Pressure*—Locate pickup in exhaust pipe after turbocharger in center of exhaust stream. Measure exhaust back pressure in a straight section of pipe, 30.5 cm to 40.6 cm downstream of the turbo with a 1/16 NPT tread pressure tap hole, as shown in Fig. A2.3.

8.6.3.7 *Crankcase Pressure*—Locate pickup at dipstick tube fitting or other suitable opening direct to the crankcase.

8.6.3.8 *Barometric Pressure*—Locate barometer approximately 1.2 m above ground level in convenient location in the lab.

8.6.4 *Engine Blowby*—Connect the metering instrument to the blowby line coming from the valve cover crossover tube (P/N 191GC418A).

8.6.5 *Fuel Consumption Measurements*—Place the measuring equipment in the fuel line before the primary fuel filter. Install the primary fuel filter before the fuel transfer pump and install the secondary filter before the injection pump. Accurate fuel consumption measurements require proper accounting of return fuel. (**Warning**—Fuel return lines should never be plugged.)

8.6.6 *Humidity*—Place the measurement equipment between the inlet air filter and compressor in such a manner so as not to affect temperature and pressure measurements. Measure humidity at 8 h intervals and report (see Annex A1).

9. Laboratory and Engine Test Stand Calibration/Non-Reference Requirements

9.1 Calibration Frequency:

9.1.1 To maintain test consistency and severity levels, engine test stand calibration is required at regular intervals. The frequency of calibration is dependent on the laboratories' previous calibration experience or at the discretion of the TMC.

9.1.2 Engine test stand calibration is required when the injection pump is removed from the engine, when the front or rear gear train timing is changed, or when cylinder heads are replaced. Cylinder heads and power cylinder components (pistons, rings, and liners) can be rebuilt without re-calibrating. Any rebuild requires a new break-in sequence to be run on the engine prior to testing. Rear gear train timing changes to meet soot targets are only allowed for reference oil tests. Timing changes are limited to a maximum of two changes in the first 100 h of the test. No single timing change can be greater than 1° and the cumulative change shall be $\pm 1^\circ$ from the initial timing.

9.2 Calibration Reference Oils:

9.2.1 The reference oils used to calibrate test stands have been formulated or selected to represent specific chemical types or performance levels, or both. They can be obtained

from the TMC. The TMC assigns reference oils for calibration tests. These oils are supplied under code numbers (blind reference oils).

9.2.2 *Reference Oils Analysis*—Reference oils are not to be submitted to either physical or chemical analysis, for identification purposes. Identifying the oils by analysis could undermine the confidentiality required to operate an effective blind reference oil system. Therefore, reference oils are supplied with the explicit understanding that they will not be subjected to analysis other than those specified within this procedure unless specifically authorized by the TMC. In such cases in which analysis is authorized, written confirmation of the circumstances involved, the data obtained, and the name of the person authorizing the analysis shall be supplied to the TMC.

9.3 *Test Numbering*—Number each test to identify the test stand number, the test stand run number, engine serial number, and engine block hours at the start of the test. The sequential stand run number remains unchanged for reruns of aborted, invalid, or unacceptable calibration tests. However, the sequential stand run number shall be followed by the letter A for the first rerun, B for the second, and so forth. For calibration tests, engine block hours are the test hours since last engine rebuild. For non-reference tests, engine block hours are the test hours accumulated since last reference. For example, 58-12A-2H0380-500 defines a test on stand 58 and stand run 12 as a calibration test that was run twice on engine 2H0380 (serial number), which has run 500 h since the last engine rebuild.

9.4 New Laboratories and New Test Stands:

9.4.1 A new stand is defined as an engine, dynamometer/cell and support hardware that has never been previously calibrated under this test procedure. On both new and existing stands the test engine is part of the stand calibration. A new engine in a existing test stand only requires one successful calibration test.

9.4.2 Calibrate a new test stand in accordance with the Lubricant Test Monitoring System (LTMS). Generally, new test stands require two successful calibration tests. However, provisions do exist within the LTMS to allow new stands to calibrate with one test, based upon previous test experience within the laboratory.

9.4.3 A laboratory not running a test for 12 months from the start of the last test is considered a new laboratory. Under special circumstances (that is, extended downtime due to industry-wide parts shortage or fuel outages) the TMC may extend the lapsed time requirement. Non-reference tests conducted during an extended time allowance shall be annotated (see Annex A1), Downtime and Comments Summary.

9.5 Calibrated Laboratories and Test Stands:

9.5.1 A calibration test on a reference oil assigned by the TMC is required after 3000 h of non-reference test time, ten operationally valid non-reference oil tests, or nine months, whichever comes first, have elapsed since the starting date of the last calibration test. A non-reference test may be started in a test stand provided at least 1 h remains in its calibration period.

⁹ The sole source of supply of Keil Probes known to the committee at this time is United Sensor Corp., 3 Northern Blvd., Amherst, NH 03031.

9.6 Calibration Test Acceptance:

9.6.1 Use the TMC's Lubricant Test Monitoring System (LTMS)¹⁰ for calibration test targets and acceptance criteria.

9.6.2 The specified test parameter for determination of test acceptance is Viscosity Increase in mm²/s, at 100 °C and 3.8 % Thermal Gravimetric Analysis (TGA) soot, as shown in **Annex A3 and Annex A4**.

9.6.2.1 Calculate Viscosity Increase at 3.8 % TGA, using linear interpolation from the minimum viscosity that occurs during the test. Do not use the 25 h, 75 h, and 125 h oil sample results to calculate Viscosity Increase at 3.8 % TGA soot.

9.6.2.2 *Correction Factor for Viscosity Increase at 3.8% TGA Soot*—For all tests completing on or after September 17, 2011, add +0.40 to the value calculated in 9.6.2.1.

9.6.3 Soot Requirements:

9.6.3.1 All operationally valid calibration tests on TMC oil 1004-1 shall produce a TGA soot level between 4.0 % to 4.6 % at 250 h.

9.6.3.2 All operationally valid calibration tests on TMC oil 1004-2 shall produce a TGA soot level between 4.0 % to 4.8 % at 250 h.

9.6.3.3 All operationally valid calibration tests on TMC oil 1004-3 completed on or before Dec. 31, 2006 shall produce a TGA soot level between 4.0 % to 4.8 % at 250 h.

9.6.3.4 All operationally valid calibration tests on TMC oil 1004-3 completed on or after Jan. 1, 2007 and all operationally valid calibration tests on TMC oil 1005-2 shall produce a TGA soot level between 4.0 % to 5.0 % at 250 h.

9.6.3.5 A laboratory may terminate a calibration test that is projected to miss the 250 h test soot window. Calibration tests with soot levels outside the 250 h soot window are considered operationally invalid.

9.7 Failing Calibration Tests:

9.7.1 Failure of a reference oil test to meet test acceptance bands can be indicative of a false alarm, testing stand, testing laboratory, or industry-related problem. When this occurs, the laboratory, in conjunction with the TMC, shall attempt to determine the problem source.

9.7.2 The TMC decides, with input as needed from industry expertise (testing laboratories, test developer, ASTM Technical Guidance Committee, Surveillance Panel, and so forth), if the reason for any unacceptable blind reference oil test is isolated to one particular stand or related to other stands. If it is decided that the problem is isolated to an individual stand, calibrated testing on other stands can continue throughout the laboratory. Alternatively, if it is decided that more than one stand may be involved, the involved stands will not be considered calibrated until the problem is identified, corrected, and an acceptable reference oil test completed in one of the involved stands.

9.7.3 If nonstandard tests are conducted on the referenced test stand, the stand may be required to be recalibrated prior to running standard tests at the discretion of the TMC.

9.8 *Non-Reference Oil Test Requirements*—Non-reference oil tests shall produce a minimum 3.8 % TGA soot level at

250 h. Tests shall run to 250 h regardless of meeting the 3.8 % soot level prior to 250 h. Tests that do not reach 3.8 % soot at 250 h are deemed not interpretable.

NOTE 3—Fixed non-reference oil pass criteria are published in Specification **D4485**.

9.8.1 *Non-Reference Oil Test Result Severity Adjustments*—This test method incorporates the use of a severity adjustment (SA) for non-reference oil test results. A control chart technique, described in the LTMS, has been selected for the purpose of identifying when a bias becomes significant for viscosity increase at 3.8 % TGA soot. When calibration test results identify a significant bias, a SA value is determined in accordance with the LTMS. Report the SA value (see **Annex A1**), Test Result Summary, under the non-reference oil test block in the space for SA. Add this SA value to non-reference oil test results, and enter the adjusted viscosity increase at 3.8 % TGA soot value in the appropriate space. The SA remains in effect until a new SA is determined from subsequent calibration tests, or the test results indicate the bias is no longer significant.

9.9 *Donated Reference Oil Test Programs*—The surveillance panel is charged with maintaining effective reference oil test severity and precision monitoring. During times of new parts introductions, new or re-blended reference oil additions, and procedural revisions, it may be necessary to evaluate the possible effects on severity and precision levels. The surveillance panel may choose to conduct a program of donated reference oil tests in those laboratories participating in the monitoring system, in order to quantify the effect of a particular change on severity and precision. Typically, the surveillance panel requests its panel members to volunteer enough reference oil test results to create a robust data set. Broad laboratory participation is needed to provide a representative sampling of the industry. To ensure the quality of the data obtained, donated tests are conducted on calibrated test stands. The surveillance panel shall arrange an appropriate number of donated tests and ensure completion of the test program in a timely manner.

9.10 Adjustments to Reference Oil Calibration Periods:

9.10.1 *Procedural Deviations*—On occasions when a laboratory becomes aware of a significant deviation from the test method, such as might arise during an in-house review or a TMC inspection, the laboratory and the TMC shall agree on an appropriate course of action to remedy the deviation. This action may include the shortening of existing reference oil calibration periods.

9.10.2 *Parts and Fuel Shortages*—Under special circumstances, such as industry-wide parts or fuel shortages, the surveillance panel may direct the TMC to extend the time intervals between reference oil tests. These extensions shall not exceed one regular calibration period.

9.10.3 *Reference Oil Test Data Flow*—To ensure continuous severity and precision monitoring, calibration tests are conducted periodically throughout the year. There may be occasions when laboratories conduct a large portion of calibration tests in a short period of time. This could result in an unacceptably large time frame when very few calibration tests are conducted. The TMC can shorten or extend calibration

¹⁰ The lubricant test monitoring system may be obtained from the ASTM Test Monitoring Center, 6555 Penn Ave., Pittsburgh, PA 15206-4489. Attention: Administrator.

periods as needed to provide a consistent flow of reference oil test data. Adjustments to calibration periods are made such that laboratories incur no net loss (or gain) in calibration status.

9.10.4 *Special Use of the Reference Oil Calibration System*—The surveillance panel has the option to use the reference oil system to evaluate changes that have potential impact on test severity and precision. This option is only taken when a program of donated tests is not feasible. The surveillance panel and the TMC shall develop a detailed plan for the test program. This plan requires all reference oil tests in the program to be completed as close to the same time as possible, so that no laboratory/stand calibration is left in an excessively long pending status. In order to maintain the integrity of the reference oil monitoring system, each reference oil test is conducted so as to be interpretable for stand calibration. To facilitate the required test scheduling, the surveillance panel may direct the TMC to lengthen and shorten reference oil calibration periods within laboratories such that the laboratories incur no net loss (or gain) in calibration status.

10. Procedure

10.1 Pretest Procedure:

10.1.1 *Initial Oil Fill for Flush*—The initial oil fill is 45.4 L of test oil: 26.5 L for the pan, 3.8 L for the filters, 1.9 L for the engine oil cooler, and 13.2 L for the auxiliary oil reservoir and lines. Add the first 3.8 L of fresh test oil to the oil filters (1.9 L per filter), then turn on the auxiliary oil pumps and add an additional 41.6 L of test oil to the engine. This oil can be added directly through the engine oil fill tube.

10.1.2 Pretest Oil Flush and Break-In:

10.1.2.1 Start the engine, as described in 11.2. For a new or rebuilt engine, run the break-in sequence described in Table 2. For non-reference oil tests only a pretest oil flush procedure is required. A post test flush should be done prior to a pretest, as described in 10.13.1 and 10.13.2.

10.1.2.2 Shutdown the engine (as shown in 11.3) and drain the test oil from the oil pan, external oil reservoir, and change the oil filters.

10.1.2.3 Install new oil filters and add 3.8 L of fresh test oil to the filters (1.9 L per filter). Start the auxiliary oil pumps and add an additional 41.6 L of new oil to the engine. This oil can be added directly through the engine oil fill tube.

10.2 *Engine Start-Up*—Each time the engine is started, work up to 20 % to 30 % of full load at 1000 r/min to 1400 r/min and hold until the oil sump temperature reaches approximately 66 °C to 77 °C. This takes about 10 min for a cold engine; then go to test conditions. Start-ups are not included as test time. Test time starts as soon as the engine

TABLE 2 Break-in and Flush Operating Conditions

Conditions	New or Rebuild Break-in		Pretest Flush
Time, min	30	30	120
Speed, r/min	1250	1800	1800
Torque, N·m ^A ± 1 % ^B	1731 (1277)	1384 (1021)	1384 (1021)

^A At 98.2 kPa and 29.5 °C dry air.

^B When engine performance falls outside these limits, corrective action should be taken.

returns to the test cycle. The start date and time of a test, is defined as when the test reaches test conditions (after a flush). (**Warning**—The engine should be cranked prior to start-up to fill the engine oil passages. This practice will enhance engine durability significantly.)

10.3 *Engine Shutdown*—The engine may be shut down for periods of time. Before each shutdown, operate the engine at 1000 r/min to 1400 r/min no-torque for 10 min, then close the fuel rack. The shutdown operation does not count as test time. Record the length and reason of each shutdown (see Annex A1).

10.4 *Test Cycle*—The test cycle includes a pretest oil flush at the conditions shown in Table 2. For new and rebuilt engines, a break-in procedure is also required. Conduct the test at 1800 r/min full-torque conditions as described in Table 3. Reference oil test length is 300 h. Non-reference oil test length is 250 h.

10.4.1 At EOT (end of test), the average results for all controlled operational parameters shall be within the stated specifications for the test to be declared operationally valid. For calibration tests, investigate any uncontrolled operational parameters outside the stated specifications jointly by the laboratory and the TMC. Base a validity judgment on the joint agreement between the laboratory and the TMC.

10.5 *Oil Addition/Drain*—Establish the *full mark* as the oil mass in the first 1 h period of the test. At the end of every 25 h period, perform a forced drain that equates to an oil consumption of 0.243 g/kWh. If a sample is required, follow the guidelines set forth in 10.6. If a sample is not required, then drain a sufficient amount of oil to obtain an oil mass that is below the *full mark* by 1.59 kg. Then add 1.59 kg of new oil

TABLE 3 Test Conditions

Parameter	Limits
Time, h	250 (300 for reference oils)
Controlled Parameters ^A	
Speed, r/min	1800 ± 5
Fuel flow, kg/h	63.3 ± 1 %
Inlet manifold temperature, °C	43 ± 3
Coolant out, °C	85 ± 3
Fuel in, °C	40 ± 1
Intake air, °C	25 ± 3
Crankcase pressure, kPa	0.50 ± 0.25
Inlet air restriction, kPa	2.50 ± 0.25
Exhaust back pressure, kPa	3.1 ± 0.4
Uncontrolled Parameters	
Torque, N·m ^B	1369/1398 ^C
Exhaust temperature, °C	
Pre-turbine	602/632
Tailpipe	455/474
Inlet manifold pressure, kPa	186/199 ^C
Oil, °C	100/107
Main gallery oil pressure, kPa	372/441 ^D
Intercooler ΔP, kPa	Not to exceed 13.6
Oil filter ΔP, kPa	Not to exceed 138 ^E

^A All control parameters are to be held at the mean indicated.

^B At 98.2 kPa and 29.5 °C dry air.

^C When engine performance falls outside these limits, corrective action should be taken. Fuel flow is the primary control parameter.

^D Note pressures are typical of SAE 15W40 oils; other oil grades may show different results.

^E If oil filter ΔP exceeds 138 kPa, change the two full flow filters.

to the engine. After a shutdown, use the drain level of the previous period to determine the forced drain quantity.

NOTE 4—The kWh symbol is not an SI unit symbol. The equivalent SI unit symbol is J (joule); 1 kWh = 3.6 MJ.

10.6 Oil Samples:

10.6.1 For reference oil tests, take oil samples of 118 mL at 25 h intervals. For non-reference oil tests, the 25 h, 75 h, and 125 h samples are optional. Obtain oil samples through a drain petcock located in the oil rig return line (oil pan to return pump) (see Fig. A2.8).

10.6.2 If oil consumption during a 25 h period is less than or equal to 1.02 kg, withdraw a 473 mL purge, then withdraw a 118 mL sample. Then drain enough oil to complete the forced drain of 1.59 kg (including mass of the 473 mL purge).

10.6.3 If the oil consumption is greater than 1.02 kg, withdraw a 473 mL purge and then a 118 mL sample. Then return the purge oil to the external oil reservoir. Then drain an amount of oil equal to the difference of the oil consumption of that period from 1.59 kg. Then follow with the forced oil addition of 1.59 kg of new oil.

10.7 Oil Consumption Calculations:

10.7.1 Record the oil mass hourly and compute the oil consumption from these readings.

10.7.2 Calculate the average oil consumption for the test as the average of the 25 h periods from 26 h to end of test. Do not use the first 25 h period to calculate oil consumption since this is a period of stabilization of the oil scale system. Do not include oil drains and samples as oil consumption.

10.7.3 Use the following formula to calculate the oil consumption for a 25 h period:

$$\text{Oil Consumption (g/kWh)} = (FW - W_n)/(P \times 25) \quad (1)$$

where:

FW = full mass, g,

W_n = oil scale mass at n test hours before additions, samples, or drains, g, and

P = brake power output of the engine, kW.

The reported oil consumption is the average of the 25 h period oil consumption calculations.

10.7.4 The full mass may need to be reestablished, depending on the rate of oil consumption of the engine for the 25 h period. If the oil consumption is greater than 0.225 g/kWh, recalculate the full mass by subtracting the mass of the oil sample and adding the mass of the oil addition (1.59 kg) to the previous 25 h period's mass.

10.8 Fuel Samples—Take fuel samples prior to the start of test (two 0.95 L samples) and at EOT (two 0.95 L samples).

10.9 Periodic Measurements—Make measurements at the end of each test hour or more frequently, if desired, on the parameters listed in 10.9.1 and record (see Annex A1). Record data before adjustments are made to control parameters to achieve operation at specification mean. Each measurement is to be an hourly snapshot. The TMC encourages automatic data acquisition and permits multiple measurements to be made within an hour. Characterize the procedure used to calculate the hourly average (see Annex A1).

10.9.1 Parameters:

10.9.1.1 Speed, r/min,

10.9.1.2 Torque, N·m,

10.9.1.3 Oil temperature, °C,

10.9.1.4 Water-out temperature, °C,

10.9.1.5 Water-in temperature, °C,

10.9.1.6 Intake air temperature, °C,

10.9.1.7 Intake manifold temperature, °C,

10.9.1.8 Intake air boost, kPa,

10.9.1.9 Fuel flow, s/kg or kg/h,

10.9.1.10 Fuel inlet temperature, °C,

10.9.1.11 Tailpipe exhaust back pressure, kPa,

10.9.1.12 Before filter oil pressure, kPa,

10.9.1.13 Main gallery oil pressure, kPa,

10.9.1.14 Crankcase pressure, kPa,

10.9.1.15 Pre-turbine exhaust temperature, front manifold, °C,

10.9.1.16 Pre-turbine exhaust temperature, rear manifold, °C,

10.9.1.17 Inlet restriction, kPa,

10.9.1.18 Tailpipe exhaust temperature, °C,

10.9.1.19 Crankcase blowby, L/min (see 10.9),

10.9.1.20 Pre-turbine exhaust pressure, front manifold, kPa,

10.9.1.21 Pre-turbine exhaust pressure, rear manifold, kPa, and

10.9.1.22 Inlet air humidity, g/kg.

10.10 Blowby—Record the total crankcase blowby at a minimum of 8 h intervals. Disconnect crankcase aspirating equipment during blowby measurements. Take care to prevent oil traps from occurring in the blowby line at any time during operation.

10.11 Centrifugal Oil Filter Mass Gain—Prior to the start of test, determine the mass of the centrifugal oil filter canister. At EOT, remove the centrifugal oil filter canister from the engine and drain upside down for 30 min. After draining, determine the mass of the canister and record (see Annex A1). Centrifugal oil filter mass gain determination is required for calibration tests and optional for non-reference oil tests.

10.12 Oil Filter ΔP Calculation:

10.12.1 The reported oil filter ΔP is the maximum oil filter ΔP that occurs from (0 to 250) h. Calculate the oil filter ΔP as follows:

$$\Delta P = \Delta P_{\max} - \Delta P_{\text{initial}} \quad (2)$$

where:

ΔP_{\max} = the maximum ΔP across the oil filter, and

$\Delta P_{\text{initial}}$ = the ΔP across the oil filter at the start of test conditions.

10.12.2 If an oil filter change is made, add the oil filter ΔP value obtained after the filter change to the oil filter ΔP obtained prior to the filter change. If a shutdown occurs, add the oil filter ΔP value obtained after the shutdown to the oil filter ΔP obtained prior to the shutdown.

10.13 Post Test:

10.13.1 Post Test Flush—As soon as possible after the EOT, perform a post test flush. Drain all oil from the oil pan, external oil reservoir, and filters. Perform an initial fill in accordance

with 10.1, and use Bulldog Premium Oil^{7,11} as the flush oil. Start the engine as described in 10.2 and run the pretest flush conditions as described in Table 2. Shutdown the engine (see 10.3) and drain the post test flush oil from the oil pan, external oil reservoir, and remove filters.

10.13.2 *Post Test Solvent Wash*—After the post test flush is performed, wash the top of the cylinder heads (rocker area), rocker arms, and rocker covers with solvent until clean. The oil drain plug should be open for this procedure. Remove the oil pan and wash with solvent until clean. Also wash the external oil rig system and the external oil lines with solvent until clean.

11. Inspection of Fuel and Oil During Test

11.1 Oil Inspection:

11.1.1 Analyze oil samples for viscosity at 100 °C in accordance with Annex A3; poor test precision can result if the modified test method (see Annex A3) is not followed exactly. To maintain test accuracy and precision, conduct all viscosity and soot measurements at a TMC-calibrated laboratory. Take two samples at 250 h and analyze for viscosity and soot. In Annex A1, the viscosity reported is the average of the two samples taken at 250 h. Base viscosity increase on the minimum viscosity as reported in Annex A1. In addition to the viscosity measurements, conduct soot analysis in accordance with Annex A4. Determine wear metals content (Fe, Pb, Cu, Cr, Al); additive metals content, silicon, and sodium levels in accordance with Test Method D5185 from new, 150 h, 250 h, and 300 h (if applicable) oil samples. Conduct oil analysis as soon as possible after sampling.

11.2 *Fuel Inspections*—Use fuel purchase inspections to complete forms in Annex A1 for the last batch of fuel used during the test. If more than one batch is used for a test, list each fuel batch in the fuel batch identifier block in Annex A1. List the fuel batches in chronological order (initial to final batch). In addition, perform the following inspections on NEW and EOT fuel samples:

- (1) API Gravity at 15.6 °C, Test Method D287
- (2) Total Sulfur, mass %, Test Method D5453 (Test Methods D2622 or D4294 can be substituted)
- (3) Use one 0.95 L sample for inspections

11.3 Oil Consumption:

11.3.1 Compute total oil consumption for the test and report in kilograms per kilowatt-hour for each test. A value of 0.182 g/kWh or lower is desirable. For calibration tests, if oil consumption exceeds 0.304 g/kWh, the test is considered operationally invalid. Oil consumption greater than 0.304 g/kWh requires further investigation of the test oil or the engine, or both, to determine the cause.

11.3.2 The recommended oil consumption rig plumbing is shown in Fig. A2.8.

12. Report

12.1 *Reporting Test Results*—For reference oil tests, the standardized report form and data dictionary for reporting the

TABLE 4 T-8 Precision Data

Parameter	Intermediate Precision (i.p.)	Reproducibility (R)
Viscosity increase at 3.8 % TGA soot	2.51	2.53
Relative viscosity at 4.8 % TGA soot (50 % DIN shear loss)	0.62	0.64
Relative viscosity at 4.8 % TGA soot (100 % DIN shear loss)	0.67	0.70

test results and for summarizing the operational data are required. The report forms and data dictionary are available on the ASTM Test Monitoring Center Web Page at <http://www.astmtmc.cmu.edu/> or can be obtained in hard copy format from the TMC.

12.1.1 During the test, if the engine is shut down or operated out of test limits, record the engine hours, time, and date (see Annex A1). In addition, note in the comment section all prior reference oil tests that were deemed operationally or statistically invalid or aborted.

12.1.2 When reporting reference oil test results, transmit the test data electronically by utilizing the ASTM Data Communications Committee Test Report Transmission Model, which is available from the TMC. Transmit the data within five working days of test completion.

12.2 *Deviations from Test Operational Limits*—Report all deviations from specified test operational limits (see Annex A1), Other Comments.

12.3 *Electronic Transmission of Test Results*—Electronic transfer of the test report can be done utilizing the ASTM Data Communications Committee Test Report Transmission Model (see Section 2—Flat File Transmission Format) available from the ASTM TMC.

12.4 *Plots of Operational Data*—Graphical representation of operational data is required. Place graphs on 216 mm by 219 mm portrait oriented paper. The x-axis (hours) shall be 127 mm in length and segmented into 10 h increments with hour labels at 50 h increments.

13. Precision and Bias¹²

13.1 *Precision*—Test precision is established on the basis of operationally valid reference oil test results monitored by the ASTM TMC. The research report contains industry data developed prior to establishment of this test method. Practice E29 was used as a guide to develop this data.

13.1.1 *Intermediate Precision (formerly called repeatability) Conditions*—Conditions where test results are obtained with the same test method using the same test oil, with changing conditions such as operators, measuring equipment, test stands, test engines, and time.

13.1.1.1 *Intermediate Precision Limit (i.p.)*—The difference between two results obtained under intermediate precision conditions that would in the long run, in the normal and correct conduct of the test method, exceed the values shown in Table 4 in only one case in twenty.

¹¹ The sole source of supply of Bulldog Premium Oil known to the committee at this time is Mack Truck suppliers or Mack Trucks, Inc., 13302 Pennsylvania Ave., Hagerstown, MD 21742.

¹² Supporting data have been filed at ASTM International Headquarters and may be obtained by requesting Research Report RR:D02-1324.

13.1.2 *Reproducibility Conditions*—Conditions where test results are obtained with the same test method using the same test oil in different laboratories with different operators using different equipment.

13.1.2.1 *Reproducibility Limit (R)*—The difference between two results obtained under reproducibility conditions that would, in the long run, in the normal and correct conduct of the test method, exceed the values in Table 4 in only one case in twenty.

13.1.3 The test precision, as of July 9, 2015, is shown in Table 4.

13.1.4 The TMC can furnish current precision information.

13.2 *Bias*—Bias is determined by applying an accepted statistical technique to reference oil test results and when a significant bias is determined, a SA is permitted for non-reference oil test results (see 9.8.1).

14. Keywords

14.1 diesel engine oil; lubricants; soot; T-8 diesel engine; viscosity

ANNEXES

(Mandatory Information)

A1. REPORT FORMS

A1.1 The required report forms are available on the ASTM Test Monitoring Center Web Page at <http://www.astmtmc.cmu.edu/> or can be obtained in hard copy format from the TMC.

Form 0	Cover Sheet
Form 1	Test Result Summary
Form 2	Operational Summary
Form 3	Viscosity Increase versus Time

Form 4	Oil Analysis Summary
Form 5	Test Fuel Analysis
Form 6	Downtime and Comments
Form 7	Characteristics of the Data Acquisition System
Form 8	Buildup and Hardware Information
Forms 9–12	Operating Data
Form 13	Rotational Viscosity Data

A2. SENSOR LOCATIONS

A2.1 Properly locating the sensor devices is important to this test. Figs. A2.1-A2.11 indicate the sensor locations for the T-8 engine components.

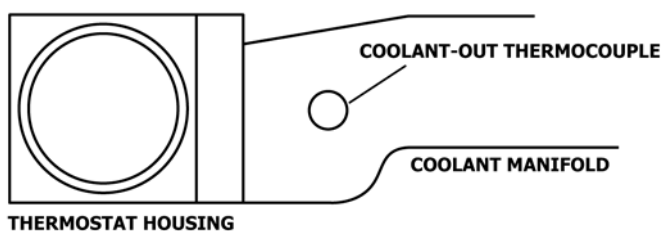

FIG. A2.1 Coolant-out Thermocouple Location (Top View)

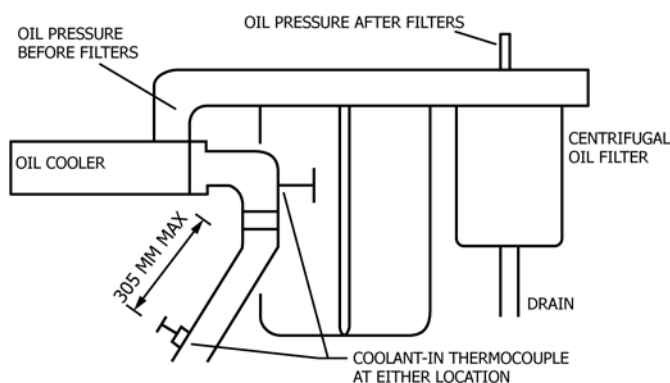

FIG. A2.2 Oil Pressure Taps and Coolant-in Thermocouple Locations

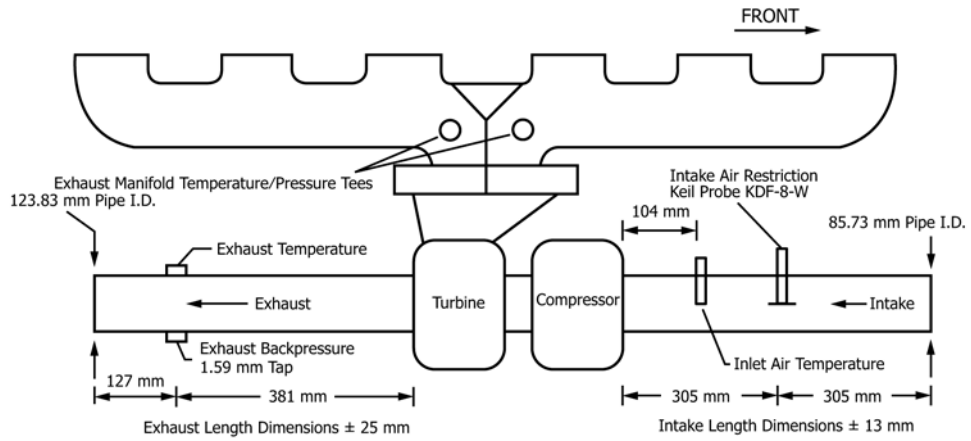

FIG. A2.3 Intake Pipe, Exhaust Manifold, and Exhaust Pipe Temperature and Pressure Sensor Locations

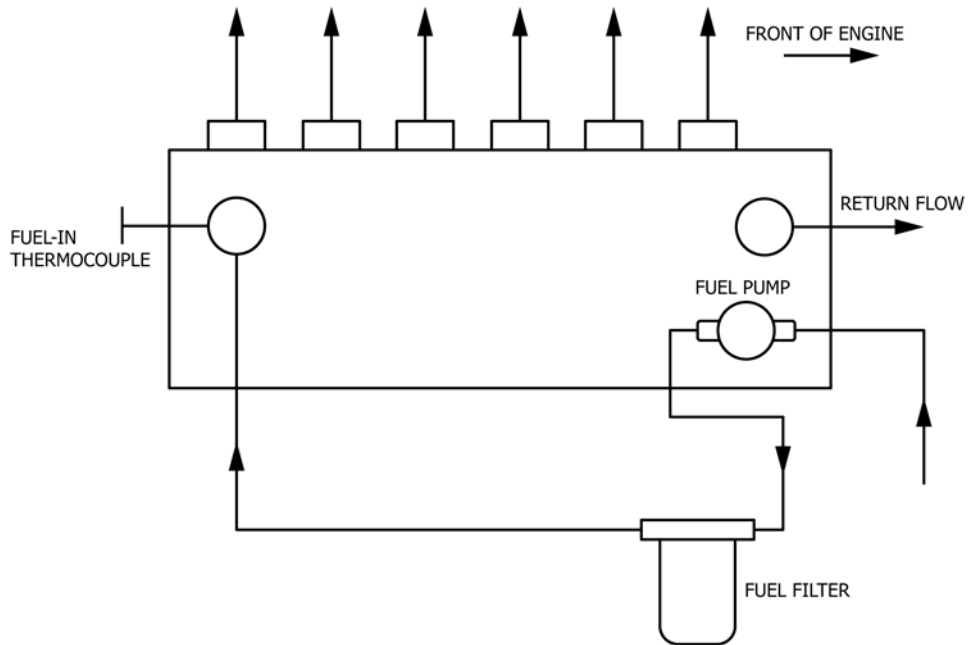

FIG. A2.4 Fuel-in Thermocouple Location

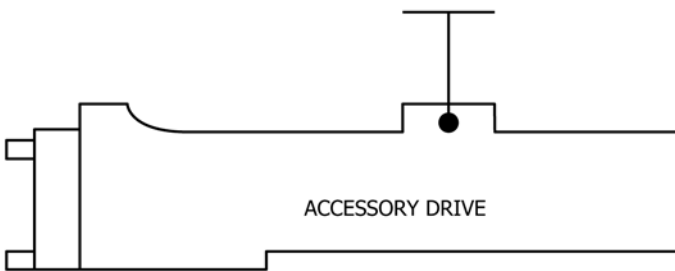

FIG. A2.5 Oil Temperature Thermocouple Location

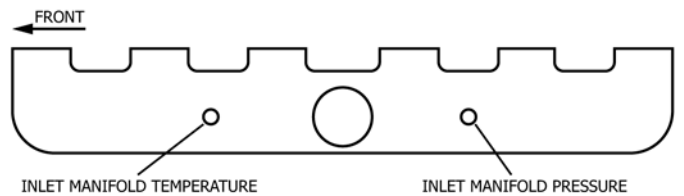

FIG. A2.6 Inlet Manifold Temperature and Pressure Sensor Locations

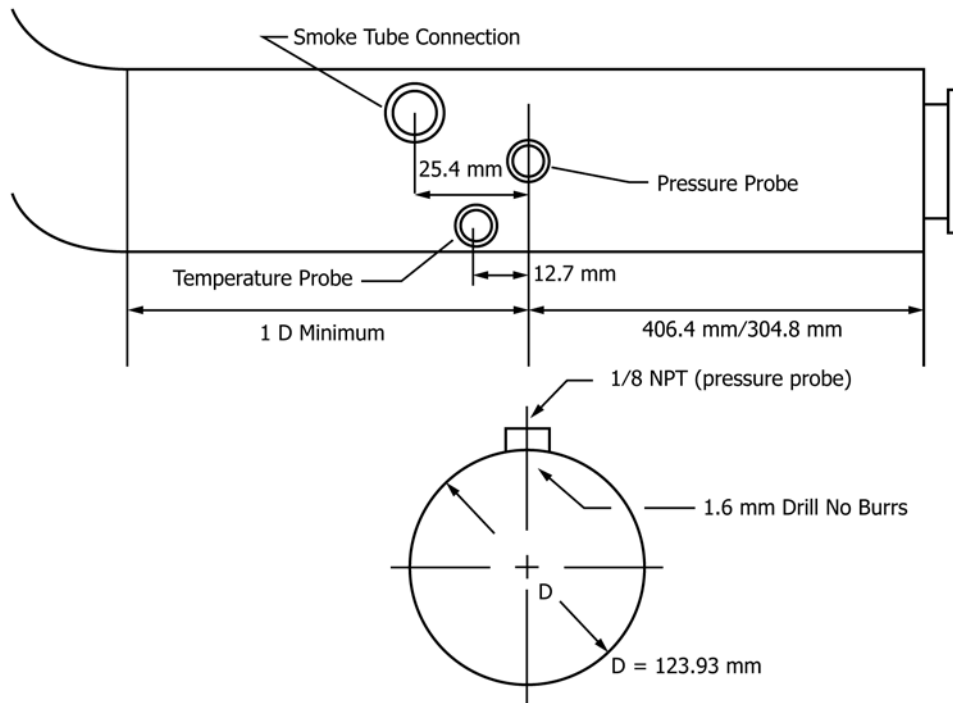
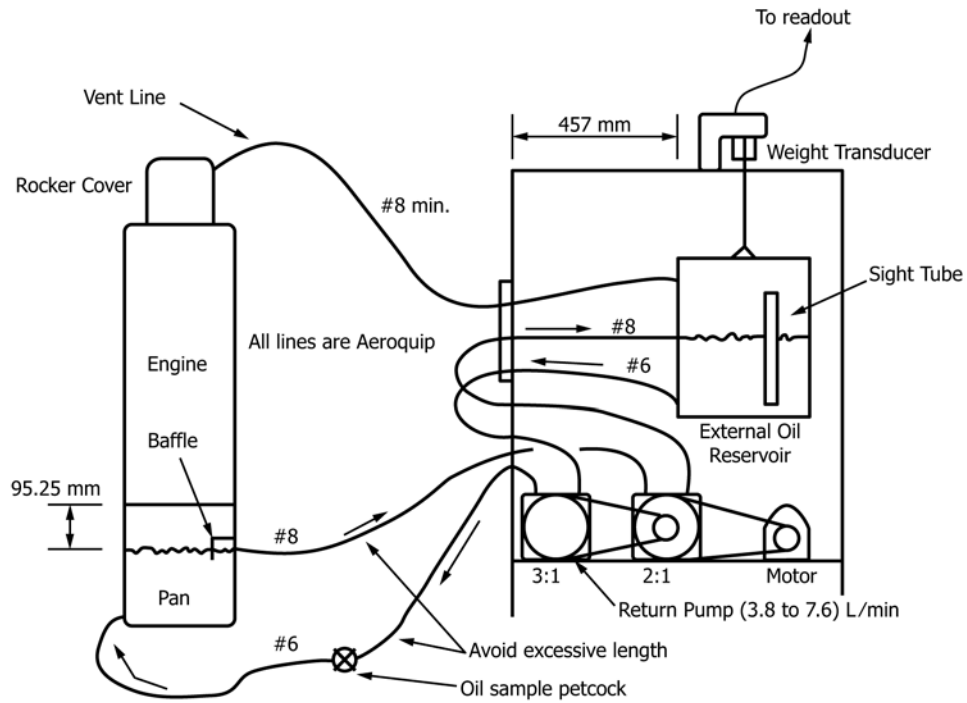
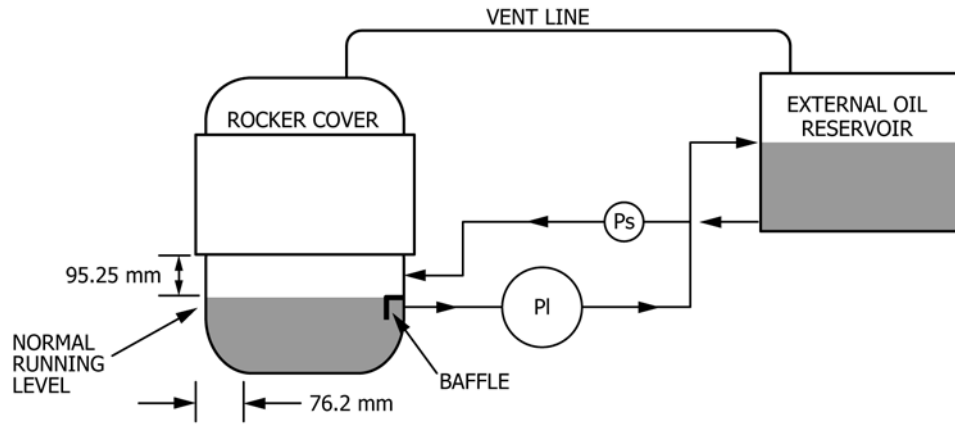

FIG. A2.7 Exhaust Tube



Recommended pump specifications: Draw pump - #1 Browne & Sharpe
 Return pump - #1 Browne & Sharpe

FIG. A2.8 Oil Rig Plumbing



Ps - SMALLER PUMP CAPACITY (3.8 to 7.6) L/min
 PI - LARGER PUMP CAPACITY

FIG. A2.9 Auxiliary Oil System

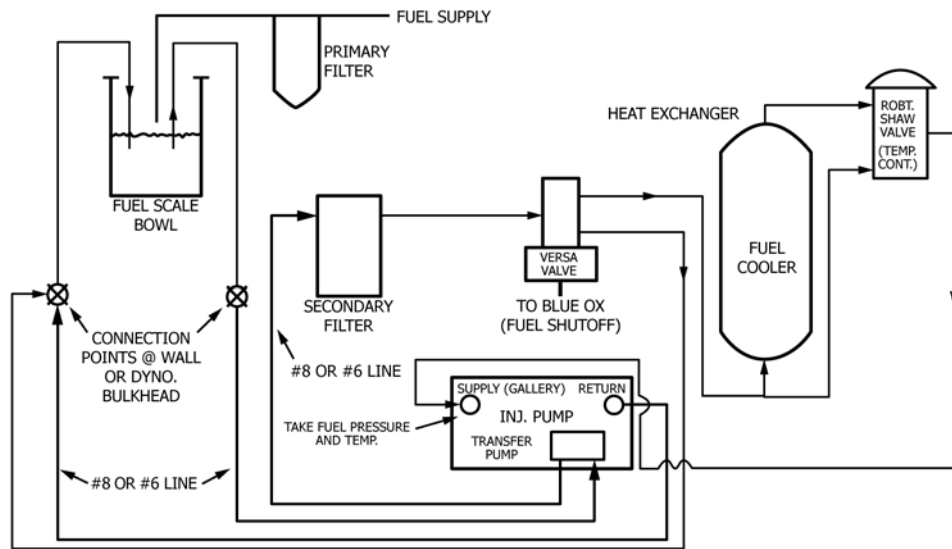

FIG. A2.10 Test Cell Fuel System Schematic

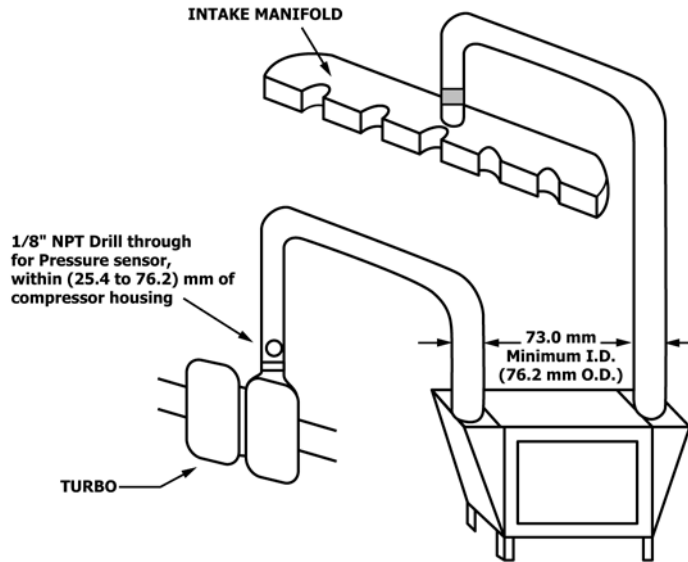

FIG. A2.11 Test Cell *Slave* Intercooler Arrangement

A3. KINEMATIC VISCOSITY AT 100 °C FOR TEST METHOD D5967 SAMPLES

A3.1 This procedure follows Test Method D445-96 except for some modifications and additions.

A3.2 Oil Samples

A3.2.1 Use a 200 reverse flow tube for analyzing all samples. However, if the flow time is greater than 1000 s, a 300 reverse flow tube should then be used. For flows exceeding the 1000 s and the mm²/s range given for a 300 reverse flow tube, follow what is stated in Fig. A3.2 of Test Method D446.

A3.2.1.1 To maintain accuracy and precision, the following ranges for tube constants, are recommended:

- (1) 200 reverse flow tube: 0.09 (mm²/s)/s to 0.12 (mm²/s)/s.
- (2) 300 reverse flow tube: 0.22 (mm²/s) to 0.28 (mm²/s)/s.

A3.2.2 The following precautions are recommended:

A3.2.2.1 Viscosity and soot (see Annex A4, D5967) should be measured before any other analysis is performed on the sample.

A3.2.2.2 Viscosity results may be affected if the sample container is not full. Additionally, results may be affected if any oil has been removed from the sample without the sample being shaken per 2.4.

A3.2.3 Follow portions of Section 11 of Test Method D445, procedure for opaque liquids, as outlined here; two tubes, first bulb measurement only.

A3.2.4 Shake all oil samples using the following procedure. This procedure requires a Red Devil Model 5600 Commercial Paint Shaker, or equivalent. Model 5600 subjects the sample to a 497 r/min in a circular motion with a 22.23 mm radius. The springs that hold the machine also provide some up and down

motion to the sample. Do not prepare more than two samples (four tubes) at the same time.

- A3.2.4.1 Be sure cap is tight on the sample container.
- A3.2.4.2 Place the sample on the paint shaker.
- A3.2.4.3 Shake for 5 min.
- A3.2.4.4 Remove sample container from paint shaker.

A3.2.4.5 Portions of the sample can now be taken for analysis. No more than 2 min should pass between A3.2.4.4 and the charging of the viscosity tubes.

A3.2.5 Follow 11.4 of Test Method D445; two viscometers should be charged. It is not necessary to heat the sample. Allow the sample to be drawn up to ~ 6.4 mm past the fill line (see Fig. A3.1).

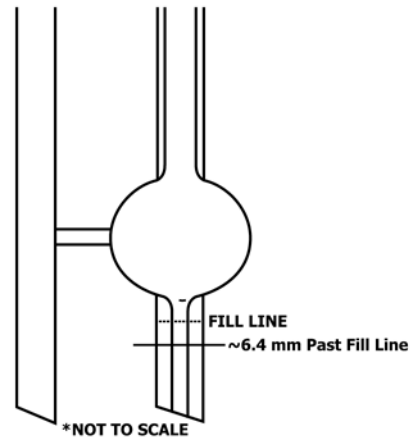

FIG. A3.1 Viscometer Fill Line

A3.2.6 Invert the tube to an upright position and wipe excess sample off of Tube N with a Kimwipe or clean soft cloth.

A3.2.7 Referring to Fig. A3.2, allow the sample to flow $\sim 3/4$ the length of the capillary, Tube R. Vacuum or pressure may be necessary to accomplish this.

A3.2.8 Use a stopper to prevent the sample from flowing in the tube.

A3.2.8.1 The sample shall not reach the first timing mark E as this will void the test!!

A3.2.8.2 Once the viscosity tubes have been charged, immediately place them into the bath. Once the tubes have been inserted into the bath, do not insert or remove other tubes or equipment until the test is completed.

A3.2.9 Follow 11.4.1 of Test Method D445. Please note that the viscometer should be mounted upright in the desired bath keeping Tube L vertical. Ensure the bath liquid level is above Bulb D. A bath soak time of $900\text{ s} \pm 30\text{ s}$ is to be used. The bath soak time is the time from when the tubes are inserted into the bath until the oil passes the first timing mark.

A3.2.10 With the sample flowing freely, once the oil comes into contact with the first timing Mark E, immediately start the timer (see Fig. A3.3). At the start of the test, the temperature control and measurement requirements stated in 6.3 and 6.4 of Test Method D445 shall be met.

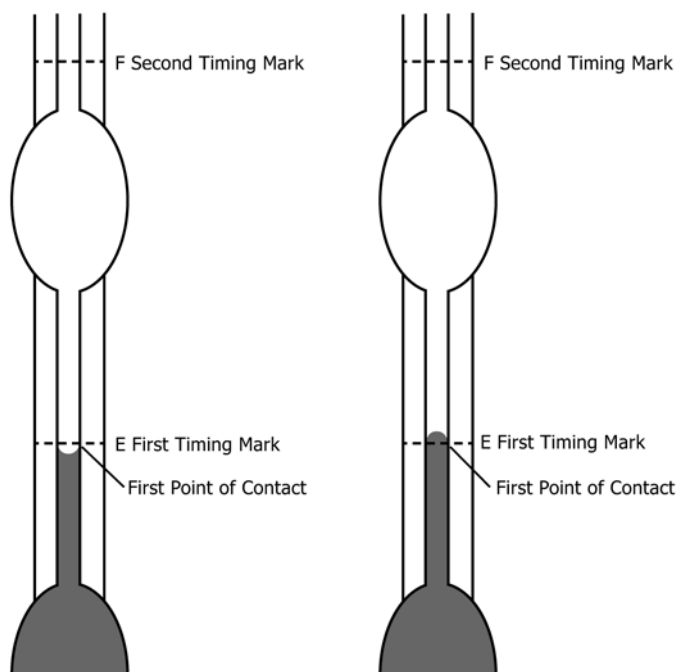

FIG. A3.3 First Timing Mark

A3.2.11 Measure the time required for the oil ring of contact to pass from the first timing Mark E to the second timing Mark F. As soon as the oil ring of contact reaches F, stop the timer (see Fig. A3.4).

A3.2.12 Finally, follow 11.6 of Test Method D445. Report the viscometer results individually, and report the average.

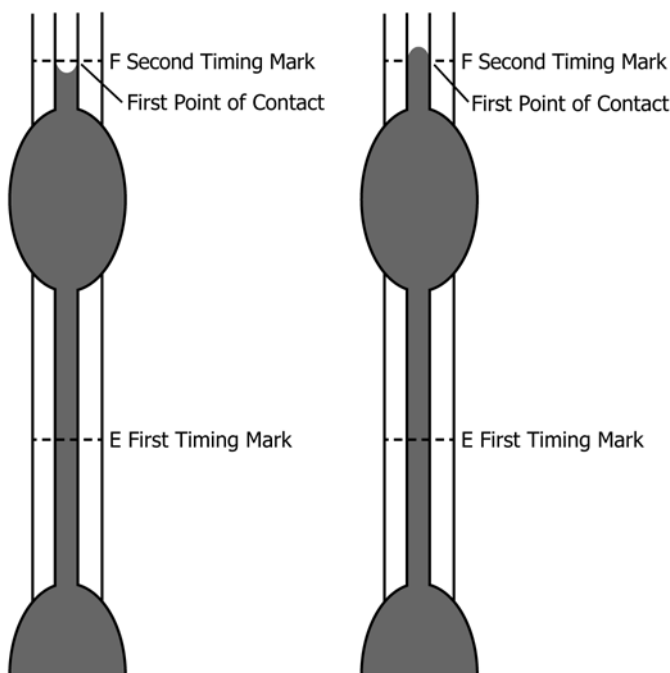

FIG. A3.4 Second Timing Mark

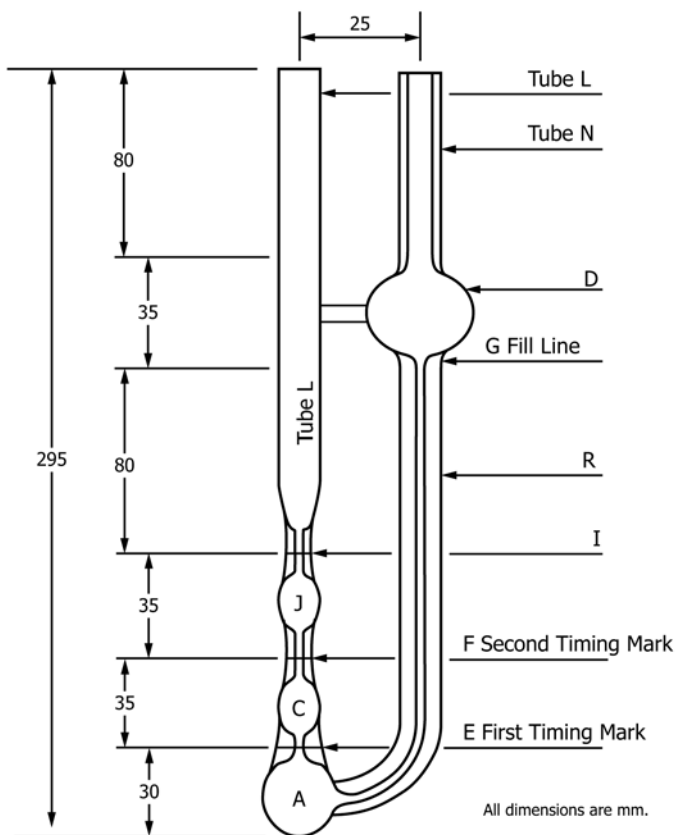

FIG. A3.2 Reverse Flow Viscometer

A3.3 Used Oil Samples

A3.3.1 A 200 reverse flow tube shall be used for analyzing all samples. However, if the flow time is greater than 1000 s, a 300 reverse flow tube should then be used. For flows exceeding the 1000 s and the mm²/s range given for a 300 reverse, follow what is stated in Fig. A3.2 of Test Method D446.

A3.3.2 Portions of Section 11 of Test Method D445 follow procedure for Opaque Liquids; two tubes, first bulb measurement only. It is not necessary to heat or filter the sample.

A3.3.3 Shake all used oil samples using the following procedure. This procedure requires a Red Devil Model 5600 Commercial Paint Shaker, or equivalent. Model 5600 subjects the sample to 497 r/min in a circular motion with a 22.23 mm radius. The springs that hold the machine also provide up and down motion to the sample. Do not prepare more than two samples (four tubes) at the same time.

A3.3.3.1 Be sure cap is tight on sample container.

A3.3.3.2 Place the sample on the paint shaker.

A3.3.3.3 Shake for 5 min.

A3.3.3.4 Remove sample container from paint shaker.

A3.3.3.5 Portions of the sample can now be taken for analysis. No more than 2 min should pass between A3.3.4 and charging of the viscosity tubes.

A3.3.4 Follow 11.4 of Test Method D445. As called for, two viscometers should be charged. It is not necessary to heat the

sample. Allow the sample to be drawn up to ~6.4 mm past the fill line (see Fig. 1 of Test Method D445).

A3.3.5 Invert the tube to an upright position and wipe excess sample off of Tube N with a Kimwipe or clean soft cloth.

A3.3.6 Referring to Fig. 2 of Test Method D445, pull a vacuum on Tube L drawing sample to ~³/₄ the length of the capillary, Tube R.

A3.3.7 Place stopper on the end of Tube N to prevent the sample from flowing in the tube.

A3.3.7.1 The sample shall not reach the first timing Mark E as this will void the test!!

A3.3.8 Follow 11.4.1 of Test Method D445. Please note that the viscometer should be mounted upright in the desired bath keeping Tube L vertical. Ensure the bath liquid level is above Bulb D. A bath soak time of 15 min ± 30 s is to be used.

A3.3.9 With the sample flowing freely, once the oil comes in contact with the first timing Mark E, immediately start the timer (see Fig. 3 of Test Method D445).

A3.3.10 Measure the time required for the oil ring of contact to pass from the first timing Mark E to the second timing Mark F. As soon as the oil ring of contact reaches F, stop the timer (see Fig. 4 of Test Method D445).

A3.3.11 Finally, follow 11.6 of Test Method D445. Report the viscometer results individually and report the average.

A4. ENHANCED THERMAL GRAVIMETRIC ANALYSIS (TGA) PROCEDURE

A4.1 *Sample Preparation*—Either Procedure A or B should be used. For samples in this Test Method D5967, use Procedure B. Both procedures assume there is some empty space in the sample container.

A4.2 Procedure A

A4.2.1 Loosen the cap on sample container and place in a 93.3 °C water bath. (30 s for a 30 mL container, 60 s for 60 mL container, 120 s for a 120 mL container, and so forth.) The water level on the sample container should be slightly above the oil level.

A4.2.2 Remove the sample container from the water bath. Tighten the cap and shake the container for at least 30 s.

A4.2.3 Invert the sample container and shake for another 30 s.

A4.2.4 Invert the container to return it to an upright position. Carefully remove the cap, and with a clean, dry, stainless steel spatula, scrape the bottom of the container by dragging the tip. Withdraw the spatula to check for the presence of a thickened, viscous layer at the bottom of the container. If such a layer is present, reinsert the spatula and stir vigorously until the bottom sediment is completely mixed with the remainder of

the sample. When the spatula is withdrawn, the used oil clinging to it should have a uniform appearance and drain uniformly.

A4.2.5 Tighten cap.

A4.2.6 Shake vigorously for about 15 s.

A4.2.7 Invert the container and shake vigorously for 15 s.

A4.2.8 Reinvert the container and repeat A4.2.6 and A4.2.7.

A4.2.9 Portions of the sample can now be taken for analysis.

A4.3 Procedure B

A4.3.1 This procedure is based on a 120 mL sample size.

A4.3.2 Be sure cap is tight on sample container.

A4.3.3 Place sample on a commercial paint shaker.

A4.3.4 Shake for 5 min.

A4.3.5 Remove sample container from paint shaker.

A4.3.6 Portions of the sample can now be taken for analysis. No more than 2 min should pass between A4.3.4 and filling the TGA sample pan.

A4.4 TGA Procedure

A4.4.1 *Purge Flow Rate*— Use the setting recommended by the TGA instrument manufacturer.

Nitrogen – 99.99% minimum purity

Oxygen – 99.99% minimum purity

A4.4.2 *Sample Size*—Sample size is 20 mg.

A4.4.3 *Program Steps*— Initial Purge Gas—Nitrogen.

A4.4.3.1 Isothermal at 50 °C for 1 min,

A4.4.3.2 Heat to 550 °C at 100 °C/min,

A4.4.3.3 Isothermal at 550 °C for 1 min,

A4.4.3.4 Heat to 650 °C at 20 °C/min,

A4.4.3.5 Switch gas purge gas to oxygen, and

A4.4.3.6 Heat to 750 °C at 20 °C/min. The program is considered finished once a stable mass residue remains unchanged for 5 min or longer.

A4.5 Soot is the difference in the mass plateaus at purge gas change, approximately 650 °C, and after a stable mass residue is obtained around 750 °C. If the actual sample mass is reported, convert the difference to percent of the total. The soot value should be reported to the nearest 0.1 mass %.

A5. PROCUREMENT OF TEST MATERIALS

A5.1 Throughout the text, references are made to necessary hardware, reagents, materials, and apparatus. In many cases, for the sake of uniformity and ease of acquisition, certain suppliers are named. If substitutions are deemed appropriate for the specified suppliers, permission to substitute shall be obtained in writing from the TMC before such substitutions will be considered to be *equivalent*. The following entries of this annex represent a consolidated listing of the ordering information necessary to complete the references found in the text.

A5.2 Parts shown in [Table A5.1](#) are available from Mack

TABLE A5.1 New Parts for Each Rebuild

	Part Name	Mack Part No.	Quantity
(1)	Overhaul gasket sets	57GC2115A	2
		57GC2118A	1
		57GC2119	1
(2) ^A	Spin-on filters	485GB3191B	2
		Centrifugal filter cart	236GB244A
(3)	Engine coolant conditioner	25MF435B	1
(4)	Primary fuel filter	483GB444	1
(5)	Secondary fuel filter	483GB440	1
(6)	Valve guides	714GB222	24
(7)	Valve stems seals	446GC296	24

^A A P/N 57GC2120B Filter Kit contains items 2, 3, 4, and 5.

Trucks, Inc., 13302 Pennsylvania Ave., Hagerstown, MD 21742.

A5.3 Obtain injection pumps and the critical parts shown in [Table A5.2](#) from TEI, 12718 Cimarron Path, San Antonio, TX 78249-3423.

A5.4 *Slave Intercooler*—Use an intercooler suitable to meet test conditions prescribed in [Table 3](#).

A5.5 Solvent that meets the requirements of [7.4](#) is available from local petroleum product suppliers.

A5.6 Noncompounded oil ISO VG 32 (SAE 20) is available through many lubricant markets.

TABLE A5.2 Critical Parts for Each Rebuild

	Part Name	Mack Part No.	Quantity	
(1) ^A	Cylinder liners	509GC470	6	
(2)	Piston assembly	240GC2255M	6	
		Piston crown	240GC5113	6
		Piston skirt	240GC5119M	6
(3)	Piston ring set	353G2141	6	
		No. 1 Compression ring	349GC3107	6
		No. 2 Compression ring	349GC3108	6
		Oil ring	350GC343	6

^A A P/N 57GC3115 Cylinder Rebuild Kit contains items 1, 2, and 3. Six kits are required per engine rebuild.

A6. SAFETY PRECAUTIONS

A6.1 General Information

A6.1.1 The operating of engine tests can expose personnel and facilities to a number of safety hazards. It is recommended that only personnel who are thoroughly trained and experienced in engine testing should undertake the design, installation, and operation of engine test stands.

A6.1.2 Each laboratory conducting engine tests should have its test installation inspected and approved by its safety department. Personnel working on the engines should be provided with proper tools, be alert to common sense safety practices, and avoid contact with moving or hot engine parts, or both. Guards should be installed around all external moving or hot parts. When engines are operating at high speeds, heavy duty guards are required and personnel should be cautioned against working alongside the engine and coupling shaft. Barrier protection should be provided for personnel. All fuel lines, oil lines, and electrical wiring should be properly routed, guarded, and kept in good order. Scraped knuckles, minor burns, and cuts are common if proper safety precautions are not taken. Safety masks or glasses should always be worn by personnel working on the engines and no loose or flowing clothing, including long hair or other accessory to dress, which could become entangled, should be worn near running engines.

A6.1.3 The external parts of the engines and the floor area around the engines should be kept clean and free of oil and fuel spills. In addition, all working areas should be free of tripping hazards. Personnel should be alert for leaking fuel or exhaust gas. Leaking fuel represents a fire hazard and exhaust gas fumes are noxious. Containers of oil or fuel cannot be permitted to accumulate in the testing area.

A6.1.4 The test installation should be equipped with a fuel shut-off valve that is designed to automatically cut off the fuel supply to the engine when the engine is not running. A remote station for cutting off fuel from the test stand is recommended. Suitable interlocks should be provided so that the engine is automatically shutdown when any of the following events occur: engine or dynamometer water temperature becomes excessive; engine loses oil pressure; dynamometer loses field current; engine overspeeds; exhaust system fails; room ventilation fails; or the fire protection system is activated.

A6.1.5 Consider an excessive vibration pickup interlock if equipment operates unattended. Fixed fire protection equipment should be provided.

A6.1.6 Normal precautions should be observed whenever using flammable solvents for cleaning purposes. Make sure adequate fire fighting equipment is immediately accessible.

A7. DATA DICTIONARY

A7.1 The required data dictionary is available on the ASTM Test Monitoring Center Web Page at <http://www.astmtmc.cmu.edu/> or can be obtained in hard copy format from the TMC.

A8. T8-E EXTENDED LENGTH TEST REQUIREMENTS

A8.1 Calibration Test Acceptance (refer to 9.6)

A8.1.1 Use the TMC LTMS for calibration test targets and acceptance criteria.¹⁰

A8.1.2 The specified test parameters for determination of test acceptance are viscosity increase at 3.8 % TGA soot; relative viscosity at 4.8 % TGA soot, 50 % DIN Shear Loss; and relative viscosity at 4.8 % TGA soot, 100 % DIN Shear Loss.

A8.1.2.1 Calculate viscosity increase at 3.8 % TGA soot in accordance with 9.6.2.

A8.1.2.2 Calculate relative viscosity at 4.8 % TGA soot, 50 % DIN Shear Loss (RV48) as follows:

$$RV48 = 2 (VIS48)/(V_U + V_S) \quad (A8.1)$$

where:

VIS48 = viscosity at 4.8 % soot, as determined by linear interpolation,

V_U = kinematic viscosity of unsheared oil, by Test Method D445, at 100 °C, mm²/s, and

V_S = kinematic viscosity of sheared oil, by Test Method D445, at 100 °C, mm²/s. Use Test Method D6278 as the shearing method.

A8.1.2.3 *Correction Factor for Relative Viscosity at 4.8 % TGA Soot, 50 % DIN Shear Loss* For all tests completing on or after September 17, 2011, add +0.08 to the value calculated in A8.1.2.2.

A8.1.2.4 Calculate relative viscosity at 4.8 % TGA soot, 100 % DIN Shear Loss (RV2) as follows:

$$RV2 = (VIS48)/V_s \quad (A8.2)$$

where:

VIS48 = viscosity at 4.8 % soot, as determined by linear interpolation.

V_s = kinematic viscosity of sheared oil, by Test Method **D445** at 100 °C, mm²/s. Use Test Method **D6278** as the shearing method.

A8.1.2.5 Correction Factor for Relative Viscosity at 4.8 % TGA Soot, 100 % DIN Shear Loss For all tests completing on or after September 17, 2011, add +0.09 to the value calculated in **A8.1.2.4**.

A8.1.3 Soot Requirements:

A8.1.3.1 All operationally valid calibration tests on TMC oil 1004-2 shall produce a TGA soot level between 4.0 % and 4.8 % at 250 h and between 4.8 % and 5.8 % at 300 h.

A8.1.3.2 All operationally valid calibration tests on TMC oil 1004-3 completed on or before Dec. 31, 2006 shall produce a TGA soot level between 4.0 % to 4.8 % at 250 h and between 4.8 % and 5.8 % at 300 h.

A8.1.3.3 All operationally valid calibration tests on TMC oil 1004-3 completed on or after Jan. 1, 2007 and all operationally valid calibration tests on TMC oil 1005-2 shall produce a TGA soot level between 4.0 % to 5.0 % at 250 h and between 4.8 % and 5.8 % at 300 h.

A8.1.3.4 A lab may terminate a calibration test that is projected to miss either of these soot windows. Calibration tests that miss either of these soot windows are considered operationally invalid.

A8.2 Non-Reference Oil Test Requirements (refer to 9.8)

A8.2.1 Non-reference oil tests shall produce minimum TGA soot levels of 3.8 % at 250 h and 4.8 % at 300 h. Tests that do not meet the minimum soot levels are deemed not interpretable. Fixed non-reference oil pass criteria are published in Specification **D4485**.

A8.2.2 Non-Reference Oil Test Result Severity Adjustments (SA)—This test method incorporates the use of a SA for non-reference oil test results. A control chart technique, described in the LTMS, has been selected for the purpose of identifying when a bias becomes significant for viscosity increase at 3.8 % TGA soot and for both relative viscosities at 4.8 % TGA soot. When calibration test results identify a significant bias, a SA value is determined in accordance with the LTMS. Report the SA value (see **Annex A1**) under the non-reference oil test block in the space for SA. Add this SA value to non-reference oil test results, and enter the adjusted result in the appropriate space. The SA remains in effect until a new SA is determined from subsequent calibration tests, or the test results indicate the bias is no longer significant. SAs are calculated and applied on a laboratory basis.

A8.3 Procedure

A8.3.1 Test Cycle (refer to 10.4)—The test cycle includes a pretest oil flush at the conditions shown in **Table 2**. For new and rebuilt engines, a break-in procedure is required, also shown in **Table 2**. Conduct the test at 1800 r/min full-torque conditions for 300 h, as described in **Table A8.1**.

A8.4 Oil Inspection (refer to 11.1.1)—In addition to the oil analysis required in **11.1.1**, analyze the oil in accordance with Test Methods **D6278**.

A8.5 Precision and Bias (refer to Section 13)

A8.5.1 Precision—The test precision for viscosity increase at 3.8 % TGA soot, as of January 1, 1998, is shown in **Table 4**. The test precision for relative viscosity at 4.8 % TGA soot, as of January 1, 1998, is shown in **Table A8.2**.

A8.5.2 Bias—Bias is determined by applying an accepted statistical technique to reference oil test results, and when a significant bias is determined, a severity adjustment is permitted for non-reference oil test results (see **9.8.1** and **A8.2.2**).

TABLE A8.1 Test Conditions

Parameter	Limits
Time, h	300
Controlled Parameters ^A	
Speed, r/min	1800 ± 5
Fuel flow, kg/h	63.3 ± 1 %
Inlet manifold temperature, °C	43 ± 3
Coolant out, °C	85 ± 3
Fuel in, °C	40 ± 1
Intake air, °C	25 ± 3
Crankcase pressure, kPa	0.50 ± 0.25
Inlet air restriction, kPa	2.50 ± 0.25
Exhaust back pressure, kPa	3.1 ± 0.4
Uncontrolled Parameters	
Torque, N-m ^B	1369-1398 ^C
Exhaust temperature, °C	
Pre-turbine	602-632
Tailpipe	455-474
Inlet manifold pressure, kPa	186-199 ^C
Oil, °C	100-107
Main gallery oil pressure, kPa	372-441 ^D
Intercooler ΔP, kPa	Not to exceed 13.6
Oil filter ΔP, kPa	Not to exceed 138 ^E

^A Hold all control parameters at the mean indicated.

^B At 98.2 kPa and 29.5 °C dry air.

^C Take corrective action when engine performance falls outside these limits. Fuel flow is the primary control parameter.

^D Note pressures are typical of SAE 15W40 oils; other oil grades may show different results.

^E Change the two full flow filters if oil filter ΔP exceeds 138 kPa.

TABLE A8.2 T-8E Precision Data

Parameter	Intermediate Precision	Reproducibility
	(i.p.)	(R)
Relative viscosity at 4.8 % TGA soot, 50 % Shear loss	0.65	0.69
Relative viscosity at 4.8 % TGA soot, 100 % Shear loss	0.69	0.73

A9. T8-A ABBREVIATED LENGTH TEST REQUIREMENTS

A9.1 Calibration Test Acceptance (refer to 9.6)

A9.1.1 Calibration status for the T8-A is determined by successfully calibrating a test stand in accordance with the T-8 requirements listed in 9.6. In other words, a stand that is calibrated for T-8 testing is automatically calibrated for T-8A testing.

A9.1.1.1 A maximum of 600 h of T-8A non-reference test time is permitted without counting against the 3000 h calibration period in 9.5.1. Declare such tests solely as T-8A tests prior to test start and shall not exceed 150 h in length. If a test fails to meet either condition, then the entire test length shall count against the 3000 h limit in 9.5.1. It is the responsibility of the test laboratory to maintain sufficient documentation to demonstrate the intent of running solely a T-8A test. T-8 and T-8E test starts count against the 3000 h calibration period of 9.5.1.

A9.2 Non-Reference Oil Test Requirements (refer to 9.8)

A9.2.1 The specified test parameter for the T-8A is average rate of kinematic viscosity increase from (100 to 150) h (Viscosity Slope₁₀₀₋₁₅₀).

A9.2.2 Viscosity Slope₁₀₀₋₁₅₀ is calculated as follows:

$$\text{Viscosity Slope}_{100-150} = (VIS_{150} - VIS_{100})/50 \quad (\text{A9.1})$$

where:

VIS_{150} = kinematic viscosity (mm²/s) at 150 h, determined in accordance with Annex A3, and
 VIS_{100} = kinematic viscosity (mm²/s) at 100 h, determined in accordance with Annex A3.

A9.3 Procedure

A9.3.1 *Test Cycle (refer to 10.4)*—With the exception of test length, conduct the test in accordance with **Table 3**. Non-reference oil test length is 150 h minimum.

A9.4 Precision and Bias (refer to Section 13)

A9.4.1 *Precision*—The test precision for Viscosity Slope₁₀₀₋₁₅₀, as of September 1, 1998, is shown in **Table A9.1**.

TABLE A9.1 T-8A Precision Data

Parameter	Repeatability (r)	Reproducibility (R)
Viscosity Slope ₁₀₀₋₁₅₀	0.023	0.024

A9.4.2 *Bias*—No estimate of bias is currently available.

SUMMARY OF CHANGES

Subcommittee D02.B0 has identified the location of selected changes to this standard since the last issue (D5967 – 15a) that may impact the use of this standard. (Approved May 1, 2017.)

(1) Subsection **7.2**, revised to clarify that fuel is from a sole supply source.

ASTM International takes no position respecting the validity of any patent rights asserted in connection with any item mentioned in this standard. Users of this standard are expressly advised that determination of the validity of any such patent rights, and the risk of infringement of such rights, are entirely their own responsibility.

This standard is subject to revision at any time by the responsible technical committee and must be reviewed every five years and if not revised, either reapproved or withdrawn. Your comments are invited either for revision of this standard or for additional standards and should be addressed to ASTM International Headquarters. Your comments will receive careful consideration at a meeting of the responsible technical committee, which you may attend. If you feel that your comments have not received a fair hearing you should make your views known to the ASTM Committee on Standards, at the address shown below.

This standard is copyrighted by ASTM International, 100 Barr Harbor Drive, PO Box C700, West Conshohocken, PA 19428-2959, United States. Individual reprints (single or multiple copies) of this standard may be obtained by contacting ASTM at the above address or at 610-832-9585 (phone), 610-832-9555 (fax), or service@astm.org (e-mail); or through the ASTM website (www.astm.org). Permission rights to photocopy the standard may also be secured from the Copyright Clearance Center, 222 Rosewood Drive, Danvers, MA 01923, Tel: (978) 646-2600; http://www.copyright.com/