



Standard Test Method for Determination of Non-methane Organic Compounds (NMOC) in Ambient Air Using Cryogenic Preconcentration and Direct Flame Ionization Detection¹

This standard is issued under the fixed designation D5953M; the number immediately following the designation indicates the year of original adoption or, in the case of revision, the year of last revision. A number in parentheses indicates the year of last reapproval. A superscript epsilon (ϵ) indicates an editorial change since the last revision or reapproval.

1. Scope

1.1 This test method² presents a procedure for sampling and determination of non-methane organic compounds (NMOC) in ambient, indoor, or workplace atmospheres.

1.2 This test method describes the collection of integrated whole air samples in silanized or other passivated stainless steel canisters, and their subsequent laboratory analysis.

1.2.1 This test method describes a procedure for sampling in canisters at final pressures above atmospheric pressure (pressurized sampling).

1.3 This test method employs a cryogenic trapping procedure for concentration of the NMOC prior to analysis.

1.4 This test method describes the determination of the NMOC by the flame ionization detection (FID), without the use of gas chromatographic columns and other procedures necessary for species separation.

1.5 The range of this test method is from 20 to 10 000 ppb C (**1, 2**).³

1.6 This test method has a larger uncertainty for some halogenated or oxygenated hydrocarbons than for simple hydrocarbons or aromatic compounds. This is especially true if there are high concentrations of chlorocarbons or chlorofluorocarbons present.

1.7 The values stated in SI units are to be regarded as standard. The values given in parentheses are mathematical

¹ This is under the jurisdiction of ASTM Committee D22 on Air Quality and is the direct responsibility of Subcommittee D22.03 on Ambient Atmospheres and Source Emissions.

Current edition approved Oct. 1, 2016. Published October 2016. Originally approved in 1996. Last previous edition approved in 2009 as D5953M – 96 (2009). DOI: 10.1520/D5953M-16.

² This test method is based on EPA Compendium Method TO-12: "Determination of Non-Methane Organic Compounds (NMOC) in Ambient Air Using Cryogenic Pre-Concentration and Direct Flame Ionization Detection (PDFID)," *Compendium of Methods for the Determination of Toxic Organic Compounds in Ambient Air*, EPA 600/4-89-017, U.S. Environmental Protection Agency, Research Triangle Park, NC, March 1990.

³ The boldface numbers in parentheses refer to the list of references at the end of this standard.

conversions to inch-pound units that are provided for information only and are not considered standard.

1.8 *This standard does not purport to address all of the safety concerns, if any, associated with its use. It is the responsibility of the user of this standard to establish appropriate safety and health practices and determine the applicability of regulatory limitations prior to use.*

2. Referenced Documents

2.1 ASTM Standards:⁴

D1193 Specification for Reagent Water

D1356 Terminology Relating to Sampling and Analysis of Atmospheres

D1357 Practice for Planning the Sampling of the Ambient Atmosphere

D5466 Test Method for Determination of Volatile Organic Compounds in Atmospheres (Canister Sampling Methodology)

2.2 Other References:

EPA Method TO-12 Determination of Non-Methane Organic Compounds (NMOC) in Ambient Air Using Cryogenic Pre-Concentration and Direct Flame Ionization Detection (PDFID)⁵

3. Terminology

3.1 *Definitions*—For definitions of terms used in this test method, refer to Terminology D1356.

3.2 Definitions of Terms Specific to This Standard:

3.2.1 *cryogen*—a refrigerant used to obtain very low temperatures in analytical system cryogenic traps.

3.2.1.1 *Discussion*—Liquid argon (bp -185.7°C at standard pressure) is recommended and may be required for use in some applications of this test method. Cryogens with lower boiling

⁴ For referenced ASTM standards, visit the ASTM website, www.astm.org, or contact ASTM Customer Service at service@astm.org. For *Annual Book of ASTM Standards* volume information, refer to the standard's Document Summary page on the ASTM website.

⁵ Available from United States Environmental Protection Agency (EPA), William Jefferson Clinton Bldg., 1200 Pennsylvania Ave., NW, Washington, DC 20460, <http://www.epa.gov>.

points, such as liquid nitrogen, may be used if the cryogenic trap temperature is actively maintained at -185°C to avoid the potential for trapping oxygen or methane from air samples.

3.2.2 *dynamic calibration*—calibration of an analytical system with pollutant concentrations that are generated in a dynamic, flowing system, such as by quantitative, flow-rate dilution of a high-concentration gas standard with zero gas.

3.2.3 *NMOC*—non-methane organic compounds.

3.2.3.1 *Discussion*—Total non-methane organic compounds are compounds, excluding methane, measured using a flame ionization detector (FID), with vapor pressures above 10^{-2} kPa recovered from canisters.

3.2.4 *ppm C and ppb C*—concentration units of parts-per-million and parts-per-billion of organic carbon as detected by FID.

3.2.4.1 *Discussion*—For example, when calibrating with propane, concentrations of NMOC in samples are equivalent to parts-per-million by volume (ppm (v)) or parts-per-billion by volume (ppb (v)) multiplied by the number of carbon atoms in propane, which is three (3).

4. Summary of Test Method (2-6)

4.1 An air sample is collected directly from ambient air, using a pre-cleaned sample evacuated passivated canister, which is then transported to a laboratory.

4.2 A fixed-volume portion of the sample air is drawn from the canister at a low flow rate through a silanized glass-bead filled trap that is cooled to approximately -186°C with liquid argon. The cryogenic trap simultaneously collects and concentrates the NMOC using condensation, while allowing the nitrogen, oxygen, methane, and other compounds with boiling points below -186°C to pass through the trap without retention. The system is dynamically calibrated so that the volume of sample passing through the trap does not have to be quantitatively measured, but must be precisely repeatable between the calibration and the analytical phases.

4.3 After the fixed-volume air sample has been drawn through the trap, a helium carrier gas flow is diverted to pass through the trap, in the opposite direction to the sample flow, and into an FID. When the residual air and methane have been flushed from the trap and the FID baseline restabilizes, the cryogen is removed and the temperature of the trap is raised to 90°C at 30°C per minute.

4.4 The organic compounds previously collected on the trap re-volatilize and are carried into the FID, resulting in a response peak or peaks from the FID. The area of the peak or peaks is integrated, and the integrated value is translated to concentration units using a previously obtained calibration curve relating integrated peak areas with known concentrations of propane or other calibrant.

4.5 The cryogenic trap simultaneously concentrates the NMOC while separating and removing the methane from samples. The technique thus directly measures NMOC with greater sensitivity than conventional continuous NMOC analyzers due to the pre-concentration procedure.

4.6 The sample is injected into the hydrogen-rich flame of an FID, where the organic vapors burn, producing ionized molecular fragments. The resulting ion fragments are then collected and detected. Because this test method employs a helium carrier gas, the detector response is nearly identical for many hydrocarbon compounds commonly of interest. Thus, the historical short-coming of varying FID response to aromatic, olefinic, and paraffinic hydrocarbons is minimized. Users are cautioned that the FID is much less sensitive to most organic compounds containing functional groups such as carbonyls, alcohols, halocarbons, etc. than simple hydrocarbons.

5. Significance and Use

5.1 Many regulators, industrial processes, and other stakeholders require determination of NMOC in atmospheres.

5.2 Accurate measurements of ambient NMOC concentrations are critical in devising air pollution control strategies and in assessing control effectiveness because NMOCs are primary precursors of atmospheric ozone and other oxidants (7, 8).

5.2.1 The NMOC concentrations typically found at urban sites may range up to 1 to 3 ppm C or higher. In order to determine transport of precursors into an area monitoring site, measurement of NMOC upwind of the site may be necessary. Rural NMOC concentrations originating from areas free from NMOC sources are likely to be less than a few tenths of 1 ppm C.

5.3 Conventional test methods based upon gas chromatography and qualitative and quantitative species evaluation are relatively time consuming, sometimes difficult and expensive in staff time and resources, and are not needed when only a measurement of NMOC is desired. The test method described requires only a simple, cryogenic pre-concentration procedure followed by direct detection with an FID. This test method provides a sensitive and accurate measurement of ambient total NMOC concentrations where speciated data are not required. Typical uses of this standard test method are as follows.

5.4 An application of the test method is the monitoring of the cleanliness of canisters.

5.5 Another use of the test method is the screening of canister samples prior to analysis.

5.6 Collection of ambient air samples in pressurized canisters provides the following advantages:

5.6.1 Convenient collection of integrated ambient samples over a specific time period,

5.6.2 Capability of remote sampling with subsequent central laboratory analysis,

5.6.3 Ability to ship and store samples, if necessary,

5.6.4 Unattended sample collection,

5.6.5 Analysis of samples from multiple sites with one analytical system,

5.6.6 Collection of replicate samples for assessment of measurement precision, and

5.6.7 Specific hydrocarbon analysis can be performed with the same sample system.

6. Interferences

6.1 In laboratory evaluations, moisture in the sample has been found to cause a positive shift in the FID baseline. The effect of this shift is minimized by carefully selecting the integration beginning and termination points and adjusting the baseline used for calculating the area of the NMOC peaks.

6.2 With helium as a carrier gas, FID response is uniform for most hydrocarbon compounds, but the response can vary considerably for other types of organic compounds such as halogenated and oxygenated compounds.

7. Apparatus

7.1 *Sample Collection System*, (Fig. 1).

7.1.1 *Sample Canister(s)*, stainless steel, stainless steel electropolished passivated Summa⁶-polished or silanized vessel(s) of 4 to 6 L capacity, used for automatic collection of integrated air samples.

7.1.1.1 Mark each canister with a unique identification number.

7.1.2 *Sample Pump*, stainless steel, metal bellows type.

7.1.2.1 Ensure that the pump is free of leaks, and uncontaminated by oil or organic compounds.

7.1.2.2 Shock mount the pump to minimize vibration.

7.1.3 *Pressure Gauge*, 0 to 210 kPa (0 to 30 psig).

7.1.4 *Solenoid Valve*, controls the sample flow to the canister with negligible temperature rise.

7.1.5 *Flow Control Device*, mass flow controller, micro-metering valve, or critical orifice, to maintain the sample flow over the sampling period.

7.1.6 *Particulate Matter Filter*, inert in-line filter, 2 μm or less, or other suitable filter, used to filter the air sample.

7.1.7 *Auxiliary Vacuum Pump or Blower*, draws sample air through the sample inlet line to reduce inlet residence time to no greater than 10 s.

7.1.7.1 Shock mount the pump to minimize vibration.

7.1.8 *Timer*, programmable, and electrically connected to the solenoid valve (7.1.4) and pumps (7.1.2 and 7.1.7), capable of controlling the pumps and the solenoid valve.

7.1.9 *Sample Inlet Line*, transports the sample air into the sample system, consisting of stainless steel tubing components.

7.2 *Sample Canister Cleaning System* (Fig. 2).

7.2.1 *Vacuum Pump*, capable of evacuating sample canister(s) to an absolute pressure of ≤ 1.69 kPa (29.5 in. Hg).

7.2.2 *Manifold*, stainless steel manifold with connections for simultaneously cleaning several canisters.

7.2.3 *Shut-off Valve(s)*, nine required.

7.2.4 *Pressure Gauge*, 0 to 350 kPa (0 to 50 psig)—monitors zero-air pressure.

7.2.5 *Cryogenic Trap* (2 required), U-shaped open tubular trap cooled with liquid argon, used to prevent contamination from back diffusion of oil from vacuum pump, and providing clean, zero-air to the sample canister(s).

7.2.6 *Vacuum Gauge*, capable of measuring vacuum in the manifold to an absolute pressure of 1.69 kPa (29.5 in. Hg vacuum) or less, with scale divisions of 0.07 kPa (0.5 μm Hg).

7.2.7 *Flow Control Valve*, regulates flow of zero-air into the canister(s).

7.2.8 *Humidifier*, water bubbler or other system capable of providing moisture to the zero-air supply.

7.2.9 *Isothermal Oven*, for heating canisters, not shown in Fig. 2.

7.3 *Analytical System* (Fig. 3).

7.3.1 *FID System*, includes flow controls for the FID fuel and combustion air, temperature control for the FID, and signal processing electronics. Set the FID combustion air, hydrogen, and helium carrier flow rates according to the manufacturer's instructions.

7.3.2 *Data Reduction Device*, such as a computer, equipped with data acquisition hardware and software and a laser printer, or an electronic integrator, with chart recorder, capable of integrating the area of one or more FID response peaks and calculating peak area corrected for baseline drift.

7.3.2.1 If a discrete integrator and chart recorder are used, exercise care to ensure that these components do not interfere with each other electrically or electronically.

7.3.2.2 Range selector controls on both the integrator and the FID analyzer may not provide accurate range ratios, so prepare individual calibration curves for each range.

7.3.2.3 The integrator must be capable of marking the beginning and ending of peaks, constructing the appropriate baseline between the start and end of the integration period, and calculating the peak area.

7.3.3 *Cryogenic Trap*, constructed from a single piece of chromatographic-grade stainless steel tubing (3 mm outside diameter, 2 mm inside diameter), as shown in Fig. 4.

7.3.3.1 Pack the central portion of the trap (70 to 100 mm) with silanized 180 to 250 μm (60/80 mesh) glass beads, with small silanized glass wool plugs, to retain the beads.

7.3.3.2 The arms of the trap must be of such length to permit the beaded portion of the trap to be submerged below the level of cryogen in the Dewar flask.

⁶ The Summa process is a trademark of Moleetrics, Inc., 4000 E. 89th St., Cleveland, OH 44105.

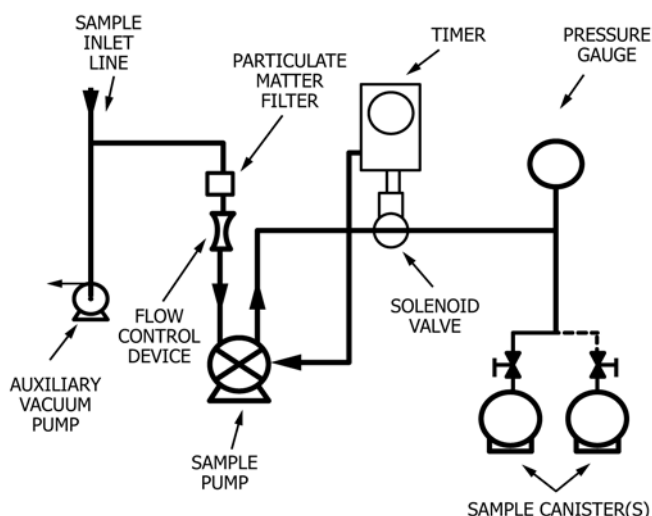
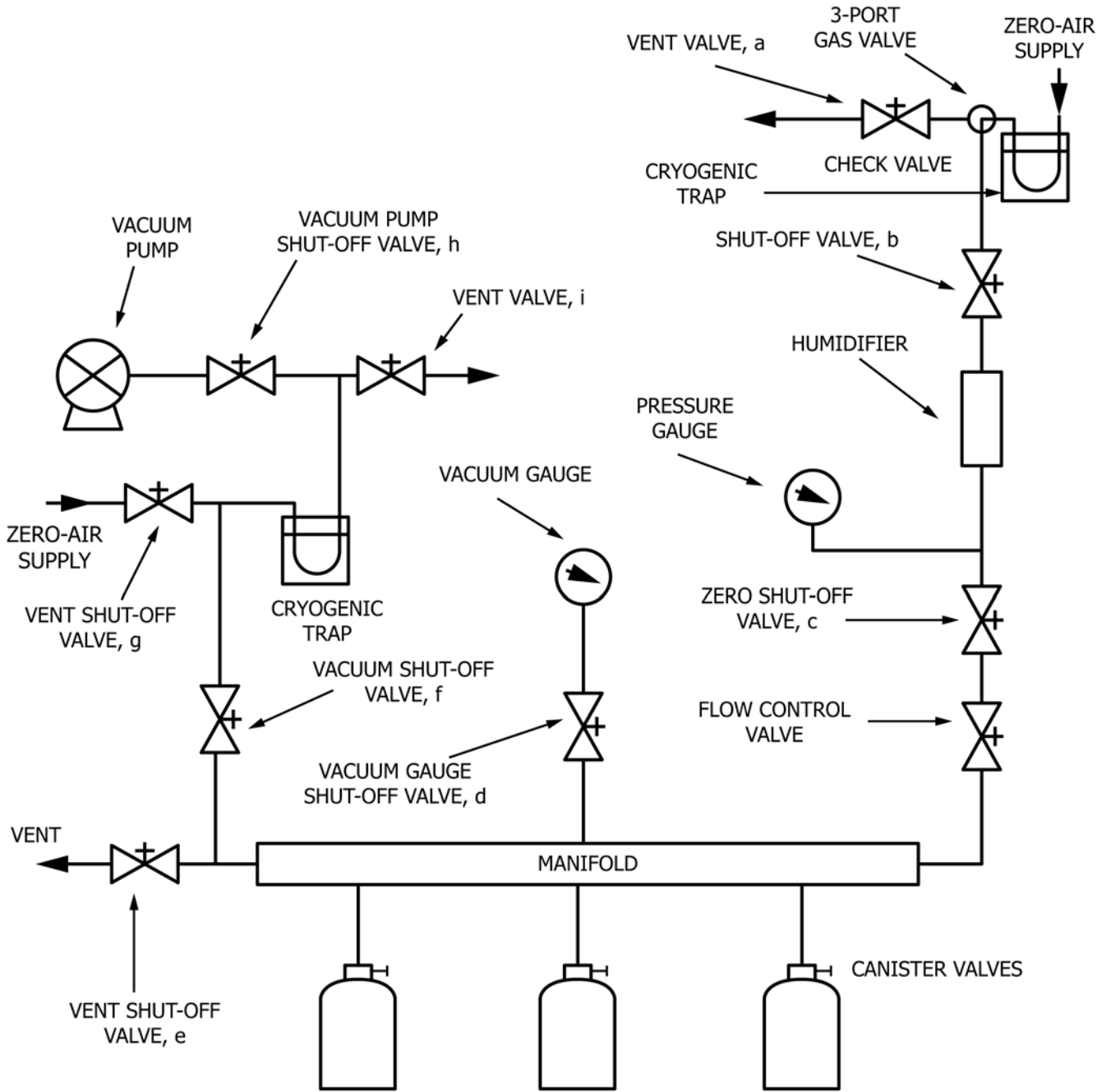

FIG. 1 Sample System for Automatic Collection of Integrated Air Samples



SAMPLE CANISTERS
 FIG. 2 Canister Cleaning System

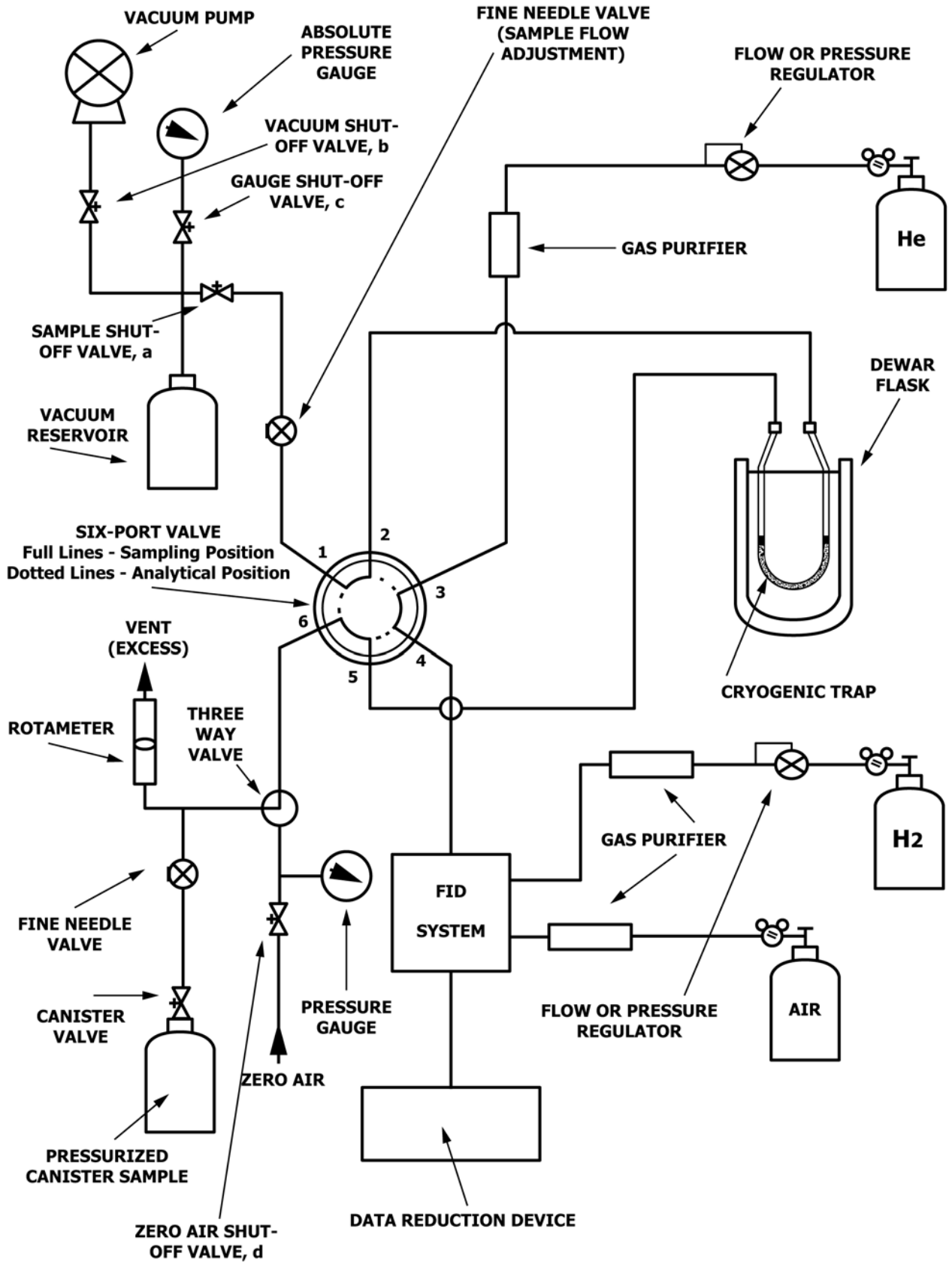

FIG. 3 NMOc Analytical System

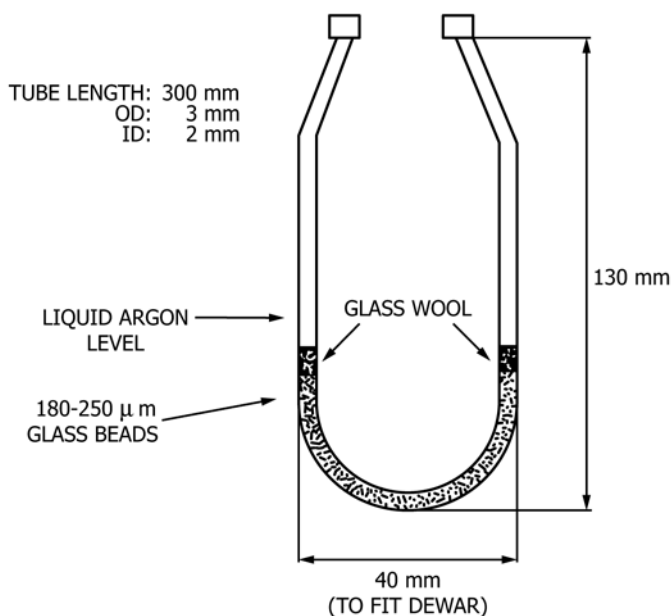

FIG. 4 Cryogenic Sample Trap

7.3.3.3 Connect the trap directly to the six-port valve (7.3.4) to minimize the line length between the trap (7.3.3) and the FID (7.3.1).

7.3.3.4 Mount the trap to allow clearance so the Dewar flask may be applied and withdrawn to facilitate cooling and heating of the trap (see 7.3.12).

7.3.4 *Six-Port Valve*—Locate the six-port valve and as much of the interconnecting tubing as practical inside an oven or otherwise heat it to 90°C to minimize wall losses or adsorption/desorption in the connecting tubing. All lines must be as short as practical.

NOTE 1—A diaphragm type valve is recommended for use, as standard rotational valves do not typically perform well in many applications of this test method.

7.3.5 *Multistage Pressure Regulators* (3 required), standard two-stage, stainless steel diaphragm regulators with pressure gauges, for helium, air, and hydrogen cylinders.

7.3.6 *Auxiliary Flow or Pressure Regulators* (2 required), to maintain constant flow rates, within 1 mL/min for the helium carrier and the hydrogen.

7.3.7 *Fine Needle Valve* (2 required)—One adjusts the sample flow rate through the trap, and the other adjusts the sample flow rate from the canister.

7.3.8 *Dewar Flask*, holds cryogen used to cool the trap, sized to contain the submerged portion of the trap.

7.3.9 *Absolute Pressure Gauge*, 0 to 60 kPa (0 to 450 mm Hg), with scale divisions of 0.25 kPa (2 mm Hg), monitors repeatable volumes of sample air through the cryogenic trap.

7.3.10 *Vacuum Reservoir*; 1 to 2 L capacity, typically 1 L.

7.3.11 *Gas Purifiers* (3 required), gas scrubbers containing Drierite or silica gel and 5A molecular sieve to remove moisture and organic impurities in the helium, air, and hydrogen gas flows.

NOTE 2—Check the purity of the gas purifiers prior to use by passing zero-air through them and analyzing the gas in accordance with 11.4. The gas purifiers are clean if the NMOC concentration of the emitted gas is

below the detection limit of the test method.

7.3.12 *Trap Heating System*, chromatographic oven, direct induction load heater, or other means to heat the trap to 90°C at a controlled rate of 30°C per minute.

7.3.12.1 Repeatable types of heat sources are recommended, including a temperature-programmed chromatograph oven, electrical heating of the trap itself, or any type of heater that brings the temperature of the trap up to 90°C in 1 to 2 min. This is not shown in Fig. 3.

7.3.13 *Toggle Shut-Off Valves* (4 required), must be leak free. Two are positioned on each side of the vacuum reservoir (7.3.10), one at the absolute pressure gauge (7.3.9), and one at the zero air cylinder (8.5) used for the analytical system leak test (10.1).

7.3.14 *Vacuum Pump*, general purpose laboratory oil-less diaphragm pump, must be capable of evacuating the vacuum reservoir (7.3.10) to allow the desired sample volume to be drawn through the trap.

7.3.15 *Vent*, to keep the trap at atmospheric pressure during trapping.

7.3.16 *Rotameter or Electronic Flow Measurement Device*, verifies that there is vent flow at all times during trapping.

7.3.17 *Three-Way Valve*.

7.3.18 *Chromatographic-Grade Stainless Steel Tubing and Fittings*, stainless steel tubing and fittings for interconnections.

7.3.18.1 All such materials in contact with the sample, analyte, or support gases prior to analysis must be of stainless steel or other inert metal.

7.3.18.2 Do not use plastic or TFE-fluorocarbon tubing or fittings.

7.3.19 *Pressure Gauge*, capable of reading up to 500 kPa (60 psig).

8. Reagents and Materials

8.1 **Warning**—Gas cylinders and compressed gas standards should only be handled in well-ventilated locations, away from sparks and flames. Improper handling of compressed gas cylinders containing air, nitrogen, hydrogen, or helium can result in explosion. Rapid release of nitrogen or helium can result in asphyxiation. Compressed air supports combustion. Hydrogen is highly flammable and burns with a colorless, transparent flame. Liquid argon is a freeze hazard as well as an asphyxiate.

8.2 *Gas Cylinders of Helium and Hydrogen*, ultrahigh purity grade.

8.3 *Combustion Air*, cylinder containing less than 0.02 ppm (v) hydrocarbons, or equivalent air source.

8.4 *Propane Calibration Standard*, cylinder containing 1 to 100 ppm (v) (3 to 300 ppm C) propane in air, traceable to a National Institute of Standards and Technology (NIST) Standard Reference Material (SRM) or to a NIST/EPA-approved Certified Reference Material (CRM).

8.5 *Zero-Air*, cylinder containing less than or equal amounts of total hydrocarbons as the detection limit of the test method.

8.5.1 Zero-air may be obtained from a cylinder of zero-grade compressed air scrubbed with anhydrous calcium sulfate

or silica gel and 5A molecular sieve or activated charcoal, or by catalytic cleanup of ambient air.

8.5.2 Pass the zero-air used for canister cleaning (9.3) through a cryogenic cold trap (7.2.5) for final cleanup, then through a hydrocarbon-free water (8.7) humidifier (7.2.8) (or other device).

8.6 Cryogen (bp -185.7°C), liquid argon recommended.

8.6.1 If liquid argon cannot maintain the trap temperature at -185.7°C due to the location of the laboratory, such as at high altitudes (where the normal atmospheric pressure is less than 101.3 kPa), a mechanical refrigeration system can be used (see 13.5.1).

8.7 Purity of Water—Unless otherwise stated, water shall be Type II reagent water conforming to Specification D1193.

9. Canister Cleanup and Preparation

9.1 Leak test and clean the canisters (7.1.1) of contaminants before sample collection.

9.2 Leak test the canisters by pressurizing them to approximately 200 kPa above atmospheric pressure (30 psig) with zero-air (8.5), using the canister cleaning system (see Fig. 2).

9.2.1 Record the final pressure and close the canister valve, then check the pressure after 24 h. If leak-tight, the pressure will not have not dropped by more than 15 kPa (2 psig) over the 24-h period at constant temperature.

9.2.2 Record the leak check result on the Sampling Data Sheet, Fig. 5.

9.3 Clean the canister(s) as illustrated in Fig. 2.

9.3.1 Close all the valves.

9.3.2 Add cryogen (8.6) to both the vacuum pump and zero-air supply traps (7.2.5).

9.3.3 Connect the canister(s) (7.1.1) to the manifold (7.2.2). Open the vent shut-off valve (E) and the canister valve(s) to release any remaining pressure in the canister(s).

9.3.4 Now close the vent shut-off valve (E) and open the vacuum shut-off valve (D).

9.3.5 Energize the vacuum pump (7.2.1), open the vacuum shut-off valves F and H, and evacuate the canister(s) to ≤1.69 kPa (29.5 in. Hg vacuum) for 30 minutes with optional heating to no more than 100°C in an isothermal oven (7.2.9).

9.4 On a daily basis, or more often if necessary, blow out the cryogenic traps (7.2.5) with zero-air (8.5), using valves A and I, to remove trapped water from previous canister cleaning cycles.

9.5 Close the vacuum and vacuum gauge shut-off valves (H and D) and open the zero-air shut-off valves (B and C) to pressurize the canister(s) with moist zero-air (8.5) to approximately 200 kPa over atmospheric pressure (30 psig). Hold this pressure for 30 minutes. If a zero gas generator system is used, limit the flow rate to maintain the zero-air quality.

9.6 Close the zero-air shut-off valve (C) and allow the canister(s) to vent down to atmospheric pressure through the vent shut-off valve (E).

9.6.1 Close the vent shut-off valve (E).

PRESSURIZED CANISTER SAMPLING DATA SHEET

GENERAL INFORMATION

PROJECT _____
 SITE _____
 LOCATION _____
 MONITOR STATION NO. _____
 PUMP SERIAL NO. _____

OPERATOR _____
 ORIFICE NO. _____
 FLOW RATE _____
 CALIBRATED BY _____
 LEAK CHECK _____
Pass Fail

FIELD DATA

Date	Canister No.	Sample No.	Sample Time		Average Atmospheric Conditions			Canister Pressure			Comments
			Start	Stop	Temperature, °C	Pressure, kPa	RH, %	Initial, kPa	Final, kPa	Lab, kPa	

Date

Signature

Title

Title

FIG. 5 Example Sampling Data Sheet

9.7 As a *blank check* of the canister(s) and cleanup procedure, initially analyze the zero-air content of each canister until the cleanup system and canisters are proven to reliably result in blank tests of NMOC less than the MDL.

9.7.1 Repeat the last three steps three times, or until the blank is less than the detection limit of the procedure.

9.7.2 Do not use any canister that does not test at below the MDL.

9.8 Re-evacuate the canisters to ≤ 1.69 kPa (29.5 in. Hg vacuum), using the canister cleaning system.

9.8.1 Close the canister valve(s), remove the canister(s) from the canister cleaning system, and cap the canister connections with stainless steel or brass fittings.

9.8.2 The canisters are now ready for the collection of air samples. Attach identification tags to the neck of each canister for field notes and chain-of-custody purposes.

9.8.3 Record the canister pressure as *initial* on the Sampling Data Sheet (see Fig. 5).

9.9 Leak test the sample system and the outlet side of the sample pump (7.1.2) prior to field use by attaching a vacuum gauge (7.2.6) to the canister inlet using a connecting tubing with a tee fitting, capping the pump inlet, and evacuating to approximately 15 Pa (0.1 mm Hg). If the pressure remains at ± 0.4 Pa (3 μ m Hg) for 15 min, with the pump energized, the pump and connecting lines are leak free.

10. Sampling

10.1 General:

10.1.1 See Practice D1357 for general sampling procedures.

10.1.2 Choose a flow control device (7.1.5) to provide a constant flow rate such that the canister is pressurized to approximately 200 kPa (one atmosphere above ambient pressure), over the desired sampling period (see 10.2).

10.1.3 Use a second canister when a duplicate sample is desired for quality assurance (QA) purposes (see 12.3.4).

10.1.4 Exercise care in selecting, cleaning, and handling the sample canisters and sampling apparatus to avoid losses or contamination of the samples.

10.2 Sample Collection:

10.2.1 Assemble the sampling apparatus as shown in Fig. 1, with the connecting lines between the sample pump (7.1.2) and the canisters (7.1.1) as short as possible to minimize their volume.

10.2.1.1 Purge the sample inlet line (7.1.9) with a flow of several L/min, using a small auxiliary vacuum pump (7.1.7), to minimize the sample residence time.

10.2.2 Determine the flow rate required to pressurize the canisters to approximately 200 kPa (one atmosphere above ambient pressure or 2 atmospheres absolute pressure) during the desired sample period, utilizing the following equation:

$$F = \frac{P V n}{t} \quad (1)$$

where:

- F = flow rate, mL/min,
- P = canister final absolute pressure ratio,
= $(P_a + P_g)/P_a$,

V = volume of the canister, mL,

n = number of canisters connected together (for simultaneous sample collection),

t = sample period, min,

P_g = pressure in canister, kPa above atmospheric pressure, (psig), and

P_a = standard atmospheric pressure, 101.3 kPa (14.7 psig).

10.2.2.1 As an example, if one 6-L canister is to be filled to approximately 100 kPa above atmospheric pressure in 3 h, the flow rate would be calculated as follows:

$$P = \frac{100 + 101.3}{101.3} = 1.987 \quad (2)$$

$$F = \frac{1.987 \times 6000 \times 1}{180} = 66 \text{ mL/min}$$

10.2.3 Adjust the flow control device (7.1.5) suitable for maintaining a constant flow at the calculated flow rate into the canister over the desired sampling period. This will maintain an approximately constant flow up to a canister pressure of about 200 kPa (30 psig), after which the flow drops with increasing pressure. At 101.3 kPa above atmospheric pressure (14.7 psig), the flow will be about 10 % below the initial flow, depending upon pump performance.

10.2.4 Place a particulate matter filter (7.1.6) in front of the flow control device (7.1.5).

10.2.5 Check the sampling system for contamination by filling two evacuated, cleaned canisters (see 10.2) with humidified zero-air (8.5) through the sampling system. Analyze the canisters in accordance with 11.4. The sampling system is free of contamination if the canisters contain less than the detection limit of the system.

10.2.6 Observe the flow rate into the sampling system during the system contamination. Check to ensure that sample flow rate remains relatively constant (± 10 %) up to about 100 kPa above atmospheric pressure.

NOTE 3—A drop in the flow rate may occur near the end of the sampling period as the canister pressure approaches its final pressure, depending upon pump performance.

10.2.7 Reassemble the sampling system.

10.2.8 Verify that the timer (7.1.8), pumps (7.1.2 and 7.1.7) and solenoid valve (7.1.4) are connected and operating properly.

10.2.9 Verify that the timer (7.1.8) is correctly set for the desired sample period, and that the solenoid valve (7.1.4) is closed.

10.2.10 Connect the cleaned, evacuated canister(s) (9.8) to the non-contaminated sampling system, by way of the solenoid valve (7.1.4), for sample collection.

10.2.11 Verify that the solenoid valve (7.1.4) is closed. Open the canister valve(s). Temporarily connect a small rotameter (7.3.16) to the sample inlet (7.1.9) to verify that there is no flow.

NOTE 4—Flow detection would indicate a leaking (or open) solenoid valve or an untightened fitting connection.

10.2.11.1 Remove the rotameter (7.3.16) after the leak detection procedure.

10.2.12 Record the necessary information on the Sampling Data Sheet (see Fig. 5).

10.2.13 Program the automatic timer (7.1.8) to activate and stop the pump or pumps (7.1.2 and 7.1.7) and to open and close the solenoid valve (7.1.4) at the appropriate time for the selected sample period. Sampling will automatically commence at the programmed time.

10.2.14 At the end of the sample period, close the canister valve(s) and disconnect the canister(s) from the sampling system.

10.2.15 If canisters are not constructed with pressure gauges, connect a pressure gauge (7.1.3) to each canister and briefly open and close the canister valve(s).

10.2.16 Record the final canister pressure on the Sampling Data Sheet (see Fig. 5). Note that the canister pressure should be approximately 100 kPa above atmospheric pressure.

NOTE 5—If the canister pressure is not approximately 100 kPa above atmospheric pressure, attempt to determine and correct the cause before obtaining the next sample. Re-cap the canister valve.

10.2.17 Complete the necessary information on the identification tag on the sample canister(s) and on the Field Data Sheet.

10.2.17.1 Note on the sampling data sheet any atmospheric conditions or special activities in the area, (such as rain, smoke, construction, plowing, etc.) that may affect the sample contents.

10.2.18 Return the canister(s) to the laboratory for sample analysis.

11. Sample Analysis

11.1 Assemble (see Fig. 3) the analytical system.

11.2 *Analytical System Leak Check*—Perform an analytical system leak-check procedure during the system qualification/checkout, before a series of analyses, or if leaks are suspected. Include this step in the laboratory's Standard Operating Procedure (SOP) (see 12.1).

11.2.1 Leak check the analytical system by placing the six-port valve (7.3.4) in the trapping position, closing the absolute pressure gauge (7.3.9) toggle shut-off valve (C), and placing the 3-way valve in the zero-air position.

11.2.1.1 Open the zero-air (8.5) toggle shut-off valve (D), pressurize the system to about 350 kPa above atmospheric pressure (50 psig), and close the valve. Read the pressure with the pressure gauge (7.3.19).

11.2.1.2 Recheck the pressure after approximately 3 h. If it has not dropped by more than 15 kPa (2 psig), the system is considered leak-tight.

11.2.1.3 If the system is leak-free, de-pressurize the system, close the zero air toggle shut-off (D), open the absolute pressure gauge toggle shut-off valve (C), and put the three-way valve in the sample position.

11.3 Sample Volume Determination:

11.3.1 Meter a precisely repeatable volume of sample air through the cryogenically cooled trap (7.3.3), using the vacuum reservoir (7.3.10) and absolute pressure gauge (7.3.9), as follows:

11.3.1.1 Close the sample toggle shut-off valve (A), open the vacuum toggle shut-off valve (B), and evacuate the vacuum reservoir (7.3.10) with the vacuum pump (7.3.14) to a predetermined initial vacuum (for example, 15 kPa (100 mm Hg)).

11.3.1.2 Then close the vacuum toggle shut-off valve (B) and open the sample toggle shut-off valve (A) to allow sample air to be drawn through the cryogenic trap (7.3.3) and into the evacuated vacuum reservoir (7.3.10) until a predetermined pressure is reached (for example, 40 kPa, (300 mm Hg)).

11.3.1.3 Determine the (fixed) volume of air thus sampled by the pressure rise in the vacuum reservoir (difference between the predetermined pressures) as measured by the absolute pressure gauge (7.3.9).

11.3.1.4 Allow the vacuum reservoir to come to thermal equilibrium before recording the pressure.

11.3.2 Determine the approximate sample volume as follows:

$$V_s = \frac{\Delta P V_r T_s}{P_s T_a} \quad (3)$$

where:

V_s = volume of air sampled, mL at standard conditions of 25° and 101.3 kPa,

ΔP = pressure difference measured by gauge, kPa (mm Hg),

V_r = volume of vacuum reservoir, (typically 1000 mL),

P_s = standard pressure, 101.3 kPa (760 mm Hg),

T_a = ambient temperature, K, and

T_s = standard temperature, 273 K.

11.3.2.1 For example, with a vacuum reservoir of 1000 mL, an ambient temperature of 20°C and a pressure change of 25 kPa, the volume sampled is approximately 251 mL.

NOTE 6—Typical sample volumes using this procedure are between 200 and 300 mL.

11.3.3 The sample volume determination need only be performed once during the system qualification/check-out and should be described in the laboratory's SOP for this method (see 12.1).

11.4 Analytical System Dynamic Calibration:

11.4.1 Perform a complete dynamic calibration of the analytical system before sample analysis, at five or more concentrations to define the calibration curve. Thereafter, periodically perform this procedure at least once during every series of analyses.

11.4.1.1 Include this in the laboratory's SOP (see 12.1).

11.4.1.2 Verify the calibration with two or three-point calibration checks (including zero) each day the analytical system is used to analyze samples.

11.4.2 Use concentration standards of either propane (8.4), benzene, or other suitable calibrant to calibrate the analytical system.

11.4.2.1 Sample the calibration standards directly from a vented manifold or tee.

NOTE 7—Remember that carbon concentration in propane in ppm C is three times the volumetric concentration in ppm (v).

11.4.3 Select one or more combinations of the following parameters to provide the desired range or ranges:

- (a) attenuator setting,
- (b) output voltage setting,
- (c) data reduction device resolution (if applicable), and
- (d) sample volume.

11.4.3.1 Calibrate each individual range separately and prepare a separate calibration curve for each range.

NOTE 8—Modern GC integrators and computer software will provide automatic ranging such that several decades of concentration may be programmed through a single range. Include applicable variations to the specific system design in the laboratory's SOP (see 12.1).

11.4.4 Analyze each calibration standard three times in accordance with the procedure in 11.3. Ensure that flow rates, pressure gauge start and stop readings, the initial cryogen level in the Dewar flask, timing, heating, data reduction device settings, and other variables are the same as those that will be used during analysis of ambient samples. Typical flow rates for the gases are:

- 11.4.4.1 *Hydrogen* (8.2), 30 mL/min,
- 11.4.4.2 *Helium Carrier* (8.2), 30 mL/min, and
- 11.4.4.3 *Combustion Air* (8.3), 400 mL/min.

11.4.5 Average the three analyses for each concentration standard and plot the calibration curves as the average integrated peak area reading versus concentration in ppm C. The relative standard deviation for the three analyses should be less than 3 % (except for zero concentration).

11.4.5.1 If the curve is not linear, repeat points that appear to deviate abnormally. FID response has been shown to be linear over a wide range (0 to 10 000 ppb C) (2). If nonlinearity is still observed, attempt to identify and correct the problem.

11.4.5.2 If the problem cannot be resolved, determine additional points in the nonlinear region to define the calibration curve adequately.

11.5 *Analysis Procedure:*

11.5.1 Ensure that the analytical system has been assembled properly, leak checked, and properly calibrated through a dynamic standard calibration.

11.5.1.1 Activate the FID (7.3.1) and allow it to stabilize.

11.5.2 Check and adjust the helium (8.2) carrier pressure to provide the correct carrier flow rate for the system. Helium is used to purge residual air and methane from the trap (7.3.3) at the end of the sampling phase and to carry the re-volatilized NMOC from the trap into the FID (7.3.1). A flow or pressure regulator (7.3.6) between the cylinder and the FID is recommended to regulate the helium pressure or flow better than the multistage cylinder regulator. When an auxiliary pressure regulator is used, the secondary stage of the two-stage regulator (7.3.5) must be set at a pressure higher than the pressure setting of the single-stage regulator (7.3.6). Also check the FID hydrogen (8.2) and combustion air (8.3) flow rates (see 11.4.4).

11.5.3 Close the sample toggle shut-off valve (A), and open the vacuum toggle shut-off valve (B) to evacuate the vacuum reservoir (7.3.10) to a specific predetermined value, for example, 15 kPa (100 mm Hg).

11.5.4 With the trap (7.3.3) at room temperature, place the six-port valve (7.3.4) in the inject position.

11.5.5 Open the sample toggle shut-off valve (a) and adjust the sample flow rate fine needle valve (7.3.7) for an appropriate trap flow of 50 to 100 mL/min.

NOTE 9—The flow will be lower when the trap is cold.

11.5.6 Check the sample canister pressure before attaching it to the analytical system and record it on the Sampling Data Sheet (see Fig. 5).

11.5.6.1 Connect the sample canister to the six-port valve (7.3.4), as shown in Fig. 3. Either the canister valve or the fine needle valve (7.3.7) installed between the canister and the vent (7.3.15) is used to adjust the canister flow rate to a value slightly higher than the trap flow rate set by the sample flow rate needle valve (7.3.7). The excess flow exhausts through the vent (7.3.15), which ensures that the sample air that flows through the trap (7.3.3) is at atmospheric pressure. Connect the vent to a flow indicator such as a rotameter (7.3.16) as an indication of vent flow to assist in adjusting the flow control fine needle valve (7.3.7).

11.5.6.2 Open the canister valve and adjust the canister or the sample flow fine needle valve (7.3.7) to obtain a moderate vent flow as indicated by the rotameter.

11.5.7 Close the sample toggle shut-off valve (a) and open the vacuum toggle shut-off valve (b) (if not already open) to evacuate the vacuum reservoir (7.3.10).

11.5.7.1 With the six-port valve (7.3.4) in the inject position and the vacuum toggle shut-off valve (B) open, open the sample toggle shut-off valve (A) for 2 to 3 minutes to flush and condition the inlet lines.

11.5.8 Close the sample toggle shut-off valve (A) and evacuate the vacuum reservoir (7.3.10) to the predetermined sample starting pressure (typically 15 kPa (100 mm Hg)) as indicated by the absolute pressure gauge (7.3.9).

11.5.9 Switch the six-port valve (7.3.4) to the trapping position.

11.5.10 Submerge the trap (7.3.3) in the cryogen (8.6). Allow a few minutes for the trap to cool (indicated when the cryogen stops boiling).

11.5.10.1 Add cryogen, as necessary, to maintain the initial level used during system dynamic calibration. Maintain the liquid level of the cryogen (8.6) constant with respect to the trap. Ensure that the glass-beaded portion of the trap is immersed in the cryogen (8.6), but not the fitting that connects the trap to the valve.

11.5.11 Open the sample toggle shut-off valve (A) and observe the increasing pressure on the absolute pressure gauge (7.3.9). When it reaches the specific predetermined pressure (typically 40 kPa (300 mm Hg)) representative of the desired sample volume (11.3, Eq 3), close the sample toggle shut-off valve (A).

11.5.12 Add a little cryogen (8.6) or elevate the Dewar flask to raise the liquid level to a point 3 to 15 mm higher than the initial level at the beginning of the trapping.

NOTE 10—This ensures that organic compounds do not bleed from the trap and are counted as part of the NMOC peaks.

11.5.13 Switch the six-port valve (7.3.4) to the inject position, keeping the Dewar flask (7.3.8) on the cryogenic trap (7.3.3) until the methane and upset peaks have diminished (10 to 20 s).

11.5.13.1 Now close the canister valve to conserve the remaining sample in the canister.

11.5.14 Energize the data reduction device (7.3.2) and remove the Dewar flask (7.3.8) from the trap (7.3.3).

11.5.15 Close the GC oven door (7.3.12) and allow the GC oven (or alternate trap heating system) to heat the trap (7.3.3) at a predetermined rate (typically, 30°C/min) to 90°C. Rapidly heating the trap volatilizes the concentrated NMOC as a uniform plug that enters the FID. A uniform trap temperature rise rate helps to reduce variability and facilitates more accurate correction for the moisture-shifted baseline. With a chromatograph oven to heat the trap, the following parameters have been found to be acceptable:

11.5.15.1 *Initial Temperature*, 30°C,

11.5.15.2 *Initial Start Time*, 0.20 min (following the start of the data reduction device),

11.5.15.3 *Temperature Rise Rate*, 30°/min, and

11.5.15.4 *Final Temperature*, 90°C.

11.5.16 Use the same heating process and temperatures for both calibration and sample analysis. Heating the trap (7.3.3) too quickly may cause an initial negative response that could hamper accurate integration. Some initial experimentation may be necessary to determine the optimal heating procedure for each system.

11.5.16.1 Once established, include the procedure established for each analysis in the laboratory's SOP (see 12.1).

11.5.17 Continue the integration (generally, in the range of 1 to 2 min is adequate) only long enough to include all of the organic compound peaks and to establish the end point FID baseline, as illustrated in Fig. 6. The data reduction device should be capable of marking the beginning and ending of peaks, constructing the appropriate operational baseline between the start and end of the integration period, and calculating the resulting corrected peak area. This ability is necessary because the moisture in the sample, which is also concentrated in the trap, will cause a slight positive baseline shift. This

baseline shift starts as the trap warms and continues until all of the moisture is swept from the trap, at which time the baseline returns to its normal level. The shift always continues longer than the ambient organic peak(s).

11.5.17.1 Program the data reduction device to correct for this shifted baseline by ending the integration at a point after the last NMOC peak and prior to the return of the shifted baseline to normal (see Fig. 6), so that the calculated operational baseline effectively compensates for the water-shifted baseline. Electronic data reduction devices either do this automatically or can be programmed to make this correction.

11.5.17.2 Alternatively, perform analyses of humidified zero-air (8.5) prior to sample analyses to determine the water envelope and the proper blank value for correcting the ambient air concentration measurements.

11.5.17.3 Continue heating and flushing the trap after the integration period has ended to ensure that all the water has been removed to prevent buildup of water in the trap. Be sure that the six-port valve (7.3.4) remains in the inject position until all moisture has purged from the trap (3 min or longer).

11.5.18 Use the dynamic calibration curve (see 11.4) to convert the integrated peak area reading into concentration units (ppm C).

11.5.19 Analyze each canister sample at least twice and report the average NMOC concentration. The NMOC peak shape may not be precisely reproducible due to variations in the heating of the trap, but the total NMOC peak area should be reproducible. Problems during an analysis occasionally will cause erratic or inconsistent results.

11.5.19.1 If the first two analyses do not agree within ±10 %, perform additional analyses to identify the source of the problem and produce a more precise measurement (see also 11.3).

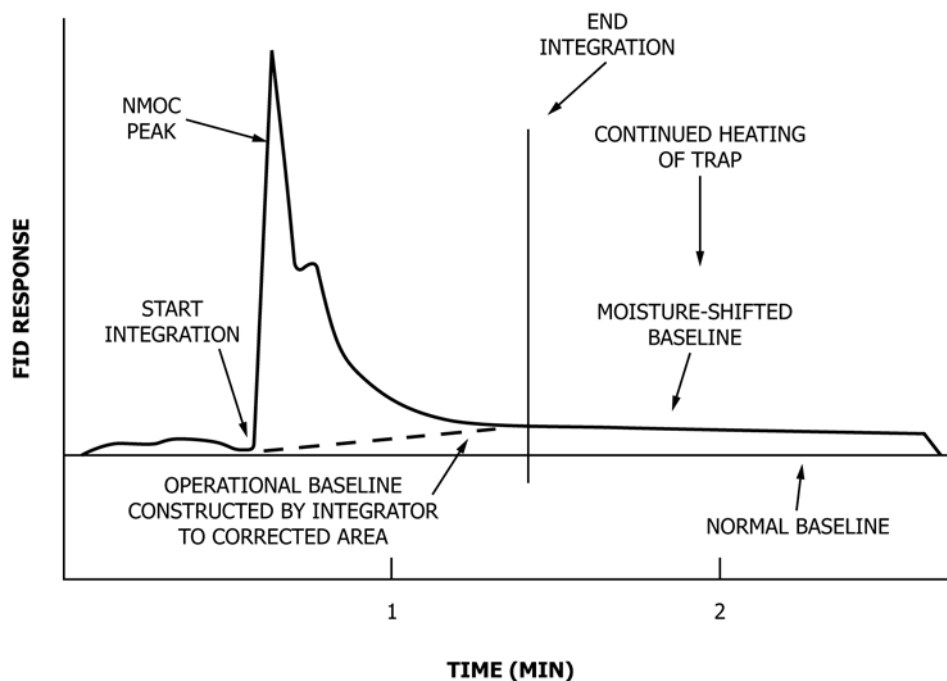

FIG. 6 Construction of Operational Baseline and Corresponding Correction of Peak Area

12. Performance Criteria and Quality Assurance

12.1 This section summarizes required quality assurance measures and provides guidance concerning performance criteria that should be achieved within each laboratory.

12.2 *Standard Operating Procedures:*

12.2.1 Describe and document in SOPs the following activities: (1) assembly, calibration, leak check, and operation of the specific sampling system and equipment used; (2) preparation, storage, shipment, and handling of samples; (3) assembly, leak-check, calibration, and operation of the analytical system, addressing the specific equipment used; (4) canister storage and cleaning; and (5) all aspects of data recording and processing, including lists of computer hardware and software used.

12.2.2 Include specific stepwise instructions in the SOPs. Verify by audits that they are readily available to, and understood by, the laboratory personnel conducting the work.

12.3 *Test Method Sensitivity, Accuracy and Precision:*

12.3.1 The sensitivity and precision of the test method is proportional to the sample volume. However, ice formation in the trap may reduce or stop the sample flow during trapping if the sample volume exceeds 500 mL. Sample volumes below about 100 to 150 mL may cause increased measurement variability due to dead volume in lines and valves. For most typical ambient NMOC concentrations, sample volumes in the range of 200 to 300 mL appear to be appropriate. If a response peak obtained with a 300 mL sample is off scale or exceeds the calibration range, perform a second analysis with a smaller volume. The actual sample volume analyzed need not be accurately known if exactly the same volume is used for both the calibration and sample analysis. Similarly, the actual volume of the vacuum reservoir need not be accurately known. Match the reservoir volume to the pressure range and resolution of an absolute gauge so that the measurement of pressure change, and hence the sample volume, is repeatable within 1 %. A 1000 mL vacuum reservoir and a pressure change of 30 kPa (200 mm Hg), measured with the specified pressure gauge, have provided a sampling precision of ± 1.31 mL. Use a smaller volume vacuum reservoir with a greater pressure change to accommodate absolute pressure gauges with lower resolution, and vice versa.

12.3.2 Some FID systems associated with laboratory chromatographs may have autoranging capabilities. Others may provide attenuator control and internal full-scale output voltage selectors. Choose an appropriate combination so that an adequate output level for accurate integration is obtained down to the detection limit; however, the data reduction device must not be driven into saturation at the upper end of the calibration. Saturation of the electrometer may be indicated by flattening of the calibration curve at high concentrations. Additional adjustments of range and sensitivity can be provided by adjusting the sample volume used, as discussed in 12.2.1.

12.3.3 Some organic compounds contained in ambient air may be difficult to recover because of retention in the canister or trap, and may require repeated analyses before they fully appear in the FID output. Also, some adjustment may be required in the data reduction device off time setting to

accommodate compounds that reach the FID late in the analysis cycle. Similarly, such compounds from ambient samples or from contaminated propane standards may temporarily contaminate the analytical system and can affect subsequent analyses. Such temporary contamination can usually be removed by repeated analyses of humidified zero-air (8.5).

12.3.4 Simultaneous collection of duplicate samples decreases the possibility of lost measurement data from samples lost due to leakage or contamination in any of the canisters. Two (or more) canisters can be filled simultaneously by connecting them in parallel (see Fig. 1) and selecting an appropriate flow rate to accommodate the number of canisters (see Eq 1). Duplicate (or replicate) samples also allow assessment of measurement precision based on the differences between the measured concentrations of duplicate samples (or the standard deviations among replicate samples). The target criteria should be at least that of precision given in Section 14.

13. Test Method Modification

13.1 *Sample Metering System:*

13.1.1 Although the vacuum reservoir and absolute pressure gauge technique for metering the sample volume during analysis is efficient and convenient, other techniques may prove effective.

13.1.2 A constant sample flow can be established with a mass flow meter, or a vacuum pump and a critical orifice, with the six-port valve being switched to the sample position for a measured time period. A gas volume meter, such as a wet test meter, can also be used to measure the total volume of sample air drawn through the trap. Test and evaluate these alternative techniques as part of the laboratory's SOP (see 12.1).

13.2 *Canister Cleaning:*

13.2.1 The canisters may be cleaned without heating to 100°C if the evacuation/pressurization cycles are repeated a minimum of four times and the blank test yields results below the detection limit for NMOCs.

13.3 *FID System:*

13.3.1 A variety of FID systems are adaptable to this method.

13.3.2 Evaluate the specific flow rates and necessary modifications for the helium carrier for any alternative FID instrument prior to use as part of the laboratory's SOP.

13.4 *Range:*

13.4.1 It may be possible to improve the sensitivity of the method by increasing the sample volume. However, limitations may arise such as the plugging of the trap by ice.

13.4.2 Evaluate attempts to increase sensitivity as part of the laboratory's SOP.

13.5 *Alternate Cryogenic Trapping and Heating System:*

13.5.1 Other automatic cryogenic trapping systems that are coupled with alternate heating sources may be used in place of the immersion trap, Dewar flask, and oven.

NOTE 11—Trapping, heating, and water management are critical to accurate NMOC determination. Retaining C2 components is an important indicator of acceptable water management without component losses. The user is reminded that many applications will require documentation showing that all the related performance specifications are satisfied when an alternative cryogenic trapping and heating system is employed.

13.6 Sub-Atmospheric Pressure Canister Sampling:

13.6.1 Collection and analysis of canister air samples collected at subatmospheric pressure is also possible with minor modifications to the sampling and analytical procedures. Test Method **D5466** and Refs **(9-13)** describe sub-atmospheric pressure canister sampling. Document any procedure developed in the laboratory's SOP (see **12.1**).

13.7 Alternate Sampling System:

13.7.1 Other canisters with inert interiors may be possible to be used. Their characteristics should be evaluated prior to use.

14. Precision and Bias

14.1 Precision (1):

14.1.1 Precision for this test method was established by acquiring duplicate samples and analyzing each sample twice. A total of 37 duplicate samples were taken for U.S. EPA's NMOC Program in 1990. The values ranged from 0.16 to 2.41 ppm C. The samples came from sites nationwide.

14.1.2 The average precision measured was 0.70 ppm C with an average absolute relative percent difference of 12.7.

14.2 Bias (1):

14.2.1 Bias for this test method was established by analyzing four audit cylinders acquired from the USEPA Quality Assurance Branch. The cylinders were prepared by diluting a reference cylinder of propane, which was traceable to the National Institute of Standards and Technology (NIST). Each audit cylinder was sampled and analyzed four times.

14.2.2 The average bias determined was 0.04 ppm C, with an average absolute percent bias of 3.74.

15. Keywords

15.1 ambient atmospheres; analysis; atmospheres; canister sampling; cryogenic pre-concentration; flame ionization detection; indoor atmospheres; non-methane organic compounds; sampling; workplace atmospheres

REFERENCES

- (1) McAllister, R. A., O'Hara, P. L., Dayton, D-P., Robbins, J. E., Jongleux, R. F., Merrill, R. G., Rice, J., and Bowes, E. G., "1990 Nonmethane Organic Compound and Three-Hour Air Toxics Monitoring Program," Final Report to EPA Contract 68080014, Radian Corp., Research Triangle Park, NC, January, 1991.
- (2) Jayanty, R. K. M., Blanchard, A., McElroy, F. F., and McClenny, W. A., "Laboratory Evaluation-Nonmethane Organic Carbon Determination in Ambient Air by Cryogenic Preconcentration and Flame Ionization Detection," EPA-600/54-82-019, U.S. Environmental Protection Agency, Research Triangle Park, NC, July 1982.
- (3) "Technical Assistance Document for Sampling and Analysis of Toxic Organic Compounds in Ambient Air," EPA-600/483-80/008, U.S. Environmental, Research Triangle Park, NC, June 1980.
- (4) Cox, R. D., McDevitt, M. A., Lee, K. W., and Tannahill, G. K., "Determination of Low Levels of Total Non-Methane Hydrocarbon Content in Ambient Air," *Environmental Science and Technology*, Vol 16, No. 1, 1982, p. 57.
- (5) McElroy, F. F., Thompson, V. L., Holland, D. M., Lonneman, W. A., and Seila, R. L., "Cryogenic Preconcentration—Direct FID Method for Measurement of Ambient NMOC: Refinement and Comparison with GC Speciation," *Journal of the Air Pollution Control Association*, Vol 36, No. 6, 1986, pp. 710–714.
- (6) Sexton, F. W., McElroy, F. F., Michie, Jr., R. M., and Thompson, V. L., "A Comparative Evaluation of Seven Automated Ambient Non-Methane Organic Compound Analyzers," EPA-600/5482-046, U.S. Environmental Protection Agency, Research Triangle Park, NC, August 1982.
- (7) Richter, H. G., "Analysis of Organic Compound Data Gathered During 1980 in Northeast Corridor Cities," EPA-450/4-83-017, U.S. Environmental Protection Agency, Research Triangle Park, NC, April 1983.
- (8) "Uses, Limitations, and Technical Basis of Procedures for Quantifying Relationships Between Photochemical Oxidants and Precursors," EPA-450/2-77-a, U.S. Environmental Protection Agency, Research Triangle Park, NC, November 1977.
- (9) Rasmussen, R. A., and Khalil, M. A. K., "Atmospheric Halocarbons: Measurements and Analyses of Selected Trace Gases," Proceedings NATO ASI on Atmospheric Ozone, 1980, pp. 209–231.
- (10) Oliver, K. D., Pleil, J. D., and McClenny, W. A., "Sample Integrity of Trace Level Volatile Organic Compounds in Ambient Air Stored in 'Summa' Polished Canisters," *Atmospheric Environment*, Vol 20, No. 7, 1986, pp. 1403–1411.
- (11) McClenny, W. A., Pleil, J. D., Holden, J. W., and Smith, R. N., "Automated Cryogenic Preconcentration and Gas Chromatographic Determination of Volatile Organic Compounds," *Analytical Chemistry*, Vol 56, 1984, p. 2947.
- (12) Pleil, J. D., Oliver, K. D., and McClenny, W. A., "Enhanced Performance of Nafion Dryers in Removing Water from Air Samples Prior to Gas Chromatographic Analysis," *Journal of the Air Pollution Control Association*, Vol 37, No. 3, 1987, pp. 244–248.
- (13) Oliver, K. D., Pleil, J. D., "Automated Cryogenic Sampling and Gas Chromatographic Analysis of Ambient Vapor-Phase Organic Compounds: Procedures and Comparison Tests," EPA Contract No. 68-02-4035, Research Triangle Park, NC, Northrop Services, Inc., Environmental Sciences, 1985.
- (14) McClenny, W. A., Pleil, J. D., Oliver, K. D., Oliver, M. W., and Winberry, "Canister-Based Method for Monitoring Toxic VOCs in Ambient Air," *Journal of the Air and Waste Management Association*, Vol 41, 1991, pp. 1308–1318.

ASTM International takes no position respecting the validity of any patent rights asserted in connection with any item mentioned in this standard. Users of this standard are expressly advised that determination of the validity of any such patent rights, and the risk of infringement of such rights, are entirely their own responsibility.

This standard is subject to revision at any time by the responsible technical committee and must be reviewed every five years and if not revised, either reapproved or withdrawn. Your comments are invited either for revision of this standard or for additional standards and should be addressed to ASTM International Headquarters. Your comments will receive careful consideration at a meeting of the responsible technical committee, which you may attend. If you feel that your comments have not received a fair hearing you should make your views known to the ASTM Committee on Standards, at the address shown below.

This standard is copyrighted by ASTM International, 100 Barr Harbor Drive, PO Box C700, West Conshohocken, PA 19428-2959, United States. Individual reprints (single or multiple copies) of this standard may be obtained by contacting ASTM at the above address or at 610-832-9585 (phone), 610-832-9555 (fax), or service@astm.org (e-mail); or through the ASTM website (www.astm.org). Permission rights to photocopy the standard may also be secured from the Copyright Clearance Center, 222 Rosewood Drive, Danvers, MA 01923, Tel: (978) 646-2600; <http://www.copyright.com/>