



# Standard Guide for Storage and Handling of Geosynthetic Clay Liners<sup>1</sup>

This standard is issued under the fixed designation D5888; the number immediately following the designation indicates the year of original adoption or, in the case of revision, the year of last revision. A number in parentheses indicates the year of last reapproval. A superscript epsilon ( $\epsilon$ ) indicates an editorial change since the last revision or reapproval.

## 1. Scope

1.1 This guide covers guidelines for the proper storage and handling of geosynthetic clay liners received at the job site by the end user.

1.2 This guide contains general guidelines and is not intended to replace project-specific requirements as found in the contract drawings or specifications. In the event of a conflict, the requirements of the project specifications will supersede the requirements of this practice.

1.3 The values given in SI units are to be regarded as the standard. The inch-pound units given in parentheses are for information only.

1.4 *This guide offers an organized collection of information or a series of options and does not recommend a specific course of action. This document cannot replace education or experience and should be used in conjunction with professional judgement. Not all aspects of this guide may be applicable in all circumstances. This ASTM standard is not intended to represent or replace the standard of care by which the adequacy of a given professional service must be judged, nor should this document be applied without consideration of a project's many unique aspects. The word "Standard" in the title of this document means only that the document has been approved through the ASTM consensus process.*

1.5 *This standard does not purport to address all of the safety concerns, if any, associated with its use. It is the responsibility of the user of this standard to establish appropriate safety and health practices and determine the applicability of regulatory limitations prior to use.*

## 2. Referenced Documents

2.1 *ASTM Standards:*<sup>2</sup>

[D4439 Terminology for Geosynthetics](#)

<sup>1</sup> This guide is under the jurisdiction of ASTM Committee D35 on Geosynthetics and is the direct responsibility of Subcommittee D35.04 on Geosynthetic Clay Liners.

Current edition approved June 1, 2016. Published June 2016. Originally approved in 1995. Last previous edition approved in 2011 as D5888 – 06(2011). DOI: 10.1520/D5888-06R16.

<sup>2</sup> For referenced ASTM standards, visit the ASTM website, [www.astm.org](http://www.astm.org), or contact ASTM Customer Service at [service@astm.org](mailto:service@astm.org). For *Annual Book of ASTM Standards* volume information, refer to the standard's Document Summary page on the ASTM website.

## 3. Terminology

3.1 *Definitions:*

3.1.1 *core pipe, n*—a rigid pipe or rod inserted through the core of a GCL roll. Each end of the pipe is connected to a chain or lifting strap which attaches to equipment for GCL unloading, on-site handling, and installation.

3.1.2 *geosynthetic clay liner (GCL), n*—a manufactured hydraulic barrier consisting of clay bonded to a layer or layers of geosynthetics.

3.1.3 *spreader bar, n*—a steel beam used in conjunction with the core pipe that prevents the lifting chains or straps from chafing against the ends of the GCL roll.

3.1.4 *stinger, n*—a rigid pipe or rod with one end directly connected to a forklift or other equipment. The opposite end of the stinger can then be inserted through the GCL roll core such that the equipment is able to unload, handle, or install the GCL.

3.1.5 For definitions of other geosynthetic terms used in this practice, refer to Terminology [D4439](#).

## 4. Significance and Use

4.1 For optimum performance, GCLs must be stored and handled prior to their installation in a manner that does not impact their physical properties. Adherence to these storage and handling guidelines will help to ensure that acceptable GCL performance will be achieved.

## 5. Procedure

5.1 *Receiving and Handling GCL at the Job Site:*

5.1.1 The GCLs are packaged in individual rolls and are typically delivered to the job site in trucks. Each roll is individually wrapped and labeled by the GCL manufacturer. Prior to unloading the rolls, make a visual examination of the shipment in order to identify any damage that may have occurred in transit to the site. Record and report any immediately visible or suspected damage to the GCL rolls immediately to the GCL carrier and to the supplier. Tag, mark, and segregate damaged rolls.

5.1.2 Unloading the rolls from the delivery vehicle must be done in manner that prevents damage to the GCL and its packaging.

NOTE 1—A pipe or solid bar of sufficient strength to support the full weight of the GCL roll without significant bending should be used for all

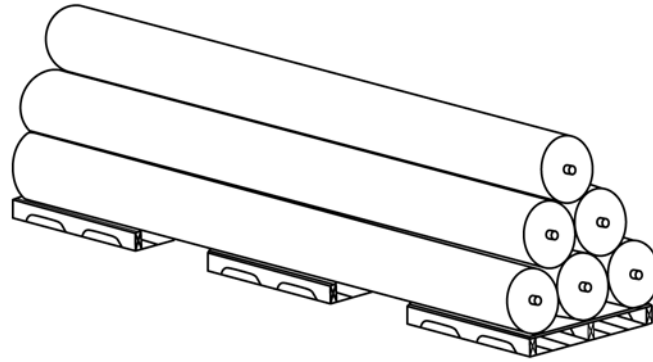

**FIG. 1 GCLs Stored Off the Ground and Evenly Supported On Pallets**

unloading and handling activities. The diameter of the pipe should be small enough to be easily inserted through the core of the GCL. High-strength straps or chains should link the ends of the core pipe to the ends of the spreader bar facilitate lifting the roll with a backhoe or other equipment. Care must be taken to ensure that the lifting straps/chains do not rub against the GCL.

5.1.2.1 Alternately, the GCL may be unloaded and handled using a “stinger” bar protruding from the front end of a forklift or other equipment. The stinger should be at least three fourths the length of the core and also must be capable of supporting the full weight of the GCL without significant bending.

5.1.2.2 If recommended by the manufacturer, a sling handling method utilizing appropriate loading straps can be used.

5.1.3 Under no circumstances should the GCL rolls be dragged, lifted by one end, pushed to the ground from the delivery vehicle, or otherwise unloaded in a fashion that could damage the GCL.

5.1.4 Immediately repair any tears in the packaging discovered during unloading activities using tape and plastic sheeting as necessary to restore a waterproof protective barrier around the GCL. Examine the GCL itself for damage wherever torn packaging is observed.

## 5.2 Storing the GCL at the Job Site:

5.2.1 Store GCL rolls in their original, unopened packaging in a location away from construction traffic but sufficiently close to the active work area to minimize handling. The designated storage area should be level, dry, well-drained, stable, and should protect the GCL from:

- 5.2.1.1 Precipitation,
- 5.2.1.2 Standing water,
- 5.2.1.3 Ultraviolet radiation,

5.2.1.4 Chemicals,

5.2.1.5 Open flames and welding sparks,

5.2.1.6 Temperatures in excess of 71°C (160°F),

5.2.1.7 Vandalism, animals, and

5.2.1.8 Any other environmental condition that could impact the physical properties of the GCL.

5.2.2 To facilitate the installation process, store the GCL such that it is protected from freezing.

5.2.3 Always store GCL rolls lying flat, sufficiently supported as to not cause localized contact points. Rolls may be placed on the ground if ponding of water in the storage area is prevented. It is recommended that the rolls be placed on blocks or pallets of sufficient quantity so as to have at least 50% of the rolls evenly supported (see Fig. 1). The rolls may be stacked upon one another, provided they are placed in a manner that prevents them from sliding or rolling from the stack. The recommended stack height is three rolls. The height of the stack should be limited to that at which safe access is provided to equipment and laborers, and at which roll cores at the bottom of the stack are not distorted or crushed.

5.2.4 If the integrity of the GCL packaging has not been affected during the shipping and unloading processes, and if the storage requirements listed herein are achieved, then the rolls may be stored on site with a waterproof tarpaulin or plastic sheet placed over the GCL stockpile. Enclosed indoor storage is preferred if the GCL rolls are to be stored for the long term.

## 6. Keywords

6.1 GCL; geosynthetic clay liner; handling; storage

*ASTM International takes no position respecting the validity of any patent rights asserted in connection with any item mentioned in this standard. Users of this standard are expressly advised that determination of the validity of any such patent rights, and the risk of infringement of such rights, are entirely their own responsibility.*

*This standard is subject to revision at any time by the responsible technical committee and must be reviewed every five years and if not revised, either reapproved or withdrawn. Your comments are invited either for revision of this standard or for additional standards and should be addressed to ASTM International Headquarters. Your comments will receive careful consideration at a meeting of the responsible technical committee, which you may attend. If you feel that your comments have not received a fair hearing you should make your views known to the ASTM Committee on Standards, at the address shown below.*

*This standard is copyrighted by ASTM International, 100 Barr Harbor Drive, PO Box C700, West Conshohocken, PA 19428-2959, United States. Individual reprints (single or multiple copies) of this standard may be obtained by contacting ASTM at the above address or at 610-832-9585 (phone), 610-832-9555 (fax), or service@astm.org (e-mail); or through the ASTM website (www.astm.org). Permission rights to photocopy the standard may also be secured from the Copyright Clearance Center, 222 Rosewood Drive, Danvers, MA 01923, Tel: (978) 646-2600; http://www.copyright.com/*