



# Standard Specification for Adhesives Used for Laminate Joints in Nonstructural Lumber Products<sup>1</sup>

This standard is issued under the fixed designation D5751; the number immediately following the designation indicates the year of original adoption or, in the case of revision, the year of last revision. A number in parentheses indicates the year of last reapproval. A superscript epsilon ( $\epsilon$ ) indicates an editorial change since the last revision or reapproval.

## 1. Scope

1.1 This specification covers performance levels for adhesives to be used in laminate joints in nonstructural lumber products. Such products include, but are not limited to, interior and exterior mouldings, window and door components or parts, and bonded lumber panels. This specification is to be used to evaluate adhesives as well as the adhesive bonds in nonstructural-glued-lumber products.

NOTE 1—This specification supersedes the laminate-joint portion of Specification D3110.

NOTE 2—See 3.2.1 and 3.2.2 for descriptions of a dry-use-nonstructural adhesive and a wet-use-nonstructural adhesive.

1.2 This specification applies to laminate-joint specimens made under both laboratory and field conditions. See Section 4 for limitations in using this specification to evaluate industrially manufactured laminate joint products.

1.3 The following safety caveat applies only to the apparatus and test methods portions, Sections 6, 7, 8, and 9 of this specification: *This standard does not purport to address all of the safety concerns, if any, associated with its use. It is the responsibility of the user of this standard to establish appropriate safety and health practices and determine the applicability of regulatory limitations prior to use.*

1.4 The values stated in inch-pound units are to be regarded as standard.

1.5 In this specification, *laminate joint* refers to both face and edge joints.

1.6 The following index is provided as a guide to the test methods in this specification:

	Section
Apparatus	6
Conditioning	7
Material and Preparation of Assemblies and Specimens	8
Exposure Conditions and Treatments	9
Testing, Calculation, and Reporting	10

<sup>1</sup> This specification is under the jurisdiction of ASTM Committee D14 on Adhesives and is the direct responsibility of Subcommittee D14.30 on Wood Adhesives.

Current edition approved Oct. 1, 2012. Published October 2012. Originally approved in 1995. Last previous edition approved in 2005 as D5751 – 99 (2005). DOI: 10.1520/D5751-99R12.

NOTE 3—The conditioning needed for various stages in the preparation of the specimens and for the exposure tests are given in Sections 7, 8, and 9.

## 2. Referenced Documents

2.1 *ASTM Standards*:<sup>2</sup>

D905 Test Method for Strength Properties of Adhesive Bonds in Shear by Compression Loading

D907 Terminology of Adhesives

D2016 Methods of Test for Moisture Content of Wood (Withdrawn 1987)<sup>3</sup>

D2555 Practice for Establishing Clear Wood Strength Values

D3110 Specification for Adhesives Used in Laminate Joints for Nonstructural Glued Lumber Products (Withdrawn 1996)<sup>3</sup>

D5266 Practice for Estimating the Percentage of Wood Failure in Adhesive Bonded Joints

E4 Practices for Force Verification of Testing Machines

E6 Terminology Relating to Methods of Mechanical Testing

E41 Terminology Relating To Conditioning

E177 Practice for Use of the Terms Precision and Bias in ASTM Test Methods

E691 Practice for Conducting an Interlaboratory Study to Determine the Precision of a Test Method

## 3. Terminology

3.1 *Definitions*: Many terms in this specification are defined in Terminologies D907, E6, and E41.

3.1.1 *bond, n*—the union of materials by adhesives.

3.1.2 *laminate joint, n—in wood bonding*, a joint made by bonding layers of adherends face-to-face or edge-to-edge to form thicker or wider stock.

3.1.3 *edge joint, n—in wood bonding*, a type of laminate joint made by bonding adherends edge-to-edge with grain directions parallel to form wider stock.

<sup>2</sup> For referenced ASTM standards, visit the ASTM website, www.astm.org, or contact ASTM Customer Service at service@astm.org. For *Annual Book of ASTM Standards* volume information, refer to the standard's Document Summary page on the ASTM website.

<sup>3</sup> The last approved version of this historical standard is referenced on www.astm.org.

3.1.4 *face joint, n—in wood bonding*, a type of laminate joint made by bonding adherends face-to-face with grain directions parallel to form thicker stock.

3.2 *Definitions of Terms Specific to This Standard:*

3.2.1 *dry-use nonstructural adhesive, n—* an adhesive capable of producing sufficient strength and durability to make the bonded lumber product serviceable in nonstructural use, under conditions in which the EMC of the wood does not exceed 16 %.

3.2.2 *wet-use nonstructural adhesive, n—* an adhesive capable of producing sufficient strength and durability to make the bonded lumber product serviceable in nonstructural use, under conditions in which the EMC of the wood may be 16 % or greater.

3.3 *Abbreviations:*

3.3.1 *EMC*—equilibrium moisture content.

3.3.2 *MC*—moisture content.

4. Significance and Use

4.1 Adhesives are classified as dry use or wet use. Each classification includes consideration of short-term in-transit exposure conditions at temperatures up to 220°F. These test methods are designed to determine the performance level of a nonstructural wood adhesive when used in a laminate joint. See Fig. 1 for a depiction of a laminate joint.

4.1.1 The dry test and exposure conditions and treatments are to evaluate adhesives and adhesive bonds of laminate joints in nonstructural bonded lumber products for typical service conditions.

4.1.2 The 220°F test, a more severe test, is designed to evaluate the product after exposure to short-term elevated

temperature. This test method is intended to simulate conditions that might be experienced in transit, further processing, or in service.

NOTE 4—These typical service conditions may include stress and time under stress, as well as elevated temperature.

4.2 This specification may be used to evaluate the adhesive bonds in a laminate joint that is the industrial-end product of a manufacturing process. The use of the specification for this purpose requires close evaluation of the configuration of the joint, the wood used, and the manufacturing process.

4.2.1 An industrially manufactured laminate joint should be evaluated using the requirements for compliance to the specification set forth in 5.1.1, 5.1.2, and 5.2.

4.2.2 To measure up to the criteria of the controlled conditions of a laboratory-made specimen, hand pick the lumber, prepare extra joints, and select those joints that most closely meet the requirements of 5.1 and 5.2.

4.3 Special circumstances may require modification of some of the details of these procedures. Record these variations in the report sections, as they may have an impact on the results obtained.

4.4 As the industrially manufactured laminate joint product is often handled, machined, and shipped within a few hours of manufacture, it may not have reached the maximum performance level before it is shipped or tested. To avoid potential product damage, the adhesive-performance level should be determined by the laminate-joint manufacturer prior to initial handling and early shipment. Before beginning the full testing process, the testing laboratory should ensure that the product

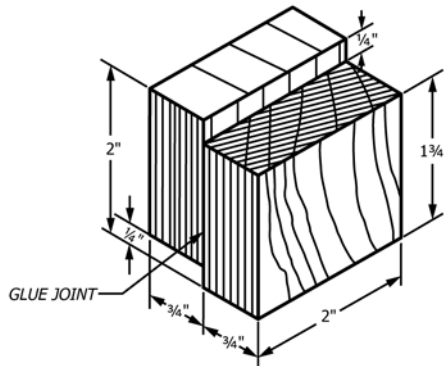

Dimension	Dimensions:	
	Face Joint (Example) <sup>A</sup>	
	Measurement, in. (mm)	Tolerance, in. (mm)
Specimen width	2 (50.8)	+ 0.32 (0.79)
Single lamina length	1.75 (44.4)	+ 0.32 (0.79)
Single lamina thickness (preferred)	0.75 (19)	+ 0.010 (0.25)
Single lamina thickness (alternative)	0.688 (17.5)	+ 0.010 (0.25)
Overall specimen thickness	1.5 (38.1)	+ 0.32 (0.79)
Overlap between adherends	1.5 (38.1)	+ 0.32 (0.79)

<sup>A</sup> The ratio of width to height should be maintained at 4/3.

FIG. 1 Block Shear Specimens

**TABLE 1 Minimum Test Requirements**

Performance Classification and Exposure Conditions <sup>A</sup>	Paragraph No. for Exposure Description	Laminate Joint in Shear <sup>B</sup>					
		Strength <sup>C</sup>		%Wood Failure <sup>D</sup>			
		Group Average, % <sup>E</sup>	Individual Minimum, % <sup>F, G</sup>	Group Average, % <sup>E, G</sup>		Individual Minimum, % <sup>F, G</sup>	
				Soft Wood	Hard Wood	Soft Wood	Hard Wood
Dry Use:							
Cured (Dry)	9.1.1	60	30	60	30	30	15
Three-Cycle Soak	9.1.2	30	15	30	15	15	H
Elevated Temperature (220°F)	9.1.3	40	20	40	20	20	H
Wet Use:							
Cured (Dry)	9.2.1	60	30	60	30	30	15
Boil	9.2.2	50	25	50	25	25	H
Elevated Temperature (220°F)	9.2.3	40	20	40	20	20	H
Vacuum Pressure	9.2.4	50	25	50	25	25	H

<sup>A</sup> Twenty specimens are required for each classification and exposure.

<sup>B</sup> Parallel to the grain.

<sup>C</sup> The shear strength of the test specimens expressed as a percentage of the average shear strength of the wood species at 12 % MC. (See Table 2.) Adjustments are required for lower MC values. (See Footnote A in Table 2 (a).)

<sup>D</sup> The wood failure values given are for softwoods and hardwoods. Groups 3 and 4 hardwoods (Table 3) are listed at 50 % of the softwood value, with no requirement if the wood failure value calculates to 15 % or less. (See 5.1.2.2 and Table 3.)

<sup>E</sup> For all specimens tested.

<sup>F</sup> For 90 % of the specimens tested, they shall meet or exceed the minimum wood failure values shown. If a zero value is obtained for any of the specimens, the test shall be ruled a failure.

<sup>G</sup> See recommended average specific gravity in Table 4.

<sup>H</sup> No requirement.

conforms with the performance level certified by the adhesive manufacturer and has not been damaged by early handling and shipping.

## 5. Test Requirements

### 5.1 Test Adhesive:

5.1.1 To comply with this specification, the test adhesive shall be tested for performance in accordance with Sections 7 through 10, and it shall meet the requirements in Table 1 for the selected performance classification as measured against the average shearing strength of lumber from common species of wood as shown on Table 2(a) and Table 2(b).

5.1.1.1 For certification, a test shall be conducted on a laminate joint using the test adhesive.

5.1.1.2 Lumber with various grain orientations (for example, flat sawn or quarter sawn) shall be allowed to be used interchangeably, provided they do not fall outside the requirements of 8.1.1.

5.1.2 Compliance with this specification shall warrant certification of the adhesive for use on a designated grouping of wood, either softwood or hardwood, when tested and found to be in accordance with any one of the species of that group. See Table 3 for the designated groupings of commonly used domestic and imported woods, as accepted in this specification.<sup>4</sup>

5.1.2.1 The wood failure requirements of Table 1 are given for softwoods, Groups 1 and 2, and for hardwoods, Groups 3 and 4.

5.1.2.2 In the event that the adhesive user or supplier, or both, cannot accept the designated groupings in Table 3, either party shall have the option of requesting a test on an individual species.

5.2 *Industrially Manufactured Laminate Joints*—An industrially manufactured laminate joint may be used to evaluate the adhesive used to produce it, provided its construction meets the requirements in Sections 7 and 8, and the joint is tested in accordance with the requirements in Table 1.

## 6. Apparatus

6.1 *Environmental Chambers*—For moist-heat aging, capable of conditioning specimens at 80 ± 5°F (27 ± 3°C) and 80 ± 5 % relative humidity, and with capacity for up to 20 specimens well-spaced and supported on racks to allow free air flow.

6.2 *Oven(s)*—Capable of meeting all the temperature requirements of 9.1.2, 105 ± 5°F (41 ± 3°C); 9.1.3, 220 and 230 ± 5°F (104 and 110 ± 3°C); 9.2.2 and 9.2.3, 145 ± 5°F (63 ± 3°C), with sufficient air circulation to remove moisture from the chamber. An oven capable of enclosing the testing machine is also recommended. (See 9.1.3.1.)

6.3 *Tank for Soaking*, meeting the requirements of 9.1.2, so that all of the specimens are completely covered with water for the duration of the soak cycles.

6.4 *Tank for Boiling*, meeting the requirements of 9.2.2, so that all of the specimens are completely covered with water for the duration of the boil cycles.

6.5 *Testing Machine*—Capacity of not less than 15 000 lb (6810 kg) in compression, fitted with a shearing tool containing

<sup>4</sup> For wood property information on imported woods, refer to U.S. Forest Service, Agricultural Handbook No. 72, *Wood Handbook*, 1987 ed., Table 4.4.

**TABLE 2 (a) Average Shear Strength of Common Woods at 12 % Moisture Content, psi<sup>A</sup>**

Species <sup>B</sup>	Green Value	Dry to Green Ratio <sup>C</sup>	100 % Value	60 % Value	50 % Value	40 % Value	25 % Value	20 % Value	15 % Value
Cedar, Incense Incense	834	1.05	878	527	439	351	220	176	132
Douglas-Fir, Coast-Type	904	1.25	1130	678	565	452	282	226	170
Fir, White	756	1.46	1104	662	552	442	276	221	166
Hemlock, Western	864	1.49	1287	772	644	515	322	257	193
Pine, Ponderosa	704	1.61	1133	680	567	453	283	227	170
Pine, Sugar	718	1.58	1134	680	567	454	284	227	170
Redwood <sup>D</sup>	894	1.25	1118	671	559	447	280	224	168

<sup>A</sup> For tests conducted in which the wood moisture content is less than or greater than 12 %, the measured strength should be adjusted upward 3 % for each 1 % decrease in moisture content, or downward 3 % for each 1 % increase in moisture content.

<sup>B</sup> For these or other species, values are those for shear parallel to the grain in Test Methods D2555, adjusting to 12 % moisture content using the ratios of dry to green clear wood properties of Test Methods D2555.

<sup>C</sup> Ratio of dry to green strength in Test Methods D2555.

<sup>D</sup> Second growth.

**TABLE (b) Average Shear Strength of Common Woods at 12 % Moisture Content, MPa<sup>A</sup>**

Species <sup>B</sup>	Green Value	Dry to Green Ratio <sup>C</sup>	100 % Value	60 % Value	50 % Value	40 % Value	25 % Value	20 % Value	15 % Value
Cedar, Incense Incense	5.75	1.05	6.05	3.63	3.03	2.42	1.52	1.21	0.91
Douglas-Fir, Coast-Type	6.23	1.25	7.79	4.67	3.90	3.12	1.94	1.56	1.17
Fir, White	5.21	1.46	7.61	4.56	3.80	3.05	1.90	1.52	1.14
Hemlock, Western	5.96	1.49	8.87	5.32	4.44	3.55	2.22	1.77	1.33
Pine, Ponderosa	4.85	1.61	7.81	4.69	3.91	3.12	1.95	1.56	1.17
Pine, Sugar	4.95	1.58	7.82	4.68	3.91	3.13	1.96	1.56	1.17
Redwood <sup>D</sup>	6.16	1.25	7.71	4.63	3.85	3.08	1.93	1.54	1.16

<sup>A</sup> For tests conducted in which the wood moisture content is less than or greater than 12 %, the measured strength should be adjusted upward 3 % for each 1 % decrease in moisture content, or downward 3 % for each 1 % increase in moisture content.

<sup>B</sup> For these or other species, values are those for shear parallel to the grain in Test Methods D2555, adjusting to 12 % moisture content using the ratios of dry to green clear wood properties of Test Methods D2555.

<sup>C</sup> Ratio of dry to green strength in Test Methods D2555.

<sup>D</sup> Second growth.

a self-aligning seat to ensure uniform lateral distribution of the load, capable of maintaining a uniform rate of loading in accordance with 10.1, and located in an atmosphere such that the moisture content of the specimens to be tested dry, as developed under the conditions in Section 9, is not significantly altered during testing.

NOTE 5—This testing machine is described in Test Method D905. The shearing tool in Fig. 2 has been found to be satisfactory.

6.6 *Vacuum-Pressure Vessel*, meeting the requirements of 9.2.4 and large enough so that all the specimens are below the water level during the complete cycle.

NOTE 6—The size of the vessel is critical in order to prevent the uppermost specimens from becoming exposed to the air, as water is absorbed by the specimens during treatment.

## TEST METHODS

### 7. Conditioning

7.1 *Measuring Moisture Content*—To measure specimen MC, use Method A (oven dry method) in Methods D2016; or Method B (electronic moisture meter method), when agreement within  $\pm 1$  % MC with Method A has been determined.

#### 7.2 *Conditioning Prior to Testing:*

7.2.1 Before bonding of lumber or cutting the specimens, measure the MC of the laminate joint assemblies at the lumber end with a moisture meter. If the MC is not within the range from 10 to 12 %, use an environmental chamber to bring the assemblies into that range.

#### 7.3 *Specimen Conditioning During the Testing Process*—

The allowable variation in MC at the completion of a drying cycle or before testing dry is  $\pm 1$  % MC. For example, if the MC of the specimen before exposure is 9 %, the acceptable range for testing is 8 to 10 %. Wood failure is estimated on specimens after they have been conditioned to less than 8 %, except for the dry test in 9.1.1 and 9.2.1, where the specimens have never been taken from the dry state. Wood failure may be read on these test specimens following the strength testing, with no further conditioning to reduce MC.

## 8. Material and Preparation of Specimens

### 8.1 *Material:*

8.1.1 *Lumber*—Use lumber that conforms to the following requirements: maximum slope of grain of 1 in 14 on any face or edge; EMC of 8 to 14 %, preferably 10 to 12 %, unless otherwise recommended by the adhesive manufacturer; free of knots and decay; free of machining defects such as chipped grain, dubbed ends, feed-roll polish, coarse knife marks, and feed-roll compression; free of drying effects, such as case hardening, collapse, splits or checks; flat-grain cut; and surfaced on the day the assemblies are to be bonded. See 5.1.2 for species compliance rules relative to testing and Table 3 for information on the bondability of some species of wood.

NOTE 7—Recommended average specific gravities for the various species are given in Table 4. This material is for information only.

8.1.1.1 *Lumber for Laboratory Specimens*—The lumber species to be used for laboratory specimens is Ponderosa Pine.

**TABLE 3 Bondability Groupings of Commonly Used Domestic and Imported Wood<sup>A</sup>**

U.S. Hardwoods	U.S. Softwoods	Imported Woods	
	Group 1—Bond Easily <sup>B</sup> :		
Alder	Cedar, incense	Balsa	Hura
Aspen	Fir:	Cativo	Purpleheart
Basswood	White	Courbaril	Roble
Cottonwood	Grand	Determa <sup>C</sup>	
Chestnut, American	Noble		
Magnolia	Pacific		
Willow, black	Pine:		
	Eastern white		
	Western white		
	Redcedar, western		
	Redwood		
	Spruce, Sitka		
	Group 2—Bond Well <sup>D</sup> :		
Butternut	Douglas-fir	Afrormosia	Meranti (lauan):
Elm:	Larch, western <sup>E</sup>	Andiroba	White
American	Pine:	Angelique	Light red
Rock	Sugar	Avodire	Yellow
Hackberry	Ponderosa	Banak	Obeche
Maple, soft	Redcedar, eastern	Iroko	Okoume
Sweetgum		Jarrah	Opepe
Sycamore		Limba	Peroba rosa
Tupelo		Mahogany:	Sapele
Walnut, black		African	Spanish-cedar
Yellow-poplar		True	Sucupira
			Wallaba
	Group 3—Bond Satisfactorily <sup>F</sup> :		
Ash, white	Alaska-cedar	Angelin	Meranti (lauan), dark red
Beech, American	Port-Orford-cedar	Azobe	Pau marfim
Birch:	Pine, southern	Benge	Parana-pine
Sweet		Bubinga	Pine:
Yellow		Karri	Caribbean
Cherry			Radiata
Hickory:			Ramin
Pecan			
True			
Madrone			
Maple, hard			
Oak:			
Red <sup>C</sup>			
White <sup>C</sup>			
	Group 4—Bond with Difficulty <sup>G</sup> :		
Osage-orange		Balata	Keruing
Persimmon		Balau	Lapacho
		Greenheart	Lignumvitae
		Kaneelhart	Rosewood
		Kapur	Teak

<sup>A</sup> From *Wood Handbook*, 1987 Edition, Table 9-1 (with the species incense cedar added to Group 1) U.S. Forest Service, USDA, Washington, DC. Although this table is of historical significance, it is recognized that more modern adhesives might lead to different species groupings in regard to difficulty of bonding. The user is referred to 5.2.

<sup>B</sup> Bond very easily with adhesives of a wide range of properties and under a wide range of bonding conditions.

<sup>C</sup> Difficult to bond with phenol-formaldehyde adhesive.

<sup>D</sup> Bond well with a fairly wide range of adhesives under a moderately wide range of bonding conditions.

<sup>E</sup> Wood from butt logs with high extractive content are difficult to bond.

<sup>F</sup> Bond satisfactorily with good-quality adhesives under well-controlled bonding conditions.

<sup>G</sup> Satisfactory results require careful selection of adhesives and very close control of bonding conditions; may require special surface treatment.

8.1.2 *Adhesive*—Follow the adhesive manufacturer’s instructions for conditions and procedures when preparing the adhesive and applying it to the stock, and also for assembling, pressing, and curing the assembly.

8.2 *Assemblies*—Prepare the laminate joint assemblies in accordance with Test Method **D905**, except for lumber properties (see 8.1.1).

8.3 *Specimens:*

8.3.1 *Group of Specimens*—See **Table 5** for the number of test specimens required for each performance class.

8.3.2 *Form and Dimension*—Following the prescribed adhesive curing period, cut the laminate joint assemblies into specimens. For the form and dimensions of the laminate joint specimen, see **Fig. 1** and **Fig. 3** with the accompanying table of dimensions.

**9. Exposure Conditions and Treatments**

NOTE 8—Due to the number of specimens to be tested and the type of tests that must be run, there may not be sufficient time to run all the specimens in the time allotted. So that the schedule may be followed, before running the tests in 9.2.2 and 9.2.4, determine whether 1 h is

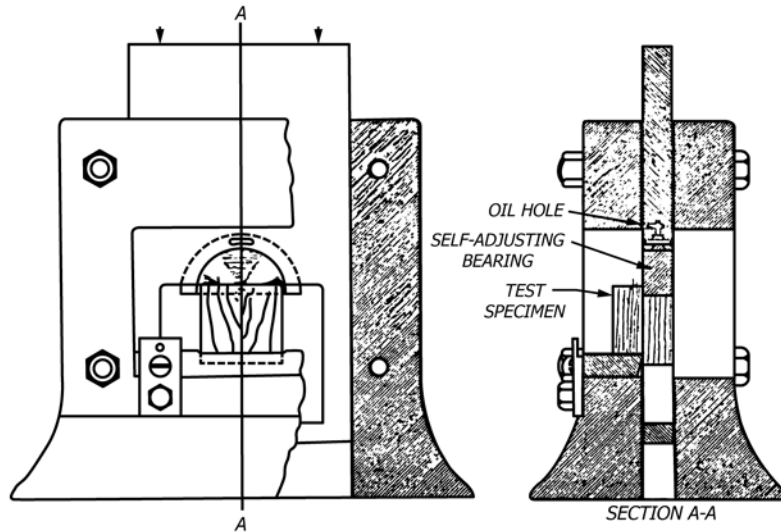

FIG. 2 Shearing Tool

TABLE 4 Recommended Average Specific Gravities by Species

Species	Specific Gravity <sup>A,B,C</sup>
Douglas Fir, East	0.48
Douglas Fir, Interior South	0.46
Cedar, Alaska	0.44
Fir, White	0.39
Hemlock, Western	0.45
Larch, Western	0.52
Pine, Lodgepole	0.41
Pine, Loblolly	0.51
Pine, Ponderosa	0.40

<sup>A</sup> Values have been taken from Table 4-2 in the *Wood Handbook*.<sup>7</sup>

<sup>B</sup> Values are averages based on oven-dry weight and volume at 10 to 12 % moisture content.

<sup>C</sup> The specific gravity for the species used for the test should be the average specific gravity  $\pm 0.03$ .

TABLE 5 Block Shear Tests, Number of Test Specimens

	Dry Use	Wet Use
Total Number of Assemblies	12	16
Total Number of Test Specimens	60	80
Number of Test Specimens per Performance Group <sup>A</sup>	20	20

<sup>A</sup> Required for each unique combination of performance and exposure conditions. (See Table 1.)

enough time to test 20 specimens. If not, divide them into smaller groups before running the exposures. These specimens may be held in a plastic bag to keep them wet during the testing period.

**9.1 Dry Use**—The exposure conditions and treatments to meet the dry-use classification requirements are listed in Table 1. See 7.3 for information on allowable MC when testing the specimens. Details of the test methods are as follows:

**9.1.1 Dry Test**—Test in accordance with instructions in 10.1. See Practice D5266 for guidelines on reading wood failure.

**9.1.2 Soak Test (Three Cycle)**—Place one group of specimens (Table 5), separated by stickers, wire screens, or other means, in such a manner that all surfaces are freely exposed to

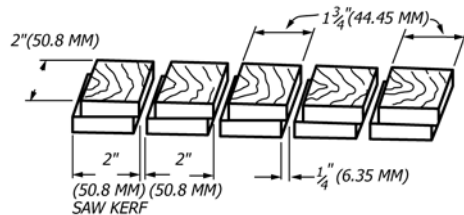

FIG. 3 Test Joint Showing Method of Cutting Five Test Specimens

the water. Weight down the specimens in water at 65 to 80°F (19 to 27°C) so that all specimens are at least 2 in. (50.8 mm) below the surface of the water. Keep the specimens immersed for a period of 4 h, followed by drying at a temperature of 105  $\pm$  5°F (41  $\pm$  3°C) for a period of 19 h, with sufficient air circulation to reduce the moisture content of specimens to within  $\pm 1$  % MC of the original MC as in 7.3. Repeat this procedure twice more for a total of three cycles. Following the third cycle, conduct the tests within 1 h in the dry condition at 75  $\pm$  5°F (24  $\pm$  3°C). If needed, before testing and reading wood failure, condition or dry to less than 8 % MC, in an environmental chamber. (See 7.3.) Use of an electronic moisture meter, as in 7.1, is acceptable to determine MC.

**9.1.3 Elevated Temperature Test:**

**9.1.3.1** Test the specimens for the effect of elevated temperature by using an oven that is capable of heating the specimens to 220  $\pm$  5°F (104  $\pm$  3°C) for 6 h and also capable of enclosing the machine for testing immediately following the exposure period. (See 6.2.)

**9.1.3.2** If an oven to enclose the testing machine is not available, set up the machine close to the oven, remove specimens from the oven one at a time, and test immediately.

**9.2 Wet-Use**—The exposure conditions and treatments to meet the wet-use performance requirements are listed in Table 1, and details are as follows:

**9.2.1 Dry Test**—Follow the instructions in 9.1.1.

**9.2.2 Boil Test**—Place one group of 20 specimens (see Table 5) in a tank of boiling water, separated by stickers, wire

screens, or other means, so that all surfaces are freely exposed to the water. Weight down the specimens and ensure that they are immersed for the duration of the boil cycle. Boil for 4 h. Dry for 20 h at  $145 \pm 5^\circ\text{F}$  ( $63 \pm 3^\circ\text{C}$ ) with sufficient air circulation to lower the MC of the specimens to the original MC, within an allowable variation of  $\pm 1\%$  MC. (See 7.3.) Determine the MC by removing a specimen at 18, 19, and 20 h and test with a moisture meter until the MC reading is in the desired range, or predetermine the time required to reach the desired MC by running samples. Repeat the 4-h boil cycle. Then remove the specimens and cool in running water at  $65$  to  $80^\circ\text{F}$  ( $18$  to  $27^\circ\text{C}$ ) for 1 h. Remove the specimens from the water, place in a plastic bag to prevent them from drying, and test while wet within 1 h.

9.2.2.1 Dry the specimens to less than 8 % MC and estimate the percentage of wood failure. (See 7.3.)

9.2.3 *Elevated Temperature Test*—Follow the instructions in 9.1.3.

9.2.4 *Vacuum-Pressure Test*—Place one group of specimens (Table 5) in a pressure vessel, separated by stickers, wire screens, or other means in such a manner that all surfaces can be freely exposed to the water. Weight down the specimens and fill the vessel with water at  $65$  to  $80^\circ\text{F}$  ( $18$  to  $27^\circ\text{C}$ ), and ensure that all specimens are immersed for the duration of the exposure cycle. Draw and maintain a vacuum of at least 25 in. Hg (84.4 kPa) for 30 min. Release the vacuum, and follow immediately with pressure application of  $75 \pm 2$  psi ( $517 \pm 14$  kPa) for 30 min. Remove the specimens from the water, place in a plastic bag to prevent them from drying, and test while wet within 1 h. Dry the broken specimens to less than 8 % MC and estimate the percentage of wood failure. (See 7.3.)

## 10. Testing and Calculation

10.1 *Testing*—With a shear tool of the type in 6.5, apply the load through a self-aligning seat to ensure uniform lateral distribution of the load and with a continuous motion of the movable head at a rate of 0.5 in. (12.8 mm)/min  $\pm 10\%$ .

10.2 *Determination of Average Wood Species Strength*—Use Table 2 to obtain the average shear strength at 12 % MC for any species appearing on the tables. See Footnote A in Table 2 for information on adjusting for MC of the lumber. For species not appearing on the table, refer first to Test Methods D2555, and if necessary, to the Forest Product Laboratories *Wood Handbook*, latest edition. For any species not appearing in the above three sources, determine the average species strength by the instructions given in Test Methods D2555. Also, obtain information from Table 2 or the publications listed, as to whether the species should be classified as softwood or hardwood.

10.2.1 Enter the average species strength on Fig. X1.3 in the space provided. This line is marked with an asterisk.

## 10.3 Calculation and Data Entry:

10.3.1 Measure the bond line dimensions to the nearest 0.06 in. (6.45 mm). Calculate the shear stress at failure in pounds-force per square inch or megapascals, based on the specimen's breaking load and the tested bond line area.

10.3.2 Enter the shear stress at failure in psi or MPa for the 20 specimens for each test on Fig. X1.1 and Fig. X1.2. Also, place a check (X) alongside the individual specimen value that is the minimum.

10.3.3 Transfer the average strength and individual minimum strength for each test from Fig. X1.1 and Fig. X1.2 to Fig. X1.3, Columns D and G, respectively. For Columns C and F calculate the required average specimen strength and the required individual minimum strength respectively, for each test.

10.3.4 Determine if the test requirements given in Columns C and F are met.

10.4 On Fig. X1.1 and Fig. X1.2, enter the individual and average percent wood failure for the 20 specimens for each test using Practice D5266 to estimate the wood failure. Also, place a check (X) alongside the minimum individual percent wood failure. Transfer the average and minimum wood failure values for each test to Fig. X1.4, using the appropriate category, softwood or hardwood. Determine if the average and minimum test values entered in columns "H" and "L" meet the requirements in columns "J" and "K" for softwood or "M" and "N" for hardwood.

## 11. Report

11.1 Using the report forms, Fig. X1.1 and Fig. X1.2, and the summary report forms, Fig. X1.3 and Fig. X1.4, report the following:

11.1.1 The wood species used, average strength of the species, and source of the information.

11.1.2 The strength at failure for the individual specimen, average, and individual minimum for each test.

11.1.3 The percent wood failure for the individual specimen, average, and individual minimum for each test.

11.1.4 The pass/fail status of the test adhesive.

## 12. Precision and Bias

12.1 The precision and bias of exposure condition tests in Specification D5751 for the determination of the Performance Classification of the adhesive has not been determined yet. A round robin format is being developed and it is expected that results will be available by August 2002.

## 13. Keywords

13.1 bonded; dry-use-nonstructural adhesive; edge joint; face joint; laminate joint; nonstructural lumber; wet-use adhesive

**APPENDIX**

**(Nonmandatory Information)**

**X1. REPORT FORMS**

X1.1 The report forms in Figs. X1.1-X1.4 are used to record test results and to provide an easy reference to determine whether the specimens prepared with the test adhesive pass the requirements of this specification:

SPECIFICATION D 5751 REPORT FORM		LAMINATE JOINT		DRY USE		
Adhesive Manufacturer _____		Hardwood Species _____		Softwood _____		
Testing Facility _____		_____		_____		
Laboratory No. _____		_____		_____		
Type Test >>>	Dry (9.1.1)	2-Cycle Soak (9.1.2)		220°F(104°C) (9.1.3)		
Specimen No.	Strength psi/MPa	Wood Failure %	Strength psi/MPa	Wood Failure %	Strength psi/MPa	Wood Failure %
For each test, place a check (X) alongside the minimum strength and the minimum % wood failure	1	_____	_____	_____	_____	_____
	2	_____	_____	_____	_____	_____
	3	_____	_____	_____	_____	_____
	4	_____	_____	_____	_____	_____
	5	_____	_____	_____	_____	_____
	6	_____	_____	_____	_____	_____
	7	_____	_____	_____	_____	_____
	8	_____	_____	_____	_____	_____
	9	_____	_____	_____	_____	_____
	10	_____	_____	_____	_____	_____
	11	_____	_____	_____	_____	_____
	12	_____	_____	_____	_____	_____
	13	_____	_____	_____	_____	_____
	14	_____	_____	_____	_____	_____
	15	_____	_____	_____	_____	_____
	16	_____	_____	_____	_____	_____
	17	_____	_____	_____	_____	_____
18	_____	_____	_____	_____	_____	
19	_____	_____	_____	_____	_____	
20	_____	_____	_____	_____	_____	
A Avg Strength	_____	XXX	_____	XXX	_____	XXX
B Average % WF	XXX	_____	XXX	_____	XXX	_____
A Transfer Avg and Min strengths to the X1.3 Summary Report Form.						
B Transfer the Avg and Min % WF to the Hardwood or Softwood blanks in the X1.4 Summary Report Form.						
Adhesive used _____		Adhesive mix, spread, pressing conditions and comments _____		Plant temperature _____		
Date glued _____		_____		Recommended aging period _____		
Date received _____		_____		Date testing started _____		
Tested by _____		_____		Test Specimens _____		
_____		_____		Shear area _____ × 1.5 in.		
_____		_____		Dry sheared at _____ % MC		

**FIG. X1.1 Report Form for Laminate Joint, Dry Use**





D5751 – 99 (2012)

SPECIFICATION D 5751 REPORT FORM

LAMINATE JOINT WET USE

Adhesive Manufacturer \_\_\_\_\_
Testing Facility \_\_\_\_\_
Laboratory No. \_\_\_\_\_

Hardwood \_\_\_\_\_ Softwood \_\_\_\_\_
Species \_\_\_\_\_

Table with columns: Type Test >>>, Dry (9.2.1), Boil (9.2.2), 220°F(104°C) (9.2.3), Vac. Press. (9.2.4). Rows include specimen numbers 1-20 and summary rows A and B.

A Transfer Avg and Min strengths to the X1.3 Summary Report Form.
B Transfer the Avg and Min WF % to the Hardwood or Softwood blank in the X1.4 Report Form.

Adhesive used \_\_\_\_\_
Date received \_\_\_\_\_
Tested by \_\_\_\_\_

Adhesive mix, spread,
comments \_\_\_\_\_

Plant temperature \_\_\_\_\_
Date testing started \_\_\_\_\_
Test Specimens
Shear area \_\_\_\_\_ x 1.5 in.
Dry sheared at \_\_\_\_\_ % MC

FIG. X1.2 Report Form for Laminate Joint, Wet Use

SPECIFICATION D 5751  
SUMMARY REPORT FORM

STRENGTH TEST RESULTS AND CALCULATIONS  
LAMINATE JOINT

Hardwood \_\_\_\_\_ Softwood \_\_\_\_\_ Laboratory No. \_\_\_\_\_  
 Average Species Strength \_\_\_\_\_ (psi or MPa) Source of Avg Species Strength \_\_\_\_\_  
 (Transfer Avg Species Strength to all lines of column A below.)

Calculations, Shear Strength Requirements

Test	A	B	C	D	A	E	F	G
	Average Species Strength	Required Average Strength as %	Required Average Specimen Strength	Average Strength of Test Specimens	Average Species Strength	Required Individual Minimum Strength	Required Individual Minimum Strength	Individual Minimum Strength (Specimen)
No.	psi or MPa	of "A"	psi or MPa	psi or MPa	psi or MPa	% of "A"	psi or MPa	psi or MPa
Dry Use								
9.1.1	_____	x 60%	= _____	_____	_____	x 30%	= _____	_____
9.1.2	_____	x 30%	= _____	_____	_____	x 15%	= _____	_____
9.1.3	_____	x 40%	= _____	_____	_____	x 20%	= _____	_____
Wet Use								
9.2.1	_____	x 60%	= _____	_____	_____	x 30%	= _____	_____
9.2.2	_____	x 50%	= _____	_____	_____	x 25%	= _____	_____
9.2.3	_____	x 40%	= _____	_____	_____	x 20%	= _____	_____
9.2.4	_____	x 50%	= _____	_____	_____	x 25%	= _____	_____

Meets Dry and Wet Use Strength Requirements Yes \_\_\_ No \_\_\_

The descriptions of the column headings are given below:

- A The average strength of the wood species used for the tests. Enter this value in all lines of the 2 columns labeled "A". Refer to Table 4 of this specification, Standard D 2555, or Forest Products Laboratory Handbook, latest edition. Refer to Footnote "A" in Table 4 for instructions on adjusting for MC.
- B The required average strength as % of "A", taken from Table 1.
- C The required average strength converted to psi or MPa.
- D The average test strengths taken from Fig.'s X1.1 and X1.2. These values must meet or exceed the requirements in column "C".
- E The required individual minimum strength as % of "A" taken from Table 1.
- F The required individual minimum strength converted to psi or MPa.
- G The individual minimum test strengths taken from Fig's. X1.1 and X1.2. These values must meet or exceed the requirements in column "F". See Table 1 (Footnote F).

**FIG. X1.3 Report Form for Strength Test Results and Calculations, Laminate Joint**

SPECIFICATION D 5751 SUMMARY REPORT FORM  
WOOD FAILURE TEST RESULTS, LAMINATE JOINT

Softwood \_\_\_\_\_ Hardwood \_\_\_\_\_ Laboratory No. \_\_\_\_\_

Wood Failure Test Results and  
Average and Minimum Wood Failure Percent Requirements

	Softwood			Hardwood		
	H Value Avg/Min WF%	J Required Average WF%	K Required Minimum WF%	L Value Avg/Min WF%	M Required Average WF%	N Required Minimum WF%
Dry Use						
9.1.1	_____	60	30	_____	30	15
9.1.2	_____	30	15	_____	15	None
9.1.3	_____	40	20	_____	20	None
Wet Use						
9.2.1	_____	60	30	_____	30	15
9.2.2	_____	50	25	_____	25	None
9.2.3	_____	40	20	_____	20	None
9.2.4	_____	50	25	_____	25	None

Meets Dry Use and Wet Use Wood Failure Requirements Yes \_\_\_ No \_\_\_

The descriptions of the column headings are given below:

- H & L Entry columns for average % wood failure from Fig.'s X1.1 and X1.2.
- J & M Required average % wood failure. See Table 1 (Footnote E).
- K & N Required minimum % wood failure. See Table 1 (Footnote F).

**FIG. X1.4 Report Form for Wood Failure Test Results, Laminate Joint**

 **D5751 – 99 (2012)**

*ASTM International takes no position respecting the validity of any patent rights asserted in connection with any item mentioned in this standard. Users of this standard are expressly advised that determination of the validity of any such patent rights, and the risk of infringement of such rights, are entirely their own responsibility.*

*This standard is subject to revision at any time by the responsible technical committee and must be reviewed every five years and if not revised, either reapproved or withdrawn. Your comments are invited either for revision of this standard or for additional standards and should be addressed to ASTM International Headquarters. Your comments will receive careful consideration at a meeting of the responsible technical committee, which you may attend. If you feel that your comments have not received a fair hearing you should make your views known to the ASTM Committee on Standards, at the address shown below.*

*This standard is copyrighted by ASTM International, 100 Barr Harbor Drive, PO Box C700, West Conshohocken, PA 19428-2959, United States. Individual reprints (single or multiple copies) of this standard may be obtained by contacting ASTM at the above address or at 610-832-9585 (phone), 610-832-9555 (fax), or [service@astm.org](mailto:service@astm.org) (e-mail); or through the ASTM website ([www.astm.org](http://www.astm.org)). Permission rights to photocopy the standard may also be secured from the Copyright Clearance Center, 222 Rosewood Drive, Danvers, MA 01923, Tel: (978) 646-2600; <http://www.copyright.com/>*