



# Standard Test Methods for Determination of Nickel, Vanadium, and Iron in Crude Oils and Residual Fuels by Inductively Coupled Plasma (ICP) Atomic Emission Spectrometry<sup>1</sup>

This standard is issued under the fixed designation D5708; the number immediately following the designation indicates the year of original adoption or, in the case of revision, the year of last revision. A number in parentheses indicates the year of last reapproval. A superscript epsilon ( $\epsilon$ ) indicates an editorial change since the last revision or reapproval.

## 1. Scope\*

1.1 These test methods cover the determination of nickel, vanadium, and iron in crude oils and residual fuels by inductively coupled plasma (ICP) atomic emission spectrometry. Two different test methods are presented.

1.2 *Test Method A (Sections 7 – 11 and 18 – 22)*—ICP is used to analyze a sample dissolved in an organic solvent. This test method uses oil-soluble metals for calibration and does not purport to quantitatively determine or detect insoluble particulates.

1.3 *Test Method B (Sections 12 – 22)* —ICP is used to analyze a sample that is decomposed with acid.

1.4 The concentration ranges covered by these test methods are determined by the sensitivity of the instruments, the amount of sample taken for analysis, and the dilution volume. A specific statement is given in 15.2. Typically, the low concentration limits are a few tenths of a milligram per kilogram. Precision data are provided for the concentration ranges specified in Section 21.

1.5 The values stated in SI units are to be regarded as standard.

1.5.1 *Exception*—The values given in parentheses are for information only

1.6 *This standard does not purport to address all of the safety concerns, if any, associated with its use. It is the responsibility of the user of this standard to establish appropriate safety and health practices and determine the applicability of regulatory limitations prior to use.*

<sup>1</sup> These test methods are under the jurisdiction of ASTM Committee D02 on Petroleum Products, Liquid Fuels, and Lubricants and is the direct responsibility of Subcommittee D02.03 on Elemental Analysis.

Current edition approved Dec. 1, 2015. Published December 2015. Originally approved in 1995. Last previous edition approved in 2012 as D5708 – 12<sup>ε</sup>. DOI: 10.1520/D5708-15.

## 2. Referenced Documents

### 2.1 ASTM Standards:<sup>2</sup>

D1193 Specification for Reagent Water

D1548 Test Method for Vanadium in Heavy Fuel Oil<sup>1</sup> (Withdrawn 1997)<sup>3</sup>

D4057 Practice for Manual Sampling of Petroleum and Petroleum Products

D4177 Practice for Automatic Sampling of Petroleum and Petroleum Products

D5185 Test Method for Multielement Determination of Used and Unused Lubricating Oils and Base Oils by Inductively Coupled Plasma Atomic Emission Spectrometry (ICP-AES)

D6299 Practice for Applying Statistical Quality Assurance and Control Charting Techniques to Evaluate Analytical Measurement System Performance

D7260 Practice for Optimization, Calibration, and Validation of Inductively Coupled Plasma-Atomic Emission Spectrometry (ICP-AES) for Elemental Analysis of Petroleum Products and Lubricants

## 3. Summary of Test Method

3.1 *Test Method A*—Approximately 10 g of the sample are dissolved in an organic solvent (**Warning**—Combustible. Vapor is harmful.) to give a specimen solution containing 10 % (m/m) of sample. The solution is nebulized into the plasma, and the intensities of the emitted light at wavelengths characteristic of the analytes are measured sequentially or simultaneously. The intensities are related to concentrations by the appropriate use of calibration data.

<sup>2</sup> For referenced ASTM standards, visit the ASTM website, www.astm.org, or contact ASTM Customer Service at service@astm.org. For *Annual Book of ASTM Standards* volume information, refer to the standard's Document Summary page on the ASTM website.

<sup>3</sup> The last approved version of this historical standard is referenced on www.astm.org.

\*A Summary of Changes section appears at the end of this standard

3.2 *Test Method B*—One to 20 g of sample are weighed into a beaker and decomposed with concentrated sulfuric acid (**Warning**—Poison. Causes severe burns. Harmful or fatal if swallowed or inhaled.) by heating to dryness. Great care must be used in this decomposition because the acid fumes are corrosive and the mixture is potentially flammable. The residual carbon is burned off by heating at 525 °C in a muffle furnace. The inorganic residue is digested with nitric acid (**Warning**—Poison. Causes severe burns. Harmful or fatal if swallowed or inhaled.), evaporated to incipient dryness, dissolved in dilute nitric acid, and made up to volume. The solution is nebulized into the plasma of an atomic emission spectrometer. The intensities of light emitted at characteristic wavelengths of the metals are measured sequentially or simultaneously. These intensities are related to concentrations by the appropriate use of calibration data.

#### 4. Significance and Use

4.1 These test methods cover, in single procedures, the determination of Ni, V, and Fe in crude oils and residual oils. These test methods complement Test Method D1548, which covers only the determination of vanadium.

4.2 When fuels are combusted, vanadium present in the fuel can form corrosive compounds. The value of crude oils can be determined, in part, by the concentrations of nickel, vanadium, and iron. Nickel and vanadium, present at trace levels in petroleum fractions, can deactivate catalysts during processing. These test methods provide a means of determining the concentrations of nickel, vanadium, and iron.

#### 5. Purity of Reagents

5.1 Reagent grade chemicals shall be used in all tests. Unless otherwise indicated, it is intended that all reagents conform to the specifications of the Committee on Analytical Reagents of the American Chemical Society where such specifications are available.<sup>4</sup> Other grades may be used, provided it is first ascertained that the reagent is of sufficiently high purity to permit its use without lessening the accuracy of the determination.

5.2 When determining metals at concentrations less than 1 mg/kg, use ultra-pure reagents.

5.3 *Purity of Water*—Unless otherwise indicated, reference to water shall be understood to mean reagent water conforming to Type II of Specification D1193.

#### 6. Sampling and Sample Handling

6.1 The objective of sampling is to obtain a sample for testing purposes that is representative of the entire quantity. Thus, take samples in accordance with the instructions in Practice D4057 or D4177. Do not fill the sample container more than two-thirds full.

<sup>4</sup> *Reagent Chemicals, American Chemical Society Specifications*, American Chemical Society, Washington, DC. For Suggestions on the testing of reagents not listed by the American Chemical Society, see *Annual Standards for Laboratory Chemicals*, BDH Ltd., Poole, Dorset, U.K., and the *United States Pharmacopeia and National Formulary*, U.S. Pharmacopeial Convention, Inc. (USPC), Rockville, MD.

6.2 Prior to weighing, stir the sample and manually shake the sample container. If the sample does not readily flow at room temperature, heat the sample in a drying oven at 80°C or at another safe temperature.

### TEST METHOD A— ICP WITH AN ORGANIC SOLVENT SPECIMEN SOLUTION

#### 7. Apparatus

7.1 *Inductively Coupled Plasma Atomic Emission Spectrometer*—Either a sequential or simultaneous spectrometer, equipped with a quartz torch and radio-frequency generator to form and sustain the plasma, is suitable.

7.2 *Nebulizer*—The use of a *high-solids* nebulizer is optional but strongly recommended. This type of nebulizer minimizes the probability of clogging. A concentric glass nebulizer can also be used.

7.3 *Peristaltic Pump*—This pump is required for non-aspirating nebulizers and optional for aspirating nebulizers. The pump must achieve a flow rate in the range of 0.5 mL/min to 3 mL/min. The pump tubing must be able to withstand at least a 6 h exposure to the solvent. Fluoroelastomer copolymer tubing is recommended.<sup>5</sup>

7.4 *Specimen Solution Containers*, glass or plastic vials or bottles with screw caps having a capacity of appropriate size. One hundred millilitre glass bottles are satisfactory.

#### 8. Reagents

8.1 *Dilution Solvent*—Mixed xylenes, *o*-xylene, tetralin and mixed paraffin-aromatic solvents are satisfactory. Solvent purity can affect analytical accuracy when the sample contains low concentrations (typically, a few milligrams per kilogram) of the analytes.

8.2 *Mineral Oil*—A high-purity oil such as U.S.P. white oil.

8.3 *Organometallic Standards*—Pre-prepared multielement concentrates containing 100 mg/kg concentrations of each element are satisfactory.

8.4 *Quality Control (QC) Samples*, preferably are portions of one or more liquid petroleum materials that are stable and representative of the samples of interest. These QC samples can be used to check the validity of the testing process as described in Section 19.

#### 9. Preparation of Standards and Specimens

9.1 *Blank*—Prepare a blank by diluting mineral oil with dilution solvent. The concentration of mineral oil must be 10 % (m/m). Mix well.

9.2 *Check Standard*—Using organometallic standards, mineral oil, and dilution solvent, prepare a check standard to contain analyte concentrations approximately the same as expected in the specimens. The concentration of oil in the check standard must be 10 % (m/m).

<sup>5</sup> Fluoroelastomer copolymer is manufactured as Viton, a trademark owned by E. I. duPont de Nemours.

9.3 *Test Specimen*—Weigh a portion of well-mixed sample into a container and add sufficient solvent to achieve a sample concentration of 10 % (m/m). Mix well.

9.4 *Working Standard*—Prepare an instrument calibration standard that contains 10 mg/kg each of vanadium, nickel, and iron. Combine the organometallic standard, dilution solvent and, if necessary, mineral oil so that the oil content of the calibration standard is 10 % (m/m).

9.5 *Quality Control (QC) Samples*—Weigh a portion of the well-mixed QC sample into a container and add sufficient solvent to achieve a sample concentration of 10 % (m/m).

## 10. Preparation of Apparatus

10.1 Consult Practice **D7260** regarding the optimum operation of any ICP-AES system.

10.2 Consult the manufacturer’s instructions for the operation of the ICP instrument. This test method assumes that good operating procedures are followed. Design differences between instruments make it impractical to specify required parameters.

10.3 Assign the appropriate operating parameters to the instrument taskfile so that the desired analytes can be determined. Parameters include: (1) element, (2) analytical wavelength, (3) background correction wavelengths (optional), (4) interelement correction factors (refer to **10.4**), (5) integration time of 1 to 10 s, (6) two to five consecutive repeat integrations. Suggested wavelengths are listed in **Table 1**.

10.4 *Spectral Interferences*—Check all spectral interferences expected for the analytes. If interference corrections are necessary, follow the manufacturer’s operating guide to develop and apply correction factors.

10.4.1 Spectral interferences can usually be avoided by judicious choice of analytical wavelengths. If spectral interferences cannot be avoided, the necessary corrections should be made using the computer software supplied by the instrument manufacturer or by using the empirical method described in Test Method **D5185**.

10.5 Consult the instrument manufacturer’s instructions for operating the instrument with organic solvents.

10.6 During instrument warm-up, nebulize the blank solution. Inspect the torch for carbon build-up. When carbon build-up occurs, replace the torch and adjust the operating conditions to correct the problem.

10.6.1 Carbon build-up within the torch can be caused by improperly adjusted argon flow rates, improper solution flow rates, and positioning the torch injector tube too close to the

load coil. Carbon deposits can invalidate a calibration and extinguish the plasma.

## 11. Calibration and Analysis

11.1 Using the blank and working standard, perform a two-point calibration at the beginning of the analysis of each batch of specimens. Additional working standards can be used, if desired.

11.2 Use the check standard to determine if the calibration for each analyte is accurate. When the result obtained on the check standard is not within  $\pm 5\%$  of the expected concentration for each analyte, take corrective action and repeat the calibration.

11.3 Analyze the specimens in the same manner as the calibration standards (that is, same integration time, plasma conditions, and so forth). Calculate concentrations by multiplying the concentration determined for the test specimen solution by the dilution factor. Calculation of concentrations can be performed manually or by computer when such a feature is available.

11.4 When the measured intensities for the test specimen solution exceed the corresponding intensities for the working standard, either ensure that the calibration curve is linear to the concentration of the element in the test specimen solution or dilute the test specimen solution with the blank solution and reanalyze.

11.5 Analyze the check standard after every fifth specimen. If any result is not within 5 % of the expected concentration, take corrective action, repeat the calibration, and reanalyze the specimen solutions back to the previous acceptable check standard analysis.

11.6 The use of spectral background correction is highly recommended, particularly when the test specimen solutions contain low concentrations of the analytes (typically less than 1 mg/kg). When concentrations are low, background changes, which can result from variability in the compositions of test specimen solutions, can affect the accuracy of the analysis. Background correction minimizes errors due to variable background intensities.

## TEST METHOD B— ICP AFTER ACID DECOMPOSITION OF SAMPLE

### 12. Apparatus

12.1 Refer to **7.1 – 7.4**.

12.2 *Sample Decomposition Apparatus (optional)*—This apparatus is shown in **Fig. 1**. It consists of a high-silica or borosilicate 400 mL beaker for the specimen, an air bath (**Fig. 2**) that rests on a hot plate, and a 250 watt infrared lamp supported 1 in. above the air bath. A variable transformer controls the voltage applied to the lamp.

12.3 *Glassware*, high-silica or borosilicate 400 mL beakers, volumetric flasks of various capacities, and pipettes of various capacities. All glassware used in this test method must be thoroughly cleaned and rinsed with water.

**TABLE 1 Elements Determined and Suggested Wavelengths**

NOTE 1—These wavelengths are suggestions and do not represent all possible choices.<sup>A</sup>

Element	Wavelength, nm
Iron	259.94, 238.20
Nickel	231.60, 216.56
Vanadium	292.40, 310.22

<sup>A</sup> Winge, R. K., Fassel, V. A., Peterson, V. J., and Floyd, M. A., *Inductively Coupled Plasma Atomic Emission Spectroscopy: An Atlas of Spectral Information*, Elsevier, NY, 1985.

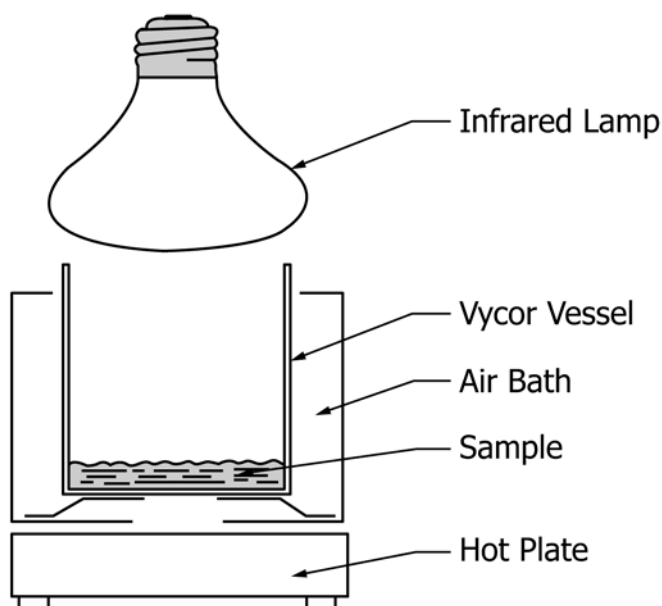

FIG. 1 Decomposition Apparatus

12.4 *Electric Muffle Furnace*, capable of maintaining  $525\text{ }^{\circ}\text{C} \pm 25\text{ }^{\circ}\text{C}$  and sufficiently large to accommodate 400 mL beakers. The capability of an oxygen bleed is advantageous and optional.

12.5 *Steam Bath (optional)*.

12.6 *Temperature Controlled Hot Plate (optional)*.

### 13. Reagents

13.1 *Aqueous Standard Solutions*, individual aqueous standards with 1000 mg/L concentrations of vanadium, nickel, and iron.

13.2 *Nitric Acid*, concentrated nitric acid,  $\text{HNO}_3$ .

13.3 *Nitric Acid (1 + 1)*—Carefully add, with stirring, one volume of concentrated nitric acid to one volume of water.

13.4 *Dilute Nitric Acid (19 + 1)*—Carefully add, with stirring, one volume of concentrated nitric acid to 19 volumes of water.

13.5 *Sulfuric Acid*, concentrated sulfuric acid,  $\text{H}_2\text{SO}_4$ .

### 14. Preparation of Standards and Quality Control (QC) Samples

14.1 *Blank Standard*—Dilute (19 + 1) nitric acid.

14.2 *Multi-element Standard*—Using the aqueous standard solutions, prepare a multi-element standard containing 100 mg/L each of vanadium, nickel, and iron.

14.3 *Working Standard*—Dilute the multi-element standard ten-fold with dilute nitric acid.

14.4 *Check Standards*—Prepare calibration check standards in the same way as the working standard and at analyte concentrations that are typical of the samples being analyzed.

14.5 *Quality Control (QC) Samples*—Follow Section 15 using the QC samples as test specimens.

### 15. Preparation of Test Specimens

15.1 Into a beaker, weigh an amount of sample estimated to contain between 0.0025 mg and 0.12 mg of each metal to be determined. A typical mass is 10 g. Add 0.5 mL of  $\text{H}_2\text{SO}_4$  for each gram of sample.

NOTE 1—If it is desirable to extend the lower concentration limits of the method, it is recommended that the decompositions be done in 10 g increments up to a maximum of 100 g. It is not necessary to destroy all the organic matter each time before adding additional amounts of sample and acid. When it is desirable to determine higher concentrations, reduce the sample size accordingly.

15.2 At the same time, prepare reagent blanks using the same amount of sulfuric acid as used for sample decomposition. Perform all steps specified in this section. (**Warning**—Reagent blanks are critical when determining concentrations below 1 mg/kg. To simplify the analysis, use the same volume of acid and the same dilutions as used for the samples. For example, if 20 g of sample is being decomposed, use 10 mL of sulfuric acid for the reagent blank.)

15.3 The use of the air bath apparatus (Fig. 2) to minimize sample spattering and foaming is optional. Place the beaker in the air bath, which is located in a hood. The hot plate is off at this time. Heat gently from the top with the infrared lamp (Fig. 1) while stirring the specimen with a glass rod. As decomposition proceeds (indicated by a frothing and foaming), control the heat of the infrared lamp to maintain steady evolution of fumes. Give constant attention to each sample mixture until all risk of spattering and foaming is past. Then, gradually increase the temperatures of both the hot plate and lamp until the sample is reduced to a carbonaceous ash.

15.4 If the air bath apparatus is not used, heat the sample and acid on a temperature controlled hot plate. As described in 15.3, monitor the decomposition reaction and adjust the temperature of the hot plate accordingly. (**Warning**—Hot, fuming, concentrated sulfuric acid is a very strong oxidizing acid. The analyst should work in a well-ventilated hood and wear rubber gloves and a suitable face shield to protect against spattering acid.)

15.5 Place the sample in a muffle furnace maintained at  $525\text{ }^{\circ}\text{C} \pm 25\text{ }^{\circ}\text{C}$ . Optionally, introduce a gentle stream of oxygen into the furnace to expedite oxidation. Continue to heat until the carbon is completely removed.

15.6 Dissolve the inorganic residue by washing down the wall of the beaker with about 10 mL of 1 + 1  $\text{HNO}_3$ . Digest on a steam bath for 15 to 30 min. Transfer to a hot plate and gently evaporate to incipient dryness.

15.7 Wash down the wall of the beaker with about 10 mL of dilute nitric acid. Digest on the steam bath until all salts are dissolved. Allow to cool. Transfer quantitatively to a volumetric flask of suitable volume and make up to volume with dilute nitric acid. This is the specimen solution.

### 16. Preparation of Apparatus

16.1 Refer to 10.2 – 10.4.

### 17. Calibration and Analysis

17.1 Refer to Section 11.

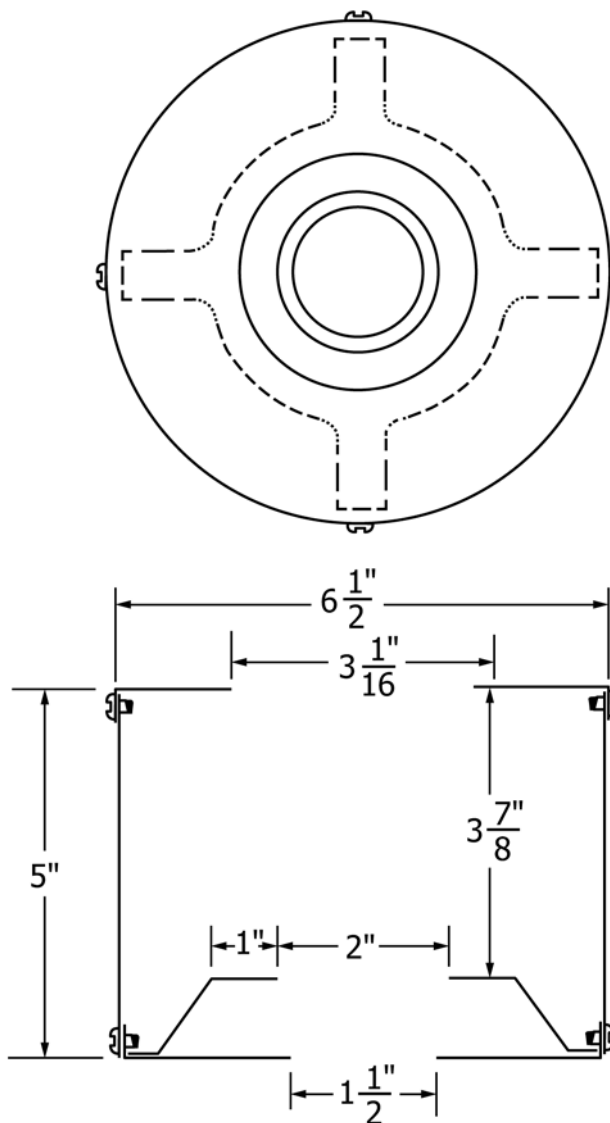

NOTE 1—All parts are 16-gauge (0.060 in., 1.5 mm) aluminum. All dimensions are in inches.

Metric Equivalents			
in.	mm	in.	mm
1	25.4	3 7/8	98.4
1 1/2	38.1	5	127
2	50.8	6 1/2	165.1
3 1/16	77.8		

FIG. 2 Air Bath

17.2 Analyze the reagent blank (refer to 15.2) and correct the results obtained on the test specimen solutions by subtracting the reagent blank results.

### 18. Calculations

18.1 For Test Method A, calculate the concentration of each analyte in the sample using the following equation:

$$\text{analyte concentration, mg/kg} = C \times F \quad (1)$$

where:

- $C$  = concentration of the analyte in the specimen solution, mg/kg, and
- $F$  = dilution factor.

**TABLE 2 Repeatability**

NOTE 1—X = mean concentration, mg/kg.

Element	Concentration Range, mg/kg	Test Method	Repeatability, mg/kg
Vanadium	50–500	A	0.07X <sup>0.88</sup>
		B	0.02X <sup>1.1</sup>
Nickel	10–100	A	0.01X <sup>1.3</sup>
		B	0.02X <sup>1.2</sup>
Iron	1–10	A	0.22X <sup>0.30</sup>
		B	0.23X <sup>0.67</sup>

18.2 For Test Method B, calculate the concentration of each analyte in the sample using the following equation:

$$\text{analyte concentration, mg/kg} = (C \times V \times F)/W \quad (2)$$

where:

*C* = concentration of the analyte in the specimen solution (corrected for the concentration determined in the reagent blank), mg/L

*V* = volume of the specimen solution, mL,

*F* = dilution factor, and

*W* = sample mass, g.

## 19. Quality Control

19.1 Confirm the performance of the test procedure by analyzing a quality control (QC) sample (9.5 for Test Method A or 14.5 for Test Method B).

19.1.1 When QC/Quality Assurance (QA) protocols are already established in the testing facility, these may be used to confirm the reliability of the test result.

19.1.2 When there is no QC/QA protocol established in the testing facility, Appendix X1 can be used as the QC/QA system.

## 20. Report

20.1 Report concentrations in milligrams per kilogram to three significant figures.

## 21. Precision and Bias<sup>6</sup>

21.1 *Precision*—The precision of these test methods was determined by statistical analysis of interlaboratory test results.

<sup>6</sup> Supporting data have been filed at ASTM International Headquarters and may be obtained by requesting Research Report RR:D02-1351.

For Test Method A, eleven cooperators participated in the interlaboratory study. Mixed xylenes, *o*-xylene, and tetralin were successfully used as dilution solvents. One cooperator noted that when kerosine was used, a precipitate developed in several minutes. All cooperators used a peristaltic pump. Approximately half of the cooperators used a high-solids nebulizer. Approximately half of the cooperators used background correction. For Test Method B, eight cooperators participated in the interlaboratory study. All labs but one used a peristaltic pump. Most labs did not use a high-solids nebulizer. Approximately half of the labs used background correction. Seven samples (four residual oils and three crude oils) comprised the test set. One residual oil was NIST SRM 1618,<sup>7</sup> and one crude oil was NIST RM 8505.<sup>7</sup>

21.1.1 *Repeatability*—The difference between two test results, obtained by the same operator with the same apparatus under constant operating conditions on identical test materials would, in the long run, in the normal and correct operation of the test method, exceed the values in Table 2 and Table 3 only in one case in twenty.

21.1.2 *Reproducibility*—The difference between two single and independent results, obtained by different operators working in different laboratories on identical test materials would, in the long run, in the normal and correct operation of the test method, exceed the values in Table 4 and Table 5 only in one case in twenty.

21.2 *Bias*—Bias was evaluated from results obtained on two NIST samples. For Test Methods A and B, the means of the reported values for V and Ni do not differ from the corresponding expected values by more than the repeatability of the test method. Standard reference materials for Fe are not available, so bias was not determined.

## 22. Keywords

22.1 emission spectrometry; ICP; inductively coupled plasma atomic emission spectrometry; iron; nickel; vanadium

<sup>7</sup> Available from National Institute of Standards and Technology (NIST), 100 Bureau Dr., Stop 3460, Gaithersburg, MD 20899-3460.

**TABLE 3 Calculated Repeatability (mg/kg) at Selected Concentrations (mg/kg)**

Element	Test Method	Concentration				
		1	10	50	100	500
Vanadium	A	...	...	2.2	4.0	17
	B			1.5	3.2	19
Nickel	A	...	0.20	1.6	4.0	...
	B		0.32	2.2	5.0	
Iron	A	0.22	0.44	...	...	...
	B	0.23	1.08			

**TABLE 4 Reproducibility**

NOTE 1— $X$  = mean concentration, mg/kg.

Element	Concentration Range, mg/kg	Test Method	Reproducibility, mg/kg
Vanadium	50–500	A	$0.12X^{1.1}$
		B	$0.10X^{1.1}$
Nickel	10–100	A	$0.41X^{0.78}$
		B	$0.05X^{1.3}$
Iron	1–10	A	$0.68X^{0.35}$
		B	$0.91X^{0.51}$

**TABLE 5 Calculated Reproducibility (mg/kg) at Selected Concentrations (mg/kg)**

Element	Test Method	Concentration				
		1	10	50	100	500
Vanadium	A	...	...	8.9	19	112
	B			7.4	16	93
Nickel	A	...	2.5	8.7	15	...
	B		1.0	8.1	20	
Iron	A	0.68	1.5	...	...	...
	B	0.91	2.9			

## APPENDIXES

### (Nonmandatory Information)

#### X1. QUALITY CONTROL

X1.1 Confirm the performance of the instrument or the test procedure by analyzing a quality control (QC) sample.

X1.2 Prior to monitoring the measurement process, the user of the method needs to determine the average value and control limits of the QC sample (see Practice [D6299](#) and *ASTM MNL 7*).<sup>8</sup>

X1.3 Record the QC results and analyze by control charts or other statistically equivalent techniques to ascertain the statistical control status of the total testing process (see Practice [D6299](#) and *ASTM MNL 7*). Any out-of-control data should trigger investigation for root cause(s). The results of this investigation may, but not necessarily, result in instrument re-calibration.

X1.4 In the absence of explicit requirements given in the test method, the frequency of QC testing is dependent on the

criticality of the quality being measured, the demonstrated stability of the testing process, and customer requirements. Generally, a QC sample is analyzed each testing day with routine samples. The QC frequency should be increased if a large number of samples are routinely analyzed. However, when it is demonstrated that the testing is under statistical control, the QC testing frequency may be reduced. The QC sample precision should be checked against the ASTM method precision to ensure data quality.

X1.5 It is recommended, if possible, the type of QC sample that is regularly tested be representative of the material routinely analyzed. An ample supply of QC sample material should be available for the intended period of use, and must be homogenous and stable under the anticipated storage conditions.

X1.6 See Practice [D6299](#) and *ASTM MNL 7* for further guidance on QC and Control Charting techniques.

<sup>8</sup> ASTM MNL 7, *Manual on Presentation of Data Control Chart Analysis*, 6th ed., ASTM International, W. Conshohocken.

## **X2. HELPFUL HINTS FOR OPERATION OF TEST METHODS D5708**

X2.1 It is extremely important to homogenize the crude or fuel oil in the sample container to obtain a representative specimen. Otherwise it can lead to erroneous results.

X2.2 Work in a well-ventilated hood, and use adequate protection as prescribed in the appropriate safety practices.

X2.3 Check the temperature and humidity controls of the laboratory containing the ICPAES instruments and verify adequacy for performing accurate and precise analyses. Ensure that stable environmental conditions exist throughout the period of use.

X2.4 Check the accuracy of elemental concentrations of commercially obtained calibration standards before use, either by comparing against suitable primary standards, or by an independent analytical method.

X2.5 Verify the absence of analytes in all solvents and reagents used, by performing a wavelength scan. The net intensity should be zero.

X2.6 Establish the preparation frequency of calibration standards by experiment. Prepare fresh working and check standards before each set of measurements or daily as appropriate.

X2.7 Check the linearity of the calibration curve of each analyte every 3 months or more frequently.

X2.8 Inspect torches before use for cracks and discard or repair as appropriate.

X2.9 Use clean torches that are free of carbon build-up.

X2.10 Replace or clean the load coil if oxidation is observed.

X2.11 Allow the instrument to warm-up for at least 30 min or longer as suggested by the manufacturer.

X2.12 Visually inspect the peristaltic pump tubing daily for cracks, and replace if defective. Verify the uptake rates daily.

X2.13 Run the blank and appropriate check standard after every fifth sample or if at least 30 minutes have elapsed from the time of the last analysis. Recalibrate if the net intensity of the standard changes by more than 5 % relative to the previous check.

X2.14 Allow sufficient rinse time (not less than 60 s) between measurements to avoid memory effects. Memory effects are present if a steady instead of an abrupt decrease in signal is observed from taking multiple measurements.

X2.15 Use the peak and background wavelengths suggested in the method, if possible. When there is a choice, such as with

sequential instruments, choose the wavelengths that will yield signals of 100 times to 1000 times the detection limit. Also, ensure that the chosen wavelengths will not be interfered with from unexpected elements.

X2.16 Check for all spectral interferences expected from the elements present in the sample. Follow the manufacturer's operating guide to develop and apply correction factors to compensate for the interferences. Avoid spectral interferences where possible by judicious choice of wavelength or by comparing the results of two different wavelengths for the same element. See the spectral interferences section in the method for guidance.

X2.17 Ensure that elements will not react with one another resulting in insoluble compounds when preparing multi-element standards.

X2.18 Although the use of a high-solids Babington type nebulizer is optional in the test method, it is highly recommended that it be used to avoid plugging problems.

X2.19 Dilute the sample and standards as much as possible to minimize nebulizer transport effects caused by high viscosity oils or viscosity improvers and additives in the oil, and to reduce potential spectral interferences. Both standard and sample solutions should not contain more than 10 mass % oil.

X2.20 Ensure that the standard solutions contain the same mass % oil as sample solutions. Maintain the correct amount of oil by adding analyte-free base oil. Maintain consistent oil to solvent ratio when diluting.

X2.21 Check for carbon build-up on the torch while nebulizing the working standard. Make the necessary adjustments to eliminate build-up. These adjustments may consist of the following:

X2.21.1 Reducing the pump rate.

X2.21.2 Increasing the auxiliary gas flow.

X2.21.3 Using a chilled spray chamber.

X2.21.4 Diluting the sample.

X2.21.5 Making other adjustments described in the instrument manual.

X2.22 Differences in the viscosities of the test specimen solutions and standard solutions can cause differences in the uptake rates adversely affecting the accuracy of the analysis. Use a base oil that is free of analytes and having a viscosity at room temperature as close as possible to that of the sample to be analyzed. These effects can be minimized by using a peristaltic pump. Use of a peristaltic pump is strongly recommended to provide a constant flow of the solution.



**SUMMARY OF CHANGES**

Subcommittee D02.03 has identified the location of selected changes to this standard since the last issue (D5708 – 12<sup>E1</sup>) that may impact the use of this standard. (Approved Dec. 1, 2015.)

(1) Revised 12.3 to require that all glassware used in the test method be thoroughly cleaned and rinsed with water.

*ASTM International takes no position respecting the validity of any patent rights asserted in connection with any item mentioned in this standard. Users of this standard are expressly advised that determination of the validity of any such patent rights, and the risk of infringement of such rights, are entirely their own responsibility.*

*This standard is subject to revision at any time by the responsible technical committee and must be reviewed every five years and if not revised, either reapproved or withdrawn. Your comments are invited either for revision of this standard or for additional standards and should be addressed to ASTM International Headquarters. Your comments will receive careful consideration at a meeting of the responsible technical committee, which you may attend. If you feel that your comments have not received a fair hearing you should make your views known to the ASTM Committee on Standards, at the address shown below.*

*This standard is copyrighted by ASTM International, 100 Barr Harbor Drive, PO Box C700, West Conshohocken, PA 19428-2959, United States. Individual reprints (single or multiple copies) of this standard may be obtained by contacting ASTM at the above address or at 610-832-9585 (phone), 610-832-9555 (fax), or service@astm.org (e-mail); or through the ASTM website (www.astm.org). Permission rights to photocopy the standard may also be secured from the Copyright Clearance Center, 222 Rosewood Drive, Danvers, MA 01923, Tel: (978) 646-2600; <http://www.copyright.com/>*