



Designation: D5707 – 16

Standard Test Method for Measuring Friction and Wear Properties of Lubricating Grease Using a High-Frequency, Linear-Oscillation (SRV) Test Machine¹

This standard is issued under the fixed designation D5707; the number immediately following the designation indicates the year of original adoption or, in the case of revision, the year of last revision. A number in parentheses indicates the year of last reapproval. A superscript epsilon (ϵ) indicates an editorial change since the last revision or reapproval.

1. Scope*

1.1 This test method covers a procedure for determining a lubricating grease's coefficient of friction and its ability to protect against wear when subjected to high-frequency, linear-oscillation motion using an SRV test machine at a test load of 200 N, frequency of 50 Hz, stroke amplitude of 1.00 mm, duration of 2 h, and temperature within the range of the test machine, specifically, ambient to 280 °C. Other test loads (10 N to 1200 N for SRVI-model, 10 N to 1400 N for SRVII-model, and 10 N to 2000 N for SRVIII-model), frequencies (5 Hz to 500 Hz) and stroke amplitudes (0.1 mm up to 4.0 mm) can be used, if specified. The precision of this test method is based on the stated parameters and test temperatures of 50 °C and 80 °C. Average wear scar dimensions on ball and coefficient of friction are determined and reported.

NOTE 1—Optimol Instruments supplies an upgrade kit to allow SRVI/II-machines to operate with 1600 N, if needed.

1.2 This test method can also be used for determining a fluid lubricant's ability to protect against wear and its coefficient of friction under similar test conditions.

1.3 The values stated in SI units are to be regarded as standard. No other units of measurement are included in this standard.

1.4 *This standard does not purport to address all of the safety concerns, if any, associated with its use. It is the responsibility of the user of this standard to establish appropriate safety and health practices and determine the applicability of regulatory limitations prior to use.*

2. Referenced Documents

2.1 ASTM Standards:²

¹ This test method is under the jurisdiction of ASTM Committee D02 on Petroleum Products, Liquid Fuels, and Lubricants and is the direct responsibility of Subcommittee D02.G0.04 on Functional Tests - Tribology.

Current edition approved Oct. 1, 2016. Published January 2017. Originally approved in 1995. Last previous edition approved in 2011 as D5707 – 11. DOI: 10.1520/D5707-16.

² For referenced ASTM standards, visit the ASTM website, www.astm.org, or contact ASTM Customer Service at service@astm.org. For *Annual Book of ASTM Standards* volume information, refer to the standard's Document Summary page on the ASTM website.

[A295/A295M Specification for High-Carbon Anti-Friction Bearing Steel](#)

[D217 Test Methods for Cone Penetration of Lubricating Grease](#)

[D4175 Terminology Relating to Petroleum Products, Liquid Fuels, and Lubricants](#)

[D5706 Test Method for Determining Extreme Pressure Properties of Lubricating Greases Using a High-Frequency, Linear-Oscillation \(SRV\) Test Machine](#)

[D6425 Test Method for Measuring Friction and Wear Properties of Extreme Pressure \(EP\) Lubricating Oils Using SRV Test Machine](#)

[D7755 Practice for Determining the Wear Volume on Standard Test Pieces Used by High-Frequency, Linear-Oscillation \(SRV\) Test Machine](#)

[E45 Test Methods for Determining the Inclusion Content of Steel](#)

[G40 Terminology Relating to Wear and Erosion](#)

2.2 Other Standards:³

[DIN EN ISO 683-17 Heat-treated Steels, alloy steels and free-cutting steels—Part 17 : Ball and roller bearing steels](#)

[DIN 51834-3 Testing of lubricants—Tribological test in translatory oscillation apparatus—Part 3: Determination of tribological behaviour of materials in cooperation with lubricants](#)

[DIN EN ISO 13565-2:1998 Geometrical Product Specifications \(GPS\)—Surface texture: Profile method; Surfaces having stratified functional properties —Part 2: Height characterization using linear material ratio curve \[Replaces DIN 4776:1990: Measurement of surface roughness; parameters \$R_K\$, \$R_{PK}\$, \$R_{VK}\$, \$M_{r1}\$, \$M_{r2}\$ for the description of the material portion\]](#)

3. Terminology

3.1 Definitions:

3.1.1 *break-in, n—in tribology*, an initial transition process occurring in newly established wearing contacts, often accompanied by transients in coefficient of friction or wear rate, or

³ Available from Deutsches Institut für Normung e.V.(DIN), Burggrafenstrasse 6, 10787 Berlin, Germany, <http://www.din.de>.

*A Summary of Changes section appears at the end of this standard

both, which are uncharacteristic of the given tribological system's long-term behavior. **G40**

3.1.2 *coefficient of friction, n*—in tribology, the dimensionless ratio of the friction force (F) between two bodies to the normal force (N) pressing these bodies together. **G40**

3.1.3 *Hertzian contact area, n*—the apparent area of contact between two nonconforming solid bodies pressed against each other, as calculated from Hertz's equations of elastic deformation. **G40**

3.1.4 *Hertzian contact pressure, n*—magnitude of the pressure at any specified location in a Hertzian contact area, as calculated from Hertz's equations of elastic deformation. The Hertzian contact pressure can also be calculated and reported as maximum value P_{\max} in the centre of the contact or as P_{average} as average over the total contact area. **G40**

3.1.5 *lubricant, n*—any material interposed between two surfaces that reduces the friction or wear between them. **D4175**

3.1.6 *lubricating grease, n*—a semifluid to solid product of a dispersion of a thickener in a liquid lubricant.

3.1.6.1 *Discussion*—The dispersion of the thickener forms a two-phase system and immobilizes the liquid lubricant by surface tension and other physical forces. Other ingredients are commonly included to impart special properties. **D217**

3.1.7 *Ra (C.L.A.), n*—measuring surface finish, the arithmetic average of the absolute distances of all profile points from the mean line for a given distance.⁴

3.1.7.1 *Discussion*—C.L.A. means center line average, and it is a synonym for Ra.

3.1.8 *Rpk, n*—reduced peak height according to DIN EN ISO 13565-2:1998. Rpk is the mean height of the peak sticking out above the core profile section.

3.1.9 *Rvk, n*—reduced valley height according to DIN EN ISO 13565-2:1998. Rvk is the mean depth of the valley reaching into the material below the core profile section.

3.1.10 *Rz (DIN), n*—in measuring surface finish, the average of all Ry values (peak to valley heights) in the assessment length.⁵

3.1.11 *thickener, n*—in lubricating grease, a substance composed of finely divided particles dispersed in a liquid lubricant to form the product's structure.

3.1.11.1 *Discussion*—The thickener can be fibers (such as various metallic soaps) or plates or spheres (such as certain non-soap thickeners) which are insoluble or, at most, only very slightly soluble in the liquid lubricant. The general requirements are that the solid particles be extremely small, uniformly dispersed, and capable of forming a relatively stable, gel-like structure with the liquid lubricant. **D217**

3.1.12 *wear, n*—damage to a solid surface, generally involving progressive loss of material, due to the relative motion between that surface and a contacting substance or substances. **G40**

3.1.13 *Wv, n*—Wear volume is the loss of volume to the ball after a test. **D6425**

3.2 *Definitions of Terms Specific to This Standard:*

3.2.1 *seizure, n*—localized fusion of metal between the rubbing surfaces of the test pieces.

3.2.1.1 *Discussion*—Seizure is usually indicated by a sharp increase in coefficient of friction, wear, or unusual noise and vibration. In this test method, increase in coefficient of friction is displayed on the chart recorder as a permanent rise in the coefficient of friction from a steady state value.

3.3 *Abbreviations:*

3.3.1 *SRV, n*—Schwingung, Reibung, Verschleiss, (German); oscillating, friction, wear, (English translation). **D5706**

4. Summary of Test Method

4.1 This test method is performed on an SRV test machine using a test ball oscillated under constant load against a test disk.

NOTE 2—The frequency of oscillation, stroke length, test temperature, test load, and test ball and disk material can be varied from those specified in this test method. The test ball yields Hertzian point contact geometry. To obtain line or area contact, test pieces of differing configurations can be substituted for the test ball.

4.2 The wear scar on the test ball and coefficient of friction are measured. If a profilometer is available, a trace of the wear scar on the test disk can also be used to obtain additional wear information in order to calculate the wear volumes of ball and disk by using Practice **D7755** or DIN 51834, part 3.

5. Significance and Use

5.1 This test method can be used to determine wear properties and coefficient of friction of lubricating greases at selected temperatures and loads specified for use in applications where high-speed vibrational or start-stop motions are present for extended periods of time under initial high Hertzian point contact pressures. This test method has found application in qualifying lubricating greases used in constant velocity joints of front-wheel-drive automobiles and for lubricating greases used in roller bearings. Users of this test method should determine whether results correlate with field performance or other applications.

6. Apparatus

6.1 *SRV Test Machine*,⁶ illustrated in Figs. 1-4.

6.2 *Microscope*, equipped with a filar eyepiece graduated in 0.005 mm division or equipped with a micrometer stage readable to 0.005 mm. Magnification should be sufficient to allow for ease of measurement. One to 10 \times magnification has been found acceptable.

⁶ The sole source of supply of the apparatus known to the committee at this time is Optimol Instruments Prüftechnik GmbH, Westendstrasse 125, D-80339, Munich, Germany, <http://www.optimol-instruments.de>. If you are aware of alternative suppliers, please provide this information to ASTM International Headquarters. Your comments will receive careful consideration at a meeting of the responsible technical committee,¹ which you may attend.

⁴ Amstutz, Hu, "Surface Texture: The Parameters," Bulletin MI-TP-003-0785, Sheffield Measurement Division, Warner and Swasey, 1985, p. 21.

⁵ Amstutz, Hu, "Surface Texture: The Parameters," Bulletin MI-TP-003-0785, Sheffield Measurement Division, Warner and Swasey, 1985, pp. 29, 31.



FIG. 1 SRV Test Machine (Model III)

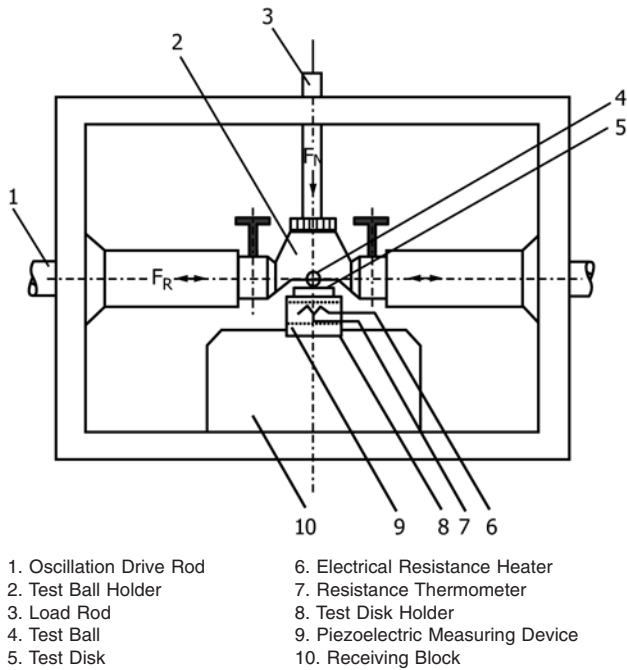

FIG. 2 Test Chamber Elements of SRV III



FIG. 3 SRV Test Machine (Model IV)

7. Reagents and Materials

7.1 *Test Balls*⁶, 52100 steel, Rockwell hardness number of 60 ± 2 on Rockwell C scale (HRC), $0.025 \mu\text{m} \pm 0.005 \mu\text{m}$ R_a surface finish, 10 mm diameter.

7.2 *Lower Test Disk*,⁶ vacuum arc remelted (VAR) AISI 52100 steel with an inclusion rating using Method D, Type A, as severity level number of 0.5 according to Test Methods E45 and Specification A295/A295M or an inclusion sum value $K1 \leq 10$ according to DIN EN ISO 683-17 and spheroidized annealed to obtain globular carbide, Rockwell hardness number of 60 ± 2 on Rockwell C scale (HRC), the surfaces of the disk being lapped and free of lapping raw materials. The topography of the disk will be determined by four values, 24 mm diameter by 7.85 mm thick:

$0.5 \mu\text{m} < R_z \text{ (DIN)} < 0.650 \mu\text{m}$
 $0.035 \mu\text{m} < R_a \text{ (C.L.A.)} < 0.050 \mu\text{m}$
 $0.020 \mu\text{m} < R_{pk} < 0.035 \mu\text{m}$
 $0.050 \mu\text{m} < R_{vk} < 0.075 \mu\text{m}$

NOTE 3—The DIN 17230-1980 was replaced by DIN EN ISO 683-17.

7.3 *n-Heptane*, reagent grade. (**Warning**—Flammable. Health hazard.)

7.4 *Isopropanol*, reagent grade. (**Warning**—Flammable. Health hazard.)

7.5 *Toluene*, reagent grade. (**Warning**—Flammable. Health hazard.)

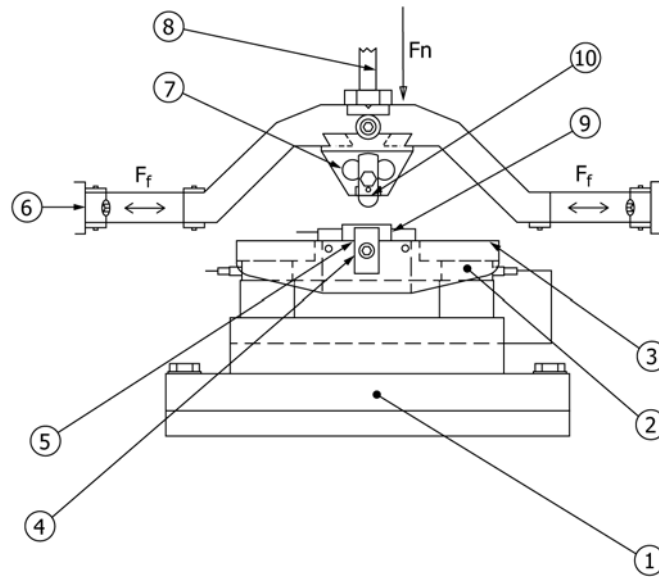

- | | |
|---|--|
| <p>1. Base of the Receiving Block
 2. Piezo Force Measurement Elements
 3. Supporting Surface (Head Plate) of the Receiving Block
 4. Lower Specimen Holder
 5. Position of the Electrical Resistance Heating and Resistance Thermometer
 6. Oscillation Drive Rods</p> | <p>7. Upper Specimen Holder
 8. Drive Rods of the Load Unit
 9. Test Disk
 10. Test Ball
 F_n Normal Force (Test Load)
 F_f Friction Force</p> |
|---|--|

FIG. 4 Test Chamber Elements of SRV Models IV and SRV V

7.6 *Cleaning Solvent*, the test disks have to be cleaned by a liquid solvent (non-chlorinated, non-film forming).

NOTE 4—It is recommended to use a mixture of equal volumes of *n*-heptane, isopropanol, and toluene, all as reagent grades. (**Warning**—Flammable. Health hazard.)

8. Preparation of Apparatus

Preparation of SRV I and II Models

8.1 Turn on the test machine and chart recorder and allow to warm up for 15 min prior to running tests.

8.2 Select the friction data to be presented in the crest peak value position on the test apparatus in accordance with the manufacturer's directions.

NOTE 5—In most cases, this is accomplished by positioning the sliding switch on electronic card No. 291.35.20E (front side of electronics behind the front panel) and the sliding switch located on the back panel of the control unit.

8.3 Turn the amplitude knob to ZERO.

8.4 Switch the stroke adjustment to AUTO position.

8.5 Set the frequency to 50 Hz and duration to 2 h, 00 min, 30 s, in accordance with the manufacturer's instructions.

8.6 Set the desired span and calibrate the chart recorder in accordance with the manufacturer's instructions. Select the desired chart speed.

Preparation of the SRV III, IV, and V Models

8.7 When using SRV III, SRV IV, and SRV V models, clean and install the specimens as specified under 9.1 to 9.7. Turn on

the test machine and the PC and allow to warm up for 15 min prior to running tests.

8.8 Create a set point profile in the SRV control software with the following parameters:

NOTE 6—Depending on the software version, names and availability of the parameters can vary.

8.8.1 Start conditions (thermostatic stabilization):

Temperature: for example, 50 °C ± 1 K or 80 °C ± 1 K or 120 °C ± 1 K
 Test load: 50 N ± 1 N
 Start delay: 300 s (is displayed by all versions of the SRV software).

8.8.2 Cut-off criteria for friction, if occurs:

Coefficient of friction, *f* (cut-off value for permanent increase of level):
 0.3 during $t > 20$ s
 Coefficient of friction, *f* (cut-off value for one-off increase of level): 0.35

8.8.3 Test parameters:

Frequency: 50 Hz
 Stroke: 1.00 mm for procedure
 Temperature: for example, 50 °C, 80 °C, or 120 °C
 Pre-load: 50 N for 30 s
 Test load: running-in under 50 N for 30 s, then steps of 200 N

8.8.4 Sample rates for result-relevant measurement channels:

Coefficient of friction, *f*: ≤32 ms.
 Stroke: ≤2 s
 Test load: ≤2 s
 Frequency: ≤2 s
 Temperature: ≤2 s
 After that, apply a load increment of 100 N every 2 min

NOTE 7—For SRV V models, it is recommended to do one sampling per period (that is, 20 ms) for coefficient of friction and stroke.

9. Procedure

9.1 *Procedure for All SRV Models*—SRV III, IV, and V models are fully computer-controlled and allow automated tests.

9.1.1 Using solvent resistant gloves, clean the test ball and disk by wiping the surfaces with laboratory tissue soaked with the cleaning solvent. Repeat wiping until no dark residue appears on the tissue. Immerse the test ball and disk in a beaker of the cleaning solvent under ultrasonic vibration for 10 min. Dry the test ball and disk with a clean tissue to ensure no streaking occurs on the surface.

9.1.2 Ensure that the test load unit is in the release position (refer to operating manual for details).

9.1.3 Place a small amount (approximately 0.1 g to 0.2 g, the size of a pea) of lubricating grease to be tested on the cleaned lower test disk in an area such that overlapping with previous wear scars will not occur. Alternatively, place the grease caliper with 1.5 mm in height on the cleaned disc. Fill the opening of the grease caliper with grease. Remove any excess grease by means of a spatula. Remove the grease caliper by lifting it upwards.

9.1.4 Place the cleaned test ball on the top and in the middle of the lubricating grease specimen so that the grease makes a circular symmetric pad between the ball and disk.

9.2 *Procedure for SRV III, IV, and V Models:*

9.2.1 Open the Assistant for starting a test in the SRV control software. Select the created set-point profile and, if necessary (for example, SRV V), the data logger configuration and proceed through the Assistant until the pre-load has been applied.

9.2.2 Then set the test load unit to 50 N and release and retighten the ball and disk clamps to a torque of 2.5 Nm.

9.2.3 The heater control starts automatically and heats up to the pre-set and desired temperature. 50 °C, 80 °C, or 120 °C.

9.2.4 Follow the directions in the Assistant for starting a test in the SRV control software until the automated test run mode (waiting for reaching start conditions) is started. The test starts automatically when the pre-set delay (for example, 300 s) has expired. The test can also be started manually. The test machine will automatically stop.

9.3 *Procedure for SRV I and II Models:*

9.3.1 Ensure the machine is unloaded (indicated by a load reading of -13 N or -14 N) and carefully place the disk containing the lubricating grease specimen and test ball on the test area platform.

9.3.2 Tighten both the ball and disk clamps until resistance to tightening just begins. Load unit to 100 N and tighten the ball and disk clamps to a torque of 2.5 N·m. Reduce the load to 50 N for break-in.

9.3.3 Turn on the heater control and set to the desired temperature.

9.3.4 When temperature has stabilized, turn on the chart recorder paper feed, and lower the recording pens. Depress the drive start toggle switch until the timer begins to count and then adjust the stroke amplitude knob to 1.00 mm.

NOTE 8—Stroke should be checked periodically by measuring the wear track length minus the ball scar diameter. The difference must be smaller

than $\pm 10\%$ of the set stroke.

9.3.5 When the digital timer reaches 30 s, increase the load to 200 N on the slow ramp speed setting and run at that load for 2 h \pm 15 s. The test machine will automatically stop.

9.3.6 At the end of the test, turn off the heater control, turn power back on, and reduce the load to -13 N or -14 N for disassembly.

NOTE 9—Power automatically turns off at the end of the test.

9.4 *Evaluation Procedure:*

9.4.1 Remove and clean the test ball and disk in accordance with 9.1.

9.4.2 Place the test ball on a suitable holder and by means of a microscope, measure to the nearest 0.005 mm the minimum scar width and again at 90° to the first measurement. Measure the minimum coefficient of friction values from the chart recorder graph. Although not specifically part of the procedure, when additional wear analysis or the wear volume is required, perform a profilometric trace across the wear scar on the test disk in accordance with the profilometer manufacturer's instructions.

NOTE 10—Criteria for using the wear volume are stated in Test Method D6425 and for calculating the wear volume in Practice D7755 or DIN 51834, Part 3.

10. Report

10.1 Report the following information:

10.1.1 All parameters used to evaluate material as follows:

10.1.1.1 Test temperature, °C,

10.1.1.2 Test break-in load, N,

10.1.1.3 Test load, N,

10.1.1.4 Test frequency, Hz,

10.1.1.5 Test stroke, mm,

10.1.1.6 Test ball material,

10.1.1.7 Test disk material, and

10.1.1.8 Test sample.

10.2 Report both wear scar measurements taken on the ball.

10.3 Report the minimum coefficient of friction and, when required by specification, include a copy of the friction recording.

10.4 Report the depth of the wear scar on the lower specimen disk if profilometer reading was made.

11. Precision and Bias

11.1 Eighteen cooperators tested eight greases in the SRV apparatus. Average minimum coefficients of friction ranged from 0.056 to 0.122 and average ball wear scar diameter ranged from 0.50 mm to 0.90 mm.^{7,8} These precision statements were originally published in D5707-95.

11.2 Using this ASTM test method, the DIN working group has conducted 2000 and 2001 international round robin tests at

⁷ Supporting data have been filed at ASTM International Headquarters and may be obtained by requesting Research Report RR:D02-1410. Contact ASTM Customer Service at service@astm.org.

⁸ Dickey, J., "New ASTM and DIN Methods for Measuring Tribological Properties using SRV Test Instrument," *NLGI Spokesman*, March 1997, pp. 17-23.

80 °C with two greases. The results are given, for information purposes, in **Table 1**.⁹

11.3 The statistical analysis of the round robin test results 2010 showed better precision¹⁰ than prescribed in the precision designations. The 37 cooperators tested six greases at 50 °C and 80 °C.

11.4 The precision of this test method, as determined by statistical examination of interlaboratory test results obtained at 200 N load, 50 Hz frequency, and 1 mm stroke at 50 °C and 80 °C is:

11.4.1 *Average Ball Wear Scar Diameter:*

11.4.1.1 *Repeatability*—The difference between successive results obtained by the same operator with the same apparatus under constant operating conditions on identical test material would, in the long run, in the normal and correct operation of the test method, exceed the following value only in one case in twenty.

0.07 mm

11.4.1.2 *Reproducibility*—The difference between two single and independent results obtained by different operators working in different laboratories on identical test method

⁹ Supporting data have been filed at ASTM International Headquarters and may be obtained by requesting Research Report RR:D02-1565. Contact ASTM Customer Service at service@astm.org.

¹⁰ Supporting data have been filed at ASTM International Headquarters and may be obtained by requesting Research Report RR:D02-1845. Contact ASTM Customer Service at service@astm.org.

would, in the long run, exceed the following values only in one case in twenty.

For tests run at 50 °C, 0.29 mm

For tests run at 80 °C, 0.24 mm

11.4.2 *Minimum Coefficient of Friction:*

11.4.2.1 *Repeatability*—The difference between successive results obtained by the same operator with the same apparatus under constant operating condition on identical test material would, in the long run, in the normal and correct operation of the test method exceed the following values only in one case in twenty.

For tests run at 50 °C, 0.012

For tests run at 80 °C, 0.008

11.4.2.2 *Reproducibility*—The difference between two single and independent results obtained by different operators working in different laboratories on identical test materials would, in the long run, exceed the following values only in one case in twenty.

For tests run at 50 °C, 0.031

For tests run at 80 °C, 0.032

11.5 *Bias*—The evaluation of friction and wear properties of lubricating grease by this test method has no bias because coefficients of friction and wear scar diameter can be defined only in terms of the test method.

12. Keywords

12.1 coefficient of friction; lubricating grease; oscillation; SRV; wear

TABLE 1 Statistical Quantities of Different Greases in the International RR2000 and RR2001^A

Year	RR2001		RR2001		RR2000		RR2000	
	Li/Ca12OH stearate grease	PAO/Polybuten/Bentonite	EP Calcium-Sulfonate-complex	ASTM G-2000-02 Lithium complex with MoS ₂ , Zn/S/P	Wear scar diameter of the ball, $W_{K-average}$, mm	Coefficient of friction, f_{END}	Wear scar diameter of the ball, $W_{K-average}$, mm	Coefficient of friction, f_{END}
Degree of freedom	33	33	39	43	37	43	39	43
Mean	0.1175	0.1162	0.1222	0.1116	0.44436	0.11116	0.49891	0.11116
Standard deviation	± 0.0152	± 0.0138	± 0.0108	± 0.0142	± 0.0476	± 0.0142	± 0.0344	± 0.0344
Reproducibility, R	0.02	0.0398	0.0308	0.1116	0.136	0.0406	0.0984	0.0984
Repeatability, r	(set point: ≤ 0.032) 0.0107	(set point: ≤ 0.032) 0.00854	(set point: ≤ 0.032) 0.00903	(set point: ≤ 0.032) 0.0161	(set point: ≤ 0.24) 0.0446	(set point: ≤ 0.032) 0.0161	(set point: ≤ 0.24) 0.00424	(set point: ≤ 0.24) 0.00424

^A RR2000 with 32 to 36 participants and RR2001 with 31 to 33 participants. The repeatability and the reproducibility were calculated using [ADJ6300](#) (D2PP software). (Test conditions: $F_N = 200$ N; $T = 80$ °C; $t = 120$ min; $\Delta x = 1$ mm; $v = 50$ Hz; lapped AISI52100-disks; polished AISI52100-balls, $\varnothing = 10$ mm).

SUMMARY OF CHANGES

Subcommittee D02.G0 has identified the location of selected changes to this standard since the last issue (D5707 – 11) that may impact the use of this standard. (Approved Oct. 1, 2016.)

- (1) Updated procedure to include software-controlled SRV IV and V models. (3) Deleted former Appendix X1.
- (2) Added new Research Report footnote; precision statements are unchanged.

ASTM International takes no position respecting the validity of any patent rights asserted in connection with any item mentioned in this standard. Users of this standard are expressly advised that determination of the validity of any such patent rights, and the risk of infringement of such rights, are entirely their own responsibility.

This standard is subject to revision at any time by the responsible technical committee and must be reviewed every five years and if not revised, either reapproved or withdrawn. Your comments are invited either for revision of this standard or for additional standards and should be addressed to ASTM International Headquarters. Your comments will receive careful consideration at a meeting of the responsible technical committee, which you may attend. If you feel that your comments have not received a fair hearing you should make your views known to the ASTM Committee on Standards, at the address shown below.

This standard is copyrighted by ASTM International, 100 Barr Harbor Drive, PO Box C700, West Conshohocken, PA 19428-2959, United States. Individual reprints (single or multiple copies) of this standard may be obtained by contacting ASTM at the above address or at 610-832-9585 (phone), 610-832-9555 (fax), or service@astm.org (e-mail); or through the ASTM website (www.astm.org). Permission rights to photocopy the standard may also be secured from the Copyright Clearance Center, 222 Rosewood Drive, Danvers, MA 01923, Tel: (978) 646-2600; <http://www.copyright.com/>