



# Standard Test Method for Fluid Tightness Ability of Adhesives Used on Threaded Fasteners<sup>1</sup>

This standard is issued under the fixed designation D5657; the number immediately following the designation indicates the year of original adoption or, in the case of revision, the year of last revision. A number in parentheses indicates the year of last reapproval. A superscript epsilon ( $\epsilon$ ) indicates an editorial change since the last revision or reapproval.

## 1. Scope

1.1 This test method covers the determination of the ability of adhesives used for locking and sealing threaded fasteners, to make leak-tight assemblies.

1.2 The values stated in inch-pound units are to be regarded as the standard. The SI units given in parentheses are for information only.

1.3 *This standard does not purport to address all of the safety concerns, if any, associated with its use. It is the responsibility of the user of this standard to establish appropriate safety and health practices and determine the applicability of regulatory limitations prior to use.*

## 2. Referenced Documents

2.1 *ASTM Standards:*<sup>2</sup>

**D907 Terminology of Adhesives**

2.2 *SAE Standard:*

**SAE J429 Mechanical and Material Requirements for Externally Threaded Fasteners**<sup>3</sup>

2.3 *Federal Specification:*

**FF-N-836 Nut: Square, Hexagon, Cap, Slotted, Castle, Knurled, Welding and Single Ball Seat**<sup>4</sup>

## 3. Terminology

3.1 *Definitions:*

3.1.1 Many of the terms in this test method are defined in Terminology **D907**.

<sup>1</sup> This test method is under the jurisdiction of ASTM Committee **D14** on Adhesives and is the direct responsibility of Subcommittee **D14.80** on Metal Bonding Adhesives.

Current edition approved March 1, 2014. Published March 2014. Originally approved in 1995. Last previous edition approved in 2007 as D5657 – 07. DOI: 10.1520/D5657-07R14.

<sup>2</sup> For referenced ASTM standards, visit the ASTM website, [www.astm.org](http://www.astm.org), or contact ASTM Customer Service at [service@astm.org](mailto:service@astm.org). For *Annual Book of ASTM Standards* volume information, refer to the standard's Document Summary page on the ASTM website.

<sup>3</sup> Available from Society of Automotive Engineers (SAE), 400 Commonwealth Dr., Warrendale, PA 15096-0001, <http://www.sae.org>.

<sup>4</sup> Available from U.S. Government Printing Office Superintendent of Documents, 732 N. Capitol St., NW, Mail Stop: SDE, Washington, DC 20401, <http://www.access.gpo.gov>.

## 4. Summary of Test Method

4.1 This test method consists of subjecting an adhesive-cured nut-and-bolt assembly to 50-psi pressure and determining the cured adhesive's ability to make the assembly leak-tight.

## 5. Significance and Use

5.1 Thread-locking adhesives are often used on threaded fasteners in sealing applications. This test method is used to determine an adhesive's ability to provide sealing capabilities under specified conditions.

## 6. Apparatus

6.1 *Test Fixture*, as shown in **Fig. 1**, consisting of the following:

6.1.1 *Pressure Vessel*, provided with a means of filling with soapy water, capable of applying, withstanding, and measuring 50-psi (345-kPa) pressure of soapy water, and equipped with an air inlet and a gage for supplying and reading the pressure.

6.1.2 *Metal Plate*, flat, smooth approximately 1/2 in. (12.7 mm) thick, drilled with a 3/8-in. (9.5-mm) hole at its center. The hole is counterbored 5/8-in. (15.9-mm) diameter by 1/16 in. (1.6 mm) deep. The metal plate is welded to the pressure vessel.

6.1.3 *Rubber O-Ring or Flat Rubber Gasket*, 5/8-in. (15.9-mm) outside diameter by 7/16-in. (11.1-mm) inside diameter by 3/32 in. (2.4 mm) thick.

6.1.4 *Metal Plate*, used as a means of pressing the nut of the adhesive-treated test specimen against the O-ring or gasket with sufficient force to prevent leakage between the top plate and the washer face of the test specimen nut.

6.1.5 *Studs and Nuts*, used to clamp the fixture.

## 7. Test Specimens

7.1 *Steel Bolts*—3/8-in. size, Grade 5, in accordance with SAE J429, having a minimum length of 1 in. (25.4 mm) with a hexagonal head. Use thread series Unified National Fine, 24 threads per inch (3/8 by 24 UNF), or Unified National Coarse, 16 threads per inch (3/8 by 16 UNC) as agreed upon between the user and the manufacturer of the adhesive.

7.2 *Steel Nuts*—Type II, Style 4, nominally 2 1/64 in. (8.3 mm) thick, conforming to Federal Specification FF-N-836.

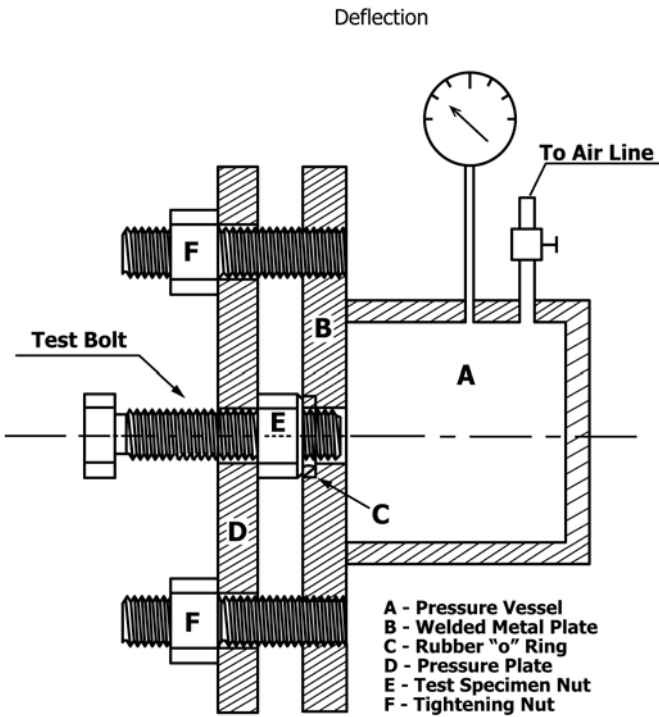

FIG. 1 Fluid-Tightness Test Jig

## 8. Procedure

8.1 Degrease all nut-and-bolt test specimens, keep them clean, and store at 70 to 77°F (21 to 25°C) at a relative humidity of less than 20 %.

8.2 Determine fluid tightness on not less than five specimens as follows:

8.2.1 Apply test adhesive to the threads of the test bolt and nut E. Place the test bolt through the center hole in plate D and screw the test nut onto the bolt by hand, allowing three threads to protrude.

8.2.2 Cure the adhesive in accordance with the manufacturer's instructions, with the test specimens standing vertically on the bolt heads.

8.2.3 Cure the resulting assemblies for 24 to 26 h at 70 to 77°F (21 to 25°C) and 45 to 55 % relative humidity.

8.2.4 After curing, position the fixture with the top plate up and fill the pressure vessel with room-temperature water to which sufficient soap or synthetic wetting agent has been added to reduce its surface tension.

8.2.5 Set the O-ring or gasket and the test specimen in place and swivel the bottom plate over the specimen and the tightening studs.

8.2.6 Clamp the test specimen in position by tightening the nuts of the studs against the bottom plate, forcing the nut of the test specimen against the O-ring or gasket.

8.2.7 Reposition the apparatus so that the fluid level is above the test specimen.

8.2.8 Apply 50 ± 5-psi pressure to the water and determine if leakage occurs between the threads of the test nut and bolt within 1 min of applying the pressure.

## 9. Report

9.1 Report the following information:

9.1.1 Complete identification of the adhesive tested, including type, source, date manufactured, manufacturer's code numbers, and form,

9.1.2 Number of specimens tested, and

9.1.3 Number of specimens that leaked.

## 10. Precision and Bias

10.1 Precision and bias for this test method are being determined and will be available by April 2005.

## 11. Keywords

11.1 adhesive; fluid tightness; sealing; threadlocking

*ASTM International takes no position respecting the validity of any patent rights asserted in connection with any item mentioned in this standard. Users of this standard are expressly advised that determination of the validity of any such patent rights, and the risk of infringement of such rights, are entirely their own responsibility.*

*This standard is subject to revision at any time by the responsible technical committee and must be reviewed every five years and if not revised, either reapproved or withdrawn. Your comments are invited either for revision of this standard or for additional standards and should be addressed to ASTM International Headquarters. Your comments will receive careful consideration at a meeting of the responsible technical committee, which you may attend. If you feel that your comments have not received a fair hearing you should make your views known to the ASTM Committee on Standards, at the address shown below.*

*This standard is copyrighted by ASTM International, 100 Barr Harbor Drive, PO Box C700, West Conshohocken, PA 19428-2959, United States. Individual reprints (single or multiple copies) of this standard may be obtained by contacting ASTM at the above address or at 610-832-9585 (phone), 610-832-9555 (fax), or service@astm.org (e-mail); or through the ASTM website (www.astm.org). Permission rights to photocopy the standard may also be secured from the Copyright Clearance Center, 222 Rosewood Drive, Danvers, MA 01923, Tel: (978) 646-2600; http://www.copyright.com/*