



# Standard Test Methods for Single-Bolt Connections in Wood and Wood-Based Products<sup>1</sup>

This standard is issued under the fixed designation D5652; the number immediately following the designation indicates the year of original adoption or, in the case of revision, the year of last revision. A number in parentheses indicates the year of last reapproval. A superscript epsilon ( $\epsilon$ ) indicates an editorial change since the last revision or reapproval.

## 1. Scope

1.1 These test methods cover procedures for evaluating the strength and stiffness of single-bolt connections in wood or wood-based products when subjected to short-term static loading. These test methods serve as a basis for determining the effects of various factors on the strength and stiffness of the connection. Long-term loading and creep displacement characteristics are outside the scope of this protocol.

1.2 These test methods are intended for situations employing a smooth shank bolt with a constant diameter.

1.3 The values stated in inch-pound units are to be regarded as the standard. The SI units in parentheses are for information only.

1.4 *This standard does not purport to address all of the safety concerns, if any, associated with its use. It is the responsibility of the user of this standard to establish appropriate safety and health practices and determine the applicability of regulatory limitations prior to use.*

## 2. Referenced Documents

2.1 *ASTM Standards:*<sup>2</sup>

[D2395 Test Methods for Density and Specific Gravity \(Relative Density\) of Wood and Wood-Based Materials](#)

[D2915 Practice for Sampling and Data-Analysis for Structural Wood and Wood-Based Products](#)

[D4442 Test Methods for Direct Moisture Content Measurement of Wood and Wood-Based Materials](#)

[E4 Practices for Force Verification of Testing Machines](#)

[E2309/E2309M Practices for Verification of Displacement Measuring Systems and Devices Used in Material Testing Machines](#)

<sup>1</sup> These test methods are under the jurisdiction of ASTM Committee D07 on Wood and are the direct responsibility of Subcommittee D07.05 on Wood Assemblies.

Current edition approved Dec. 1, 2015. Published February 2016. Originally approved in 1995. Last previous edition approved in 2013 as D5652 – 95 (2013). DOI: 10.1520/D5652-15.

<sup>2</sup> For referenced ASTM standards, visit the ASTM website, [www.astm.org](http://www.astm.org), or contact ASTM Customer Service at [service@astm.org](mailto:service@astm.org). For *Annual Book of ASTM Standards* volume information, refer to the standard's Document Summary page on the ASTM website.

[F606/F606M Test Methods for Determining the Mechanical Properties of Externally and Internally Threaded Fasteners, Washers, Direct Tension Indicators, and Rivets](#)

2.2 *Federal Specification:*

[Fed. Spec. FF-W-92 for Washers, Metal, Flat \(Plain\)](#)

2.3 *Other Standards:*

[NDS ANSI/AWC National Design Specification for Wood Construction](#)

## 3. Summary of Test Methods

3.1 Specimens consisting of at least one wood or wood-based member fastened with one bolt to at least one other member of any material are evaluated for capacity to resist compressive or tensile forces applied at a constant speed of displacement with a suitable testing machine. The slip, or displacement, of the connection at various intervals of loading is measured. Supplementary physical properties of the wood or wood-based members are also determined.

## 4. Significance and Use

4.1 Connections are one of the most important components in wood construction. While the strength of metal bolts and of wood or wood-based products are ascertainable, a full evaluation of the performance of the combination is only possible through the testing of a complete connection assembly. Such variables as member thickness, member width, end and edge distances, type of bolt, fabrication tolerances, moisture content of the wood or wood-based product, preservative or fire-retardant treatment of the wood or wood-based product, species of wood, and/or material type and orientation of wood-based material may affect connection behavior. In order to develop design criteria for established bolt types as well as those under development, the effect of these variables on connection strength and stiffness must be known. The tests described herein permit the observation of data on the strength and stiffness of wood or wood-based connections, or both, under the influence of any or all of these factors.

## 5. Apparatus

5.1 *Testing Machine*—Any suitable testing machine capable of operation at a constant movable crosshead speed and having an accuracy of  $\pm 1\%$  when calibrated in accordance with Practices E4.

5.2 *Spherical Bearing Block*, for compressive loading of specimens.

5.3 *Grips*—Gripping devices capable of attaching the specimen to the stationary and moving heads of the testing machine in such a way as to ensure true axial tensile loads.

5.4 *Displacement Measurement Devices*—At least two displacement measurement devices for measuring the slip between connection members during load application. These devices shall be capable of at least a Class B rating when evaluated in accordance with Practice E2309/E2309M.

## 6. Sampling

6.1 Sampling shall provide for selection of representative test specimens that are appropriate to the objectives of the testing program.

6.2 Sample size shall be estimated in accordance with the procedures of Method D2915; however, a minimum of ten tests shall be conducted to evaluate each connection configuration or variable. See Note 1 for guidance in this respect.

NOTE 1—The precision required, and thus, the manner of sampling and the number of tests, depend upon the specific test objectives. No specific criteria can therefore be established. General experience indicates that the coefficients of variation from tests on connections range from approximately 15 to 30%. Depending upon the objectives of the test, it is important to understand the different failure modes that might occur between specimens for a given test configuration, the variation associated with those modes, and their impact upon variability. For those configurations that result in multiple modes of failure, it may be necessary to conduct exploratory testing to establish the expected variability.

## 7. Test Specimens

### 7.1 Material Selection:

7.1.1 *Wood*—Select wood members, and position the bolt in them in such a way that the results are not affected by knots, cross grain, or other natural or manufacturing characteristics unless the purpose of the test methods is to evaluate the effects of such growth characteristics. When the effects of growth characteristics are not being evaluated, wood members shall be essentially clear and straight-grained. Unless otherwise specified to satisfy the test objectives, the wood members shall be selected to target an average oven-dry specific gravity representative of the material to be evaluated.

7.1.2 *Wood-Based Material*—For wood-based products, such as structural composite lumber or wood plastic composites, the specimen grade, density, thickness and other manufactured characteristics shall be representative of the material to be evaluated. Since the connection properties of a wood-based product typically vary with the cross-sectional product orientation, the bolt shall be positioned in the cross-sectional orientation to be evaluated and that orientation shall be recorded. Unless the purpose of the study is to evaluate a product's known strength reducing characteristics, bolts shall be randomly positioned into the member without further bias to consider strength reducing characteristics.

7.1.3 *Non-Uniform Cross-Sections*—Cross-sections selected for testing shall be representative of the product to be evaluated. Some wood-based products are made with a hollow extrusion, significant density gradient profile, or other non-uniformity that has the potential to impact the test results. If the

wood-based product to be tested has a non-uniform cross-section, then the related product characteristics and the bolt position shall be reported in detail.

7.1.4 *Steel*—Steel members used as part of the test program shall have their nominal thickness and grade chosen to satisfy the experimental objectives and be recorded.

7.1.5 *Bolts*—The nominal bolt diameter and grade shall be chosen to satisfy the experimental objectives and be recorded.

NOTE 2—For product evaluation purposes, it may be desirable to select materials that conservatively represent the range of permitted applications. For example, using the lowest permitted specific gravity of wood, the lowest grade of wood-based material, the worst-case non-uniform cross-section, etc. These constraints should be considered on a case-by-case basis.

### 7.2 Connection Assembly:

7.2.1 Connection assemblies shall consist of three members as shown in Figs. 1-3 except where specific data on two- or multiple-member connections are being sought. Select the width, length, and thickness of the members with consideration of required edge and end distances. Member dimensions shall be representative of the test objectives or as required to target specific yield or failure modes.

7.2.2 For members loaded parallel to grain, the minimum end distance shall be seven bolt diameters for tension loading (Fig. 1) and four bolt diameters for compression loading (Fig. 2), unless the effect of various end distances is to be studied. For members loaded perpendicular to grain (Fig. 3), the minimum unloaded edge distance shall be 1.5 bolt diameters and the minimum loaded edge distance shall be four diameters, unless the effect of various edge distances is to be studied.

7.2.3 Unless other bolt-hole diameters are required to satisfy the purposes of the investigation, the bolt-hole diameter shall be  $\frac{1}{16}$  in. (1.6 mm) larger than the nominal bolt diameter for main and side members. Alternative bolt-hole diameters, if used, shall be recorded.

7.2.3.1 Bolt-holes shall be precisely bored perpendicular to the surface, so that the surface of the hole is smooth and uniform to ensure good bearing of the bolt. Holes shall be drilled after members are conditioned unless the purpose of the test is to study the effect of shrinkage on the performance of bolted connections.

7.2.4 Bolts shall be of sufficient length to penetrate all members. The standard configuration shall be to test without having any member bear on the bolt threads. Inclusion of threads within the bearing surfaces shall be permitted provided that thread type and length of threaded bearing are reported.

7.2.5 Place heavy round washers conforming to Fed. Spec. FF-W-92 for washers, metal, flat (plain), and hereafter referred to as a standard washer, between wood or wood-based side members and bolt head and nut. Bring abutting faces of connection members into normally installed contact; then back off the nut and retighten to “finger tightness”.

7.2.6 Primary tests shall be made on connections loaded parallel to and perpendicular to the grain of wood members. Perpendicular to the grain tests shall be conducted as follows:

7.2.6.1 With the grain or strength-axis of the main member perpendicular and the side members perpendicular to the direction of the load,

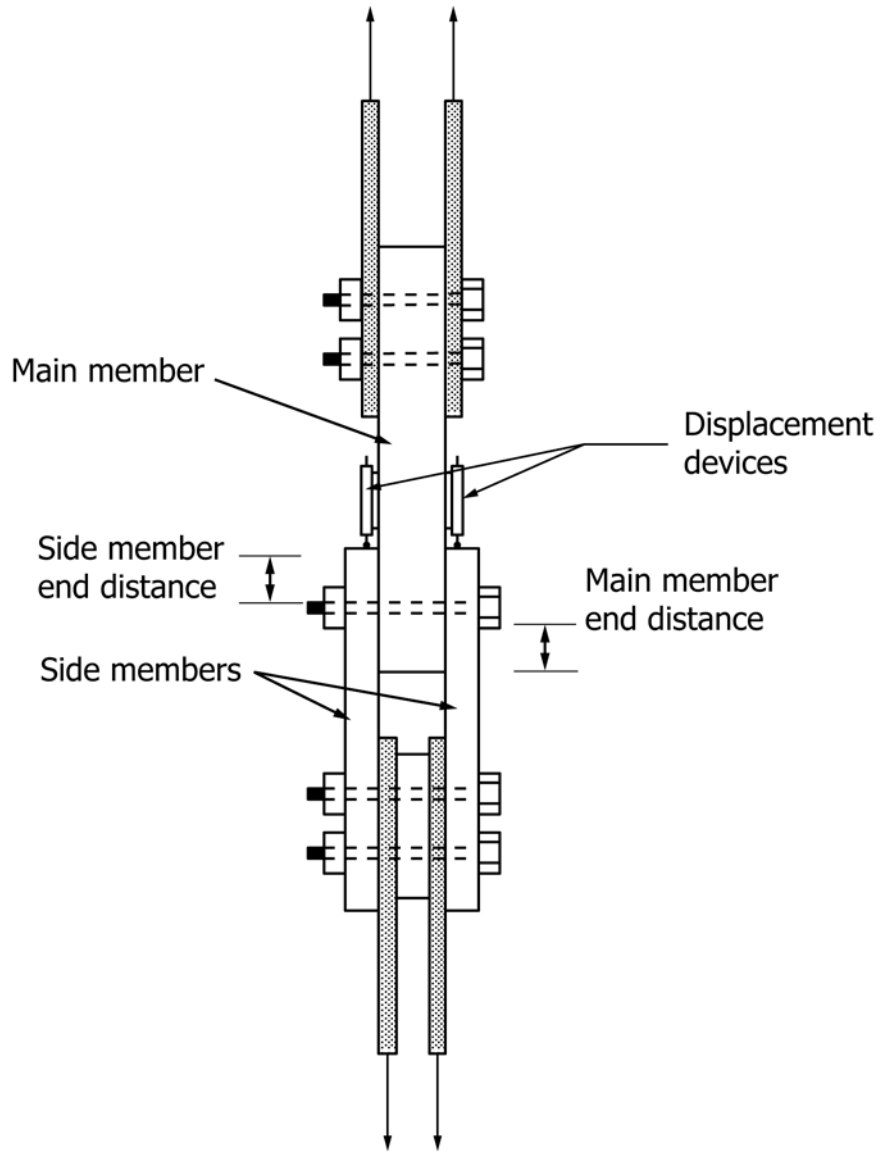

FIG. 1 Assembly for Testing Single-Bolt Connections Parallel to Grain in Tension

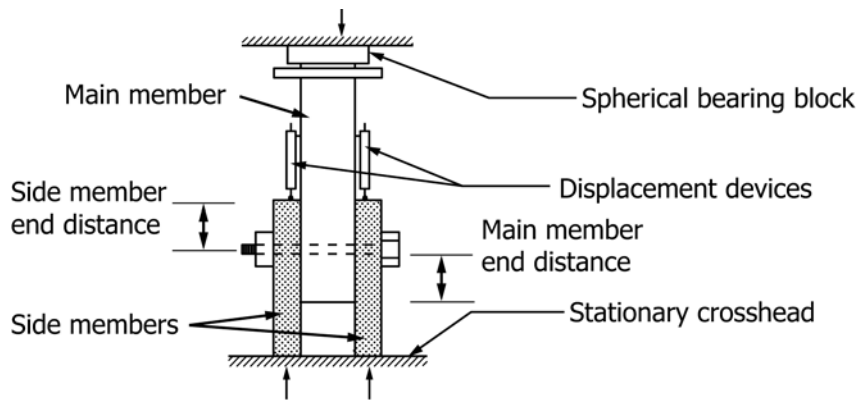

FIG. 2 Assembly for Testing Single-Bolt Connections Parallel to Grain in Compression

7.2.6.2 With the grain or strength-axis of the main member parallel and the side members perpendicular to the direction of the load, or

7.2.6.3 With the grain or strength-axis of the main member perpendicular and the side members parallel to the direction of the load.

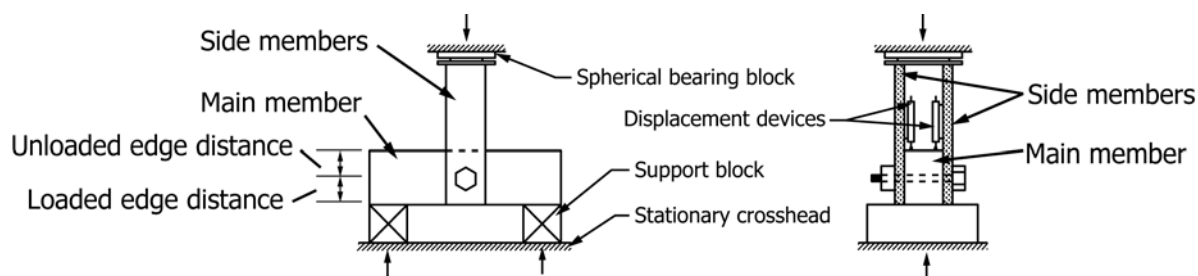

FIG. 3 Assembly for Testing Single-Bolt Connections Perpendicular to Grain in Compression

7.2.7 Primary tests shall be made by applying compressive or tensile loads as required; however, application of tensile load is preferred.

7.2.8 When required by the investigation, conduct additional tests to provide information on the items stated in 7.2.8.1 and 7.2.8.10. In such tests, use a method of matching the material in corresponding members to prevent masking of differences in specific gravity, rate of growth, or other factors:

7.2.8.1 To establish the effect of bearing area and length to diameter ( $L/d$ ) relationship,

7.2.8.2 To determine the effect of variations in main member thickness,

7.2.8.3 To determine the effect of variations in side member thickness,

7.2.8.4 To determine the effect of angle of load to grain of the wood or strength axis of a wood-based material,

7.2.8.5 To establish minimum end distances required for each size of bolt and the effect of variations in end distances,

7.2.8.6 To establish minimum edge distance and the effect of variations in edge distance,

7.2.8.7 To determine the effect of moisture content of the wood or wood-based product,

7.2.8.8 To evaluate wood-based material cross-sectional orientations,

7.2.8.9 To evaluate material non-uniformities, and/or

7.2.8.10 To evaluate any other factor that may affect the performance of the connection.

NOTE 3—The properties of the metal of the bolts and any metal main or side members are also factors affecting the connection strength and behavior. All available data on their properties shall be included in the report. Test Methods F606/F606M provides a means of obtaining mechanical properties of bolts.

## 8. Conditioning

8.1 Conduct the tests with material conditioned to the appropriate conditions for the objectives of the testing program. Maintain the condition of the material prior to and during testing, unless specified otherwise for the purpose of investigation.

## 9. Procedure

9.1 *General*—Test the connections within 1 h after assembly unless the performance of delayed tests is required for the purposes of investigation.

### 9.2 Test Setup:

9.2.1 Connections tested in tension are more representative of behavior in service than those tested in compression; therefore, application of tensile load is preferred. The method of testing a connection in tension parallel to the grain or strength-axis is shown in Fig. 1. Design of the ends of the members where tensile loads are applied is required to ensure failure away from the gripping devices. Use an alignment support when the applied load is eccentric in a two-member specimen.

9.2.2 The method of testing a connection in compression parallel to the grain or strength-axis is shown in Fig. 2. Use a spherical bearing block in applying the load.

9.2.3 The method of conducting a connection test in compression perpendicular to the grain or strength axis is shown in Fig. 3. Maintain a clear distance between the supports of at least three times the depth of the transverse member.

9.3 *Loading*—The procedures described herein are for static loading. When required, evaluate the connection under impact or cyclic loading and fully describe the loading procedure.

9.4 *Slip Measurement*—Use two displacement measurement devices positioned equidistant from the opposing connection surfaces as illustrated in Figs. 1-3 to measure the slip between members of the connection from the initiation of load application. Attach these devices in such a way that the amount of member deformation not associated with connection slip is minimized. The measurements from these devices shall be averaged to represent the slip of the connection. Take readings of the slip at sufficiently frequent load intervals to permit establishment of a satisfactory average load-displacement curve. Observe the general behavior of the connection under load and record observations including the maximum load, the first abrupt decrease in load, the yield mode, the failure mode, and other significant details. Continue the test until the ultimate load is reached. With compressive loading, the test may be stopped at an average displacement of 0.60 in. (15 mm).

NOTE 4—Whenever practical, it is preferable to characterize yield modes as one of the six connection yield modes depicted in Fig. 11 of the American Wood Council's National Design Specification for Wood Construction.

9.5 *Speed of Testing*—Conduct the tests to reach the maximum load in approximately 10 min. However the maximum load shall be reached in not less than 5 and not more than 20 min. Record the speed of testing used.

NOTE 5—A constant movable crosshead speed of 0.040 in. (1.0

mm)/min  $\pm$  50 % usually permits reaching the maximum load in the prescribed time.

NOTE 6—The crosshead speed shall mean the free-running, or no-load, crosshead speed for testing machines of the mechanical-drive type, and the loaded crosshead speed for testing machines of the hydraulic-loading type.

9.6 Component Measurements:

9.6.1 Measure the length, width, thickness, and weight of each wood or wood-based connection member to at least three significant digits.

9.6.2 Measure the diameter of the tested bolt using a minimum of one measurement to at least three significant digits.

NOTE 7—A single bolt diameter measurement is judged appropriate to characterize the diameter of most smooth, uncoated bolts. However, additional bolt diameter measurements may be appropriate if the bolts used for the testing are heavily galvanized or are otherwise non-uniform in cross-section.

9.6.3 Measure the actual thickness of any steel member used in the connection to at least three significant figures.

9.6.4 For each wood member of all connections tested, determine the oven-dry specific gravity and moisture content at the time of testing using Test Methods D2395 and D4442, respectively.

9.6.5 For each wood-based member of all connections tested, determine the density and moisture content at the time of testing using Test Methods D2395 and D4442, respectively.

9.6.6 When required to satisfy the test objectives, determine the properties of the bolts by certification or testing using Test Methods F606/F606M on representative bolt samples.

NOTE 8—If the observed failure modes involve bolt yielding, then it may be useful to characterize or verify their yield strength using Test Methods F606/F606M. Measuring the bolt properties may be of marginal

benefit if the test program targets a configuration where bolt yielding is of limited relevance.

10. Interpretation of Results

10.1 Yield Load—To determine the connection yield load, fit a straight line to the initial linear portion of the average load-displacement curve, offset this line by a displacement equal to 5 % of the measured bolt diameter, and select the load at which the offset line intersects the average load-displacement curve (see Fig. 4). In those cases where the offset line does not intersect the average load-displacement curve, the maximum load shall be used as the yield load.

10.2 Proportional Limit Load—The proportional limit load is determined as the load at which the average load-displacement curve deviates from a straight line fitted to the initial linear portion of the curve (see Fig. 4).

10.3 Initial Stiffness—The connection initial stiffness is determined as the slope of the straight line fitted to the initial linear portion of the average load-displacement curve.

11. Report

11.1 Report the following information:

11.1.1 The connection configuration and type of loading (tension or compression) used for testing,

11.1.2 Description of the connection member materials including material type, wood species, wood-based product type, nominal sizes, and material grades,

11.1.3 Description of any wood-based product member including any non-uniformities (i.e., hollow cross-sections or significant density gradients, etc.),

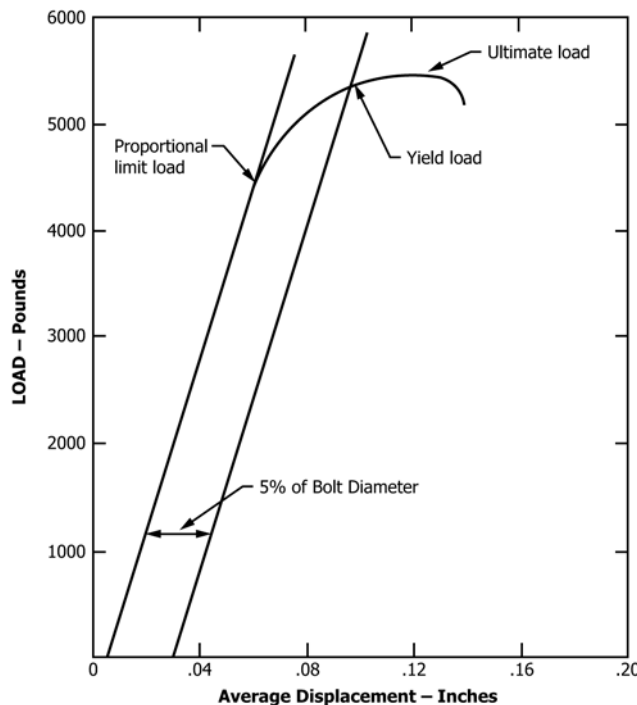

FIG. 4 Definition of Loads to Be Obtained from the Load-Displacement Curve

11.1.4 Description of the wood-based product cross-sectional orientations used for each tested configuration (i.e. bolts positioned perpendicular to the member face or edge), if applicable,

11.1.5 Measured dimensions for each connection member,

11.1.6 Tabulated and plotted data on average load-displacement relationships,

11.1.7 Description of the general behavior of the connection under load, including:

11.1.7.1 Proportional limit,

11.1.7.2 Yield load,

11.1.7.3 Yield mode,

11.1.7.4 Stiffness,

11.1.7.5 Maximum load,

11.1.7.6 Mode of failure,

11.1.8 Bolt-hole diameter,

11.1.9 End and edge distances for each connection member,

11.1.10 Details of loading procedure, including the speed of testing,

11.1.11 Number of replicate tests,

11.1.12 For connections with wood members, the oven-dry specific gravity and moisture content,

11.1.13 For connections with wood-based members, the measured density and moisture content,

11.1.14 Nominal and measured properties and dimensions of the bolts used,

11.1.15 Details of any deviations from the prescribed methods as outlined in these test methods,

11.1.16 Summary statistics for each recorded parameter, including mean, minimum, maximum, and coefficient of variation.

## **12. Precision and Bias**

12.1 The precision and bias of these test methods have not yet been determined.

## **13. Keywords**

13.1 bolts; bolted connections; initial stiffness; wood; wood-based materials

*ASTM International takes no position respecting the validity of any patent rights asserted in connection with any item mentioned in this standard. Users of this standard are expressly advised that determination of the validity of any such patent rights, and the risk of infringement of such rights, are entirely their own responsibility.*

*This standard is subject to revision at any time by the responsible technical committee and must be reviewed every five years and if not revised, either reapproved or withdrawn. Your comments are invited either for revision of this standard or for additional standards and should be addressed to ASTM International Headquarters. Your comments will receive careful consideration at a meeting of the responsible technical committee, which you may attend. If you feel that your comments have not received a fair hearing you should make your views known to the ASTM Committee on Standards, at the address shown below.*

*This standard is copyrighted by ASTM International, 100 Barr Harbor Drive, PO Box C700, West Conshohocken, PA 19428-2959, United States. Individual reprints (single or multiple copies) of this standard may be obtained by contacting ASTM at the above address or at 610-832-9585 (phone), 610-832-9555 (fax), or service@astm.org (e-mail); or through the ASTM website (www.astm.org). Permission rights to photocopy the standard may also be secured from the Copyright Clearance Center, 222 Rosewood Drive, Danvers, MA 01923, Tel: (978) 646-2600; <http://www.copyright.com/>*