



Standard Specification for Adhesives Used for Finger Joints in Nonstructural Lumber Products¹

This standard is issued under the fixed designation D5572; the number immediately following the designation indicates the year of original adoption or, in the case of revision, the year of last revision. A number in parentheses indicates the year of last reapproval. A superscript epsilon (ϵ) indicates an editorial change since the last revision or reapproval.

1. Scope

1.1 This specification establishes performance levels for adhesives to be used in finger joints in nonstructural bonded-lumber products. Such products include, but are not limited to, interior and exterior mouldings, window and door components or parts, and bonded-lumber panels. Adhesives that meet the requirements of the various performance classes are considered capable of providing an adequate bond for use under the conditions described for the class. This specification is to be used to evaluate adhesives as well as the adhesive bonds in the finger joints. See Section 5, Significance and Use, for limitations when using this specification to evaluate industrially manufactured finger joints.

NOTE 1—This specification supersedes the finger-joint portion of the 1990 edition of Specification D3110.

1.2 The following index is provided as a guide to the test methods in this specification:

	Section
Apparatus	6
Equipment, Material, and Preparation of Assemblies and Specimens	7
Conditioning for Factory-Manufactured Assemblies, Laboratory-Made Assemblies, and Test Specimens	8
Testing in Flexure	9
Testing in Tension	10
Exposure Conditions and Treatments	11
1. Dry Use Tests: Dry, 3-cycle Soak, Elevated Temperature, and Temperature-Humidity	11.1
2. Wet Use Tests: Dry, Boil, Elevated Temperature, and Vacuum-Pressure	11.2

NOTE 2—The conditioning needed for various stages in the preparation of both types of specimens and for the exposure tests are given.

NOTE 3—Specific guidelines for specimen size, exposure conditions, testing, calculation, and reporting are given for flexure specimens in Sections 9 and 11, and for tension specimens in Sections 10 and 11.

1.3 For the definitions of *dry use* and *wet use*, see 3.2.1.1 and 3.2.1.2.

1.4 The values stated in inch-pound units are to be regarded as standard. The SI units given in parentheses are for information only.

¹ This specification is under the jurisdiction of ASTM Committee D14 on Adhesives and is the direct responsibility of Subcommittee D14.30 on Wood Adhesives.

Current edition approved Oct. 1, 2012. Published October 2012. Originally approved in 1994. Last previous edition approved in 2005 as D5572 – 95 (2005). DOI: 10.1520/D5572-95R12.

1.5 The following precautionary caveat pertains only to the apparatus and test methods portions, Sections 6 – 11 of this specification: *This standard does not purport to address all of the safety concerns, if any, associated with its use. It is the responsibility of the user of this standard to establish appropriate safety and health practices and determine the applicability of regulatory limitations prior to use.*

2. Referenced Documents

2.1 *ASTM Standards*:²

- D143 Test Methods for Small Clear Specimens of Timber
- D907 Terminology of Adhesives
- D2016 Methods of Test for Moisture Content of Wood (Withdrawn 1987)³
- D3110 Specification for Adhesives Used in Laminate Joints for Nonstructural Glued Lumber Products (Withdrawn 1996)³
- D4688 Test Method for Evaluating Structural Adhesives for Finger Jointing Lumber
- D5266 Practice for Estimating the Percentage of Wood Failure in Adhesive Bonded Joints
- E4 Practices for Force Verification of Testing Machines
- E6 Terminology Relating to Methods of Mechanical Testing
- E41 Terminology Relating To Conditioning
- E177 Practice for Use of the Terms Precision and Bias in ASTM Test Methods
- E691 Practice for Conducting an Interlaboratory Study to Determine the Precision of a Test Method

3. Terminology

3.1 *Definitions*:

- 3.1.1 Many terms in this specification are defined in Terminology D907 and Terminology E41.
- 3.1.2 *bond, n*—the union of materials by adhesives.
- 3.1.3 *finger joint, n*—a joint formed by bonding two precut members shaped like fingers. (See Figs. 1 and 2.)

² For referenced ASTM standards, visit the ASTM website, www.astm.org, or contact ASTM Customer Service at service@astm.org. For *Annual Book of ASTM Standards* volume information, refer to the standard's Document Summary page on the ASTM website.

³ The last approved version of this historical standard is referenced on www.astm.org.

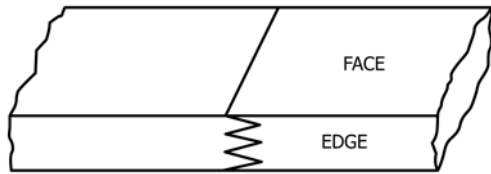

FIG. 1 Horizontal Joint

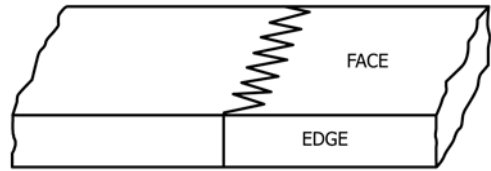

FIG. 2 Vertical Joint

3.2 Definitions of Terms Specific to This Standard:

3.2.1 nonstructural adhesive:

3.2.1.1 *dry use nonstructural adhesive, n*—an adhesive capable of producing sufficient strength and durability to make the bonded lumber product serviceable in nonstructural use, under conditions in which the equilibrium moisture content (EMC) of the wood does not exceed 16 %.

3.2.1.2 *wet use nonstructural adhesive, n*—an adhesive capable of producing sufficient strength and durability to make the bonded lumber product serviceable in nonstructural use, under conditions in which the EMC of the wood may be 16 % or greater.

3.3 Abbreviations:

3.3.1 *EMC*—equilibrium moisture content.

3.3.2 *MC*—moisture content.

4. Test Requirements

4.1 Adhesives:

4.1.1 To comply with this specification the test adhesive shall be tested for performance in accordance with Sections 8.1.1 – 11, and it shall meet the requirements in Table 1 for the selected testing mode and performance classification.

4.1.2 Compliance with this specification shall warrant certification of the adhesive for use on the species of wood that is used for the tests, or for use on a designated group of species when tested and found to be in compliance for any one member of said group of species. The designated species groupings for commonly used domestic and imported woods, as accepted in this specification, are given in Table 2. In the event that the user or supplier of the adhesive, or both, cannot accept the designated groupings in Table 2, either party shall have the option of requesting a test on an individual species. Furthermore, the user and supplier may agree to change any of the wood-failure requirements of Table 1 when applied to tests on Groups 3 and 4 hardwoods from Table 2. For wood-property information on imported woods, see the *Wood Handbook*.⁴

⁴ U.S. Department of Agriculture Forest Service; Agricultural Handbook, No. 72, *Wood Handbook*, Tables 3 and 4, 1987 edition, pp. 3–11.

4.1.2.1 The wood-failure requirements listed in Table 1 are given for softwoods and hardwoods. Table 1 shows that the wood-failure requirements for hardwood are 50 % of the requirements for softwoods.

4.2 *Industrially Manufactured Finger Joint*—An industrially manufactured finger joint may be used to evaluate the adhesive, provided its construction meets the requirements set forth in Sections 7 – 10, and the joint is tested against the requirements in Table 1.

5. Significance and Use

5.1 Adhesives are classified as dry use or wet use. Each classification includes consideration of short-term in-transit exposure conditions at elevated temperatures up to 220°F (104°C).

5.2 The initial development of Specification D3110 was based on finger-joint assemblies made under controlled laboratory conditions. In the development of this revised specification the results obtained with laboratory-made specimens (see 12.1.2) were compared to those obtained with industrially manufactured specimens (see 12.1.1). These finger joints were prepared using previously certified adhesives in cooperation with a manufacturer or equipment supplier who had the necessary finger-joint cutter and assembly equipment. These finger joints may vary in geometry and length from manufacturer to manufacturer, and this variation could affect the performance of the bonded-finger-joint assembly.⁵ (See 12.1, 12.4, and 12.5.) Fig. 3 depicts a sample finger-joint configuration.

5.2.1 When changes are made in the design of the industrially manufactured finger joint, the new design should be compared to a control design that has been used successfully.

5.3 An industrially manufactured finger joint should be evaluated using the requirements for compliance with this specification, in accordance with 4.1. When this specification is used to evaluate specimens made from field-manufactured assemblies, the results may not compare favorably with those run on specimens made from laboratory-made assemblies.

5.4 Test requirements are provided to determine if the adhesive is suitable for dry use or wet use.

5.5 The dry test and exposure conditions and treatments are to evaluate adhesives used in nonstructural finger joints for typical service conditions.

5.5.1 The 220°F (104°C) test, a more severe test, is designed to evaluate the product after exposure to short-term elevated-temperature conditions. This test is intended to simulate conditions that might be experienced in transit, further processing, or in-service conditions.

NOTE 4—These typical service conditions could include stress and time under stress, as well as elevated temperature.

5.6 Procedures are described in sufficient detail to permit duplication in different testing laboratories.

⁵ Selbo, M. L., “Effects of Joint Geometry on Tensile Strength of Finger Joints,” *Forest Products Journal*, Vol 13, No. 9, September 1963, pp. 390–400.

TABLE 1 Minimum Test Requirements

Performance Classification and Exposure Conditions ^A	Subsection Number for Exposure Description	Testing Mode Tension ^B				Testing Mode Flexure	
		Strength, psi (MPa) ^C	Wood Failure ^D		Modulus of Rupture ^C		
			Group Average ^E			Individual Minimum ^F	
			%				Minimum psi (MPa) ^G
		Soft Wood	Hard Wood ^H	Soft Wood	Hard Wood ^H		
Dry Use:							
Cured (dry)	11.1.1	2000 (13.8)	60	30	30	15	2000 (13.8)
Three-cycle soak	11.1.2	1000 (6.9)	30	15	15	/	1000 (6.9)
Elevated Temperature ((220°F (104°C))	11.1.3	1000 (6.9)	/	/	/	/	/
Temperature-Humidity ((140°F (60°C), 16 % EMC))	11.1.4	750 (5.2)	/	/	/	/	/
Wet Use:							
Cured (dry)	11.2.1	2000 (13.8)	60	30	30	15	2000 (13.8)
Boil	11.2.2	1600 (11.0)	50	25	25	/	1400 (9.7)
Elevated Temperature ((220°F (104°C))	11.2.3	1000 (6.9)	/	/	/	/	/
Vacuum Pressure	11.2.4	1600 (11.0)	50	25	25	/	1400 (9.7)

^A Twenty specimens required for each classification and exposure.

^B Parallel to the grain.

^C Tension and flexure results may vary with the species. Any acceptable wood should produce joints able to meet these requirements.

^D The wood-failure requirements are given for softwoods and hardwoods. Groups 3 and 4 hardwoods are listed at 50 % of the softwood value, with no wood-failure requirement if the calculation is 15 % or less. (See 4.1.2.)

^E For total group of specimens tested.

^F For 90 % of the specimens tested, they shall meet or exceed these minimum wood-failure values shown. If a zero value is obtained for any of the specimens (the specimen must meet the strength requirement).

^G For any individual specimen.

^H See recommended minimum specific gravity in Table 2.

^I No requirement.

5.6.1 Record any deviations in these procedures on the report forms, **Appendix X1**, as it may have an impact on the results obtained. Test data are only valid for the length and design used. (See 12.4.)

5.7 To avoid potential problems that would be caused by interrupting the bonding process, the adhesive-performance level should be determined by the finger-joint manufacturer prior to handling and early shipment. Before beginning the full testing process, the testing laboratory should pull a representative sample and check the dry strength first, in order to ensure that the product basically conforms with the performance level certified by the adhesive manufacturer.

TEST METHODS

6. Apparatus

NOTE 5—The finger-joint specimens to be broken in tension are shorter than those to be broken in flexure. Accommodation must be made in the equipment for handling the larger flexure specimen.

6.1 *Environmental Chamber (For Moist-Heat Aging)*, capable of conditioning specimens at $80 \pm 5^\circ\text{F}$ ($27 \pm 3^\circ\text{C}$) and $80 \pm 5\%$ relative humidity and capacity for at least 20 specimens well-spaced and supported on racks to allow free air flow.

6.2 *Oven(s)*, with sufficient air circulation to remove moisture from the chamber, and capable of meeting all the following temperature requirements: $105 \pm 5^\circ\text{F}$ ($41 \pm 3^\circ\text{C}$) (see 11.1.2); 220 and $230 \pm 5^\circ\text{F}$ (104 and $110 \pm 3^\circ\text{C}$) (see 11.1.3 and 11.2.3); $150 \pm 2^\circ\text{F}$ ($65 \pm 1^\circ\text{C}$) (see 11.1.4); and $145 \pm 5^\circ\text{F}$ ($63 \pm 3^\circ\text{C}$) (see 11.2.2).

6.3 *Tank for Soaking*, capacity to meet the requirements of 11.1.2, so that all of the specimens are at least 2 in. (50.8 mm) below the water level for the duration of the soak cycles.

6.4 *Tank for Boiling*, capacity to meet the requirements of 11.2.2, so that all of the specimens are at least 2 in. (50.8 mm) below the water level for the duration of the boil cycles.

6.5 *Testing Machine for the Flexure Specimen*, capacity of not less than 2200 lbf (1000 kgf) in compression, equipped for one-third span, two-point loading as described in 9.5 and shown in Fig. 4, capable of maintaining a uniform rate of loading such that the load may be applied with a continuous motion of the movable head to maximum at a rate of 0.5 in. (11.7 mm)/min with a permissible variation of $\pm 10\%$, and located in an atmosphere such that the moisture content of the specimens developed under the conditions prescribed in Section 11 is not noticeably altered during testing.

6.6 *Testing Machine for the Tension Specimen*, capable of applying a calibrated tensile force, equipped with grips of sufficient length to hold the specimen firmly, preferably a minimum length of 2.5 in. (63.5 mm) by a width of 0.75 in. (19 mm), and capacity of both test machine and grips of not less than 2200 lbf (1000 kgf).

NOTE 6—Depending on the design and adaptability, the same machine with a 2200-lbf (1000-kgf) capacity, described in 6.5 for the flexure testing, can be used for the tension test described in 6.6. (See Practices E4 and Terminology E6.)

6.7 *Vacuum-Pressure Vessel*, capable of meeting the requirements of 11.2.4, and capacity to meet the requirement that all

TABLE 2 Bondability Groupings of Commonly Used Domestic and Imported Wood^A

U.S. Hardwoods	U.S. Softwoods	Imported Woods	
Group 1—Bond Easily^B			
Alder	Cedar, incense	Balsa	Hura
Aspen	Fir:	Cativo	Purpleheart
Basswood	White	Courbaril	Roble
Cottonwood	Grand	Determa ^C	
Chestnut, American	Noble		
Magnolia	Pacific		
Willow, black	Pine:		
	Eastern white		
	Western white		
	Redcedar, western		
	Redwood		
	Spruce, Sitka		
Group 2—Bond Well^D			
Butternut	Douglas-fir	Afrormosia	Meranti (lauan):
Elm:	Larch, western ^E	Andiroba	White
American	Pine:	Angelique	Light red
Rock	Sugar	Avodire	Yellow
Hackberry	Ponderosa	Banak	Obeche
Maple, soft	Redcedar, eastern	Iroko	Okoume
Sweetgum		Jarrah	Opepe
Sycamore		Limba	Peroba rosa
Tupelo		Mahogany:	Sapele
Walnut, black		African	Spanish-cedar
Yellow-poplar		True	Sucupira
			Wallaba
Group 3—Bond Satisfactory^F			
Ash, white	Alaska-cedar	Angelin	Meranti (lauan), dark red
Beech, American	Port-Orford-cedar	Azobe	Pau marfim
Birch:	Pine, southern	Benge	Parana-pine
Sweet		Bubinga	Pine:
Yellow		Karri	Caribbean
Cherry			Radiata
Hickory:			Ramin
Pecan			
True			
Madrone			
Maple, hard			
Oak:			
Red ^C			
White ^C			
Group 4—Bond With Difficulty^G			
Osage-orange		Balata	Keruing
Persimmon		Balau	Lapacho
		Greenheart	Lignumvitae
		Kaneelhart	Rosewood
		Kapur	Teak

^A From *Wood Handbook*⁷ Table 9-1 (with the species incense cedar added to Group 1) U.S. Forest Service, USDA, Washington, DC. Although this table is of historical significance, it is recognized that more modern adhesives might lead to different species groupings in regard to difficulty of bonding. The user is referred to 5.2.

^B Bond very easily with adhesives of a wide range of properties and under a wide range of bonding conditions.

^C Difficult to bond with phenol-formaldehyde adhesive.

^D Bond well with a fairly wide range of adhesives under a moderately wide range of bonding conditions.

^E Wood from butt logs with high extractive content are difficult to bond.

^F Bond satisfactorily with good-quality adhesives under well-controlled bonding conditions.

^G Satisfactory results require careful selection of adhesives and very close control of bonding conditions; may require special surface treatment.

of the specimens are at least 2 in. (50.8 mm) below the water level for the duration of the complete vacuum-pressure cycles.

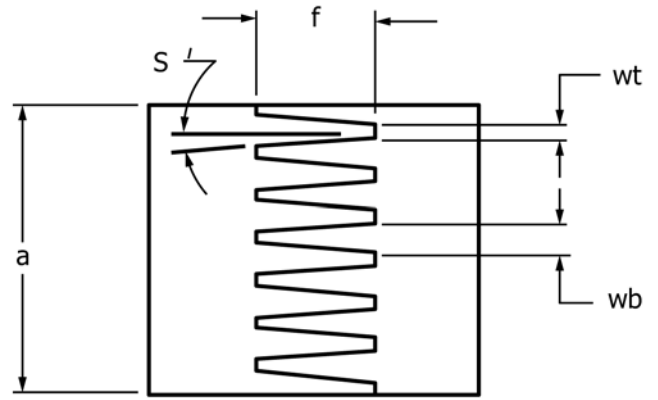

Example Dimensions for Fig. 3 Test Standard Finger Joint:

Code	Dimensions, in. (mm) ^A	Degrees
a	1.312 (33.32)	...
f	0.250 (6.25)	...
wt	0.047 (1.19)	...
wb	0.092 (2.34)	...
s (Slope)		5°

^A The dimensions given are for a typical horizontal finger joint and are examples only.

FIG. 3 Test Standard Finger-Joint Form

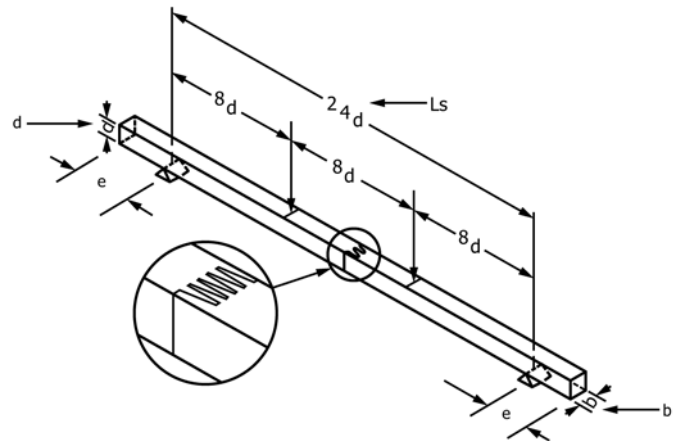

Example Dimensions for Fig. 4 Flexure Test Specimen:

Code	Dimension, in. (mm) ^A
Ls	12.0 (307.2)
b	0.75 (19.2)
d	0.5 (12.8)
e	(see 9.2.1)

^A These dimensions are given as examples of a finger-joint assembly. Use the actual measurements of "b" and "d." Code "b" may be the width of a vertical joint, or the thickness of a horizontal joint. Code "e" is the extended dimension of the length of the assembly that falls outside the reaction points.

FIG. 4 Flexure Test Form and Dimension

7. Preparation of Finger Joint

7.1 *Equipment*—Prepare the finger-joint assemblies in cooperation with a wood-products manufacturer, an equipment manufacturer, or a laboratory having all of the proper equipment.

7.2 Preparation of Assemblies:

7.2.1 *Material*—Use lumber that conforms to the requirements: maximum slope of grain of 1 in 14 on any face or edge; EMC of 8 to 12 %, preferably brought to 10 to 12 % MC prior to cutting and bonding; free of knots and decay; free of machining defects such as chipped grain, feed-roll polish, coarse knife marks, and feed-roll compression; free of drying effects, such as case hardening, collapse, or splits or checks. Recommended minimum specific gravities are given in **Table 3**. Finger joints are to be cut on the day the assemblies are to be made. See **4.1.2** for species compliance rules relative to testing, and **Table 2** for information on the bondability of some species of wood.

7.2.2 *Adhesive*—Follow the adhesive manufacturer’s instructions for conditions and procedures for preparing and applying the adhesive, as well as for assembling, pressing, and curing the assembly.

7.2.3 *Number of Specimens*—For each unique combination of specimen type, mode of testing, and exposure condition, a test group consists of 20 specimens, representing at least four different assemblies with no more than five specimens from each assembly.

8. Conditioning

8.1 *Measuring Moisture Content*—There are several stages in this test method where it is necessary to determine the MC as follows: on the lumber before bonding, on the assemblies before cutting into specimens, and on the specimens during several tests when they must be dried to a given MC before testing.

8.1.1 *Factory-Manufactured Assemblies*—When constructing the assemblies, select lumber within the range from 10 to 12 % MC before bonding, (see **7.2.1**). Determine the MC by use of an electronic moisture meter, in accordance with Test Method B in Methods **D2016**. After bonding the assemblies in the field, control the MC of the specimens throughout the testing process as shown in **8.1.2.1** and **8.1.3** for laboratory-made specimens.

8.1.2 *Laboratory-Made Assemblies*—Select lumber as described in **7.2.1**, except determine the MC of the lumber by Test Method A, Oven-Dry; or by Test Method B, Electronic Moisture Meter Method, of Methods **D2016**, when agreement within ± 1 % MC with Test Method A has been determined.

8.1.2.1 If needed, condition the assemblies to the original MC, ± 1 % MC, by use of an environmental chamber (see **6.1**) prior to cutting the specimens.

8.1.3 *Specimen Conditioning During the Testing Process*—The allowable variation in MC at the completion of a drying cycle or before testing dry is ± 1 % MC. For example, if the MC of the specimen before exposure is 9 %, the acceptable range for testing is 8 to 10 %. Wood failure is estimated on specimens after they have been conditioned to less than 8 %, except for the dry test described in **11.1.1** and **11.2.1**, where the specimens have never been taken from the dry state. Wood failure may be read on these test specimens following the strength testing, with no further conditioning to reduce MC.

9. Testing in Flexure

9.1 *Conditioning*—Follow instructions in Section 8.

9.2 *Preparation of Test Specimen*:

9.2.1 *Form and Dimension*—From a finger-jointed assembly (see **7.2**), cut the flexure-test specimens with sufficient length for the joint to be centered at midspan as in **Fig. 4**, and with a distance between reaction points of 24 multiplied by the depth, *d*. Allow at least 1 in. (25 mm) at both ends of the specimen outside the reaction points. On each edge of the specimen, feather out the finger at the midpoint of the joint, adjusting the width of the specimen accordingly. (See **Fig. 5**.)

NOTE 7—In this application, “to feather” means to remove any portion extending beyond the normal surface of the outer finger so that the stress riser (butt joint effect) is not present on the surface. See **Fig. 5**.

9.3 *Exposure Conditions*—Subject the specimens to the tests for the selected wet-use or dry-use classification, or both, in accordance with the applicable conditions and treatments given in Section 11. Consult **Table 1** for the tests required for each testing mode and performance classification.

9.4 *Testing Machine*—See **6.5**.

9.5 *Testing Procedure*—Apply the load with a continuous motion of the movable head at a rate of 0.5 in. (12.7 mm)/min (± 10 %), testing the specimens by one-third span, two-point loading with the load applied perpendicular to the face showing the fingers, as shown in **Fig. 4**.

9.6 *Calculation*—Calculate the modulus of rupture in pounds-force per square inch or kilopascals as follows:

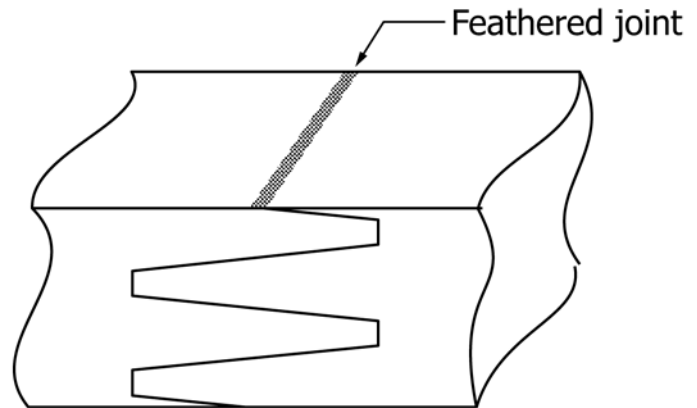

FIG. 5 Feathered Finger Joint

TABLE 3 Recommended Minimum Specific Gravities by Species

Species	Specific Gravity ^{A,B}
Douglas Fir, East	0.48
Douglas fir, Interior South	0.46
Cedar, Alaska	0.44
Fir, White	0.39
Hemlock, Western	0.45
Larch, Western	0.52
Pine, Lodgepole	0.41
Pine, Loblolly	0.51
Pine, Ponderosa	0.40

^A Values have been taken from Table 4-2, *Wood Handbook*.⁷

^B Values are averages based on oven-dry weight and volume at 10 to 12 % moisture content.

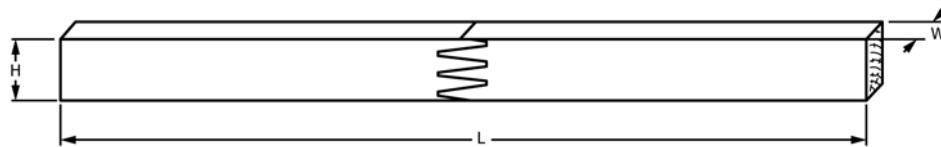

Example Dimensions for Fig. 6:

(L)	10 in. (254.0 mm) ^{A,B}
(H)	0.75 in. (19.05 mm)
(W)	0.25 in. (6.35 mm)

^A The dimensions are given as examples only.

^B The recommended length is 10 in. Some testing machines cannot accommodate this length. See Note 7.

FIG. 6 Tension Test Multifinger Form and Dimension

$$R = P/lbd^2 \quad (1)$$

where:

- R = modulus of rupture, psi (MPa),
- P = maximum load, lbf (N),
- l = length of span (24d), in. (mm),
- b = breadth of specimen, in. (mm), and
- d = depth of specimen, in. (mm).

9.7 *Report*—Report the modulus of rupture values on the form shown in Fig. X1.1 for dry use and wet use. Also, report the wood species used for testing, indicate whether it is classified as soft wood or hard wood, and report the slope of the finger in degrees. Report the measurements for b and d , to the nearest 0.01 in. (0.25 mm) for each specimen. Fig. X1.1 also includes spaces for the recording of several items of bonding information that, although not required for test reporting, have been found useful in product quality control.

10. Testing in Tension

10.1 *Conditioning*—Follow the instructions in Section 8.

10.2 *Preparation of Test Specimen*:

10.2.1 *Form and Dimensions*—From a finger-jointed assembly, cut the tension test specimens, with each measuring 0.25 by 0.75 ± 0.01 in. (6.35 by 19.05 ± 0.25 mm), with a recommended length of 10 in. (25.4 cm). Trim the outer fingers of the specimen as described in Note 7 and as shown in Fig. 5, a process known in this specification as “feathering.” (See 9.2.1 and Note 7.)

NOTE 8—Fig. 6 illustrates a sample finger-joint configuration. Ten inches (25.4 cm) is the preferred length, but shorter lengths may be necessary to accommodate certain testing machines. (See 5.5.1.)

10.3 *Exposure Conditions*—Follow the instructions in Section 11. See Table 1 for the tests required for each testing mode and performance classification.

10.4 *Testing Machine*—See 6.6.

10.5 *Testing*—Apply the load at a rate of 0.5 in. (12.7 mm)/min.

10.6 *Calculation*—Calculate the ultimate tensile stress in pounds-force per square inch or megapascals based on tensile breaking load and the cross-sectional area at the finger joint.

10.7 *Report*—Report the tensile-stress values together with the estimated percentages of wood failure on the form shown in X1.2 for dry use or X1.3 for wet use. Indicate whether the

assemblies were field-manufactured or laboratory-made. Also, report the wood species and indicate whether it is classified as soft wood or hard wood. Report the slope of the finger in degrees and the dimensions to the nearest 0.01 in. (0.25 mm) for each specimen: length of the finger (f), width of the finger at the tip (wt), and width of the finger at the base (wb). See Fig. 3.

10.7.1 Estimate the wood failure on the finger joints by eye to the nearest 5 %. In addition, the mode and location of failure may be noted, that is, as wood failure away from the joint, through the tips, or following the fingers. See Appendixes X6 and X7 for guidelines on reading wood failure.

11. Exposure Conditions and Treatments

NOTE 9—Due to the number of specimens to be tested and the type of tests that must be run, there may not be sufficient time to run all the specimens at one time in the time allotted. So that the time schedule may be followed, before running the tests in 11.1.3, 11.2.2, 11.2.3, and 11.2.4, determine whether 1 h is enough time to test 20 specimens. If not, divide the specimens into smaller groups before running the exposure tests.

11.1 *Dry Use*—The exposure conditions and treatments used with each testing mode to meet the dry-use classification requirements are listed in Table 1. See 8.1.3 for information on allowable MC when testing the specimens. See 10.7.1 for instructions on reading wood failure. Details of the test methods are given as follows:

11.1.1 *Dry Test*—Following the prescribed curing period for the adhesive being tested, condition or dry one group of the specimens (see 7.2.2) to within the allowable range of ±1 % MC of the original MC (see 8.1.3), and test in accordance with the instructions in 9.5 or 10.5.

11.1.2 *Soak Test (Three Cycle)*—Place one group of the specimens (see 7.2.2) in the soak tank, separated by stickers, wire screens, or other means, in such a manner that all surfaces are freely exposed to the water. Weight down the specimens in water at 65 to 80°F (19 to 27°C) so that all specimens are at least 2 in. (50.8 mm) below the surface of the water. Keep the specimens immersed for a period of 4 h, followed by drying at a temperature of 105 ± 5°F (41 ± 3°C) for a period of 19 h, with sufficient air circulation to reduce the moisture content of specimens to within ±1 % MC of the original MC as described in 8.1.3. Repeat this procedure twice more for a total of three cycles. Following the third cycle, conduct the tests in the dry condition at 75 ± 5°F (24 ± 3°C). If needed before testing and reading wood failure, condition or dry to less than 8 % MC, in

an environmental chamber. (See 8.1.3.) Use of an electronic moisture meter, as described in 8.1.1, is acceptable to determine MC.

11.1.3 *Elevated Temperature Test*—Use either of the following test methods:

11.1.3.1 *Test Method Number One*—Place one group of specimens (see 7.2.3) in an oven at $220 \pm 5^\circ\text{F}$ ($104 \pm 3^\circ\text{C}$) and hold for 6 h. Remove the specimens individually and immediately wrap each in two layers of PVDC wrap.⁶ Place wrapped specimens in a single layer in an oven at $230 \pm 5^\circ\text{F}$ ($110 \pm 3^\circ\text{C}$), and hold for a minimum of 12 min and maximum of 22 min. Remove them from the oven one specimen at a time, and test within 30 s, without removing the PVDC wrap. Conduct the test in a room with an ambient temperature of $75 \pm 5^\circ\text{F}$ ($24 \pm 3^\circ\text{C}$).

NOTE 10—The exposure of the unwrapped specimens for 6 h at $220 \pm 5^\circ\text{F}$ ($104 \pm 3^\circ\text{C}$), is for the purpose of simulating an elevated temperature environment that could be encountered during transportation. Polyvinylidene chloride wrap slows the cooling rate while testing. This method has been corroborated by a laboratory that participated in the round robins.

NOTE 11—Using this procedure, the temperature of a specimen 15 s after removal from the oven will be approximately 220°F (104°C). The cool-down rate was based on actual tests of specimens.

11.1.3.2 *Test Method Number Two*—Test the specimens for the effect of elevated temperature by using a heated chamber that is capable of heating the specimens to $220 \pm 5^\circ\text{F}$ ($104 \pm 3^\circ\text{C}$) for 6 h, and also enclosing the testing machine for testing immediately following the exposure period. (See 6.2.)

11.1.4 *Temperature-Humidity Test*—Condition one group of specimens (see 7.2.3) to equilibrium at $80 \pm 5^\circ\text{F}$ ($27 \pm 3^\circ\text{C}$) and $80 \pm 5\%$ relative humidity (equivalent to 16 % EMC).⁷ Wrap each specimen in two layers of PVDC wrap and place in a single layer in oven at $150 \pm 2^\circ\text{F}$ ($65 \pm 1^\circ\text{C}$) for 12 to 20 min. In a room with an ambient temperature of $75 \pm 2^\circ\text{F}$ ($24 \pm 1^\circ\text{C}$), remove specimens one at a time and test within 30 s without removing the PVDC wrap.

11.2 *Wet Use*—The exposure conditions and treatments used with each testing mode to meet the wet-use classification requirements are listed in Table 1. See 8.1.3 for information on allowable MC when testing the specimens. See 10.7.1 for instructions on reading wood failure. Details of the test methods are given as follows:

11.2.1 *Dry Test*—Follow the instructions in 11.1.1.

11.2.2 *Boil Test*—Place one group of specimens (see 7.2.3) in a tank of boiling water, separated by stickers, wire screens, or other means, in such a manner that all surfaces are freely exposed to the water. Weight down the specimens so they remain immersed at least 2 in. (50.8 mm) during the boil cycle. Boil for 4 h. Dry for 20 h at $145 \pm 5^\circ\text{F}$ ($63 \pm 3^\circ\text{C}$) with sufficient air circulation to lower the MC of the specimens to the original MC, within an allowable variation of $\pm 1\%$ MC. (See 8.1.3.) Determine the MC by removing a specimen at 18,

19, and 20 h and testing with a moisture meter until the MC reading is in the desired range, or predetermine the time required to reach the desired MC by running samples. Repeat the 4-h boil cycle. Then remove the specimens and cool in running water at 65 to 80°F (18 to 27°C) for 1 h. Remove the specimens from the water and place them in a plastic bag to keep them wet. Test while wet within 1 h.

11.2.2.1 For the specimens broken in tension, dry to less than 8 % MC before estimating the percentage of wood failure. Use of an electronic moisture meter, as described in 8.1.1, is acceptable to determine MC.

11.2.3 *Elevated-Temperature Test*—Follow the instructions in 11.1.3.

11.2.4 *Vacuum-Pressure Test*—Place one group of specimens (see 7.2.3) in a pressure vessel, separated by stickers, wire screens, or other means in such a manner that all surfaces can be freely exposed to the water. Weight down the specimens, and fill the vessel with water at 65 to 80°F (18 to 27°C) so that all specimens are immersed at least 2 in. (51 mm). Draw and maintain a vacuum of at least 25 in. Hg (84.4 kPa) for 30 min. Release the vacuum, and follow immediately with pressure of 75 ± 2 psi (517 ± 14 kPa) for 30 min. Remove the specimens from the vessel and place in a plastic bag to keep them wet. Test while wet within 1 h. (See Note 9.) Dry to less than 8 % MC as described in 8.1.3 before reading wood failure. Use of an electronic moisture meter, as described in 8.1.1, is acceptable to determine MC.

12. Precision and Bias

12.1 The precision of these tests on finger joints tested in tension was determined by a series of round-robin tests. The data were analyzed using the procedure in accordance with Practice E691. Factors carefully controlled were: wood species, finger-joint configuration, cutting-tool condition, adhesive, and bonding condition. The data generated by these round robins are available.⁸

12.1.1 A round-robin test to determine repeatability and reproducibility was run on field-manufactured specimens. This test was compared to two earlier round-robin tests where the specimens were made under controlled laboratory conditions. The repeatability and reproducibility of the tensile-strength data on the field-manufactured specimens were an improvement over that obtained on the laboratory-made specimens. The repeatability and reproducibility of the wood-failure data on the field-manufactured specimens generally showed more variability when compared to that of laboratory-made specimens.⁸

12.1.2 Table 4 gives the results of the study on laboratory-made specimens, expressed as the coefficient of variation ($CV\%$) within a laboratory (repeatability), and ($CV\%_R$) between laboratories (reproducibility). The research report⁸ gives the maximum and minimum tensile strengths and wood failures for all tests run for Round Robins 1 and 2 on laboratory-made specimens. The research report⁸ compares the

⁶ PVDC (polyvinylidene chloride) wrap is the generic designation for the tightly adhering, flexible films commonly used for covering food containers in the home.

⁷ Forest Products Laboratories, "Wood Handbook: Wood as an Engineering Material," *Agriculture Handbook*, No. 72, Washington, DC: U.S.D.A.; Rev. 1987. Tables 3 and 4, pp. 3–11, "Moisture Content of Wood in Equilibrium with Stated Dry Bulb Temperature and Relative Humidity."

⁸ Supporting data have been filed at ASTM International Headquarters and may be obtained by requesting Research Report RR:D14-1005. Contact ASTM Customer Service at service@astm.org.

TABLE 4 Tensile-Strength and Wood-Failure Precision

	Tensile Strength		Wood Failure	
	CV % _r ^A	CV % _R ^B	CV % _r ^A	CV % _R ^B
Dry	72.6	74.5	31.5	32.8
Boil	42.0	66.1	129.5	155.5
Vacuum-Pressure	60.9	68.3	79.9	86.6
165°F (74°C)	52.9	63.2	120.8	137.3
220°F (104°C)	49.7	62.7	188.1	220.8

^A Repeatability, coefficient of variation in percent (within a laboratory).

^B Reproducibility, coefficient of variation in percent (between laboratories).

repeatability and reproducibility of the data on the field-manufactured specimens to that of the laboratory-made specimens.

12.2 Practice E691 allows reporting of results in a number of different ways. Coefficient of variation (CV) was chosen in this instance because the mean varied so much that comparing standard deviations did not give a clear picture. Using CV's illustrates the larger standard deviation in comparison to the means.

12.3 An explanation of the preferred indexes of precision for ASTM test methods is given in 28.1 and 28.2 of Practice E177. These paragraphs include the calculations for the coefficients of variation for both CV %_r and CV %_R. CV %_r and CV %_R are larger than the coefficient of variation (*s/n*), calculated as shown in Note 12. (See Appendix X2 for the pertinent excerpts from Practice E177.)

NOTE 12—The coefficient of variation that has been historically used by the industry is calculated by the formula:

$$CV = s/n \quad (2)$$

where:

- CV = coefficient of variation,
- s* = standard deviation, and
- n* = mean.

12.3.1 In this specification, Committee D14 has chosen to use the preferred indexes of precision for ASTM test methods, as given in Practice E177.

12.4 For the laboratory-made specimen (see Appendix X2), when finger lengths were 0.3 and 1.0 in. (7.6 and 25.4 mm),

length did not appear to influence the precision of either the tensile strength or wood failure. The estimation of wood failure by the various participating laboratories was determined not to be a source of variation.

12.5 On the laboratory-made specimens, the main source of imprecision was within, rather than between, the individual laboratories. This indicates that the primary sources of variability may be attributed to specimen factors such as wood density, wood strength, wood-grain slope, and testing conditions.

12.6 To determine a base precision, samples of clear wood were prepared and broken in accordance with Test Methods D143 and analyzed in accordance with Practice E691. Table 5 gives the results of this study.

12.6.1 The repeatability within laboratories obtained from clear-wood specimens is consistent with that of the laboratory-made finger-joint specimens. This suggests that the results from the finger-joint round-robin test show the repeatability that is achievable within a laboratory.

12.6.2 The reproducibility between laboratories obtained from the clear-wood specimens as compared with laboratory-made finger-joint specimens, illustrates that this may be the best reproducibility achievable on bonded specimens.

12.7 No precision has been determined for finger joints broken in flexure.

12.8 These test methods have no measure of bias since the tensile strength and wood failure are defined by the testing methods.

13. Keywords

13.1 adhesive; bonded; dry use; finger joint; flexure; non-structural; tension; wet use

TABLE 5 Clear-Wood Tensile Precision

Tensile Strength, psi	14 500
CV % _r ^A	46.2
CV % _R ^B	61.6

^A Repeatability, coefficient of variation in percent (within a laboratory).

^B Reproducibility, coefficient of variation in percent (between laboratories).

APPENDIXES

(Nonmandatory Information)

X1. REPORT FORMS

X1.1 The following report forms in Fig. X1.1, Fig. X1.2, and Fig. X1.3 are used to record test results and to provide an easy reference to determine whether the specimens prepared

with the test adhesive pass the requirements of this specification. A supplementary page is provided in Fig. X1.4 for recording information needed for interpretation of the results.

Report No. _____
 Adhesive Manufacturer _____
 Testing Facility _____
 Laboratory No. _____

Type Test	MODULUS OF RUPTURE, DRY USE				MODULUS OF RUPTURE, WET USE					
	Dry 11.1.1		3-Cycle Soak 11.1.2		Dry 11.2.1		Boil 11.2.2		Vacuum Pressure 11.2.4	
	Strength Total Group		Strength Total Group		Strength Total Group		Strength Total Group		Strength Total Group	
	psi	(MPa)	psi	(MPa)	psi	(MPa)	psi	(MPa)	psi	(MPa)
1	-----	-----	-----	-----	-----	-----	-----	-----	-----	-----
2	-----	-----	-----	-----	-----	-----	-----	-----	-----	-----
3	-----	-----	-----	-----	-----	-----	-----	-----	-----	-----
4	-----	-----	-----	-----	-----	-----	-----	-----	-----	-----
5	-----	-----	-----	-----	-----	-----	-----	-----	-----	-----
6	-----	-----	-----	-----	-----	-----	-----	-----	-----	-----
7	-----	-----	-----	-----	-----	-----	-----	-----	-----	-----
8	-----	-----	-----	-----	-----	-----	-----	-----	-----	-----
9	-----	-----	-----	-----	-----	-----	-----	-----	-----	-----
10	-----	-----	-----	-----	-----	-----	-----	-----	-----	-----
11	-----	-----	-----	-----	-----	-----	-----	-----	-----	-----
12	-----	-----	-----	-----	-----	-----	-----	-----	-----	-----
13	-----	-----	-----	-----	-----	-----	-----	-----	-----	-----
14	-----	-----	-----	-----	-----	-----	-----	-----	-----	-----
15	-----	-----	-----	-----	-----	-----	-----	-----	-----	-----
16	-----	-----	-----	-----	-----	-----	-----	-----	-----	-----
17	-----	-----	-----	-----	-----	-----	-----	-----	-----	-----
18	-----	-----	-----	-----	-----	-----	-----	-----	-----	-----
19	-----	-----	-----	-----	-----	-----	-----	-----	-----	-----
20	-----	-----	-----	-----	-----	-----	-----	-----	-----	-----
Avg	-----	-----	-----	-----	-----	-----	-----	-----	-----	-----
A Avg	2000	(13.8)	1000	(6.9)	2000	(13.8)	1400	(9.7)	1400	(9.7)
B WF%	XXX		XXX		XXX		XXX		XXX	
Passed	_____		_____		_____		_____		_____	
Meets Dry Use Requirement	Yes ___ No ___		Yes ___ No ___		Meets Wet Use Requirement		Yes ___ No ___		Yes ___ No ___	

A Required minimum average strength for total group of specimens in psi (MPa).

B No wood failure requirement.

Test Specimens*
 MOR ___ in(b) × ___ in(d)
 × ___ in(Ls)
 Fingers (f) ___ in
 Width, tip (wt) ___ in
 Width, base(wb) ___ in
 *Slope (s) _____

*See FIG. 3.

FIG. X1.1 Modulus of Rupture, Dry Use and Wet Use

Report No. _____
 Adhesive Manufacturer _____
 Testing Facility _____
 Laboratory No. _____

Type Test	Dry			3-Cycle Soak		
	Strength Total Group	11.1.1		Strength Total Group	11. 1.2	
		(A) Wood Failure			(A) Wood Failure	
		Soft Wood	Hard Wood		Soft Wood	Hard Wood
		Total Group	Total Group		Total Group	Total Group
psi or (MPa)	%	%	psi or (MPa)	%	%	
1	-----	-----	-----	-----	-----	-----
2	-----	-----	-----	-----	-----	-----
3	-----	-----	-----	-----	-----	-----
4	-----	-----	-----	-----	-----	-----
5	-----	-----	-----	-----	-----	-----
6	-----	-----	-----	-----	-----	-----
7	-----	-----	-----	-----	-----	-----
8	-----	-----	-----	-----	-----	-----
9	-----	-----	-----	-----	-----	-----
10	-----	-----	-----	-----	-----	-----
11	-----	-----	-----	-----	-----	-----
12	-----	-----	-----	-----	-----	-----
13	-----	-----	-----	-----	-----	-----
14	-----	-----	-----	-----	-----	-----
15	-----	-----	-----	-----	-----	-----
16	-----	-----	-----	-----	-----	-----
17	-----	-----	-----	-----	-----	-----
18	-----	-----	-----	-----	-----	-----
19	-----	-----	-----	-----	-----	-----
20	-----	-----	-----	-----	-----	-----
Avg	-----	-----	-----	-----	-----	-----
B Avg	2000 (13.8)	XXX	XXX	1000 (6.9)	XXX	XXX
C WF% Total	XXX	60	30	XXX	30	15
D WF% Min.	XXX	30	15	XXX	15	E
Passed	-----	-----	-----	-----	-----	-----
Meets Dry Use Requirement	Yes _____		No _____			

- A Place a check alongside the minimum wood failure value.
- B Required minimum average strength for total group of specimens in psi(MPa).
- C Required minimum average % wood failure for total group of specimens.
- D Required minimum % wood failure for individual specimen. (See Table 1, Footnote F.)
- E No wood failure requirement.

FIG. X1.2 Report Form for Finger Joints—Tension, Dry Use (Part 1)

Report No. _____
 Adhesive Manufacturer _____
 Testing Facility _____
 Laboratory No. _____

Type Test	220°F(104°C)			140°F (60°C)		
	Strength Total Group	11.1.3		Strength Total Group	11.1.4	
		(A) Wood Failure			(A) Wood Failure	
		Soft Wood	Hard Wood		Soft Wood	Hard Wood
		Total Group	Total Group		Total Group	Total Group
psi or (MPa)	%	%	psi or (MPa)	%	%	
1	-----	-----	-----	-----	-----	-----
2	-----	-----	-----	-----	-----	-----
3	-----	-----	-----	-----	-----	-----
4	-----	-----	-----	-----	-----	-----
5	-----	-----	-----	-----	-----	-----
6	-----	-----	-----	-----	-----	-----
7	-----	-----	-----	-----	-----	-----
8	-----	-----	-----	-----	-----	-----
9	-----	-----	-----	-----	-----	-----
10	-----	-----	-----	-----	-----	-----
11	-----	-----	-----	-----	-----	-----
12	-----	-----	-----	-----	-----	-----
13	-----	-----	-----	-----	-----	-----
14	-----	-----	-----	-----	-----	-----
15	-----	-----	-----	-----	-----	-----
16	-----	-----	-----	-----	-----	-----
17	-----	-----	-----	-----	-----	-----
18	-----	-----	-----	-----	-----	-----
19	-----	-----	-----	-----	-----	-----
20	-----	-----	-----	-----	-----	-----
Avg	-----	-----	-----	-----	-----	-----
B Avg	1000 (6.9)	XXX	XXX	750 (5.2)	XXX	XXX
C WF% Total	XXX	E	E	XXX	E	E
D WF% Min. Passed	XXX	E	E	XXX	E	E
Meets Dry Use Requirement		Yes _____		No _____		

- A Place a check alongside the minimum wood failure value.
- B Required minimum average strength for total group of specimens in psi(MPa).
- C Required minimum average % wood failure for total group of specimens.
- D Required minimum % wood failure for individual specimen.
(See Table 1, Footnote F.)
- E No wood failure requirement.

FIG. X1.2 Report Form for Finger Joints—Tension, Dry Use (Part 2) (continued)

Report No. _____
 Adhesive Manufacturer _____
 Testing Facility _____
 Laboratory No. _____

Type Test	Dry			Boil		
	Strength Total Group psi or (MPa)	11.2.1		Strength Total Group psi or (MPa)	11.2.2	
		(A) Wood Failure %			(A) Wood Failure %	
		Soft Wood	Hard Wood		Soft Wood	Hard Wood
	Total Group	Total Group	Total Group	Total Group	Total Group	
	%	%	%	%	%	
1	-----	-----	-----	-----	-----	-----
2	-----	-----	-----	-----	-----	-----
3	-----	-----	-----	-----	-----	-----
4	-----	-----	-----	-----	-----	-----
5	-----	-----	-----	-----	-----	-----
6	-----	-----	-----	-----	-----	-----
7	-----	-----	-----	-----	-----	-----
8	-----	-----	-----	-----	-----	-----
9	-----	-----	-----	-----	-----	-----
10	-----	-----	-----	-----	-----	-----
11	-----	-----	-----	-----	-----	-----
12	-----	-----	-----	-----	-----	-----
13	-----	-----	-----	-----	-----	-----
14	-----	-----	-----	-----	-----	-----
15	-----	-----	-----	-----	-----	-----
16	-----	-----	-----	-----	-----	-----
17	-----	-----	-----	-----	-----	-----
18	-----	-----	-----	-----	-----	-----
19	-----	-----	-----	-----	-----	-----
20	-----	-----	-----	-----	-----	-----
Avg	-----	-----	-----	-----	-----	-----
B Avg	2000 (13.8)	XXX	XXX	1600 (11.0)	XXX	XXX
C WF% Total	XXX	60	30	XXX	50	25
D WF% Min. Passed	XXX	30	15	XXX	25	E
Meets Wet Use Requirement		Yes _____		No _____		

- A Place a check alongside the minimum wood failure value.
- B Required minimum average strength for total group of specimens in psi(MPa).
- C Required minimum average % wood failure for total group of specimens.
- D Required minimum % wood failure for individual specimen. (See Table 1, Footnote F.)
- E No wood failure requirement.

FIG. X1.3 Report Form for Finger Joints—Tension, Wet Use (Part 1)

Report No. _____
 Adhesive Manufacturer _____
 Testing Facility _____
 Laboratory No. _____

Type Test	220°F (104°C)			Vacuum Pressure		
	11.2.3			11.2.4		
	Strength Total Group	(A) Wood Failure %		Strength Total Group	(A) Wood Failure %	
		Soft Wood	Hard Wood		Soft Wood	Hard Wood
psi or (MPa)	Total Group	Total Group	psi or (MPa)	Total Group	Total Group	
	%	%		%	%	
1	_____	_____	_____	_____	_____	_____
2	_____	_____	_____	_____	_____	_____
3	_____	_____	_____	_____	_____	_____
4	_____	_____	_____	_____	_____	_____
5	_____	_____	_____	_____	_____	_____
6	_____	_____	_____	_____	_____	_____
7	_____	_____	_____	_____	_____	_____
8	_____	_____	_____	_____	_____	_____
9	_____	_____	_____	_____	_____	_____
10	_____	_____	_____	_____	_____	_____
11	_____	_____	_____	_____	_____	_____
12	_____	_____	_____	_____	_____	_____
13	_____	_____	_____	_____	_____	_____
14	_____	_____	_____	_____	_____	_____
15	_____	_____	_____	_____	_____	_____
16	_____	_____	_____	_____	_____	_____
17	_____	_____	_____	_____	_____	_____
18	_____	_____	_____	_____	_____	_____
19	_____	_____	_____	_____	_____	_____
20	_____	_____	_____	_____	_____	_____
Avg	_____	_____	_____	_____	_____	_____
B Avg	1000 (6.9)	XXX	XXX	1600 (11.0)	XXX	XXX
C WF% Total	XXX	E	E	XXX	50	25
D WF% Min. Passed	XXX	E	E	XXX	25	E
Meets Wet Use Requirement		Yes _____		No _____		

- A Place a check alongside the minimum wood failure value.
- B Required minimum average strength for total group of specimens in psi(MPa).
- C Required minimum average % wood failure for total group of specimens.
- D Required minimum % wood failure for individual specimen. (See Table 1, Footnote F.)
- E No wood failure requirement.

FIG. X1.3 Report Form for Finger Joints—Tension, Wet Use (Part 2) (continued)

Report No. _____

Date _____

Adhesive Manufacturer _____

Testing Facility _____

Laboratory No. _____

Species Used _____

Hard Wood _____ Check one

Soft Wood _____ Check one

Adhesive Used _____

Field Mfg. _____ Check one

Laboratory Made _____ Check one

Date Bonded _____

Date Received _____

Tested by _____

Adhesive mix, spread, pressing conditions and comments -----

Test Specimens*

Fingers (f) _____ in (_____ mm)

Width at Tip (wt) _____ in (_____ mm)

Width at Base (wb) _____ in (_____ mm)

*Slope (s) _____

* See FIG 2.

FIG. X1.4 Supplementary Information for Use With Fig. X1.2 and Fig. X1.3

X2. EXCERPTS FROM PRACTICE E177

X2.1 Several terms that are used in this specification are defined in Practice E177 and are shown as follows for reference. The subsection number from Practice E177 is shown following the definition.

X2.1.1 *bias, n*—a generic concept related to a consistent or systematic difference between a set of test results from the process and an accepted reference value of the property being measured. (See X1.1.3 of Practice E177.)

X2.1.2 *precision, n*—a generic concept related to the closeness of agreement between test results obtained under prescribed like conditions from the measurement process being evaluated. (See X1.1.5 of Practice E177.)

X2.1.3 *repeatability, n*—a general term for a measure of precision applicable to the variability between test results obtained within a single laboratory in the shortest practical period of time by a single operator with a specific set of test apparatus using test specimens taken at random from a single sample of material. (See X1.1.6 of Practice E177.)

X2.1.4 *reproducibility, n*—a general term for a measure of precision applicable to the variability between single test results obtained in different laboratories using test specimens taken at random from a single sample of material. (See X1.1.7 of Practice E177.)

X2.2 The following excerpts from Practice E177 express indexes in percent, and also explain both the preferred types of precision and the preferred indexes, as well as the recommended terminology for preferred indexes. Note that $CV\%_r$ and $CV\%_R$ are larger than the coefficient of variation historically used. See Note 12.

X2.2.1 *Indexes in Percent*—In some instances (see section 28.5 of Practice E177) there may be some advantage in expressing the precision index as a percentage of the average test results; that is, percent coefficient of variation ($CV\%$). The notation may then be ($CV\%$) ($2CV\%$), ($d2CV\%$), etc. (See 27.3.5 of Practice E177.)

X2.2.2 *Preferred Types of Precision and Preferred Indexes*—The types of precision described in 23.1.3 and 25.1, namely, repeatability and reproducibility, are the preferred types of precision statements for ASTM test methods. The preferred index for each of these types is the 95 % limit on the difference between the two test results (see section 27.3.3 of Practice E177), namely, 2.8 s or 2.8 $CV\%$. Also the corresponding standard deviation(s) or percent coefficient of variation ($CV\%$) shall be indicated. (See 28.1 of Practice E177.)

X2.2.3 *Recommended Terminology for Preferred Indexes*— $r = 95\%$ repeatability limit, and $R = 95\%$ reproducibility limit.

X2.2.3.1 To help prevent confusion between the r and R , use $r = 95\%$ repeatability limit (within a laboratory), and $R = 95\%$ reproducibility limit (between laboratories).

X2.2.3.2 Similarly, the recommended terminology for the corresponding standard deviations is: s_r = repeatability standard deviation (within a laboratory), and s_R = reproducibility standard deviation (between laboratories). For the coefficients of variation $CV\%_r$ = repeatability coefficient of variation in percent (within a laboratory), and $CV\%_R$ = reproducibility coefficient of variation in percent (between laboratories).

where:

$$r = 1.960 \sqrt{2} s_r = 2.8 s_r \text{ or } r = 1.960 2CV\%_r = 2.8CV\%_r,$$

and

$$R = 1.960 \sqrt{2} s_R = 2.8 s_R \text{ or } R = 1.960 2CV\%_R = 2.8CV\%_R$$

depending on how the indexes vary with the test level (see section 28.5 of Practice E177).

X2.2.3.3 For other than the preferred types, the more general terminology “95 % limit” may be used with the sources of variability, for example: 95 % limit (operator-to-operator, within-laboratory), and similarly for the corresponding standard deviation: operator-to-operator within laboratory standard deviation (see section 28.2 of Practice E177).

X3. EXCERPT FROM TEST METHOD D4688

X3.1 The following excerpt was taken from Annex A1 of Test Method D4688. Although it was mandatory information in Test Method D4688, it is published here as nonmandatory background information on the various classifications of wood failure in finger joints broken in tension:

X3.1.1 The types of failure that occur in finger-jointed specimens due to tension loading may be roughly classified into six modes. Determine the failure mode of each specimen based on the written and graphical description given in Fig. X3.1.

X3.1.2 Failure Modes 1 and 2 require the evaluator to make a distinction between less than 70 % wood failure and more than 70 % wood failure. This is often a difficult quantity to judge from an oblique angle. In difficult cases it is suggested that the fingers be cut off at their roots so that the failed surfaces of the finger can be viewed directly.



Mode	Description	Example
1	Failure mostly along the bondline surfaces of the joint profile with poor wood failure of any kind (wood failure < 70%).	
2	Failure mostly along the bondline surfaces of the joint profile with good wood shear failure (wood failure > 70%).	
3	Failure mostly along the joint profile but with some failure at the finger roots or scarf tips. Good overall wood shear failure along the joint profile surfaces.	
4	Mostly tensile wood failure at the fingerjoint roots or scarf tips and with high overall wood failure. Little failure of any kind along the joint profile.	
5	Failure beginning at the joint (possibly due to a stress riser) and progressing away from the joint. Essentially 100% wood failure.	
6	Failure away from the joint (not influenced by the joint)--all wood failure.	

FIG. X3.1 Failure Mode Criteria

X4. EXCERPT FROM PRACTICE D5266

X4.1 The following excerpt was taken from the sections of Practice D5266 as shown, with the source of each subsection given following the text:

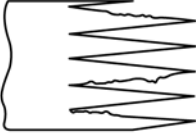
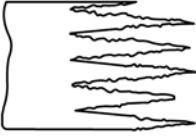
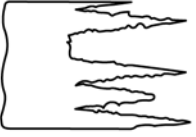
Section	Heading
5	Apparatus
6	Preparation of Specimen
7	Procedure
8	Evaluation of Wood Failure

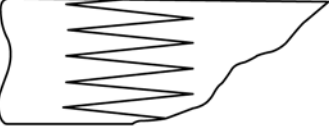
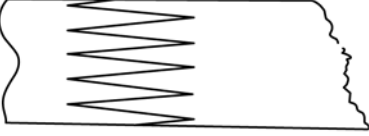
NOTE X4.1—Practice D5266 was written primarily with plywood or a laminate-bonded joint in mind, but many of the directions also apply to reading the wood failure of finger joints.

X4.1.1 *Apparatus*—A dual-element desk lamp equipped with one 15-W daylight and one 15-W cool white tube is recommended as a light source. (See 5.1.1 of Practice D5266.)

X4.1.2 *Preparation of Test Specimens*—Do not estimate the wood failure percentage of specimens with localized defects such as knots, knotholes, burl, and voids in the bonded area. (See 6.2 of Practice D5266.)

X4.1.3 *Procedure*:

X4.1.3.1 Work in a location where direct outside light does not fall on the specimen. (See 7.1 of Practice D5266.)

X4.1.3.2 Select a light source and use it consistently. (See 7.2 of Practice D5266.)

X4.1.3.3 When reading wood failure on finger joints, hold the specimen with the length of the fingers perpendicular to the line between the light source and the eye. (See 7.4.3 of Practice D5266.)

X4.1.3.4 Dyes are sometimes helpful in distinguishing wood failure from light-colored adhesive. (See 7.6.1 of Practice **D5266**.)

X4.1.3.5 Magnification, rotation of the specimen, and variation of the incident angle of the light on the surface are often necessary to distinguish shallow wood failure from adhesive failure, especially when the adhesive is light colored or transparent. Magnification may or may not be used to make the actual estimate of wood failure, however the practice should be consistent. After rotation always reposition the specimen to the standard position before making the estimate of wood failure. (See 7.6.2 of Practice **D5266**.)

X4.1.3.6 Mentally divide the surface into quadrants for estimating the areas of various forms of failure. (See 7.1 of Practice **D5266**.)

X4.1.3.7 Estimate total wood-fiber failure of each specimen to the nearest 5 %, with a maximum of 100 % of the total bonded test area. (See 7.11 of Practice **D5266**.)

X4.1.4 *Evaluation of Wood Failure:*

X4.1.4.1 For accuracy and consistency special care must be taken in the middle range from 30 to 85 %, where most of the difficulty occurs. (See 8.1 of Practice **D5266**.)

X4.1.4.2 The color of the adhesive and recognition of shallow wood failure affect the estimate. (See 8.2 of Practice **D5266**.)

X4.1.4.3 If the percentage of wood failure is high and the failure is mostly on the side of the adhesive layer, the grain orientation may be a factor. (See 8.3 of Practice **D5266**.)

X4.1.4.4 Record any indications of poor spread, lack of adhesive transfer, or other bonding problems. (See 8.4 of Practice **D5266**.)

ASTM International takes no position respecting the validity of any patent rights asserted in connection with any item mentioned in this standard. Users of this standard are expressly advised that determination of the validity of any such patent rights, and the risk of infringement of such rights, are entirely their own responsibility.

This standard is subject to revision at any time by the responsible technical committee and must be reviewed every five years and if not revised, either reapproved or withdrawn. Your comments are invited either for revision of this standard or for additional standards and should be addressed to ASTM International Headquarters. Your comments will receive careful consideration at a meeting of the responsible technical committee, which you may attend. If you feel that your comments have not received a fair hearing you should make your views known to the ASTM Committee on Standards, at the address shown below.

This standard is copyrighted by ASTM International, 100 Barr Harbor Drive, PO Box C700, West Conshohocken, PA 19428-2959, United States. Individual reprints (single or multiple copies) of this standard may be obtained by contacting ASTM at the above address or at 610-832-9585 (phone), 610-832-9555 (fax), or service@astm.org (e-mail); or through the ASTM website (www.astm.org). Permission rights to photocopy the standard may also be secured from the Copyright Clearance Center, 222 Rosewood Drive, Danvers, MA 01923, Tel: (978) 646-2600; <http://www.copyright.com/>