



Standard Test Method for Determination of Residual Acrylonitrile Monomer in Styrene-Acrylonitrile Copolymer Resins and Nitrile-Butadiene Rubber by Headspace-Capillary Gas Chromatography (HS-CGC)¹

This standard is issued under the fixed designation D5508; the number immediately following the designation indicates the year of original adoption or, in the case of revision, the year of last revision. A number in parentheses indicates the year of last reapproval. A superscript epsilon (ϵ) indicates an editorial change since the last revision or reapproval.

1. Scope*

1.1 This test method covers the determination of the residual acrylonitrile (RAN) content in nitrile-butadiene rubbers (NBR), styrene-acrylonitrile (SAN) copolymers, and rubber-modified acrylonitrile-butadiene-styrene (ABS) resins.

1.2 Any components that can generate acrylonitrile in the headspace procedure will constitute an interference. The presence of 3-hydroxypropionitrile in latices limits this procedure to dry rubbers and resins.

1.3 The values stated in SI units are to be regarded as standard. No other units of measurement are included in this standard.

1.4 *This standard does not purport to address all of the safety concerns, if any, associated with its use. It is the responsibility of the user of this standard to establish appropriate safety and health practices and determine the applicability of regulatory limitations prior to use.* Specific precautionary statements are given in 6.3 and 6.4.

NOTE 1—There is no known ISO equivalent to this standard.

2. Referenced Documents

2.1 *ASTM Standards*:²

[E691 Practice for Conducting an Interlaboratory Study to Determine the Precision of a Test Method](#)

3. Summary of Test Method

3.1 Two dispersions (in o-dichlorobenzene) are prepared and sealed in headspace vials for each polymer; one vial contains the polymer in solvent while the second vial contains

the polymer, solvent, plus a known standard addition of acrylonitrile (AN). Both vials are agitated for a specified time under ambient conditions. After agitation, the vials are thermally equilibrated in a constant-temperature bath.

3.2 After completion of the timed equilibration, an aliquot of the heated headspace gas from each vial is injected into a capillary gas-chromatographic column using an automated injection system. The capillary column will provide the chromatographic resolution necessary to isolate the AN from other volatiles potentially present. The AN response is measured using a nitrogen-specific detector (NPD). The raw data signal is converted to a relative RAN concentration through a standard addition calculation.

4. Significance and Use

4.1 A measurement of the residual acrylonitrile in nitrile rubbers (NBR), styrene-acrylonitrile copolymers or ABS terpolymers will determine the polymer's suitability for various applications.

4.2 Under optimum conditions, the minimum level of detection of RAN in NBR, SAN, or ABS terpolymers is approximately 50 ppb.

5. Apparatus

5.1 *Gas Chromatograph*, equipped with a nitrogen-phosphorus specific detector, backflush valve (see Fig. 1), split injector, and capable of accepting megabore (0.53 mm inside diameter) fused silica capillary columns. Detector make-up gas is required.

NOTE 2—The use of a backflush configuration will provide for operating advantages, but its use is optional. Chlorinated solvents quench the alkali bead in a nitrogen-phosphorous detector, producing a loss of signal. While the bead (signal) will recover as the solvent evacuates the detector, repeated quenching during a multi-run sequence may produce instabilities in the signal (and precision) over the sequence period.

5.2 *Automated Headspace Sampler*, shall have a thermostatted sample tray capable of 90°C heating with constant heating times. Automated sampling of the headspace gas in the sample vials via a heated, constant-volume sample loop or

¹ This test method is under the jurisdiction of ASTM Committee D20 on Plastics and is the direct responsibility of Subcommittee D20.70 on Analytical Methods and Section D20.70.02 on Chromatography.

Current edition approved Sept. 1, 2016. Published September 2016. Originally approved in 1994. Last previous edition approved in 2009 as D5508 - 94a(2009)^{ε1}. DOI: 10.1520/D5508-16.

² For referenced ASTM standards, visit the ASTM website, www.astm.org, or contact ASTM Customer Service at service@astm.org. For *Annual Book of ASTM Standards* volume information, refer to the standard's Document Summary page on the ASTM website.

*A Summary of Changes section appears at the end of this standard

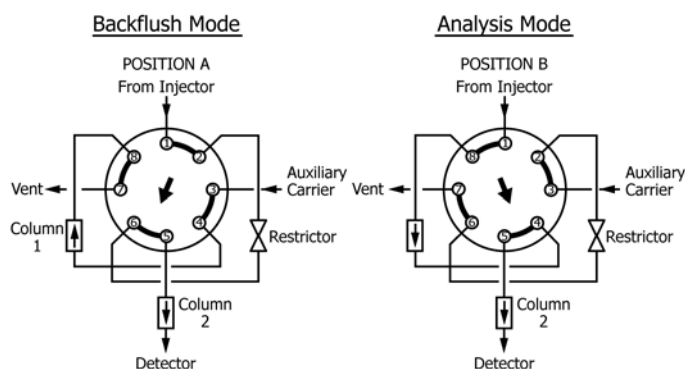

FIG. 1 Configuration of Eight-Port Valve Backflush Assembly

pressure balancing sampling mechanism is required. Conduct sampling to the gas chromatograph by means of a heated transfer line of minimum dead volume.

5.3 *Fused Silica Porous-Layer-Open-Tubular (PLOT) Capillary Column*, 30 m × 0.53 mm inside diameter.

NOTE 3—The column should be cut so as to have a 3 m section for the pre-column (Column 1) and a 27-m section for the analytical column (Column 2).

5.4 *Variable Restrictor*.

5.5 *Data-Recording Device*—A strip-chart recorder, recording integrator, or computer-based data system is suitable.

5.6 *Wrist-Action Shaker*.

5.7 *Analytical Balance*, 0.1-mg readability.

5.8 *Headspace Vials*, 20-mL capacity.

5.9 *Aluminum Crimp Caps*, 20-mm diameter.

5.10 *Septa*, TFE-fluorocarbon-faced silicone construction, 20-mm diameter.

5.11 *Crimper*; for 20-mm crimp caps.

6. Reagents and Materials

6.1 *Purity of Reagents*—Chemicals of the highest purity shall be used in all tests. Solvents shall have a minimum of volatile impurities. Other grades shall only be used after ascertaining that the reagent is free of interferences.

6.2 Observe all health and safety recommendations for each chemical, as prescribed by the manufacturer.

6.3 *Acrylonitrile*, 99 + %. (**Warning**—Acrylonitrile is an OSHA-regulated carcinogen and should not be released into the laboratory atmosphere. All work involving acrylonitrile should be carried out in a hood or with proper personal protection to minimize human exposure.)

6.4 *o-Dichlorobenzene*. (**Warning**—*o*-Dichlorobenzene is moderately toxic and should only be handled in a hood or with proper personal protection to limit human exposure.)

NOTE 4—Each lot of *o*-dichlorobenzene should be analyzed under the same instrumental conditions as the NBR samples to ensure that impurities are not present that will interfere with the acrylonitrile peak.

7. Sampling and Storage

7.1 The polymer test unit (sample) submitted for analysis shall be supplied in the form of a 1³/₄ in. (45 mm) cube.

7.2 All test specimens shall be taken from the interior of the polymer-test unit to minimize the contribution of surface effects on the residual-acrylonitrile level.

7.3 Keep all polymer-test units in sealed containers. Analyze test-specimen solutions immediately after preparation. Report any analysis delays along with the test results.

8. Calibration

8.1 *Preparation of External Standard Solutions:*

8.1.1 Tare (to the nearest 0.1 mg) a 25-mL volumetric flask containing 10 mL of *o*-dichlorobenzene (DCB).

8.1.2 Weigh (to the nearest 0.1 mg) into the 25-mL volumetric flask 40 ± 5 mg of AN. Dilute to the mark with DCB. Label this solution as the “external-standard master solution”.

8.1.3 Add 1 mL of the “external-standard master solution” to a clean 10-mL volumetric flask containing 2 mL of DCB. Dilute to the mark with additional DCB. Label this solution as the “external-standard working solution”.

8.1.4 Prepare fresh “master” and “working” solutions each week and keep refrigerated at 4°C using Parafilm “M” to seal volumetric stoppers.

8.2 *Generation of the External-Standard Calibration Curve:*

NOTE 5—A new external-standard calibration curve should be generated each week to account for any changes in the AN response due to NPD bead fluctuations.

8.2.1 Transfer 5 mL of DCB into seven clean headspace vials, using a volumetric pipet.

8.2.2 Add 0 (solvent blank), 1, 5, 10, 20, 60, or 100 µL of the “external-standard working solution”, respectively, to the vials.

8.2.3 Seal each vial immediately after addition with a septum and crimp cap.

8.2.4 Establish the instrument parameters as listed in Annex A1.

8.2.5 Obtain the peak-area values for AN in each of the standards.

9. Procedure

9.1 *Determine the Target AN Weight for Polymer Test Units:*

9.1.1 Weigh (to the nearest 0.1 mg) into a clean headspace vial 400 ± 10 mg of polymer. Add 5 mL of DCB, using a volumetric pipet. Seal vial with septum and crimp cap.

9.1.2 Place the vial on a wrist-action shaker, set at maximum agitation for 16 h under ambient conditions.

9.1.3 Analyze the sample under the same instrument parameters as was used to generate the external-standard calibration curve.

9.1.4 Obtain the peak-area value for AN.

9.2 *Preparation of AN Standard-Addition Solution:*

NOTE 6—The following steps in preparing the AN standard addition solution are given as an illustration only. Depending on the target weights involved, the AN concentration of these solutions may need to be adjusted.

9.2.1 Tare (to the nearest 0.1 mg) a 25-mL volumetric flask containing 10 mL of DCB.

9.2.2 Weigh (to the nearest 0.1 mg) into the 25-mL volumetric flask 165 ± 10 mg of AN. Dilute to the mark with DCB. Label this solution as the “AN master solution”.

9.2.3 Add 50 μ L of the “AN master solution” to a clean 10-mL volumetric flask containing 2 mL of DCB. Dilute to the mark with DCB. Label this solution as the “AN working solution”. This solution has an AN concentration of 33 ng/ μ L.

9.2.4 Prepare fresh “master” and “working” solutions weekly or as needed for varying target levels. Keep refrigerated at 4°C using Parafilm “M” to seal volumetric stoppers.

9.3 Determination of the RAN Concentration:

NOTE 7—At this point, it must be decided which type of determination is required: (1) *Linearity Test*—Required for each different polymer type as it is encountered. Once the linearity of the standard addition has been established it may be assumed valid for further analyses for that specific polymer type. (2) *Precision Test*—Required for each different polymer type as it is encountered. Once the precision of the standard addition has been established it may be assumed valid for further analyses for that specific polymer type. (3) *Routine Test*—Both linearity and precision have been established for the specific polymer type to be tested. Only a routine RAN determination is required.

9.3.1 Weigh (to the nearest 0.1 mg) into a clean headspace vial 400 ± 10 mg of polymer. Add 5 mL of DCB to the vial, using a volumetric pipet. Loosely place the septum and crimp cap on the vial. Do not seal at this time.

9.3.1.1 For a *Linearity Test*—Prepare eight vials with the identical weight (± 5 mg) of polymer in each vial.

9.3.1.2 For a *Precision Test*—Prepare a minimum of twelve vials with the identical weight (± 5 mg) of polymer in each vial.

9.3.1.3 For a *Routine Test*—Prepare two vials per polymer test specimen with the identical weight (± 5 mg) of polymer in each vial.

9.3.2 Add to each vial a volume of the “AN working solution,” resulting in a weight of AN based on the target weight as specified below for each test.

9.3.2.1 For a *Linearity Test*—Add 0, 0.25, 0.5, 1, 2, 3, 4, and five times the target AN weight to the vials, respectively.

9.3.2.2 For a *Precision Test*—Make no addition to six vials and an addition of three times the target AN weight to the other six vials.

NOTE 8—This group of vials is to be run as six sets each containing one from the null addition and three times the target weight. The pairing is carried through the calculations.

9.3.2.3 For a *Routine Test*—Make no addition to one vial and an addition of three times the target AN weight to the remaining vial.

9.3.3 Seal vials with crimper (immediately after an addition).

9.3.4 Place the vials on a wrist-action shaker, set at maximum agitation for 16 h under ambient conditions.

9.3.5 Establish the instrument parameters as listed in Annex A1.

9.3.6 Obtain the peak-area values for AN from each vial.

10. Calculations

10.1 External-Standard-Calibration Curve:

10.1.1 Plot AN added (ng) versus AN peak area (seven data points obtained from 8.2.5).

10.1.2 Perform a linear regression on the data set. The inverse of the slope, 1/slope, will be the AN-response factor with units of ng/unit area.

10.2 Target AN weight:

10.2.1 Calculate the target AN weight in ng for the polymer:

$$TW, (ng) = A(sp) \times RF \tag{1}$$

where:

$A(sp)$ = peak area for AN in polymer test specimen (from 9.1.4), and

RF = external-response factor for AN from the external-calibration curve in ng/unit area (from 10.1.2).

10.3 RAN Concentration:

10.3.1 Linearity Test:

10.3.1.1 Plot AN added (ng) versus AN peak area (eight data points obtained from 9.3.6) to obtain a curve as illustrated in Fig. 2.

10.3.1.2 Perform a linear regression on the data set. The correlation coefficient will determine the degree of linearity for the specific polymer type. The absolute value of the x-intercept will give the weight of AN in the polymer.

NOTE 9—The degree of linearity increases as the correlation coefficient nears a value of 1.

10.3.1.3 Calculate the RAN concentration for the polymer in parts per billion (ng/g):

$$RAN, (ppb) = \frac{|x - intercept|}{W(sp)} \tag{2}$$

where:

$|x - intercept|$ = absolute value of the x-intercept obtained from the linear regression (nanograms), and

$W(sp)$ = weight (grams) of NBR (polymer).

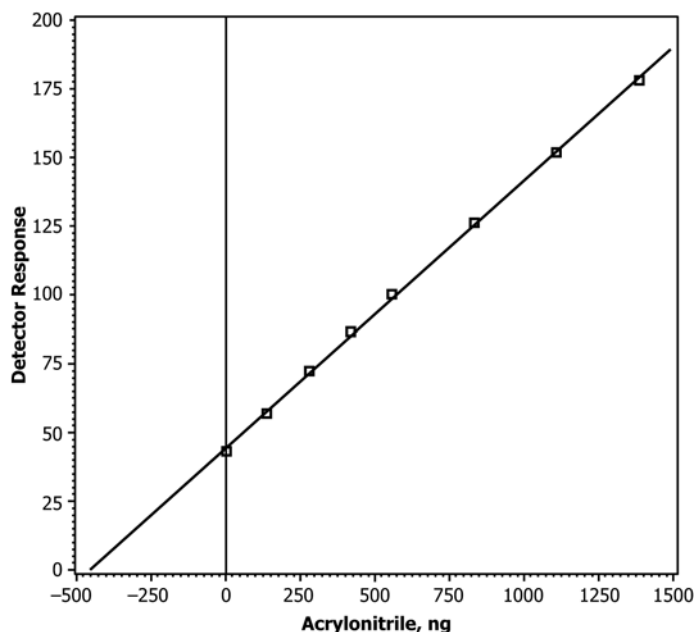

FIG. 2 Plot of Detector Response Versus Nanograms Acrylonitrile Added

10.3.2 Precision Test:

10.3.2.1 Plot AN added (ng) versus AN peak-area values for the six pairs of data points obtained from 9.3.6. Six lines will be plotted.

10.3.2.2 Perform a linear regression on each of the six pairs of data points. Determine the *x*-intercept for each pair (six values total).

10.3.2.3 Calculate the RAN concentration using each *x*-intercept value. Refer to 10.3.1.3.

10.3.2.4 Calculate the mean for the six RAN values obtained above. Determine the standard deviation (*s*) for the data set. The precision will be expressed as the percent relative standard deviation (%RSD).

$$\%RSD = \frac{s}{\text{mean RAN value}} \times 100 \quad (3)$$

10.3.3 Routine Test:

10.3.3.1 Plot AN added (ng) versus AN peak area values (two points obtained from 9.3.6).

10.3.3.2 Perform a linear regression on the data set. The absolute value of the *x*-intercept will be the weight (ng) of AN in the polymer.

10.3.3.3 Calculate the RAN concentration for the polymer in parts per billion (ng/g). Refer to 10.3.1.3.

11. Report

11.1 Report parts per billion (ng/g) residual acrylonitrile monomer.

12. Precision and Bias

NOTE 10—Data were generated only for nitrile rubbers, although comparable repeatability can be expected for SAN and ABS resins.

12.1 Precision statements were prepared in accordance with Practice E691.

12.2 Ten materials (NBRs) of varying levels of the test component were used in the interlaboratory program. Materials “A” through “E” were 30 to 37 % AN NBRs, and materials “A” through “E” were 40 to 48 % AN NBRs. Testing was conducted in four laboratories.

12.3 No valid statement of between-laboratories reproducibility is acceptable for data from less than six laboratories. However, within-laboratory repeatability precision values are shown in Table 1.

NOTE 11—Laboratories interested in performing between labs reproducibility round-robin testing should contact ASTM headquarters.

12.3.1 The concept of the “*r*” and “(*r*)” values (repeatability limits) in Table 1 is as follows: when comparing two test results for the same material obtained by the same operator using the same equipment on the same day, judge the two test results as not equivalent if they differ by more than the “*r*” or “(*r*)” value for that material.

12.3.2 Any judgement in accordance with 12.3.1 would have an approximate 95 % (0.95) probability of being correct.

12.4 Bias—By definition, bias is a measure of the systematic error that contributes to the difference between the mean value of the test-result population and an accepted reference or true value. It is possible that one or more bias elements contribute to the systematic error.

12.5 No statement of bias is made for this test method due to the lack of an absolute method for comparison.

13. Keywords

13.1 headspace-gas chromatography; nitrile rubber; residual acrylonitrile; styrene-acrylonitrile copolymers

TABLE 1 Type I—Precision (Residual Acrylonitrile in Nitrile-Butadiene Rubber)

Material	Mean, ppm	Within Laboratories		
		<i>sr</i> ^A	<i>r</i> ^B	(<i>r</i>) ^C
A	0.66	0.07	0.20	30.5
B	1.25	0.13	0.35	28.4
C	1.12	0.23	0.64	57.7
D	0.17	0.04	0.11	67.7
E	0.16	0.05	0.13	82.5
“A”	1.84	0.07	0.19	10.3
“B”	0.66	0.04	0.12	17.9
“C”	38.5	2.06	5.77	15.0
“D”	10.8	0.73	2.04	18.9
“E”	1.25	0.12	0.34	27.3

^A *sr* = Within-laboratory standard deviation.

^B *r* = Repeatability (in measurement units).

^C (*r*) = Repeatability (in percent).

ANNEX

(Mandatory Information)

A1. PARAMETERS FOR GAS CHROMATOGRAPH AND HEADSPACE SAMPLER

A1.1 Gas Chromatograph Parameters:

A1.1.1 Injection Mode—Capillary, split.

A1.1.2 Injection Temperature—250°C.

A1.1.3 Carrier Gas—Helium.

A1.1.4 Linear Flow Velocity—38 cm/s (at approximately 130°C).

A1.1.5 Oven Temperature Profile—Isothermal, 155°C.

A1.1.6 Detector Type—Nitrogen-phosphorus detector.

A1.1.7 Detector Temperature—300°C.

TABLE A1.1 Parameters for Gas Chromatograph and Headspace Sampler

Time min:s	Action	Description
:01	Probe	Needle enters vial
:03	Pressure	Vial pressurization begins
:18	Pressure	Vial pressurization stops
:19	Vent/fill loop	Initialize sample loop filling
:28	Vent/fill loop	Close sample loop-loop filled
:33	Inject	Flush sample onto analytical column
1:03	Vent/fill loop	Open loop to vent
1:04	Pressure	Initialize sample loop cleaning
2:34	Pressure	Stop carrier flow through sample loop
2:35	Vent/fill loop	Close vent
2:36	Inject	Stop injection cycle
2:37	Probe	Needle exits vial

A1.2 Headspace Sampler Parameters:
A1.2.1 Bath Temperature—90°C.
A1.2.2 Equilibration Time—3 hour.
A1.2.3 Sample Loop Size—3 mL.
A1.2.4 Sample Loop Temperature—110°C.
A1.2.5 Injection Cycle Parameters—(For volume-controlled headspace sampler).
SUMMARY OF CHANGES

Committee D20 has identified the location of selected changes to this standard since the last issue (D5508 - 94a(2009)^{e1}) that may impact the use of this standard. (September 1, 2016)

- (1) Updated ISO equivalency statement.
- (2) Removed product-specific references throughout document.

ASTM International takes no position respecting the validity of any patent rights asserted in connection with any item mentioned in this standard. Users of this standard are expressly advised that determination of the validity of any such patent rights, and the risk of infringement of such rights, are entirely their own responsibility.

This standard is subject to revision at any time by the responsible technical committee and must be reviewed every five years and if not revised, either reapproved or withdrawn. Your comments are invited either for revision of this standard or for additional standards and should be addressed to ASTM International Headquarters. Your comments will receive careful consideration at a meeting of the responsible technical committee, which you may attend. If you feel that your comments have not received a fair hearing you should make your views known to the ASTM Committee on Standards, at the address shown below.

This standard is copyrighted by ASTM International, 100 Barr Harbor Drive, PO Box C700, West Conshohocken, PA 19428-2959, United States. Individual reprints (single or multiple copies) of this standard may be obtained by contacting ASTM at the above address or at 610-832-9585 (phone), 610-832-9555 (fax), or service@astm.org (e-mail); or through the ASTM website (www.astm.org). Permission rights to photocopy the standard may also be secured from the Copyright Clearance Center, 222 Rosewood Drive, Danvers, MA 01923, Tel: (978) 646-2600; http://www.copyright.com/