



Standard Practice for Identification of Polymer Layers or Inclusions by Fourier Transform Infrared Microspectroscopy (FT-IR)¹

This standard is issued under the fixed designation D5477; the number immediately following the designation indicates the year of original adoption or, in the case of revision, the year of last revision. A number in parentheses indicates the year of last reapproval. A superscript epsilon (ϵ) indicates an editorial change since the last revision or reapproval.

1. Scope

1.1 This practice describes the techniques used for detecting two different polymer entities as follows:

1.1.1 Abnormal specks or spots on a surface or in the film that are objectionable as defects and

1.1.2 Layers of different polymeric sheets commonly used as barrier films made by coextrusion.

1.2 The values stated in SI units are to be regarded as the standard. The values given in parentheses are for information only.

1.3 *This standard does not purport to address all of the safety concerns, if any, associated with its use. It is the responsibility of the user of this standard to establish appropriate safety and health practices and determine the applicability of regulatory limitations prior to use.* Specific hazard statements are given in Section 7.

NOTE 1—There is no known ISO equivalent to this standard.

2. Referenced Documents

2.1 *ASTM Standards:*²

D883 Terminology Relating to Plastics

D1248 Specification for Polyethylene Plastics Extrusion Materials for Wire and Cable

D1600 Terminology for Abbreviated Terms Relating to Plastics

E131 Terminology Relating to Molecular Spectroscopy

E168 Practices for General Techniques of Infrared Quantitative Analysis

IEEE/ASTM SI-10 Standard for Use of the International System of Units (SI):The Modern Metric System

¹ This practice is under the jurisdiction of ASTM Committee D20 on Plastics and is the direct responsibility of Subcommittee D20.70 on Analytical Methods.

Current edition approved Dec. 1, 2011. Published December 2011. Originally published as D5477 – 93. Last previous edition approved in 2002 as D5477 – 02, which was withdrawn in January 2011 and reinstated in December 2011. DOI: 10.1520/D5477-11.

² For referenced ASTM standards, visit the ASTM website, www.astm.org, or contact ASTM Customer Service at service@astm.org. For *Annual Book of ASTM Standards* volume information, refer to the standard's Document Summary page on the ASTM website.

3. Terminology

3.1 *Definitions:*

3.1.1 For definitions of some of the terms used in this practice, refer to Terminologies D883 and D1600.

3.1.2 For units, symbols, and abbreviations used in this practice, refer to Terminology E131 or IEEE/ASTM SI-10.

4. Significance and Use

4.1 A speck will ultimately cause a failure to occur by virtue of its appearance in a film or by the decrease in electrical or mechanical properties in the polymer substrate (see Specification D1248).

4.2 The analysis of composite layers for barrier purposes by microscopic Fourier transform infrared spectroscopy (FT-IR) can indicate the adequacy of the barrier tape or indicate why a barrier may be defective (a missing layer or hole in the layer or poor coextrusion practice). Fig. 1 represents a typical multi-layer film.

5. Apparatus

5.1 *FT-IR Spectrophotometer*, with nominal 4-cm⁻¹ resolution (see Practices E168).

5.2 *Microsampling Accessory*, accommodated into the FT-IR for microscopic infrared and visible light analysis, with nominal 6.25- μ m resolution on the infrared mode.³

5.3 *Optical Microscope*, equipped with cross-polarized light and phase contrast accessories.

5.4 *Hot-Stage*, which is accommodated into the optical microscope.

5.5 *Microtome*.

5.6 *SurlynTM Ionomer*, 1.25-mm thick.⁴

5.7 *Cyano-Acrylate Adhesive*.

5.8 *Micrometer*, capable of measuring to ± 0.0025 mm (0.0001 in., 0.1 mil).

6. Material

6.1 *Cyano-Acrylate Adhesive*.

³ Perkin Elmer Spectrum Spotlight 300 IR Imaging System.

⁴ Metal salt of carboxylated polyethylene.

*A Summary of Changes section appears at the end of this standard

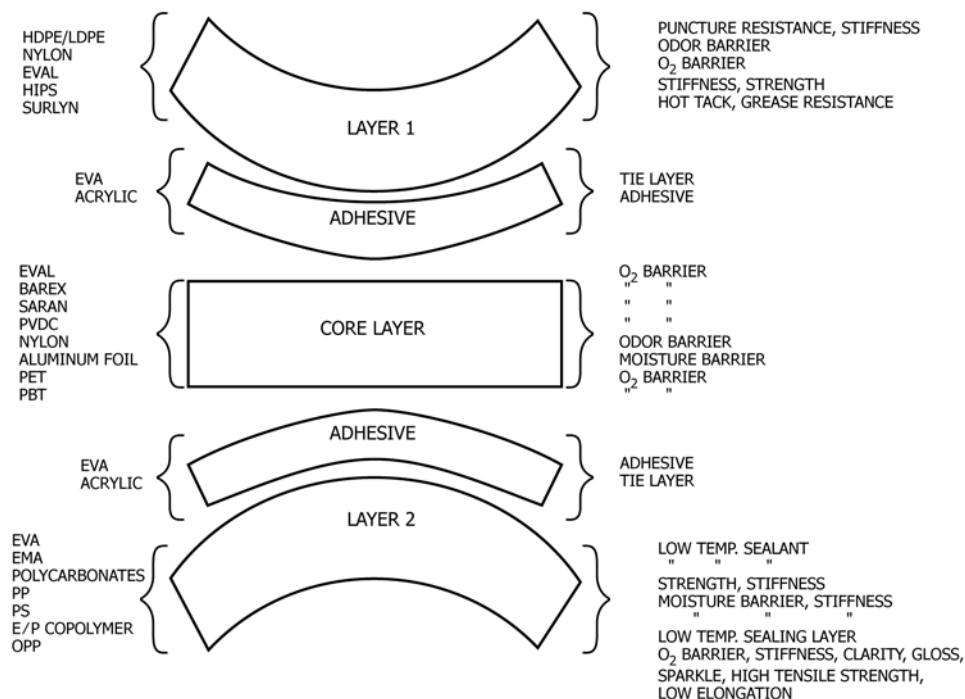

FIG. 1 Position and Function of Materials in Typical Multilayer Films

7. Hazards

7.1 Use gloves when plaques are prepared using a heated press. Take care to avoid burns when handling microscopic slides with the hot plate.

7.2 The optical bench of the FT-IR spectrophotometer contains a laser. To avoid eye injury, do not stare directly into the laser beam.

7.3 The cyano-acrylate adhesive will attach itself to the fingers and skin. Be careful to prevent this from occurring.

8. Specimen Preparation

8.1 It is necessary to microtome a thin cross section at right angles to the surface of the film in order to prepare the individual layers for convenient observation.

8.2 Packages that do not deflect during sectioning can be microtomed into the required thin sections as received. Flexible packages must be supported during sectioning. The support technique that is used for flexible packages is shown in Fig. 2. In this sandwich, a Surlyn™ ionomer is used for the support and a cyano-acrylate adhesive is used to bond the flexible package material to the Surlyn™.

8.3 The entire sandwich is then microtomed into suitable sections.

9. Procedure

9.1 Optical Microscopy:

9.1.1 In essentially all cases, the most obvious first step is to observe the sample visually in an optical microscope. The

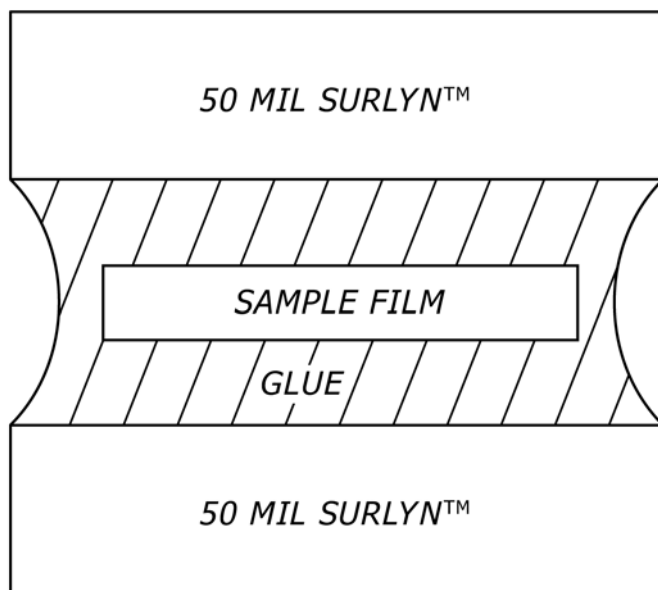

FIG. 2 Sandwich for Thin Films

fundamentals of optical microscopy and sample preparation have been discussed in detail elsewhere.⁵

9.1.2 The key to optical microscopy analysis is sample preparation. A 25 to 50-mm thick section with very few knife marks is required. Knife marks are a gouge created in the section by a defect in the microtome knife. Under crosspolarized light, knife marks will confuse and distort the boundaries of inhomogeneities or layer boundaries in multilayer specimens.

⁵ Chamot, E. M., and Mason, C. W., *Handbook of Chemical Microscopy*, John Wiley and Sons, Inc., New York, NY, 1985.

9.1.3 Once suitable, thin, sections have been collected, they are viewed in the optical microscope under cross-polarized light. In pigmented materials, it is also necessary to view the materials in uncrossed polarized light. Differences in contrast between inhomogeneities of layers develop in these situations due to differences in the intrinsic birefringence of the resins, thermal and stress history, and pigment concentration. The differences in contrast generally define material boundaries. The areas of interest may then be photographed and measurements made to quantify the dimensions of inhomogeneities or layers.

9.1.4 Since differences in contrast may arise from factors other than material differences, it is necessary to conduct a hot-stage microscopic analysis. In the hot stage, each of the different materials is located in accordance with differences in their melting temperature where their birefringence disappears in the microscope under cross-polarized light. The test is conducted at a heating rate of 10°C/min. It is advisable to recrystallize the polymers and recheck the melting points.

9.1.5 The infrared microscope permits the identification and analysis of inclusions and multilayer films down to diameters of 10 μm.

9.1.6 This procedure uses the microscope to locate and view small areas of a specimen. This microscope mounts into a FT-IR spectrometer. Infrared spectra may then be obtained for each area of interest.

9.1.7 A Nicolet 6000 FT-IR spectrometer was used. All spectra were recorded at 4-cm⁻¹ resolution. Acceptable signal-to-noise ratios (S/N) were obtained by the co-adding of 100 spectra at a mirror velocity of 0.586 cm/s. A Spectra-Tech IR-Plan III transmittance-reflectance microscope was used to focus the infrared radiation through the sample.

9.1.8 A schematic diagram of an instrument capable of performing these tasks is shown in Fig. 3. This microscope accessory is very useful for locating and then identifying small inhomogeneities, such as a particle or oxidized zone in a plastic film. Its use is unique for the identification of the layers in a multilayer film or sheet. The area of interest is identified by the interpretation of the infrared spectra obtained for that area.

10. Report

10.1 Report the following information:

10.1.1 Identify the material,

10.1.2 Indicate which method was used in preparing the sample,

10.1.3 Report the results, and

10.1.4 Report the date of the test.

11. Keywords

11.1 Fourier transform infrared spectroscopy (FT-IR); infrared microscopy; infrared spectroscopy; microsampling; visible light polarizer

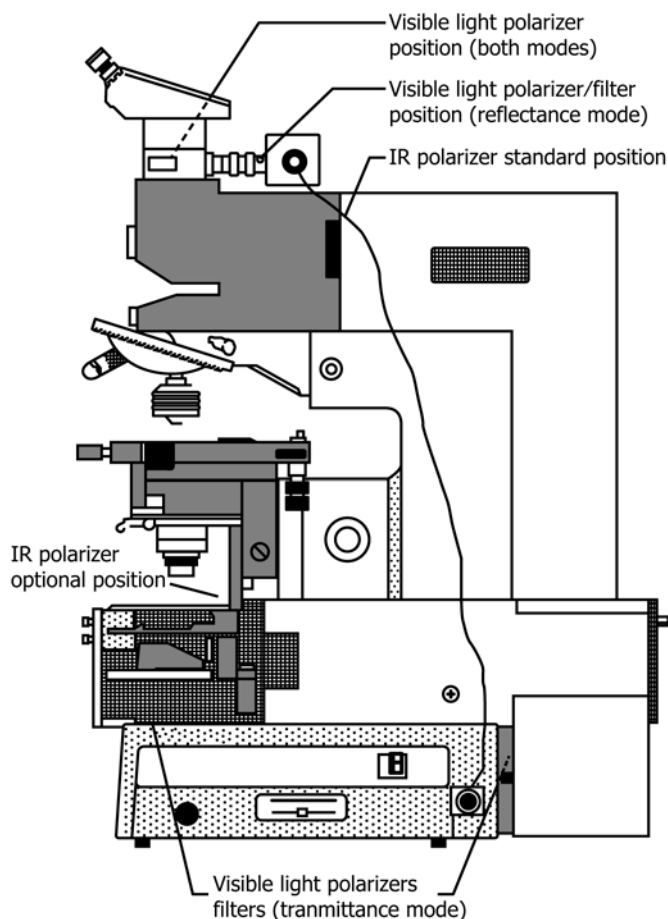

FIG. 3 Schematic Diagram of Infrared Microsampling Accessory

ASTM International takes no position respecting the validity of any patent rights asserted in connection with any item mentioned in this standard. Users of this standard are expressly advised that determination of the validity of any such patent rights, and the risk of infringement of such rights, are entirely their own responsibility.

This standard is subject to revision at any time by the responsible technical committee and must be reviewed every five years and if not revised, either reapproved or withdrawn. Your comments are invited either for revision of this standard or for additional standards and should be addressed to ASTM International Headquarters. Your comments will receive careful consideration at a meeting of the responsible technical committee, which you may attend. If you feel that your comments have not received a fair hearing you should make your views known to the ASTM Committee on Standards, at the address shown below.

This standard is copyrighted by ASTM International, 100 Barr Harbor Drive, PO Box C700, West Conshohocken, PA 19428-2959, United States. Individual reprints (single or multiple copies) of this standard may be obtained by contacting ASTM at the above address or at 610-832-9585 (phone), 610-832-9555 (fax), or service@astm.org (e-mail); or through the ASTM website (www.astm.org). Permission rights to photocopy the standard may also be secured from the Copyright Clearance Center, 222 Rosewood Drive, Danvers, MA 01923, Tel: (978) 646-2600; <http://www.copyright.com/>