



Standard Test Method for Smoke Obscuration of Insulating Materials Contained in Electrical or Optical Fiber Cables When Burning in a Vertical Cable Tray Configuration¹

This standard is issued under the fixed designation D5424; the number immediately following the designation indicates the year of original adoption or, in the case of revision, the year of last revision. A number in parentheses indicates the year of last reapproval. A superscript epsilon (ϵ) indicates an editorial change since the last revision or reapproval.

1. Scope*

1.1 This is a fire-test-response standard.

1.2 This test method provides a means to measure the smoke obscuration resulting from burning electrical insulating materials contained in electrical or optical fiber cables when the cable specimens, excluding accessories, are subjected to a specified flaming ignition source and burn freely under well ventilated conditions.

1.3 This test method provides two different protocols for exposing the materials, when made into cable specimens, to an ignition source (approximately 20 kW), for a 20 min test duration. Use it to determine the flame propagation and smoke release characteristics of the materials contained in single and multiconductor electrical or optical fiber cables designed for use in cable trays.

1.4 This test method does not provide information on the fire performance of electrical or optical fiber cables in fire conditions other than the ones specifically used in this test method, nor does it measure the contribution of the cables to a developing fire condition.

1.5 Data describing the burning behavior from ignition to the end of the test are obtained.

1.6 The production of light obscuring smoke is measured.

1.7 The burning behavior is documented visually, by photographic or video recordings, or both.

1.8 The test equipment is suitable for making other, optional, measurements, including the rate of heat release of the burning specimen, by an oxygen consumption technique and weight loss.

1.9 Another set of optional measurements are the concentrations of certain toxic gas species in the combustion gases.

1.10 The values stated in SI units are to be regarded as standard. No other units of measurement are included in this standard. (See [IEEE/ASTM SI 10](#).)

1.11 *This standard measures and describes the response of materials, products, or assemblies to heat and flame under controlled conditions, but does not by itself incorporate all factors required for fire hazard or fire risk assessment of the materials, products or assemblies under actual fire conditions.*

1.12 *Fire testing is inherently hazardous. Adequate safeguards for personnel and property shall be employed in conducting these tests.*

1.13 *This standard does not purport to address all of the safety concerns, if any, associated with its use. It is the responsibility of the user of this standard to establish appropriate safety and health practices and determine the applicability of regulatory limitations prior to use.*

2. Referenced Documents

2.1 ASTM Standards:²

- [D1711 Terminology Relating to Electrical Insulation](#)
 - [E84 Test Method for Surface Burning Characteristics of Building Materials](#)
 - [E176 Terminology of Fire Standards](#)
 - [E800 Guide for Measurement of Gases Present or Generated During Fires](#)
 - [E1354 Test Method for Heat and Visible Smoke Release Rates for Materials and Products Using an Oxygen Consumption Calorimeter](#)
 - [IEEE/ASTM SI 10 Standard for Use of the International System of Units \(SI\): The Modern Metric System](#)
- ### 2.2 NFPA Standards:³
- [NFPA 70 National Electrical Code](#)
 - [NFPA 289 Standard Method of Fire Test for Individual Fuel Packages](#)

¹ This test method is under the jurisdiction of ASTM Committee D09 on Electrical and Electronic Insulating Materials and is the direct responsibility of Subcommittee D09.21 on Fire Performance Standards.

Current edition approved Nov. 1, 2014. Published November 2014. Originally approved in 1993. Last previous edition approved in 2010 as D5424 – 10. DOI: 10.1520/D5424-14.

² For referenced ASTM standards, visit the ASTM website, www.astm.org, or contact ASTM Customer Service at service@astm.org. For *Annual Book of ASTM Standards* volume information, refer to the standard's Document Summary page on the ASTM website.

³ Available from National Fire Protection Association (NFPA), 1 Batterymarch Park, Quincy, MA 02169-7471, <http://www.nfpa.org>.

*A Summary of Changes section appears at the end of this standard

2.3 Underwriters Laboratories Standards:⁴

UL 1581 Reference Standard for Electrical Wires, Cables, and Flexible Cords

UL 1685 Standard Vertical Tray Fire Propagation and Smoke Release Test for Electrical and Optical Fiber Cables

2.4 Canadian Standards Association Standards:⁵

CSA Standard FT-4 Vertical Flame Tests: Cables in Cable Trays, Section 4.11.4 in C22.2 No. 0.3, Test Methods for Electrical Wires and Cables

2.5 IEEE Standards:⁶

IEEE 1202 Standard for Flame Testing of Cables for Use in Cable Tray in Industrial and Commercial Occupancies

2.6 Other Standards:

CA Technical Bulletin 133 Flammability Test Procedure for Seating Furniture for Use in Public Occupancies, January, 1991⁷

Nordtest Method NT Fire 032 Upholstered Furniture: Burning Behavior—Full Scale Test⁸

ISO 13943 Fire Safety—Vocabulary⁹

3. Terminology

3.1 *Definitions*—For definitions of terms used in this test method and associated with fire issues, refer to Terminology **E176** and ISO 13943. In case of conflict, the definitions given in Terminology **E176** shall prevail. For definitions of terms used in this test method and associated with electrical insulation issues, refer to Terminology **D1711**.

3.2 Definitions of Terms Specific to This Standard:

3.2.1 *sample, n*—an amount of the cable type and construction to be tested, which is representative of the product for test.

3.2.2 *specimen, n*—the individual length of cable, or cable bundle, to be placed in the cable tray, which is representative of the product to be tested.

4. Summary of Test Method

4.1 This fire-test-response standard determines a number of fire-test-response characteristics associated with smoke obscuration resulting from burning the materials insulating full-scale specimens of electrical or optical fiber cables located in a vertical cable tray and ignited with a propane gas burner. This test method is also suitable for making other, optional measurements, including rates of heat release, total amounts of heat released, rates and concentrations of carbon oxides released, and rates and amounts of mass of the specimen lost (see **Appendix X2**). Further optional measurements are also possible.

⁴ Available from Underwriters Laboratories (UL), 333 Pfingsten Rd., Northbrook, IL 60062-2096, <http://www.ul.com>.

⁵ Available from Canadian Standards Association (CSA), 5060 Spectrum Way, Mississauga, ON L4W 5N6, Canada, <http://www.csa.ca>.

⁶ Available from Institute of Electrical and Electronics Engineers, Inc. (IEEE), 445 Hoes Ln., P.O. Box 1331, Piscataway, NJ 08854-1331, <http://www.ieee.org>.

⁷ Available from Bureau of Home Furnishings and Thermal Insulation, State of California, Department of Consumer Affairs, 3485 Orange Grove Ave., North Highlands, CA 95660-5595.

⁸ Available from Nordtest, P.O. Box 22, SF-00341, Helsingfore, Finland, 1987.

⁹ Available from International Organization for Standardization (ISO), 1, ch. de la Voie-Creuse, Case postale 56, CH-1211, Geneva 20, Switzerland, <http://www.iso.ch>.

4.2 The vertical cable tray that holds the specimen is located in an enclosure of specified dimensions.

4.3 A hood, connected to a duct, is located above the fire enclosure. Smoke release instrumentation is placed in the duct. Heat and gas analysis release instrumentation (optional) is also placed in the duct.

4.4 Two different test procedures are specified, which differ in the burner used and in the electrical or optical fiber cable loading. These reflect details of three existing test methods: UL 1581 (protocol A) and CSA Standard FT-4 in C22.2 No. 0.3-M1985, or IEEE 1202 (protocol B) and UL 1685 (both protocols).

5. Significance and Use

5.1 This test method provides a means to measure a variety of fire-test-response characteristics associated with smoke obscuration and resulting from burning the electrical insulating materials contained in electrical or optical fiber cables. The specimens are allowed to burn freely under well ventilated conditions after ignition by means of a propane gas burner.

5.2 Smoke obscuration quantifies the visibility in fires.

5.3 This test method is also suitable for measuring the rate of heat release as an optional measurement. The rate of heat release often serves as an indication of the intensity of the fire generated.

5.4 Other optional fire-test-response characteristics that are measurable by this test method are useful to make decisions on fire safety. The most important gaseous components of smoke are the carbon oxides, present in all fires. They are major indicators of the toxicity of the atmosphere and of the completeness of combustion, and are often used as part of fire hazard assessment calculations and to improve the accuracy of heat release measurements. Other toxic gases, which are specific to certain materials, are less crucial for determining combustion completeness.

5.5 Test Limitations:

5.5.1 The fire-test-response characteristics measured in this test method are a representation of the manner in which the specimens tested behave under certain specific conditions. Do not assume they are representative of a generic fire performance of the materials tested when made into cables of the construction under consideration.

5.5.2 In particular, it is unlikely that this test method is an adequate representation of the fire behavior of cables in confined spaces, without abundant circulation of air.

5.5.3 This is an intermediate-scale test, and the predictability of its results to large scale fires has not been determined. Some information exists to suggest that it has been validated against some large-scale scenarios.

6. Apparatus

6.1 Enclosure:

6.1.1 The enclosure in which the specimen is tested is shown in **Fig. 1**.

6.1.2 The enclosure has a floor area of $2.44 \text{ m} \pm 25 \text{ mm}$ by $2.44 \text{ m} \pm 25 \text{ mm}$, with a height of $3.35 \text{ m} \pm 25 \text{ mm}$ ($8 \text{ ft} \pm$

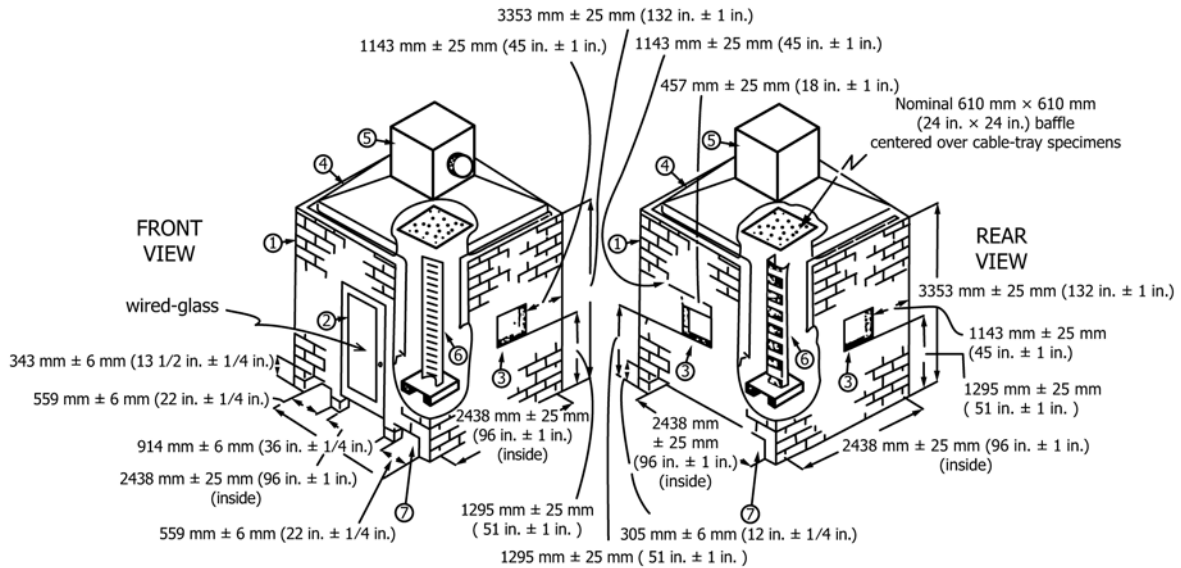

1. Enclosure: an acceptable construction consists of concrete masonry blocks, laid up with mortar, nominally 203 mm high by 406 mm wide by 152 mm thick (8 by 16 by 6 in.).
2. Wired-glass door, for access and observation. The overall size of the door is 2.1 m high and 0.9 m wide (84 by 36 in.).
3. Steel-framed wired-glass observation windows, 457 mm (18 in.) per side (optional).
4. Truncated-pyramid stainless steel hood, with each side sloped 40°.
5. Cubical collection box, 914 mm (36 in.) per side, with exhaust duct centered on one side.
6. Cable tray, mounted vertically in the center of the enclosure. Tray base (stand) is optional.
7. Air intake openings.

FIG. 1 Cable Test Enclosure

1 in. by 8 ft ± 1 in. by 11 ft ± 1 in. high). On top of the walls there is a pyramidal collection hood with a collection box.

6.1.2.1 Other enclosure sizes, such as 2.4 by 2.4 by 2.4 m (8 by 8 by 8 ft) or the 3 m cube are permitted, provided that the internal volume of the enclosure, exclusive of the pyramidal hood, ranges between 14.5 and 36 m³ (512 and 1272 ft³), the floor area ranges between 6 and 9 m² (97 and 64 ft²), and the maximum air movement within the enclosure complies with 6.1.10 (Note 1).

NOTE 1—There is, as yet, not enough information as to the equivalence on smoke release between the various facilities. Further work needs to be done to confirm this.

6.1.2.2 In case of disputes, the referee method are the tests conducted using the enclosure in 6.1.2.

6.1.3 Walls—The maximum conductive heat flux loss of the walls of the structure is 6.8 W/(m²K) (30 Btu/h-ft²), based upon an inside wall temperature of 38°C (100°F) and an outside air temperature of 24°C (75°F). Paint the interior surface of the walls flat black. Any materials of construction that meet the preceding requirements are acceptable. Two examples of acceptable construction materials are nominally 152 mm (6 in.) thick concrete masonry blocks (density: 1700 kg/m⁻³ (106 lb/ft⁻³) and thermal conductivity nominally $k = 1.75$ W/(m K), at 21°C; 12.13 Btu in./ft² h °F, at 70°F), or nominally 13 mm (0.5 in.) gypsum board, with 89 ± 6 mm (3.5 ± 0.25 in.) of standard fiberglass insulation, with an R value of 1.94 m² K/W (which corresponds in practical units to an R value of 11 h ft²°F/Btu). Windows for observation of the fire

test are allowed in the walls; ensure that the total area of the windows does not exceed 1.86 m² (20 ft²).

6.1.3.1 Select materials of construction which can withstand the high temperatures and presence of open flame within the test enclosure and duct.

6.1.4 Provide air intakes at the base of two opposite walls, one of which contains the access door. Ensure that the total cross sectional area of the air intakes is 1.45 ± 0.03 m⁴ (2250 ± 50 in.²), and that the intake areas are divided approximately equally. Fig. 1 shows dimensions for the air intakes installed in the walls. Air intakes are not permitted in either of the other two walls.

6.1.5 Construct a door with wired glass and locate it as shown in Fig. 1. The door is 900 ± 25 mm wide and 2100 ± 25 mm high (35 ± 1 in. by 83 ± 1 in.), with an overall conductive heat flux loss no greater than that of the walls, that is, 6.8 W/(m²K) (30 Btu/h-ft²). A steel framed wired glass door will meet these requirements. Adequately seal the sides and the top of the door to prevent drafts.

6.1.6 Construct a truncated pyramid stainless steel hood, formed as shown in Fig. 1, and locate it on top of the enclosure walls. Make the slope on each side of the hood 40°. Form a seal between the hood and the walls; a compressible inorganic batting as gasket is suitable.

6.1.7 Insulate the exterior of the hood to make an overall conductive heat loss no greater than that of the walls.

6.1.8 Locate a cubical stainless steel collection box (914 ± 25 mm (36 ± 1 in.) per side) on top of the exhaust hood, with

a nominal 406 ± 25 mm (16 ± 1 in.) diameter stainless steel pipe exhaust duct centered in one side.

6.1.9 Install the exhaust duct horizontally and connect it to the plenum of the hood.

6.1.10 Ensure that the maximum air movement within the enclosure, with only the intake and exhaust openings open, the exhaust fan on, and the burner off, does not exceed 1 m/s (3.3 ft/s), as measured by a vane-type anemometer in the following areas: (1) at the floor level where the burner is positioned during the test, and (2) at 1.50 ± 0.05 m (4.9 ft \pm 2 in.) above the enclosure floor, where the cable tray is positioned during the test.

6.1.11 Construct a square 610 ± 25 -mm (24 ± 1 -in.) baffle, centered over the cable tray. An acceptable height is 300 to 400 mm (12 to 15 in.) above the tray.

6.1.12 Construct a collection-exhaust system consisting of a blower, steel hood, duct, bidirectional probe, thermocouple(s), oxygen measurement system (optional), smoke obscuration measurement system, and gas analysis system (optional). Ensure that the system for collecting the combustion products has the capacity and is designed in such a way that all of the combustion products leaving the burning specimen are collected. Make the exhaust system capacity at least 2.7 m³s⁻¹ at normal pressure and at a temperature of 25 ± 2 °C. Construct the collection-exhaust system as explained in [Annex A2](#) and [Annex A3](#).

6.2 Exhaust Collection System:

6.2.1 Construct the exhaust collection system with the following minimal requirements: a blower, steel hood, duct, bidirectional probe, thermocouple(s), and a smoke obscuration measurement system (white light photocell lamp/detector or laser). Construct the exhaust collection system as explained in [Annex A2](#) and [Annex A3](#).

6.2.2 Ensure that the system for collecting the combustion products has sufficient exhaust capacity and is designed in such a way that all of the combustion products leaving the burning specimen are collected. Design the capacity of the evacuation system such that it will exhaust minimally all combustion gases leaving the cable specimen (see [Annex A2](#), [A2.1.4](#)).

6.2.3 Place probes for sampling of combustion gas and for measurement of volume flow rate in the exhaust duct leading from the hood.

6.3 Instrumentation in the Exhaust Duct:

6.3.1 The following specifications are minimum requirements for exhaust duct instrumentation. Additional information is found in [Annex A3](#).

6.3.2 *Flow Rate Measurement*—Measure the flow rate in the exhaust duct by means of a bidirectional probe, or an equivalent measuring system, with an accuracy of at least ± 6 % (see [Annex A3](#) for further details). The response time to a stepwise change of the duct flow rate shall not exceed 5 s to reach 90 % of the final value.

6.3.3 Use a bidirectional probe or an equivalent measuring system to measure pressure in the duct. Locate the probe shown in [Fig. 2](#) in the exhaust duct, at least 4.6 m (15 ft) but no more than 13.7 m (45 ft) from the centerline of the collection box. Ensure that the minimum length between any bend and the probe is at least eight times the inside diameter of

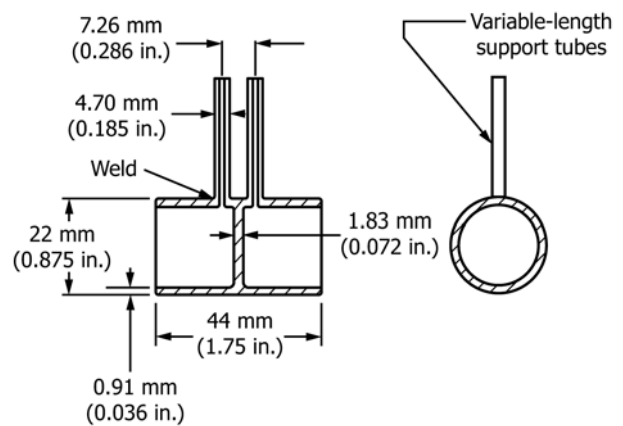

FIG. 2 Bidirectional Probe

the duct. If the system is positioned at a different location, demonstrate the achievement of equivalent results.

6.3.4 Build the probe of a short stainless steel cylinder 44-mm (1.75-in.) long and 22-mm (0.875-in.) inside diameter with a solid diaphragm in the center. The pressure taps on either side of the diaphragm are also the support for the probe. Position the axis of the probe along the centerline of the duct. Connect the taps to a pressure transducer able to resolve pressure differences of 0.25 Pa (0.001 in. of water).

6.3.5 Measure gas temperatures in the vicinity of the probe with Inconel sheathed Chromel-Alumel thermocouples. Ensure that the thermocouple does not disturb the flow pattern around the bidirectional probe. Further details are discussed in [A3.1](#).

6.4 Smoke Obscuration Measurements:

6.4.1 Install an optical system for measurement of light obscuration across the centerline of the exhaust duct. Determine the optical density of the smoke by measuring the light transmitted with a photometer system consisting of a white light source and a photocell/detector or a laser system for measurement of light obscuration across the centerline of the exhaust duct. Locate the system so that it is preceded by at least eight diameters of duct without bends, to ensure a nearly uniform velocity across the duct section. If the system is positioned at a different location, demonstrate the achievement of equivalent results.

6.4.2 One photometer system found suitable consists of a lamp, lenses, an aperture, and a photocell (see [Fig. 3](#) and [A3.2](#)). Construct the system so that soot deposits on the optics during a test do not reduce the light transmission by more than 5 %.

6.4.2.1 Alternatively, instrumentation constructed using a 0.5 to 2.0 mW helium-neon laser, instead of a white light system, is also acceptable. See [Fig. 4](#) and [A3.2](#) for further details. White light and laser systems give similar results ([1-4](#)).¹⁰

6.5 Cable Tray:

6.5.1 Use a steel ladder cable tray, 300 ± 25 mm (12 ± 1 in.) wide, 75 ± 6 mm (3 ± 0.25 in.) deep, and 2440 ± 25 mm

¹⁰ The boldface numbers in parentheses refer to the list of references at the end of this standard.

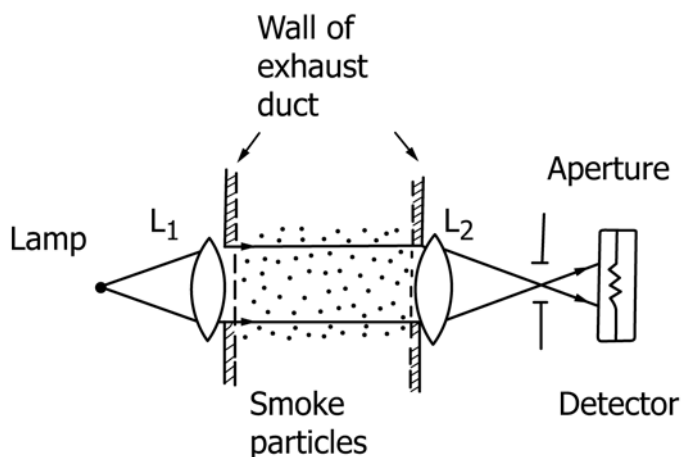

FIG. 3 Optical System

(8 ft ± 1 in.) long. Arrange the tray so that the burner flame will impinge on the cables midway between rungs.

6.5.1.1 Each rung in the tray is to measure 25 ± 6 mm (1 ± 0.25 in.) in the direction parallel to the length of the tray and 13 ± 3 mm (0.5 ± 0.125 in.) in the direction parallel to the depth of the tray.

6.5.1.2 Space the rungs 230 ± 13 mm (9 ± 0.5 in.) apart (measured center to center).

6.5.1.3 Attach the rungs to the side rails.

6.5.1.4 Mount the cable tray vertically in the center of the enclosure. Position the tray on a tray base (stand), which is to be no higher than 152 ± 25 mm (6 ± 1 in.).

6.5.2 Place a square galvanized steel platform under the cable tray. The platform shall be constructed of nominally 1.6 mm (1/16 in.) thick steel, and have dimensions of no less than 1.0 by 1.0 m (approximately 39 by 39 in.), with a uniform raised lip 100 mm (approximately 4 in.) high, on each side, to catch falling material. The platform shall be covered by a tight fitting sheet of standard gypsum board, of nominally 13 mm (0.5 in.) thickness. If a load cell is placed underneath the cable tray (as optionally in X2.1), the platform shall protect the load cell. The gypsum board shall be clean before the start of a test; if the sheet used has been damaged it shall be replaced.

NOTE 2—A square galvanized steel platform of dimensions of up to 1.22 by 1.22 m (approximately 4 by 4 ft), with a raised lip, is also acceptable.

6.6 Burner:

6.6.1 Use a 254-mm (10-in.) strip or ribbon-type propane gas burner with an air/gas Venturi mixer.

6.6.2 The flame-producing surface of the burner consists essentially of a flat metal plate that is 341 mm (13 7/16 in.) long and 30 mm (1 1/32 in.) wide. The plate has an array of 242 holes drilled in it. The holes are to be 1.35 mm (metric drill size: 1.35 mm) or 0.052 in. (No. 55 drill) in diameter, on 3.2-mm (0.125-in.) centers in three staggered rows of 81, 80 and 81

holes each, to form an array measuring 257 by 5 mm (10 1/8 by 3/16 in.). Center the array of holes on the plate (see Fig. 5).¹¹

6.6.3 Protocol A:

6.6.3.1 Position the burner behind the cable tray containing the specimen, with the flame-producing surface (face) of the burner vertical and its long dimension horizontal, and with the 257-mm (10 1/8-in.) dimension of the array of holes spaced 76 ± 5 mm (3.0 ± 0.2 in.) from the specimens in the tray and centered midway between the side rails of the tray. Position the centerpoint of the array of holes at 457 mm (18 in.) above the bottom end of the tray and specimen and midway between two rungs. Support the burner in a manner to enable the burner to be quickly removed and precisely returned to the position described. The burner faces the doorway.

6.6.4 Protocol B:

6.6.4.1 Mount the burner on a stand and place it 20 ± 2° from the horizontal with the burner ports up, in front of the cable tray. Locate the major axis of the burner ports 305 ± 25 mm (12 ± 1 in.) above the base of the cable tray and parallel to the cable tray rungs during the fire test (Fig. 6). The burner faces the doorway.

6.6.4.2 Attach a guide to the burner or stand such that the leading edge of the burner face is located quickly and accurately 76 ± 5 mm (3 ± 0.2 in.) horizontally away from the nearest surface of the cables during the burn period of the test.

6.6.5 Insert a flowmeter in both the propane and the air lines feeding the burner to measure the flow rates of these gases during the test.

6.6.6 Use a propane flowmeter capable of measuring at least 230 cm³/s (29 ft³/h) and an air flowmeter of at least 1330 cm³/s (170 ft³/h). Flow rate measurements shall be accurate to within 3 %. Mass flow controllers with recordable outputs are permitted alternatives.

6.6.7 Supply compressed air to the burner, either bottled or from a compressed air system. Filter the air supply sufficiently so as to eliminate any contaminants that might affect the test results.

6.6.8 Use air with a dew point no greater than 0°C (32°F), as measured by a dew point measuring device.

6.6.9 Use CP grade propane (99 % pure), having a heat content of approximately 50.8 MJ/kg (21.7 k Btu/lb) (93.0 MJ/m³ at 20°C, 101 kPa), for the burner.

6.6.10 Use a propane flow rate of 220 ± 8 cm³/s (28 ± 1 ft³/h) when corrected to standard temperature and pressure (20°C, 101 kPa). This propane flow will provide a theoretical heat output of 20 kW (approximately 70 000 Btu/h). The actual heat output is less, due to incomplete combustion of the propane at the burner.

¹¹ The sole source of supply of the apparatus known to the committee at this time is a burner supplied by American Gas Furnace Company, Inc., of Elizabeth, NJ, Catalog No. 10 L11-55, with an air/gas Venturi mixer, Catalog No. 14-18. If you are aware of alternative suppliers, please provide this information to ASTM International Headquarters. Your comments will receive careful consideration at a meeting of the responsible technical committee,¹ which you may attend.

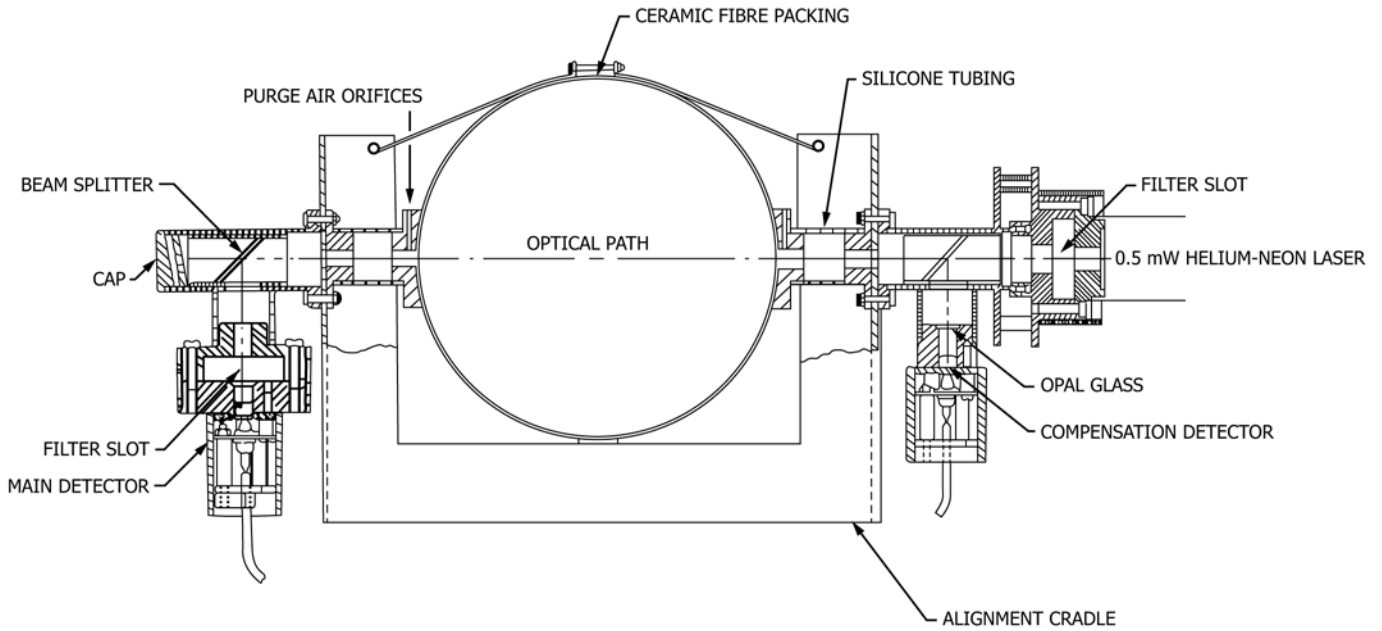

FIG. 4 Laser Extinction Beam

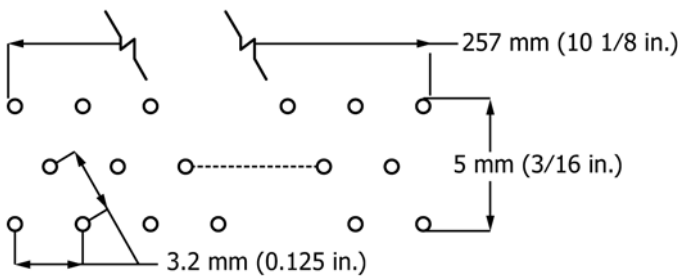

FIG. 5 Burner Holes

6.6.11 Use an air flow rate to the burner of $1280 \pm 80 \text{ cm}^3/\text{s}$ ($163 \pm 10 \text{ ft}^3/\text{h}$) when corrected to standard temperature and pressure.

6.7 Cable Mounting:

6.7.1 Protocol A—Fasten $2438 \pm 10\text{-mm}$ ($96 \pm 0.5\text{-in.}$) specimen lengths of finished cable in a single layer in the tray by means of steel or copper wire, not larger than 2.1 mm^2 (14 AWG gauge) in cross section, at their upper and lower ends and at two other equally spaced points along their lengths with each cable vertical. Install as many specimens in the tray as will fit, spaced $\frac{1}{2}$ cable diameter apart, to fill the center 150 mm (6 in.) of the tray width.

6.7.1.1 Determine the number of specimen lengths for test using Eq 1:

$$N = [(4 \times 25.4)/D] + 0.33 \quad (1)$$

where:

N = number of cables (rounded up to the nearest whole number), and

D = diameter of the cable, mm.

6.7.2 Protocol B—Fasten $2438 \pm 10 \text{ mm}$ ($96 \pm 0.5 \text{ in.}$) specimen lengths of finished cable in the tray. Depending upon the outside diameter of the individual cables, the test specimen is to be either an individual length or a bundle of individual

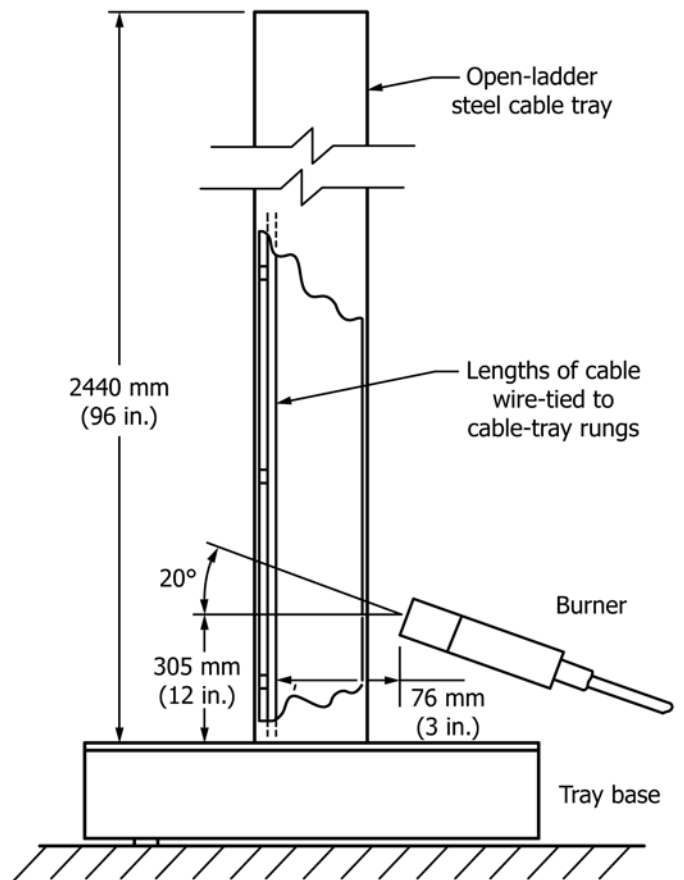

FIG. 6 Protocol B Cable Tray

lengths. Center the specimens or specimen bundles in a single layer between the side rails of the cable tray. Ensure that the lower end of each specimen is no more than 100 mm (4 in.) above the bottom end of the cable tray. Attach each individual

TABLE 1 Tray Loading for Circular Cables Smaller than 13 mm (0.5 in.) in Diameter

Cable Diameter, mm		Number of Cables in Each Bundle	Number of Bundles in Tray
From	But Less Than		
11	13	3	7
9	11	3	8
6	9	3	10
5	6	7	9
3	5	19	8
0	3	19	13

specimen or bundle of specimens separately to each rung of the cable tray using one wrap of a copper or steel wire tie not larger than 2.1 mm² (14 AWG) in diameter.

6.7.2.1 For cables smaller in diameter than 13 mm (0.5 in.), group the specimens into untwisted bundles (nominally circular) as shown in **Table 1**. Space the bundles ½ bundle diameter apart on the cable tray as measured at the point of attachment to the cable tray.

6.7.2.2 For cables 13 mm (0.5 in.) in diameter and larger, attach the individual specimens to the cable tray with spacings of ½ cable diameter, except do not exceed a spacing of 15 mm (0.6 in.). **Table 2** shows the tray loading.

6.7.3 On flat cables, calculate the equivalent cable diameter using **Eq 2**:

$$D = 1.128 \times \sqrt{(T \times W)} \quad (2)$$

where:

- D = calculated equivalent cable diameter,
- T = minor axis of the cable, and
- W = major axis of the cable.

7. Test Specimens

7.1 Use multiple lengths of electrical or optical fiber cable as test specimens.

7.2 The mounting of the specimen on the cable tray is specified in **6.7**.

8. Calibration

8.1 Prior to the start of each day of testing, verify the linearity of the photometer system by interrupting the light beam with multiple calibrated neutral density filters to cover the range of the recording instrument. Use at least two neutral density filters of significantly different values, and also one for 100 % transmission. Ensure that the transmittance values measured by the photometer, using neutral density filters, are within ±3 % of the specified value for each filter.

8.2 At the end of each test, investigate and correct any excessive departure from the zero line.

8.3 Perform a calibration of the flow rates of propane and air from the burner before each continuous test series.

8.4 The recommended procedure for calibration of the propane gas flow rate is by measuring the heat release rate in the duct using **Eq 3**. Further details are given in **X2.3**.

$$\dot{q} - E \times 1.10 \times C \sqrt{\left[\frac{\Delta p}{T_e} \right]} \times \left[\frac{(X_{O_2}^A - X_{O_2}^A)}{1.084 - 1.5 \times X_{O_2}^A} \right] \quad (3)$$

TABLE 2 Tray Loading for Cables 13 mm (0.5 in.) in Diameter and Larger

Cable Diameter, mm		Number of Cables in Tray
From	But Less Than	
13	15	11
15	19	9
19	21	8
21	26	7
26	28	6
28	39	5
39	52	4
52	73	3
73	120	2

where:

- \dot{q} = rate of heat release, kW,
- C = orifice plate coefficient, in kg^½ m^½ K^½,
- Δp = pressure drop across the orifice plate or bidirectional probe,
- T_e = gas temperature at the orifice plate, K,
- E = net heat released for complete combustion, per unit of oxygen consumed, 13 100 kJ/kg O₂,
- $X_{O_2}^A$ = measured mole fraction of O₂ in incoming air, nondimensional, and
- $X_{O_2}^A$ = measured mole fraction of O₂ in exhaust flow, nondimensional.

9. Conditioning

9.1 Prior to testing, condition the specimen for at least 3 h in an atmosphere at a temperature of 23 ± 5°C (73°F) with a relative humidity of less than 55 %. Test cables within 10 min of removal from such conditions if test room conditions differ from the preceding conditions.

10. Procedure

10.1 Do not carry out the test if the wall temperature of the chamber is below 5°C (41°F) or above 30°C (86°F).

10.2 Establish an initial volumetric flow rate of 0.65 ± 0.05 m³/s (23 ± 2 ft³/s) through the duct. Calculate the volumetric flow rate of the gas in the duct from **Eq A1.1** in **Annex A1** and reported as a function of time, starting 1 min prior to the test. Do not change the flow rate once the initial flow rate is established.

10.3 Position the prepared cable tray vertically inside the enclosure with the open front of the cable tray facing the front of the enclosure. Fix the cable tray firmly in position.

10.4 Start all recording and measuring devices before starting the ignition burner, to ensure they are stabilized.

10.5 Ignite the gas mixture in the burner and adjust the gas flows to the values specified in **6.6.10** and **6.6.11**. Position the burner as indicated in **6.6.3** (Protocol A) or **6.6.4** (Protocol B). See **Fig. 6** for the relative positions of the cable tray and burner in the enclosure.

10.6 Allow the burner flame to impinge on the specimen for a continuous period of 20 min.

10.7 At 20 min, extinguish the burner flame, but allow the cable fire (if any) to burn out.

10.8 Photograph or video record the cable tray and flame before and during the test. Include a clock, giving the time to the nearest 1 s, in all photographic records.

10.9 During the test, record the following events and the time when they occur:

- 10.9.1 Ignition of the specimen,
- 10.9.2 Position of flame front,
- 10.9.3 Melting and dripping,
- 10.9.4 Occurrence of pool fire under the specimen,
- 10.9.5 General description of the burning behavior,
- 10.9.6 Time of afterburn, after extinguishing the propane, and
- 10.9.7 Any other event of special interest.

NOTE 3—It is possible for ignition of the cables to occur almost immediately after ignition of the burner. However, time to ignition of the cables may be difficult to determine.

10.10 Conduct the procedure in duplicate on the number of sets of specimens specified. Conduct each procedure (burn) on untested cable specimens.

10.11 *Evaluation of Damage:*

10.11.1 After burning has ceased, and after the cables and tray have cooled to room temperature, wipe the cables clean with a cloth, and determine cable damage.

10.11.1.1 *Protocol A*—Determine the maximum height of charred cable damage by measuring the blistering, char, and other damage upward from the bottom of the vertical tray.

10.11.1.2 *Protocol B*—Determine the maximum height of charred cable damage by measuring the blistering, char, and other damage upward from the lower edge of the burner face.

10.11.2 Determine the limit of charring by pressing against the cable surface with a sharp object. Where the surface of the cable (outer jacket, if any) changes from a resilient surface to a brittle (crumbling) surface determines the limit of charring. Include distortion of the outer surface of the cable, such as blistering or melting, immediately above the char, in the damage measurement.

10.11.3 Record the cable damage (char) to the nearest 25 mm (1 in.). On cable constructions that do not have charring, define the limit for the affected portion as the point where the overall diameter is visibly reduced or increased.

10.11.4 For engineering information, record damage such as blistering, or softening/melting of combustible material above the char.

10.12 *Smoke Obscuration Measurements:*

10.12.1 Make continuous measurements of light obscuration by the smoke and volume flow rate in the exhaust duct.

10.12.2 From these measurements, and the equations in [Annex A4](#), determine the rates and amounts of light obscuring smoke. These values together with the visual recordings constitute the results from the test.

11. Calculation

11.1 Equations for smoke release calculations are presented in [Annex A4](#). Considerations for heat release measurements (optional) are presented in [Appendix X4](#), and the appropriate equations for calculations are in [Appendix X5](#). The choice of

the equations in [Appendix X5](#) that the testing laboratory wishes to use for the (optional) heat release calculations is up to the testing laboratory.

12. Report

12.1 Report the following information:

12.1.1 *Descriptive Information:*

- 12.1.1.1 Name and address of the testing laboratory,
- 12.1.1.2 Inside dimensions of the enclosure,
- 12.1.1.3 Date and identification number of the report,
- 12.1.1.4 Name and address of the test requester,
- 12.1.1.5 Methods of sampling,
- 12.1.1.6 Name of product manufacturer or supplier, if known,
- 12.1.1.7 Name or other identification marks and description of the product,
- 12.1.1.8 Density, or weight per unit surface, and total mass, thickness of the main components in the product, and mass of combustible portion of product, if known,
- 12.1.1.9 Description of the samples,
- 12.1.1.10 Conditioning of the specimens,
- 12.1.1.11 Date of test, and
- 12.1.1.12 Test number, Protocol (A or B), and any special remarks.

12.1.2 *Test Results* (see also Appendixes).

12.1.3 *Table of Mandatory Numerical Results Containing:*

- 12.1.3.1 Maximum char damage, m,
- 12.1.3.2 Peak rate of smoke release, m^2s^{-1} , and the appropriate time that it occurred,
- 12.1.3.3 Total smoke released, m^2 , and
- 12.1.3.4 Time of afterburn, s.

12.1.4 *Additional Table of Mandatory Numerical Results, Containing:*

- 12.1.4.1 Total smoke release data after every minute, and
- 12.1.4.2 Rate of smoke release data after every minute.

12.1.5 *Mandatory Graphical Results:*

- 12.1.5.1 Plot of rate of smoke release versus time, and
- 12.1.5.2 Plot of total smoke released versus time.

12.2 *Descriptive Results:*

- 12.2.1 Photographs or videotape, if available, of the fire development, and
- 12.2.2 All available information listed in [10.9](#).

13. Precision and Bias

13.1 *Precision*—The precision of this test method has not been determined. Results of a planned interlaboratory test series will be included when available.

13.2 *Bias*—The true value of fire performance of electrical or optical fiber cables can only be defined in terms of a test method. Within this limitation, this test method has no known bias and can be accepted as a reference method.

14. Keywords

14.1 cable; cable tray; carbon dioxide; carbon monoxide; char; electrical cable; fire; fire-test response; flame; heat release; heat release rate; ignition; optical density; optical fiber

cable; oxygen consumption calorimetry; smoke obscuration; smoke release; smoke release rate; total smoke released; toxic gases

ANNEXES

(Mandatory Information)

A1. CALCULATION OF VOLUMETRIC FLOW RATE

A1.1 The volumetric flow rate in m^3/s in the duct under standard conditions is calculated according to Eq A1.1, as follows:

$$V_s = C_V k_t A \sqrt{\left[\frac{2\Delta_p T_o}{\rho_o T} \right]} = 20.1 kA \sqrt{\left[\frac{\Delta_p}{T} \right]} \quad (\text{A1.1})$$

where:

C_V = a suitable calibration factor for bidirectional probes based upon air velocities in excess of 3.0 m/s (10 ft/s) in a 0.4-m (16-in.) duct, nondimensional,

k_t = ratio of the average duct gas mass flow per unit area, as determined by measuring the velocity and temperature profiles across the stack, to the duct mass gas flow rate per unit area, as determined by measuring the velocity and temperature at the centerline where the bidirectional probe is located during the test,

A = cross-sectional area of the duct at the location of the probe, m^2 ,

Δ_p = differential pressure measured with the probe, Pa,

ρ_o = density of air, kg/m^3 , at the reference temperature T_o , K,

T = duct gas temperature, K, and

T_o = the reference temperature, K.

A2. DESIGN OF EXHAUST SYSTEM

A2.1 Hood and Exhaust Duct, Recommended Design:

A2.1.1 Collect the combustion gases from the burning specimen by means of a hood. A system is described in A2.1.2 which was tested in practice and proven to fulfill the specifications given in the test method.

A2.1.2 The hood is located above the room. The bottom dimensions of the hood are 2.44 by 2.44 m (8 by 8 ft) (see Fig. 1). The hood feeds into a cubical box/plenum having 914 ± 13 mm (36.0 ± 0.5 in.) as the dimension of each side. A maximum height of $1.8 \text{ m} \pm 0.05 \text{ m}$ (5 ft 11 in. ± 2 in.), to satisfy building constraints, is acceptable. Underneath the hood, two baffle plates approximately 0.61 by 0.61 m (2 by 2 ft) are located (see Fig. 1), to increase mixing of the combustion gases. Design and manufacture the hood so that no leakage exists.

A2.1.3 If a laser beam is used, a suitable means of mounting the beam together with the gas sampling probes is shown in Fig. A2.1.

A2.1.4 An exhaust duct is connected with the plenum chamber. The inner diameter of the exhaust duct is 406 ± 25 mm (16 ± 1 in.). To facilitate flow measurements, guide vanes,

if needed, are located at both ends of the exhaust duct. Alternatively, the rectilinear part of the exhaust duct must have such a length that a fully-developed flow profile is established at the point of measurement. The exhaust duct is connected to an evacuation system.

A2.1.5 Design the capacity of the evacuation system so as to exhaust minimally all combustion gases leaving the specimen. This requires an exhaust capacity of at least 2.7 kg s^{-1} (about $8000 \text{ m}^3 \text{ h}^{-1}$ at standard atmospheric conditions) corresponding to a driving under pressure of about 2 kPa at the end of the duct. Provide a means to control the exhaust flow from about 0.5 kg s^{-1} up to maximum flow as stated above during the test process. Ensure that the measurement system has sufficient sensitivity for measurement of low rates of heat release. Mixing vanes in the duct are a means of solving the problem if concentration gradients are found to exist.

A2.1.6 An alternative exhaust system design is acceptable if it is shown to produce equivalent results. Equivalency is demonstrated by meeting the calibration requirements of Section 8. Exhaust system designs based on natural convection are unacceptable.

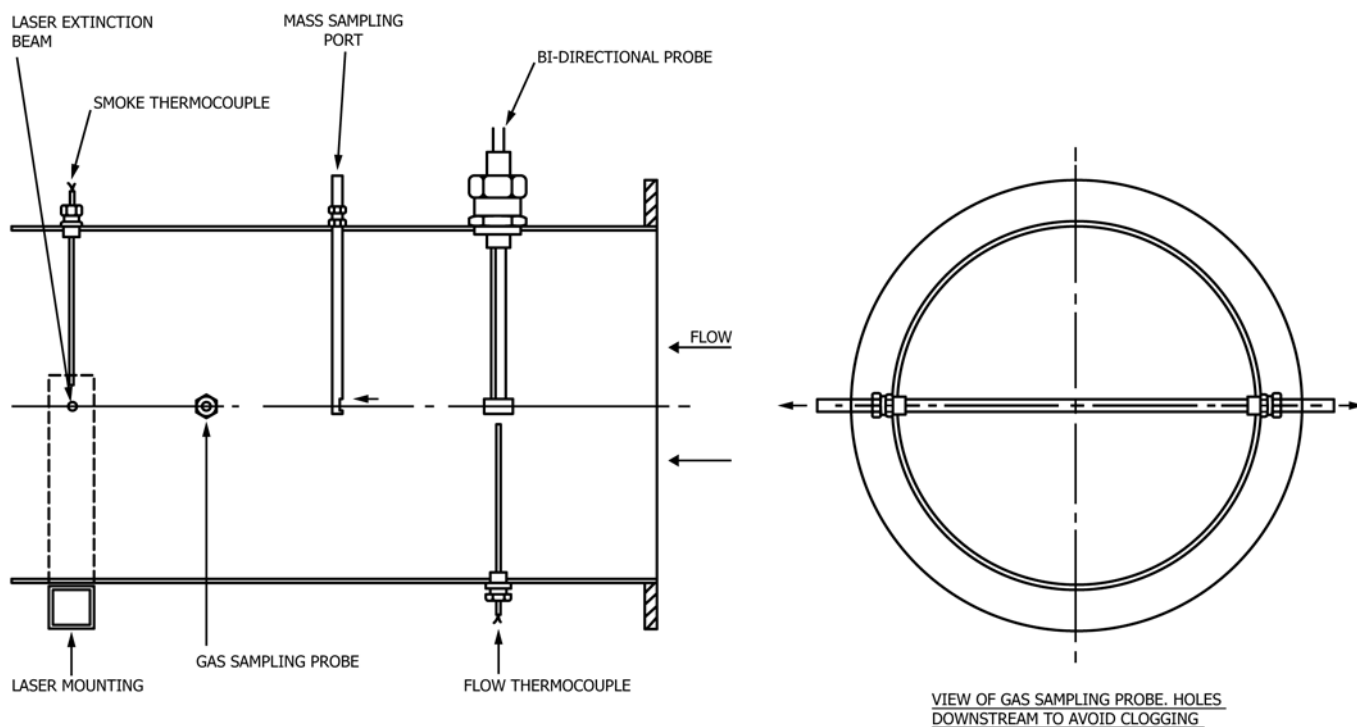

FIG. A2.1 Means of Mounting Laser Beam and Sampling Probe

A3. INSTRUMENTATION IN EXHAUST DUCT

A3.1 Volume Flow:

A3.1.1 One technique for measuring the flow is a bidirectional probe located at the centerline of the duct. The probe shown in Fig. 2 consists of a stainless steel cylinder, 44 mm (1.75 in.) long and with an inner diameter of 22 mm (0.875 in.). The cylinder has a solid diaphragm in the center, dividing it into two chambers. The pressure difference between the two chambers is measured by a differential pressure transducer.

A3.1.2 Use a differential pressure transducer with an accuracy of at least ± 0.25 Pa (0.001 in.) of water and of the capacitance type. A suitable range of measurement is 0 to 150 Pa.

A3.1.3 Place one thermocouple 152 ± 25 mm (6 ± 1 in.) upstream from the bidirectional probe. Use an Inconel sheathed 24 AWG gauge (0.51 mm (0.020 in.) in diameter) thermocouple, type K Chromel-Alumel. Place the thermocouple wire, within 13 mm (0.5 in.) of the bead, along expected isotherms to minimize conduction errors. Use an insulation between the Chromel and Alumel wires that is stable to at least 1100°C (2000°F). Ensure that the thermocouple does not disturb the flow pattern around the bidirectional probe.

A3.2 Smoke Obscuration:

A3.2.1 One suitable light measuring system based on white light has the following components: a lamp, plano convex lenses, an aperture, a photocell, and an appropriate power

supply. Mount lenses, lamp, and photocell inside two housings located on the exhaust duct, diametrically opposite each other. It has been found that a system consisting solely of a white light and a photocell, along the exhaust duct, across from each other and at an angle to the vertical, is satisfactory in some cases.

A3.2.1.1 Use a lamp of the incandescent filament type, which operates at a color temperature of $2900 \pm 100^\circ\text{K}$. Supply the lamp with stabilized direct current, stable within $\pm 0.2\%$ (including temperature, short term and long term stability). Center the resultant light beam on the photocell.

A3.2.1.2 Select the lens system such that the lens L_2 , according to Fig. 3, has a diameter, d , chosen with regard to the focal length, f , of L_2 so that $df \leq 0.04$.

A3.2.1.3 Place the aperture in the focus of lens L_2 according to Fig. 3.

A3.2.1.4 Use a detector with a spectrally distributed response according to the CIE photopic curve and linear within 5% over an output range of at least 3.5 decades. Check this linearity over the entire range of the instrument periodically with calibrated optical filters.

A3.2.2 The system described as follows is an example of a light measuring system that has been found satisfactory:

- (1) Lenses—Plano convex: diameter 40 mm, focal length 50 mm,
- (2) Lamp—Osram Halo Stars: 64410: 6 V, 10 W, or equivalent,

(3) *Photocell*—United Detector Technology: PIN 10 AP, or equivalent, and

(4) *Voltage Supply*—Gresham Lion Ltd: Model G × 012, or equivalent.

A3.2.2.1 Design a system that is easily purged against soot deposits. The use of holes in the periphery of the two housings is a means of achieving this objective.

A3.2.3 An acceptable alternate system for measurements of smoke obscuration uses a laser beam. A0.5 to 2.0 mW helium-neon laser beam is projected across the exhaust duct. Couple the two halves of the device rigidly together (see Fig. 4).

A4. SMOKE MEASUREMENT EQUATIONS

A4.1 *Mass Flow Rate Measurements:*

NOTE A4.1—Symbols are explained in A4.3.

A4.1.1 There are primarily two techniques used to measure mass flow rate in the exhaust duct of full-scale fire tests.

A4.1.2 The first technique measures mass flow rate by means of the pressure drop across, and temperature at, an orifice plate. If the test is conducted within a narrow range of conditions, the orifice plate coefficient, C , is approximately constant. It is possible to determine its value with a gas burner calibration. However, if flow rates are varied during a test or if temperature changes are considerable, take into account the effect on C of the Reynolds number and of pressure at the downstream side of the orifice plate. Information on such corrections and on various design options (for example, location of the pressure taps) is found in Ref. (5).

A4.1.3 The other technique is to measure velocity at one point in the duct, usually along the centerline. Calculate the flow rate using a measured velocity profile in the duct. This velocity profile is obtained by measuring velocity at a sufficient number of representative points over the diameter or cross section of the duct prior to any fire tests. Detailed procedures to obtain this profile are described in Ref. (6). Usually, conditions in full scale fire tests are such that the flow in the duct is turbulent, resulting in a shape factor k_c (ratio of the average velocity to the velocity along the centerline) close to 1.

A4.1.4 Due to considerable soot production in many fires, pitot tubes are generally not useful because of clogging of the holes. This is unlikely to cause a problem in a test of a single item. Thus, if pitot tubes are used, they must be completely cleaned after each test. In order to deal with this problem, a more robust bidirectional probe was designed by McCaffrey and Heskestad (7). This involves measuring the differential pressure across the probe and the centerline velocity, and is valid in the range of Reynolds numbers, Re :

$$40 < Re < 3800 \quad (\text{A4.1})$$

In many full scale fire test applications, duct diameter and flow rate are such that the Reynolds number is:

$$Re > 3800 \quad (\text{A4.2})$$

In this case $f(Re)$ can be taken as a constant (1.08), which greatly simplifies the calculations.

A4.1.5 *Mass Flow Rate Measurement Equations:*

A4.1.5.1 *Pressure Drop Method (Eq A4.3):*

$$\dot{m}_e = C \times \sqrt{\left[\frac{\Delta p}{T_e} \right]} \quad (\text{A4.3})$$

A4.1.5.2 *Velocity Method (Eq A4.4):*

$$\dot{m}_e = 26.54 \times \frac{A \times k_c}{f(Re)} \times \sqrt{\left[\frac{\Delta p}{T_e} \right]} \quad (\text{A4.4})$$

A4.1.6 The function of the Reynolds number $f(Re)$ is described, by McCaffrey and Heskestad (7), as responding to Eq A4.5:

$$f(Re) = 1.533 - 1.366 \times 10^{-3} Re \quad (\text{A4.5})$$

$$+ 1.688 \times 10^{-6} Re^2 - 9.705 \times 10^{-11} Re^3$$

$$+ 2.555 \times 10^{-13} Re^4 - 2.484 \times 10^{-17} Re^5$$

A4.2 *Smoke Measurement Equations:*

Optical density (OD) (Eq A4.6):

$$OD = \log[I_0/I] \quad (\text{A4.6})$$

Extinction coefficient (k) (Eq A4.7):

$$k = (1/L_p) \times \ln(I_0/I) \quad (\text{A4.7})$$

The volumetric flow rate is calculated as the product of the mass flow rate and the density of air, at the corresponding temperature. Thus, both the volumetric flow and the density of air must undergo temperature corrections. The volumetric duct flow rate (\dot{V}) is adjusted because it is measured in the exhaust duct, but required at the temperature near the photodetector, as shown in Eq A4.8:

$$\dot{V}_s = \dot{V}_e \times \left(\frac{T_s}{T_e} \right) \quad (\text{A4.8})$$

The density of air is adjusted between the literature value, measured at 273.15 K, and the value at the temperature in the exhaust duct, as shown in Eq A4.9:

$$\rho = \rho_o \times \frac{273.15}{T_e} \quad (\text{A4.9})$$

Then, the final equation (Eq A4.10) for the volumetric flow rate:

$$\dot{V}_s = \frac{\dot{m}_e}{\rho_o} \times \frac{T_e}{273.15} \quad (\text{A4.10})$$

Rate of smoke release (RSR) is defined by Eq A4.11:

$$RSR = [\dot{V}_s \times k] \quad (\text{A4.11})$$

Total smoke released (TSR) is defined by Eq A4.12:

$$TSR = \int RSR dt \quad (\text{A4.12})$$

Average optical density (*Av OD*) (Eq A4.13):

$$Av OD = \sum OD_{scan\ i} / \sum scans \quad (A4.13)$$

A4.2.1 Measurement of Smoke Obscuration Parameters:

A4.2.1.1 The optical density of smoke is dependent upon the volumetric flow rate in the duct, and is, thus, not an absolute measurement. It is recommended that smoke release rate and its integrated value (total smoke released) are more adequate measurement values.

A4.2.1.2 In at least one document, UL 1685, rate of smoke release is defined in terms of optical density instead of being defined in terms of the more usual extinction coefficient. The difference between the two resulting values of rate of smoke release is a constant factor: the natural logarithm of 10, that is, 2.3026, with the numbers based on optical density being lower.

A4.3 Symbols:

<i>A</i>	= cross sectional area of duct, m ² ,
<i>Av OD</i>	= average optical density,
<i>C</i>	= orifice plate coefficient, kg ^{1/2} m ^{1/2} K ^{1/2} ,
<i>f(Re)</i>	= Reynolds number correction,
<i>I</i>	= light intensity for a parallel light beam having traversed a certain length of smoky environment and reaching photodetector,
<i>I₀</i>	= light intensity for a beam of parallel light rays, measured in a smoke free environment, with a detector having the same spectral sensitivity as the human eye and reaching the photodetector,

<i>k</i>	= extinction coefficient, 1/m,
<i>k_c</i>	= velocity profile shape factor, nondimensional,
<i>L_p</i>	= light path length of beam through smoky environment, m,
<i>m_e</i>	= $C (\Delta_p/T_e)^{1/2}$, mass flow rate, by pressure drop measurement, kg/s,
<i>m_e</i>	= $(26.54 \times A \times k_c / f(Re)) \times (\alpha / T_e)^{1/2}$, mass flow rate, by velocity measurement, kg/s,
<i>OD</i>	= optical density, nondimensional,
Δp	= pressure drop across the orifice plate or bidirectional probe, Pa,
<i>RSR</i>	= rate of smoke release, m ² /s,
<i>T_e</i>	= gas temperature at the orifice plate, K,
<i>T_s</i>	= duct temperature (near photodetector), K,
<i>TSR</i>	= total smoke released, m ² ,
<i>V_e</i>	= volumetric flow rate in exhaust duct (at measuring location of mass flow rate), m ³ /s,
<i>V_s</i>	= volumetric flow rate at location of smoke meter (value adjusted for smoke measurement calculations), m ³ /s,
ρ	= density of air at the temperature in exhaust duct, kg/m ³ ,
ρ_o	= density of air at 273.15 K: 1.293, kg/m ³ ,
$\sum OD_{scan\ i}$	= summation of the optical density values measured at each scan, along the 20 min test period, and
$\sum scans$	= total number of scans, along the 20 min test period.

APPENDIXES

(Nonmandatory Information)

X1. COMMENTARY

X1.1 Introduction

X1.1.1 This commentary is provided to give some insight into the development of the test method and to describe a rationale for various features used, both in the mandatory and the optional sections of this standard.

X1.2 Measurements

X1.2.1 Smoke Obscuration:

X1.2.1.1 The visibility in a fire atmosphere will adversely affect the ability of victims to escape and the ability of fire brigades to fight the fire.

X1.2.2 Rate of Heat Release:

X1.2.2.1 The rate of heat release is one of the most important variables, possibly even the single most important variable, in determining the hazard from a fire (8-12). In particular, the rate of heat release is a measure of the intensity of the fire. The rate of heat release and the amount of heat released will determine the extent to which other materials, products or assemblies in the fire compartment may ignite and spread the fire further. The amount of smoke generated is usually a direct function of the heat release rate.

X1.2.2.2 It has now been determined that the rate of heat release can be determined by measuring the oxygen depletion in a fire atmosphere (13-15). Oxygen concentration measurement devices, of the paramagnetic type, are now sufficiently precise to measure the small differences in oxygen concentration needed for determining rate of heat release. Appendix X2 – Appendix X5 contain details on instrumentation, measurements and results to report for these optional fire-test-response characteristics.

X1.2.3 Smoke Toxicity:

X1.2.3.1 The victims of a fire are often overcome by the toxicity of the atmosphere. This is determined by the concentration of smoke (see Terminology E176) and by the toxicity of its individual components. The overall amount of smoke generated can be measured by means of the mass loss rate, which is equivalent to the rate of smoke generation. The single most important individual toxicant in a fire atmosphere is carbon monoxide, which is present in all fires, together with carbon dioxide and water (16, 17). Some other gases, such as acrolein, hydrogen cyanide, and hydrogen chloride, are also frequently present and may thus also contribute to the toxicity

of the fire atmosphere. **Appendix X2 – Appendix X5** contain details on instrumentation, measurements and results to be reported for these optional fire-test-response characteristics.

X1.3 Electrical Cables

X1.3.1 Traditional fire tests on electrical cables, such as those in the standards described as the basis of this test procedure, have focused on flame spread. This fire-test-response standard goes beyond that by additionally measuring smoke release.

X1.3.2 The determination of cable damage by measurement of maximum char length is not a totally adequate way of determining cable flame spread properties, but it gives a simple indication of quality of fire performance of the cable.

X1.3.3 The National Electrical Code has adopted a category of cables with a limited smoke (or -LS) designation, which are being listed after being tested for flame propagation and smoke release according to UL 1685.

X1.3.4 Optional measurements that are possible with this test method are the rates and amounts of heat release, and of carbon oxide release. These measurements allow a more complete set of fire-test-response characteristics to be obtained from a single specimen with the same fire model, which is then useful in assessing the fire hazard.

X1.4 Test Facility

X1.4.1 The rate of heat release of upholstered furniture in the standard ASTM room (2.44 by 3.66 by 2.44 m high, or 8 by 12 by 8 ft high), in the room described in California Technical

Bulletin 133 (10 by 12 by 8 ft high, or 3.05 by 3.66 by 2.44 m high) and in a furniture calorimeter (such as those described in NFPA 289 or Nordtest NT Fire 032), are equivalent, unless the heat release rate exceeds 600 kW (18). This suggests that, if heat or smoke release rate is the only information sought, the size of the test facility may not be critical. However, further work is required to confirm these results for cable tests.

X1.4.2 It has also been shown that very similar results are obtained from two different test facilities, in both heat and smoke release, for many electrical cables (1-3). This is an important result, because it suggests, too, that the exact dimensions and layout of the facility are not as crucial as was at one point thought. This also needs further confirmation.

X1.4.3 It has been shown that the smoke release measured with a laser beam and with a white light system are equivalent, unless the scanning time is very long (>5 s). This applies to both small scale instruments (19, 4) and full scale cable tray testing facilities (1-3).

X1.4.4 The platform described in 6.5.2 is needed to ensure all laboratories use the same means of protecting the load cell, and help to improve precision of results. It has been shown that some materials that have been placed underneath the burning sample in large scale fire tests can cause significant differences in the extent to which fire, flames, and smoke continue being released by the material that has fallen off the burning sample. In at least one known case the heat and smoke release varied by over half the amount as a function of the material used beneath the sample.

X2. OPTIONAL MEASUREMENTS FOR WHICH THIS STANDARD IS SUITABLE

X2.1 Mass Loss Measurements

X2.1.1 If mass loss is to be measured, use a mass measuring device, such as a load cell, to continuously measure the mass loss of the burning specimen.

X2.1.2 The mass measuring device needs to measure the specimen mass with an accuracy of at least ± 45 g (1.6 oz) up to at least 90 kg (198 lb) of specimen mass. Install it in such a way that the heat from the burning specimen and any eccentricity of the load does not affect the accuracy. Avoid range shifts during measurements. Protect all parts of the weight measuring device by a thermal barrier.

X2.1.3 There are two alternative locations for the mass measuring device:

X2.1.4 *Alternative 1*—Place the mass measuring device under a platform, with a thermal barrier of dimensions 0.3 ± 0.05 by 0.3 ± 0.05 m (1 ft \pm 2 in. by 1 ft \pm 2 in.) and of a non-combustible material, for example, calcium silicate boards. Provide the platform with sides of $0.1 \text{ m} \pm 10 \text{ mm}$ (4 \pm 0.4 in.) height in order to prevent melting or falling material from the tested specimens from falling off the thermal barrier.

X2.1.5 Do not exceed 0.5 m (20 in.) from the upper surface of the thermal barrier to floor level. Shield the area between the

thermal barrier and the floor level to avoid lifting forces due to fire induced air flow that could influence the measurement. Ensure that there are virtually no obstructions to the air supply for the test set-up.

X2.1.6 *Alternative 2*—Place the mass measuring device in the hood and hang the cable tray from it. Thermal and combustion gas protection of the mass measuring equipment is still required.

X2.2 Heat Release and Gas Analysis Measurements

X2.2.1 Exhaust Collection System:

X2.2.1.1 For measurement of heat release and other gas analysis, the requirements of 6.2 and 6.3 are insufficient. Beyond the requirements of 6.2 and 6.3, the exhaust collection system needs an oxygen measurement system and a combustion gas sampling and analysis system. Construct these as explained in X2.2.2, and as shown in Figs. 1 and A2.1.

X2.2.2 Combustion Gas Analysis:

X2.2.2.1 *Sampling Line*—If combustion gases are measured, take the gas samples in the exhaust duct at a position where the combustion products are uniformly mixed. Construct the sampling line tubes of a material not influencing the concentration of the gas species to be analyzed. A logical

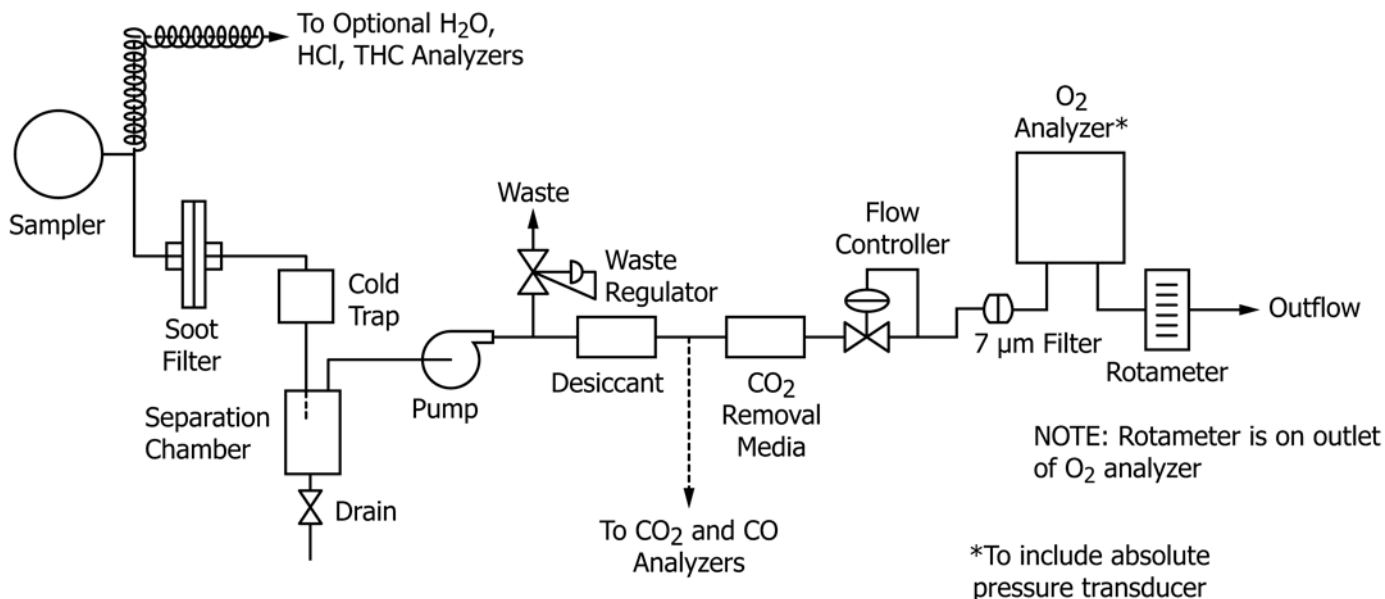

FIG. X2.1 Schematic Diagram of Gas Analysis System

sequence for the gas train is: sampling probe, soot filter, cold trap, plastic drying column and carbon dioxide removal columns (if used), gas path pump, vent valve, flow controller, and oxygen analyzer (see Fig. X2.1 and Annex A3). The gas train shall also include appropriate spanning and zeroing facilities.

X2.2.2.2 Oxygen Analyzer—If heat release is measured, measure the oxygen concentration with an accuracy of at least $\pm 0.2\%$ of full scale in the output range of 0 to 21 vol % oxygen, or ± 0.05 vol % oxygen, in order to have adequate measurements of rate of heat release. Take the gas sample from the end of the sampling line. Calculate the time delay, including the time constant of the instrument, from the room of origin. It is a function of the exhaust duct flow rate; a value of over 30 s is unacceptable. A discussion of the calculations for rate of heat release is given in Appendix X4.

X2.2.2.3 Carbon Monoxide and Carbon Dioxide Analyzers—If measured, measure the combustion gas species concentration with an instrument having an accuracy of at least ± 0.1 vol % for carbon dioxide and ± 0.02 vol % for carbon monoxide. A suitable output range is 0 to 1 vol % for carbon monoxide and 0 to 10 vol % for carbon dioxide. Take the gas sample from the end of the sampling line. Calculate the time delay, including the time constant of the instrument, from the room of origin. It is a function of the exhaust duct flow rate. It shall be a maximum of 30 s.

X2.3 Calibration

X2.3.1 The calibrations described in Section 8 do not address measurements of mass, heat release, or combustion gas concentrations. The appropriate instruments also need to be carefully calibrated with standard sources.

X2.3.2 Calibrate all instruments carefully with standard sources after initial installation. Perform recalibration tests routinely on the entire system, for example using standard output burners.

X2.3.3 Perform calibration of the mass measuring device by loading the weighing platform with known masses corresponding to the measuring range of interest, to ensure that the requirements of accuracy in X2.1.2 are fulfilled. Carry out this calibration daily, prior to testing.

X2.3.4 Calibrate gas analyzers daily, prior to testing (see Guide E800 for further details).

X2.3.5 Perform the calibration of the heat release instrumentation in the exhaust duct by burning propane gas and comparing the heat release rates calculated from the metered gas input, and those calculated from the measured oxygen consumption. The value of effective heat of combustion for propane is 46.5 MJ/kg. Position the burner in the same location as the cable tray is to be placed during the test. Measure the gas flow rate at a pressure of 101.3 ± 5 kPa (standard atmospheric pressure) and a temperature of $20 \pm 5^\circ\text{C}$.

X2.3.6 Obtain a minimum of two calibration points. Obtain a lower heat release rate value of 40 kW and then a higher heat release rate value of 160 kW. Approximate propane flow rates for any required heat release rate value are estimated using the following constant: 1.485 kW min/L. Accurate flow rates of propane gas are calculated using the mass flow rate equations.

X2.3.7 Take measurements starting 1 min prior to ignition of the burner and then at least once every 6 s thereafter to the end of the test. Determine the average rate of heat release over a 1 min period by (a) the oxygen consumption method, and (b) calculating the heat release rate from the mass gas flow rate and the effective heat of combustion. The two values must agree within 5%. Make this comparison only after steady state conditions are reached.

X2.3.8 Perform a calibration test in accordance with X2.3.5 – X2.3.7 prior to each continuous test series. Perform a full basic calibration on a new system or when modifications are introduced.

X2.3.9 The use of a higher rate of heat release for calibration, for example 500 kW, will lead to higher accuracy in test results.

X2.4 Test Procedure for Optional Measurements

X2.4.1 Use a continuous mass measuring device to determine the mass loss rate of the burning specimen.

X2.4.2 During the test, measure the concentrations of carbon monoxide, carbon dioxide, and oxygen in the exhaust duct.

X2.4.3 The concentrations of other combustion gases are optional measurements, but their usefulness depends on the chemical composition of the combustible portion of the specimen tested. In some cases it is also advantageous to measure the concentration of gases, such as hydrogen cyanide and nitrogen oxides, if the combustibles are known to contain nitrogen. In some other cases it is also advantageous to measure the concentration of gases such as hydrogen chloride, hydrogen bromide, or hydrogen fluoride if the combustibles are known or suspected to contain the corresponding halogen. Precision in calculating heat release is increased by measuring the concentration of water in the combustion gases. This increases the experimental difficulties, which is why it is not recommended.

X2.4.4 From these measurements, calculate the rates and amounts of release of heat, generation of gas species, and loss of specimen mass using the equations in [Appendix X4](#) and [Appendix X5](#). The testing laboratory is entitled to choose which of the equations in [Appendix X5](#) to use for the (optional) heat release calculations. Report these optional values (see

[X2.5](#)), together with the mandatory measurements from [Section 12](#) and the visual recordings as the results of the test.

X2.5 Report of Optional Test Measurements

X2.5.1 *Table of Optional Numerical Results:*

X2.5.1.1 Peak rate of heat release, kW, and the appropriate time at which it occurs,

X2.5.1.2 Total heat released, MJ,

X2.5.1.3 Peak flame height, m, and the appropriate time at which it occurs,

X2.5.1.4 Total mass loss, g,

X2.5.1.5 Total percentage of mass loss, %,

X2.5.1.6 Total percentage of combustible mass loss, %,

X2.5.1.7 Average yield of carbon monoxide, g CO/g fuel,

X2.5.1.8 Average yield of carbon dioxide, g CO₂/g fuel,

X2.5.1.9 Carbon monoxide/carbon dioxide molar yield ratio,

X2.5.1.10 Average yield of any other measured gas, g gas/g fuel, and

X2.5.1.11 Equation used to calculate rate of heat release.

X2.5.2 *Optional Graphical Results:*

X2.5.2.1 Plot of rate of heat release versus time,

X2.5.2.2 Plot of mass loss versus time,

X2.5.2.3 Plot of concentration of carbon monoxide versus time,

X2.5.2.4 Plot of concentration of carbon dioxide versus time,

X2.5.2.5 Plots of concentration of any other measured gas versus time, and

X2.5.2.6 Plot of mass flow rate in the exhaust duct versus time.

X3. ADDITIONAL INSTRUMENTATION IN EXHAUST DUCT

X3.1 The instrumentation described in [Annex A3](#) does not address the measurement of heat release or the determination of combustion gas concentrations. Appropriate instrumentation is described in the following sections:

X3.2 Sampling Line

X3.2.1 Locate the sampling probe in a position where the exhaust duct flow is well mixed. Use a probe with a cylindrical cross section to minimize disturbance of the air flow in the duct. Collect the gas samples along the whole diameter of the exhaust duct.

X3.2.2 Manufacture the sampling line (see [Fig. X2.1](#)), from corrosion resistant material, for example polytetrafluoroethylene. Remove the particulates contained in the combustion gases with inert filters to the degree required by the gas analysis equipment. Preferably, filter the gases in more than one step. Cool the gas mixture to a maximum of 10°C and dry the gas samples completely before they reach each analyzer.

X3.2.3 Use a pump for the combustion gases which does not allow the gases to contact oil, grease or similar products, all of which can contaminate the gas mixture. A membrane pump is suitable.

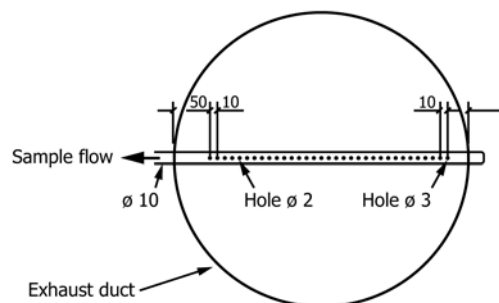

FIG. X3.1 Gas Sampling Probe

X3.2.4 A suitable sampling probe is shown in [Fig. X3.1](#). This sampling probe is of the bar type. Ring type sampling probes are also acceptable, although they do not collect gas samples across the full diameter of the duct. The sampling line is shown in [Fig. X2.1](#). A suitable pump has a capacity of 10 to 50 L min⁻¹ at 10 kPa (minimum), as each gas analysis instrument consumes about 1 L min⁻¹. A pressure differential of at least 10 kPa, as generated by the pump, reduces the risk of smoke clogging of the filters. Turn the intake of the sampling probe downstream to avoid soot clogging the probe.

X3.2.5 Install a soot filter, capable of removing all particles >25 microns in size.

X3.2.6 A refrigerated column is the most successful approach to cool and dry the gases. Provide a drain plug to remove the collected water from time to time. Alternative devices are also acceptable.

X3.2.7 If carbon dioxide is to be removed, it is important to use carbon dioxide removal media, as indicated in Fig. X2.1.

X3.3 Combustion Gas Analysis

X3.3.1 *Oxygen Concentration*—Use an oxygen analyzer, meeting the specifications of X2.2.2.2, preferably of the paramagnetic type.

X3.3.2 *Carbon Monoxide and Dioxide Concentration*—Analyzers found suitable are nondispersive infrared analyzers. See Guide E800 for further details.

X3.3.3 *Other Gases*—Guide E800 provides details of suitable analyzers to measure, for special purposes, the concentration of other gases, such as water, total hydrocarbon, nitrogen oxide, hydrogen cyanide, or hydrogen chloride.

X3.3.4 *Time Shift*—Gas concentration measurements require the use of appropriate time shifts in order to account for gas transit time within the sampling system.

X4. CONSIDERATIONS FOR HEAT RELEASE MEASUREMENTS

X4.1 Measurement of Rate of Heat Release by Oxygen Consumption

X4.1.1 *Introduction*—In 1917, Thornton (20) showed that for a large number of organic fuels, a more or less constant net amount of heat is released per unit of oxygen consumed for complete combustion. Huggett (21) obtained an average value for this constant of 13.1 MJ/kg of O₂. This value may be used for practical applications and is accurate, with very few exceptions, to within ±5 %.

X4.1.2 Thornton's rule implies that it is sufficient to measure the oxygen consumed in a combustion system in order to determine the net heat released. This is particularly useful for full-scale fire test applications. For example, for compartment fires, the oxygen consumption technique is much more accurate and easier to implement than methods based on measuring all the terms in a heat balance of the compartment.

X4.1.3 Perhaps the first application of the O₂ consumption principle in fire research was by Parker (22) using the Test Method E84 tunnel test. Later, Sensenig (23) applied it to an intermediate scale room test. During the late seventies and early eighties, the National Institute for Standards and Technology (NIST, formerly NBS) refined the O₂ consumption technique. A paper by Parker (24) gives equations to calculate rate of heat release by O₂ consumption for various applications. The technique is now used extensively in many laboratories all over the world, both in bench-scale (25) and full-scale (8, 26) fire test applications.

X4.1.4 The objective of this section is to provide a comprehensive set of equations and guidelines to determine the rate of heat release in full-scale fire tests based on the O₂ consumption principle. The approach followed here is somewhat different from Parker (25), as the emphasis is on full-scale fire test applications and it avoids the use of volumetric flow rates. Volumetric flow rates require specification of temperature and pressure. Various investigators have used different combinations of reference pressure and temperature. This leads to confusion which is greatly eliminated by the use of mass flow rates instead.

X4.1.5 The basic requirement is to collect and remove all combustion products in a hood and through an exhaust duct. At a distance downstream of the hood sufficient for adequate mixing, measure both flow rate and composition of the gases. It is assumed that it is not possible to measure the air flow rate into the system as this is generally the case for full-scale fire tests. The differences in treatment and equations used are mainly due to the extent to which gas analysis is made. Measure at least O₂, but, if additional instrumentation is available, heat release rate measurements are more accurate by measuring CO₂ and CO as well.

X4.1.6 It needs to be emphasized that the analysis is approximate. The following list describes the main simplifying assumptions made:

(1) The amount of energy released by complete combustion per unit of oxygen consumed is taken as: $E = 13.1$ MJ/kg of O₂.

(2) All gases are considered to behave as ideal gases. In other words, one mole of any gas is assumed to occupy a constant volume at the same pressure and temperature.

(3) Incoming air consists of O₂, CO₂, H₂O, and N₂. All "inert" gases, which do not take part in the combustion reactions, are lumped into the nitrogen.

(4) O₂, CO₂, and CO are measured on a dry basis. In other words, water vapor is removed from the sample before gas analysis measurements are made.

X4.1.7 In the analysis to follow, initial emphasis is placed on the flow rate measurement. Equations to calculate flow rate are generally applicable, irrespective of the configuration of the gas analysis system. In subsequent sections, distinction is made between various gas analyzer combinations.

X4.2 Rate of Heat Release Measurement if Only Oxygen is Measured

X4.2.1 In this case all water vapor and CO₂ are eliminated by the use of appropriate filtering media. This leads to the assumption that the sample gas only consists of O₂ and N₂. This is approximately true provided CO production is negligible. As the composition of the incoming air does not normally change during a test, and as the temperatures in

building fires are usually not high enough to generate noticeable amounts of nitrogen oxides by nitrogen fixation, the mole fraction of O_2 in the air as measured by the analyzer prior to a test can be written on the basis of O_2 and N_2 , exclusively. The mole fraction of O_2 in the exhaust gases, as measured by the oxygen analyzer, can be written likewise. As nitrogen is conserved and does not participate in the combustion reactions, the equations are derived on the basis of its conservation.

X4.2.2 In this case the rate of heat released (in kW) is calculated as a function of the heat released per unit of oxygen consumed (E , 13.1 MJ/kg of O_2), the ratio of the molecular weight of oxygen (M_1 , 32.0 kg/kmol) and the molecular weight of the incoming air (M_2 , generally taken as 28.97 kg/kmol), the mass flow rate of the incoming air (in kg/s), and the humidity of the incoming air. The flow rate measured is that of the smoke within the exhaust duct and not that of the incoming air. In order to find a relation between the two it is necessary to define the oxygen depletion factor. The oxygen depletion factor is the fraction of the incoming air which is fully depleted of its oxygen. It has been demonstrated (see Appendix in Test Method E1354), that the rate of heat release is a function of E , M_1 , M_2 , and the oxygen depletion factor, plus the expansion factor. The expansion factor has to be assigned and a recommended value is 1.084, the value for propane. The value for carbon in dry air is 1.0 and for hydrogen is 1.21.

X4.2.3 The resulting equation is expected to be accurate to within $\pm 5\%$ provided combustion is complete. In other words, all carbon is converted to CO_2 . Errors will be larger if CO or soot production is considerable or if a significant amount of the combustion products are other than CO_2 and H_2O . It is unlikely that these errors will be of concern for a single item of test.

X4.3 Rate of Heat Release Measurement if Oxygen and Carbon Dioxide are Being Measured

X4.3.1 This case is similar to that covered in the former section. We assume now that only water vapor is trapped before the sample reaches the gas analyzers. Again, the equations are derived on the basis of conservation of nitrogen. The mole fraction of CO_2 in the incoming air is taken to be 440 ppm. Again the equation for rate of heat release is accurate to within $\pm 5\%$, provided combustion is complete, in other words if all carbon converted to CO_2 .

X4.4 Rate of Heat Release Measurement if Oxygen, Carbon Dioxide and Carbon Monoxide are Being Measured

X4.4.1 This case reverts to that covered in X4.3 if CO production is negligible. Taking CO into account, however, changes the equations.

X4.5 Conclusions

X4.5.1 Depending on the configuration of gas analyzers and the type of flow rate measurement, use one of the following procedures to calculate rate of heat release:

X4.5.2 Case 1: Only O_2 is measured:

- (1) Calculate the mass flow rate of the exhaust gases,
- (2) Obtain the moisture content of the incoming air,
- (3) Calculate the oxygen depletion factor, and
- (4) Calculate the rate of heat release.

X4.5.3 Case 2: Both O_2 and CO_2 are measured:

- (1) Calculate the mass flow rate of the exhaust gases as in X4.5.2,
- (2) Obtain the moisture content of the incoming air as in X4.5.2,
- (3) Calculate the new oxygen depletion factor, and
- (4) Calculate the new rate of heat release.

X4.5.4 Case 3: O_2 , CO_2 , and CO are measured:

- (1) Calculate the mass flow rate of the exhaust gases as in X4.5.2,
- (2) Obtain the moisture content of the incoming air as in X4.5.2,
- (3) Calculate the new oxygen depletion factor, and
- (4) Calculate the new rate of heat release.

X4.5.5 Carbon dioxide is eliminated from the gas sample because it may interfere with the oxygen measurement. If a CO_2 analyzer is used, this eliminates the need for removal of CO_2 out of the gas sample. This is mainly of practical importance as the scrubbing agent used to remove CO_2 usually requires careful handling and is rather expensive. If significant amounts of CO are produced (for example at or beyond flashover in ventilation controlled room fires), accuracy of the rate of heat release measurement is greatly improved by measuring CO.

X4.5.6 The presence of a water vapor analyzer simplifies the analysis and improves accuracy even more. Unfortunately, implementation of a water vapor analyzer is not straightforward because heated sampling lines, filters, and so forth, are needed to avoid condensation. Thus, the use of a water vapor analyzer precludes the estimation of the expansion factor. However, for this standard, the use of water analyzers is not recommended.

X5. HEAT RELEASE MEASUREMENT EQUATIONS

X5.1 Rate of Heat Release

NOTE X5.1—Symbols are explained in X5.3.

X5.1.1 *Flow Rate*: Pressure drop measurement (Eq X5.1):

$$\dot{m}_e = C \times \sqrt{\left[\frac{\Delta p}{T_e}\right]} \quad (\text{X5.1})$$

Velocity measurement (Eq X5.2):

$$\dot{m}_e = 26.54 \times \frac{A \times k_c}{f(Re)} \times \sqrt{\left[\frac{\Delta p}{T_e}\right]} \quad (\text{X5.2})$$

X5.1.2 *Case 1*: Only O₂ is measured—Calculate the mass flow rate according to the Eqs in X5.1.1 (X5.1 – X5.2), and the oxygen depletion factor according to Eq X5.3:

$$\varphi = \frac{X_{O_2}^A - X_{O_2}^A}{[1 - X_{O_2}^A] \times X_{O_2}^A} \quad (\text{X5.3})$$

The rate of heat release is then calculated according to Eq X5.4:

$$\dot{q} = E \times \frac{M_{O_2}}{M_a} \times \frac{\varphi}{1 + \varphi \times (\alpha - 1)} \times \dot{m}_e \times X_{O_2}^A \quad (\text{X5.4})$$

If only O₂ is measured, Eq X5.4 simplifies to Eq X5.5:

$$\dot{q} = E \times 1.10 \times C \times \sqrt{\left[\frac{\Delta p}{T_e}\right]} \times \left[\frac{(X_{O_2}^A - X_{O_2}^A)}{1.105 - 1.5 \times X_{O_2}^A}\right] \quad (\text{X5.5})$$

X5.1.3 *Case 2*: Only O₂ and CO₂ are measured—Calculate the mass flow rate according to the Eqs in X5.1.1 (X5.1 – X5.2), and the oxygen depletion factor according to Eq X5.6:

$$\varphi = \frac{X_{O_2}^A \times [1 - X_{CO_2}^A] - X_{O_2}^A \times [1 - X_{CO_2}^A]}{X_{O_2}^A \times [1 - X_{O_2}^A - X_{CO_2}^A]} \quad (\text{X5.6})$$

and the rate of heat release according to the same equation as in X5.1.2 (Eq X5.4).

X5.1.4 *Case 3*: O₂, CO₂, and CO are measured—Calculate the mass flow rate according to the equations in X5.1.1 (Eq X5.1 and Eq X5.2), and the oxygen depletion factor according to Eq X5.7:

$$\varphi = \frac{X_{O_2}^A \times [1 - X_{CO_2}^A - X_{CO}^A] - X_{O_2}^A \times [1 - X_{CO_2}^A]}{X_{O_2}^A \times [1 - X_{O_2}^A - X_{CO_2}^A - X_{CO}^A]} \quad (\text{X5.7})$$

Then calculate the rate of heat release according to Eq X5.8:

$$\dot{q} = \left[E \times \varphi - [E_{CO} - E] \times \frac{1 - \varphi}{2} \times \frac{X_{CO}^A}{X_{O_2}^A} \right] \times \frac{M_{O_2}}{M_a} \times \frac{\dot{m}_e}{1 + \varphi \times (\alpha - 1)} \times X_{O_2}^A \quad (\text{X5.8})$$

X5.2 *Gas Yield Measurement Calculations*—Calculate the gas yields (*f*) using the following equation (Eq X5.9):

$$f_x = \frac{\int \text{mass flow rate of gas}_x \, dt}{\text{mass loss of specimen}} \quad (\text{X5.9})$$

X5.2.1 Calculate the numerator in this equation by summing the product of the fraction of combustion gas by the total mass flow rate, measured at each scan, multiplying it by the total time period involved, and dividing by the number of scans, as shown in Eq X5.10:

$$f_x = \frac{(\sum_i ([x]_i \times \dot{m}_{e(i)} \times \Delta t_i)) \times 0.001 \times \frac{M_x}{M_a}}{\text{mass loss of specimens}} \quad (\text{X5.10})$$

X5.2.2 In this equation, *[x]*, the concentration of gas, *x*, is expressed in ppm, *m_e*, the mass flow rate, calculated by Eq A4.3 or Eq A4.4, is expressed in kg/s, *M_x* is the molecular weight of gas species *x*, *Δt* is the scan period and mass loss of specimen is the mass lost over the period over which the gas yield is calculated, and is expressed in g, with 0.001 a conversion factor, to account for the unit changes.

X5.2.3 Report gas concentrations on a dry gas basis, unless water concentrations are being measured.

X5.3 *Symbols*:

<i>A</i>	= cross sectional area of duct, m ² ,
<i>C</i>	= orifice plate coefficient, kg ^{1/2} m ^{1/2} K ^{1/2} ,
<i>E</i>	= net heat released for complete combustion, per unit of oxygen consumed, 13 100 kJ/kg O ₂ ,
<i>f(Re)</i>	= Reynolds number correction,
<i>k_c</i>	= velocity profile shape factor (nondimensional),
<i>M_a</i>	= molecular weight of incoming air (29 kg/kmol),
<i>M_{dry}</i>	= molecular weight of dry air (29 kg/kmol),
<i>m_e</i>	= mass flow in exhaust duct, kg/s,
<i>m_e</i>	= <i>C</i> (<i>Δp</i> / <i>T_e</i>) ^{1/2} (mass flow, by pressure drop measurement),
<i>m_e</i>	= 26.54 × <i>A</i> × <i>k_c</i> / <i>f(Re)</i> × (<i>α</i> / <i>T_e</i>) ^{1/2} (mass flow, by velocity measurement),
<i>M_{O₂}</i>	= molecular weight of oxygen, 32 kg/kmol,
<i>M_x</i>	= molecular weight of gas species, <i>x</i> , kg/kmol,
<i>q̇</i>	= rate of heat release, kW,
<i>T_e</i>	= gas temperature at the orifice plate, K,
<i>T_s</i>	= duct temperature (near photodetector), K,
<i>V_e</i>	= volumetric flow rate in exhaust duct (at measuring location of mass flow rate), m ³ /s,
<i>V_s</i>	= volumetric flow rate at location of smoke meter (value adjusted for smoke measurement calculations), m ³ /s,
<i>X^A_{O₂}</i>	= measured mole fraction of O ₂ in incoming air, non-dimensional,
<i>X^A_{O₂}</i>	= measured mole fraction of O ₂ in exhaust flow, non dimensional,
<i>α</i>	= combustion expansion factor (nondimensional; normally a value of 1.105, except for pure propane, where the value is 1.084, to be used for calibration),
<i>Δp</i>	= pressure drop across the orifice plate or bidirectional probe, Pa,
<i>ρ</i>	= density of air at the temperature in exhaust duct, kg/m ³ , and
<i>ρ_o</i>	= density of air at 273.15 K: 1.293 (kg/m ³).

X6. METHOD OF DETERMINING SUITABILITY OF OXYGEN ANALYZERS FOR MAKING HEAT RELEASE MEASUREMENTS

X6.1 General

X6.1.1 The type of oxygen analyzer best suited for fire gas analysis is of the paramagnetic type. Electrochemical analyzers or analyzers using zirconia sensors have generally been found not to have adequate sensitivity or suitability for this type of work. The normal range of the instrument to be used is 0 to 25 vol % oxygen. The linearity of paramagnetic analyzers is, normally, better than can be checked by a user laboratory; thus verifying their linearity is not necessary. It is important, however, to confirm the noise and short-term drift of the instrument used.

X6.2 Procedure

X6.2.1 Connect two different gas bottles having approximately two percentage points apart (for example 15 vol % and 17 vol %) to a selector valve at the inlet of the analyzer.

X6.2.2 Connect the electrical power and let the analyzer warm up for 24 h, with one of the test gases from X6.2.1 flowing through it.

X6.2.3 Connect a data acquisition system to the output of the analyzer. Quickly switch from the first gas bottle to the second bottle, and immediately start collecting data, taking one data point per second. Collect data for 20 min.

X6.2.4 Determine the drift by using a least-squares analysis fitting procedure to pass a straight line through the last 19 min

of data. Extrapolate the line back through the first minute of data. The difference between the readings at 0 min and at 20 min on the fitted straight line represents the short-term drift. Record the drift in units of parts per million of oxygen.

X6.2.5 The noise is represented by the root-mean-square deviation around the fitted straight line. Calculate that root-mean-square value and record it in units of parts per million of oxygen.

X6.2.6 The analyzer is suitable for use in heat release measurements if the sum of the drift plus the noise terms is ≤ 50 ppm oxygen (note that both terms must be expressed as positive numbers).

X6.3 Additional Precautions

X6.3.1 A paramagnetic oxygen analyzer is directly sensitive to barometric pressure changes at its outlet port and to flow rate fluctuations in the sample supply stream. It is essential that the flow rate be regulated. Use either a flow rate regulator of the mechanical diaphragm type, or an electronic mass flow rate controller. In order to protect against errors due to changes in barometric pressure, one of the following procedures should be used: (a) control the back pressure to the analyzer with a back pressure regulator of the absolute-pressure type, or (b) electrically measure the actual pressure at the detector element and provide a signal correction for the analyzer output.

X7. RECOMMENDATIONS ON CABLE CONSTRUCTIONS

X7.1 In terms of the char length, IEEE 1202 has a recommendation for minimizing the number of tests of a cable construction line. Unless otherwise specified, IEEE 1202 recommends testing the minimum size construction and the cable construction with the highest weight ratio of non-metallic material to metallic material in each product line, in product lines employing identical materials.

X7.2 The objective of this recommendation is to find the construction likely to have the greatest difficulty in passing the char length test. There is no information available at present to suggest which construction would result in the severest smoke obscuration test.

X7.3 If a single construction is chosen, to maximize the probability of obtaining the severest test for char length, select the minimum size construction as follows:

X7.3.1 *Multiconductor Cables*—The smallest conductor size in the product line with the fewest conductors.

X7.3.2 *Single Insulated Conductors*—1/0 AWG or such smaller single conductor size authorized for use in cable tray by National Electrical Code ANSI/NFPA 70, latest edition. The testing of a larger size is permitted, provided that it is the smallest size in the product line.

REFERENCES

- (1) Coaker, A. W., Hirschler, M. M., Shakir, S., and Shoemaker, C. L., “Flammability Testing of New Vinyl Compounds with Low Flammability and Low Smoke Release in Cables,” *Proceedings of the 39th International Wire and Cable Symposium*, US Army CECOM, Fort Monmouth, NJ, 1990, pp. 643–654.
- (2) Coaker, A. W., Hirschler, M. M., and Shoemaker, C. L., “Rate of Heat Release Testing for Vinyl Wire and Cable Materials with Reduced Flammability and Smoke. Full Scale Cable Tray Tests and Small Scale Tests,” *Fire Safety Journal*, Vol 19, 1992, pp. 19–53.
- (3) Hirschler, M. M., “Survey of Fire Testing of Electrical Cables,” *Fire and Materials*, Vol. 16, 1992, pp. 107–118.
- (4) Mikkola, E., (VTT, Finland), First International Cone Calorimeter Users’ Seminar and Workshop, London, UK, Jan. 19, 1990.
- (5) ASME, “Fluid Meters—Their Theory and Applications,” Report of the ASME Committee on Fluid Meters, H. Bean, ed., Sixth Ed., 1971.
- (6) Ower, E., and Pankhurst, R., “The Measurement of Air Flow,” Pergamon Press, 5th Ed., 1977, pp. 112–147.
- (7) McCaffrey, B., and Heskestad, G., *Combustion and Flame*, Vol 26, 1976, pp. 125–127.
- (8) Babrauskas, V., Lawson, J., Walton, W., and Twilley, W., “Upholstered Furniture Heat Release Rates Measured with the Furniture Calorimeter,” *NBSIR 82-2604*, National Bureau of Standards, Gaithersburg, MD, 1983.
- (9) Thomas, P. H., “Int. Conf. Fire: Control the Heat ... Reduce the Hazard,” London, UK, QMC Fire and Materials Centre, Paper 1, Oct. 24–25, 1988.
- (10) Babrauskas, V., “Int. Conf. Fire: Control the Heat ... Reduce the Hazard,” London, UK, QMC Fire and Materials Centre, Paper 4, Oct. 24–25, 1988.
- (11) Babrauskas, V., and Peacock, R. D., “Heat Release Rate—The Single Most Important Variable in Fire Hazard,” Fire Retardant Chemicals Association 1990 Fall Technical Meeting, Pontevedra Beach, FL, Oct. 22–24, Technomic, Lancaster, PA, 1990, pp. 67–79.
- (12) Hirschler, M. M., “How to Measure Smoke Obscuration in a Manner Relevant to Fire Hazard Assessment: Use of Heat Release Calorimetry Test Equipment,” *Journal of Fire Sciences*, Vol 9, 1991, pp. 183–222.
- (13) Huggett, C., “Estimation of Rate of Heat Release by Means of Oxygen Consumption Measurements,” *Fire and Materials*, Vol 4, 1980, pp. 61–65.
- (14) Parker, W. J., “Calculations of the Heat Release Rate by Oxygen Consumption for Various Applications,” *NBSIR 82-2427-1*, National Bureau of Standards, Gaithersburg, MD, 1982.
- (15) Parker, W. J., “Calculations of the Heat Release Rate by Oxygen Consumption for Various Applications,” *Journal of Fire Sciences*, Vol 2, Sept./Oct., 1984, pp. 380–395.
- (16) Hirschler, M. M. “Fire and Polymers: Hazards Identification and Prevention,” G. L. Nelson, ed., American Chemical Society, Washington, DC, 1990, p. 462.
- (17) Debanne, S. M., Hirschler, M. M., and Nelson, G. L., “The Importance of Carbon Monoxide in the Toxicity of Fire Atmospheres,” *Fire Hazard and Fire Risk Assessment, ASTM STP 1150*, M. M. Hirschler, ed., ASTM, Philadelphia, PA, 1992, pp. 9–23.
- (18) Parker, W. J., Tu, K. M., Nurbakhsh, S., and Damant, G. H., “Furniture Flammability: an Investigation of the California Technical Bulletin 133 Test—Part III: Full Scale Chair Burns,” NISTIR 90-4375, 1990.
- (19) Ostman, B., “Comparison of Smoke Release from Building Products,” “Int. Conf: Fire, Control the Heat ... Reduce the Hazard,” London, UK, Fire Research Station, UK, Paper 8, October 24–25, 1988.
- (20) Thornton, W., “The Relation of Oxygen to the Heat of Combustion of Organic Compounds,” *Philosophical Magazine and Journal of Science*, Vol. 33, No. 196, 1917.
- (21) Huggett, C., “Estimation of Rate of Heat Release by Means of Oxygen Consumption Measurements,” *Fire and Materials*, Vol. 4, 1980, pp. 61–65.
- (22) Parker, W., “An Investigation of the Fire Environment in the ASTM E-84 Tunnel Test,” *NBS Technical Note 945*, National Bureau of Standards, Gaithersburg, MD, 1977.
- (23) Sensenig, D., “An Oxygen Consumption Technique for Determining the Contribution of Interior Wall Finishes to Room Fires,” *NBS Technical Note 1182*, National Bureau of Standards, Gaithersburg, MD, 1980.
- (24) Parker, W., “Calculations of the Heat Release Rate by Oxygen Consumption for Various Applications,” *NBSIR 812-2427-1*, National Bureau of Standards, Gaithersburg, MD, 1982.
- (25) Babrauskas, V., “Development of the Cone Calorimeter—A Bench-Scale Rate of Heat Release Apparatus Based on Oxygen Consumption,” *NBSIR 82-2611*, National Bureau of Standards, Gaithersburg, MD, 1982.
- (26) American Society for Testing and Materials, “Proposed Method for Room Fire Test of Wall and Ceiling Materials and Assemblies,” *Annual Book of ASTM Standards*, Vol. 04.07, 1983, p. 958.

SUMMARY OF CHANGES

Committee D09 has identified the location of selected changes to this standard since the last issue (D5424 – 10), that may impact the use of this test method. (Approved Nov. 1, 2014.)

(1) Revised subsections 2.2 – 2.6.

(2) Revised subsection X1.4.1.

ASTM International takes no position respecting the validity of any patent rights asserted in connection with any item mentioned in this standard. Users of this standard are expressly advised that determination of the validity of any such patent rights, and the risk of infringement of such rights, are entirely their own responsibility.

This standard is subject to revision at any time by the responsible technical committee and must be reviewed every five years and if not revised, either reapproved or withdrawn. Your comments are invited either for revision of this standard or for additional standards and should be addressed to ASTM International Headquarters. Your comments will receive careful consideration at a meeting of the responsible technical committee, which you may attend. If you feel that your comments have not received a fair hearing you should make your views known to the ASTM Committee on Standards, at the address shown below.

This standard is copyrighted by ASTM International, 100 Barr Harbor Drive, PO Box C700, West Conshohocken, PA 19428-2959, United States. Individual reprints (single or multiple copies) of this standard may be obtained by contacting ASTM at the above address or at 610-832-9585 (phone), 610-832-9555 (fax), or service@astm.org (e-mail); or through the ASTM website (www.astm.org). Permission rights to photocopy the standard may also be secured from the Copyright Clearance Center, 222 Rosewood Drive, Danvers, MA 01923, Tel: (978) 646-2600; <http://www.copyright.com/>