



Standard Test Method for Impact Resistance of Flat, Rigid Plastic Specimen by Means of a Striker Impacted by a Falling Weight (Gardner Impact)¹

This standard is issued under the fixed designation D5420; the number immediately following the designation indicates the year of original adoption or, in the case of revision, the year of last revision. A number in parentheses indicates the year of last reapproval. A superscript epsilon (ϵ) indicates an editorial change since the last revision or reapproval.

1. Scope*

1.1 This test method covers the determination of the relative ranking of materials according to the energy required to crack or break flat, rigid plastic specimens under various specified conditions of impact of a striker impacted by a falling weight.

1.2 The values stated in SI units are to be regarded as the standard. The values given in parentheses are for information only.

1.3 *This standard does not purport to address all of the safety concerns, if any, associated with its use. It is the responsibility of the user of this standard to establish appropriate safety and health practices and determine the applicability of regulatory limitations prior to use.*

NOTE 1—There is no known ISO equivalent to this standard.

2. Referenced Documents

2.1 *ASTM Standards:*²

- D618 Practice for Conditioning Plastics for Testing
- D883 Terminology Relating to Plastics
- D1600 Terminology for Abbreviated Terms Relating to Plastics
- D2794 Test Method for Resistance of Organic Coatings to the Effects of Rapid Deformation (Impact)
- D3763 Test Method for High Speed Puncture Properties of Plastics Using Load and Displacement Sensors
- D4066 Classification System for Nylon Injection and Extrusion Materials (PA)
- D4226 Test Methods for Impact Resistance of Rigid Poly-(Vinyl Chloride) (PVC) Building Products
- D5628 Test Method for Impact Resistance of Flat, Rigid Plastic Specimens by Means of a Falling Dart (Tup or Falling Mass)

¹ This test method is under the jurisdiction of ASTM Committee D20 on Plastics and is the direct responsibility of Subcommittee D20.10 on Mechanical Properties. Current edition approved May 1, 2016. Published May 2016. Originally approved in 1993. Last previous edition approved in 2010 as D5420 - 10. DOI: 10.1520/D5420-16.

² For referenced ASTM standards, visit the ASTM website, www.astm.org, or contact ASTM Customer Service at service@astm.org. For *Annual Book of ASTM Standards* volume information, refer to the standard's Document Summary page on the ASTM website.

- D5947 Test Methods for Physical Dimensions of Solid Plastics Specimens
- E171 Practice for Conditioning and Testing Flexible Barrier Packaging
- E691 Practice for Conducting an Interlaboratory Study to Determine the Precision of a Test Method

3. Terminology

3.1 *Definitions*—For definitions of plastics terms used in this test method, see Terminologies D883 and D1600.

3.2 *Definitions of Terms Specific to This Standard:*

3.2.1 *failure (of test specimen)*—the presence of any crack or split created by the impact of the falling weight that can be seen by the naked eye under normal laboratory lighting conditions.

3.2.1.1 *Discussion*—Failure shall include the following: (1) complete shattering of the plaque; (2) any crack radiating out toward the edges of the plaque on either surface of the plaque; (3) any radial crack within or just outside the impact area of the striker; (4) any hole in the plaque, whether due to brittle or ductile puncture, where unobstructed light or water could pass through; (5) any brittle splitting of the bottom surface of the plaque; and (6) any glassy-type chip dislodged from or loosened from the plaque.

3.2.1.2 *Discussion*—Since the interpretation of failure may be slightly different between material types, refer to the appropriate material specification for guidance.

3.2.1.3 *Discussion*—Cracks usually start at the surface opposite the one that is struck. For example, in some cases incipient cracking in glass-reinforced polymers is difficult to differentiate from the reinforcing fibers. In such cases, apply a penetrating dye such as gentian violet to the stressed surface to determine the onset of crack formation.

3.2.2 *mean-failure energy (mean impact resistance)*—the energy required to produce 50 % failures, equal to the product of the constant mass and mean failure height.

3.2.3 *mean-failure height (impact-failure height)*—the height at which a standard mass, when dropped on test specimens, will cause 50 % failures.

*A Summary of Changes section appears at the end of this standard

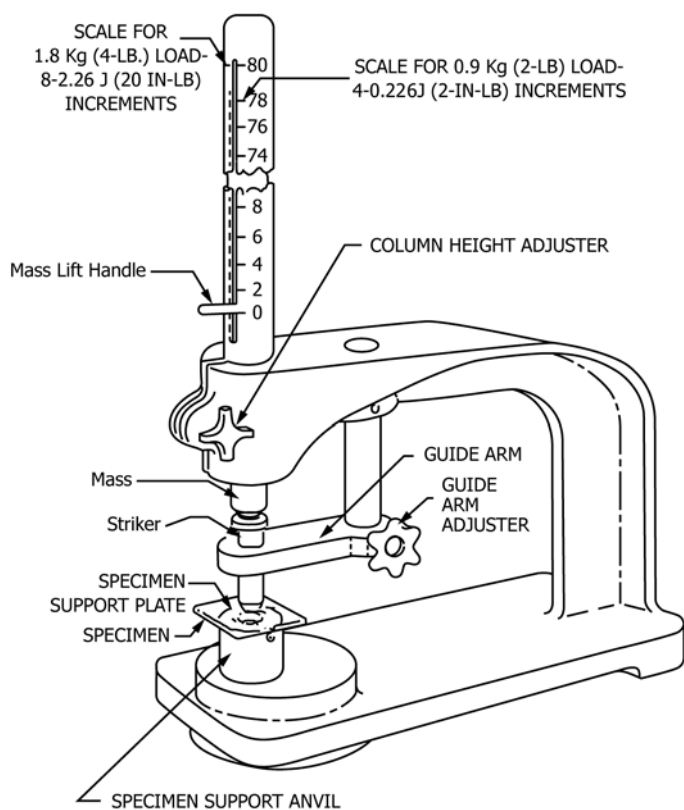

FIG. 1 Impact Tester

4. Summary of Test Method

4.1 In this test method, a weight falls through a guide tube and impacts a striker resting on top of a supported specimen. The fixed weight is dropped from various heights (see Fig. 1).

4.2 The procedure determines the energy (mass × gravity × height) that will cause 50 % of the specimens tested to fail (mean-failure energy).

4.3 The technique used to determine mean-failure energy is commonly called the Bruceton Staircase Method, or the Up-and-Down Method (1).³ Testing is concentrated near the mean, reducing the number of specimens required to obtain a reasonably precise estimate of the impact resistance.

4.4 This test method permits the use of different striker diameters and specimen support plate geometries to obtain different modes of failure, permit easier sampling, or test limited amounts of material. There is no known means for correlating the results of tests made by different methods or procedures.

5. Significance and Use

5.1 Plastics are viscoelastic and it is possible that they are sensitive to changes in velocity of weights falling on their surfaces. However, the velocity of a free-falling object is a function of the square root of the drop height. A change of a factor of two in the drop height will cause a change of only 1.4

³ The boldface numbers in parentheses refer to the list of references found at the end of this test method.

in velocity. Hagan, et al (2) found that the mean-failure energy of sheeting was constant at drop heights between 0.30 and 1.4 m. Different materials respond differently to changes in the velocity of impact.

5.2 The test conditions used in Geometry GA are the same as those used in Geometry FA of Test Method D5628 (see Table 1).

5.3 The test conditions of Geometry GB are equivalent to the geometry used for the Gardner Variable Height Impact Test (3).

5.4 The test conditions of Geometry GC cause a punch-shear type of failure because the support-plate hole is close to the diameter of the striker.

5.5 The test conditions of Geometry GD are the same as those in Test Method D3763.

5.6 The test conditions of Geometry GE are the same as those in Test Method D4226, impactor head configuration H.25.

5.7 Because of the nature of impact testing, the selection of a test method and striker must be somewhat arbitrary. Consider the end use environment and requirements when choosing from the available striker geometries. The selection of any one of the striker geometries is permitted.

NOTE 2—Material processing can have a significant affect on the development of a plastic’s physical properties. Consult relevant material standards for processing guidelines

6. Interferences

6.1 Falling-weight-impact test results are dependent on the geometry of the falling weight, striker, and the support. Thus, use impact tests only to obtain relative rankings of materials. Impact values cannot be considered absolute unless the geometry of the test equipment and specimen conform to the end-use requirement. Data obtained with different geometries, cannot, in general, be compared directly with each other.

6.1.1 Falling-weight-impact types of tests are not suitable for predicting the relative ranking of materials at impact velocities differing greatly from those imposed by these test methods.

6.2 As cracks usually start at the surface opposite the one that is struck, the results obtained can be greatly influenced by the surface characteristics of the test specimens. Therefore, factors including surface features (flaws, texturing, and so

TABLE 1 Striker and Specimen-Support-Plate Dimensions

Geometry	Striker Diameter, mm (in.)	Support Plate Inside Diameter, mm (in.)
GA	15.86 ± 0.10	76.0 ± 3.0
	(0.625 ± 0.004)	(3.00 ± 0.12)
GB	15.86 ± 0.10	31.75 ± 0.025
	(0.625 ± 0.004)	(1.25 ± 0.001)
GC	15.86 ± 0.10	16.26 ± 0.025
	(0.625 ± 0.004)	(0.640 ± 0.001)
GD	12.70 ± 0.10	76.0 ± 3.0
	(0.500 ± 0.004)	(3.00 ± 0.12)
GE	12.70 ± 0.10	16.26 ± 0.025
	(0.500 ± 0.004)	(0.640 ± 0.001)

forth), surface composition, orientation due to specimen preparation, and so forth, are important variables and will influence results.

6.3 Impact properties of plastic materials can be very sensitive to temperature. This test can be carried out at any reasonable temperature and humidity, thus representing actual-use environments. However, this test method is intended primarily for rating materials under specific impact conditions.

6.4 It is possible that the apparatus used in this test method will not have sufficient energy available to cause failure of some specimens under the conditions of this procedure.

7. Apparatus

7.1 *Testing Mechanism*—The apparatus is shown in Fig. 1. Adapt the apparatus from Test Method D2794 for use in this test method or obtain the apparatus commercially. The apparatus shall consist of the following: suitable base to withstand the impact shock; steel-rod impact mass, weighing 0.9 kg (2 lb), 1.8 kg (4 lb), or 3.6 kg (8 lb); a hardened steel striker having a round nose with diameter described in 7.2.1 and 7.2.2 and Table 1; a slotted guide tube 1.0 m (40 in.) in length, in which the impact mass slides, having graduations in newton-metres (inch-pound increments) or multiples thereof. Use a bracket to hold the tube in a vertical position by attaching it to the base and also to hold the hand knob, which is a pivot arm alignment for the striker, about 50 mm (2 in.) under the tube. Mount this instrument firmly to a rigid table or bench. Round the top edge of the opening in each specimen-support plate to a 1.0 ± 0.2 -mm (0.039 ± 0.008 -in.) radius, except in Geometry GE which has a radius of 0.75 mm (0.031 in.).

7.1.1 The tester shall be mounted so that the axis of the tube is plumb when measured with a spirit level at least 300 mm (12 in.) in length.

7.2 Striker Geometries:

7.2.1 For Geometries GA, GB, and GC, the striker shall have a rounded nose with a diameter of 15.86 ± 0.10 mm (0.625 ± 0.004 in.).

7.2.2 For Geometries GD and GE the striker shall have a rounded nose with a diameter of 12.70 ± 0.1 mm (0.500 ± 0.004 in.).

7.2.3 With Geometries GA and GD, a specimen-support plate with a hole 76.0 ± 3.0 mm (3.00 ± 0.12 in.) in diameter is mounted in the apparatus. A suggested design is given in Fig. 2.

7.2.4 With Geometry GB, the specimen-support plate has a 31.75 ± 0.025 -mm (1.25 ± 0.001 -in.) diameter hole. This geometry can be achieved by removing the removable support ring on the standard Gardner instrument.

7.2.5 With Geometries GC and GE, the standard removable specimen-support plate, with a hole 16.26 ± 0.025 mm (0.640 ± 0.001 in.) in diameter, is mounted in the specimen support anvil (see Fig. 3 for Geometry GC and Fig. 4 for Geometry GE).

7.3 *Supporting Base*—In order to minimize the energy absorption, compression, and deflection of the support, affix the tester to a dense, solid block or base weighing a minimum of 375 lb (see Appendix X2). The main body of the block or

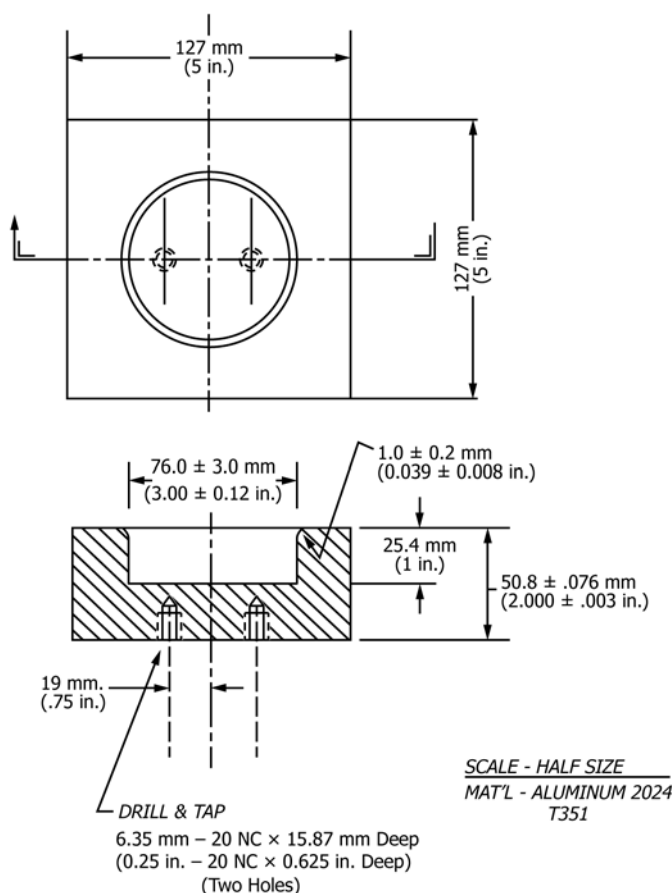

FIG. 2 Specimen-Support Plate Used for Geometries GA and GD

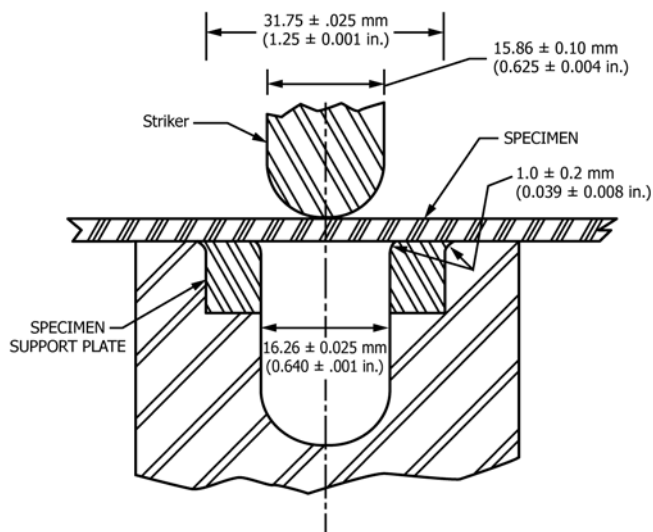
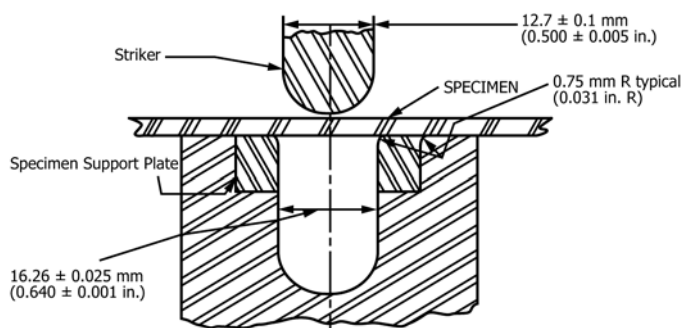

FIG. 3 Striker/Specimen/Support Plate Configuration for Geometries GB and GC (Geometry GC Shown)

base shall have maximum dimensions of 16 by 30 by 30 in. (height by width by depth). Place this block or base at a height suitable for ease of operation. It is not necessary to bolt blocks or bases of this weight to the floor. Alternatively, affix testers directly to the floor. Use of rubber mats either directly under the tester or supporting apparatus is prohibited.



NOTE 1—Depth of penetration when fully seated shall be 12.2 ± 0.1 mm (0.48 ± 0.04 in.).

FIG. 4 Striker/Specimen/Support Plate Configuration for Geometry GE

NOTE 3—Such block dimensions conform to commercially available butcher block tables.

7.3.1 Bolt supporting bases or tables lighter than 375 lb to a concrete floor. For each different material tested, make comparisons between mean failure energy data generated using this support and one where the tester is fixed directly to the concrete floor. If mean failure energy differences between two types of supports are found to be statistically nonsignificant, use of the lighter support shall be allowed.

7.3.2 If the weight of the butcher block that was originally 375 lb or greater decreases with time to less than 375 lb, increase the block weight to a minimum of 375 lb by adding a suitable amount of weight to the bottom of the table. The weight shall be tightly affixed and in direct contact with the bottom of the table and not cause any vibrations during the impact test.

NOTE 4—The weight of the butcher block can decrease over time due, for instance to drying.

7.4 *Micrometer*, for measurement of specimen thickness. Ensure that the accuracy is 1 % of the average thickness of the specimens used. See Test Methods D5947 for descriptions of suitable micrometers.

8. Sampling

8.1 Sample using a statistically acceptable procedure. The samples shall be representative of the lot under study. When taken from a commercial production process, the process shall be in a state of statistical control.

9. Test Specimens

9.1 The diameter or width of flat test specimens shall be at least 25 mm (1.00 in.) greater than the diameter of the hole in the support plate. The specimens shall be free of obvious imperfections, unless the imperfections constitute a variable under study.

9.2 The thickness of any specimen in a sample shall not differ by more than 5 % from the average specimen thickness of that sample. However, if variations greater than 5 % are unavoidable in a sample that is obtained from parts, the sample shall be permitted to be tested, but the data shall not be used for referee purposes. Machining specimens to reduce thickness variation is not permissible.

9.3 When the approximate mean-failure height for a given sample is known, 20 specimens will usually yield sufficiently precise results. If the approximate mean-failure height is unknown, six or more additional specimens shall be used to determine the appropriate starting point of the test.

9.4 Visually examine the specimens to ensure they are free of cracks or other obvious imperfections or damages, unless these imperfections constitute variables under study. For specification purposes, do not test samples known to be defective. Production parts shall be tested in the as-received condition to determine conformance to specified standards.

9.5 Select a suitable method for making the specimen that will minimize the effect of specimen preparation on the impact resistance of the material. Refer to the appropriate material specification for requirements for specimen preparation.

NOTE 5—As few as ten specimens often yield sufficiently reliable estimates of the mean-failure height. However, in such cases the estimated standard deviation will be relatively large (1).

10. Conditioning

10.1 Unless otherwise specified by contract or relevant material specification, condition the test specimens in accordance with Procedure A of Practice D618 or Specification E171, for those tests where conditioning is required. Temperature and humidity tolerances shall be in accordance with Section 7 of Practice D618, unless otherwise specified by contract or relevant ASTM material specification.

10.1.1 Note that for some hygroscopic materials, such as nylons, the material specifications (for example, Specification D4066) call for testing “dry as-molded specimens.” Such requirements take precedence over the above routine preconditioning to 50 % relative humidity and require sealing the specimens in water vapor-impermeable containers as soon as molded and not removing them until ready for testing.

10.2 Conduct tests at the same temperature and humidity used for conditioning with tolerances in accordance with Section 7 of Practice D618, unless otherwise specified by contract or relevant ASTM material specification.

11. Procedure

11.1 Determine the number of specimens for each sample to be tested, as specified in 9.3.

11.2 Mark the specimens and condition as specified in 10.1.

11.3 Prepare the test apparatus for the geometry (GA, GB, GC, GD, or GE) selected.

11.4 Measure and record the thickness of each specimen in the area of impact. In the case of injection molded specimens, it is sufficient to measure and record thickness for one specimen when it has been previously demonstrated that the thickness does not vary by more than 5 %.

11.5 Choose a specimen at random from the sample. Use a random numbers table if desired.

11.6 Position the specimen. Ensure that the same surface or area, or both, is targeted on all test specimens. (see 6.2).

NOTE 6—Normally the specimen is not clamped because the test

apparatus does not have provision for clamping. However, the apparatus can be modified to permit clamping, which should improve the precision of the measurement.

11.7 Place the test specimen on the tester anvil, after raising the weight and striker foot. Be sure the specimen is flat against the specimen-support plate before the striker foot is brought in contact with the top surface of the specimen. (Fig. 3 shows the position of the test specimen.) Raise the weight in the tube to the desired impact value, as shown on the appropriate scale, and release it so that the weight drops on the striker.

11.8 As a result of the wide range of failure types that are observed with different materials, the definition of failure defined in the material specification shall take precedence over the definition stated in 3.2.1. Other definitions of failure shall be used if agreed upon between the supplier and the user.

11.9 Remove the specimen and examine it to determine whether or not it has failed. Permanent deformation alone is not considered failure, but note the extent of such deformation (depth, area). For some polymers, for example, glass-reinforced polyester, it is difficult to assess incipient cracking with the naked eye. In such cases, it is permissible to expose the stressed surface to a penetrating dye, such as gentian violet, to help determine the onset of cracking.

11.10 If the first specimen fails, decrease the drop height while keeping the mass constant (see 11.11). If the first specimen does not fail, increase the drop height one increment, as above. Then test the second specimen.

11.11 In this manner, select the impact height for each test from the results observed with the specimen just previously tested. Test each specimen only once.

11.12 At the start of a test, a continuous run of seven or more identical results (failure or nonfailure) is indicative of an improper starting heights and affects final results. Re-estimate approximate starting height and restart the test.

11.13 Keep a running plot of the data, as shown in Appendix X1. Use one symbol, such as *X*, to indicate a failure and a different symbol, such as *O*, to indicate a nonfailure at each height level.

12. Calculation

12.1 *Mean-Failure Height*—If a constant-mass procedure was used, calculate the mean-failure height from the test data obtained, as follows:

$$h = h_o + d_h(A/N \pm 0.5) \tag{1}$$

TABLE 2 Precision, Method GA

Material	Mean, J	Values Expressed as Percent of the Mean	
		<i>V_r</i>	<i>r</i>
33 % Glass-Reinforced Nylon (PA)	0.75	4.66	13.2
Acetal (POM)	2.12	6.90	19.5
Impact Polystyrene	15.1	2.20	6.23

V_r = within-laboratory coefficient of variation of the mean
r = 2.83 *V_r*

where:

- h* = mean-failure height, mm (or in.),
- d_h* = increment of height, mm (or in.),
- N* = total number of failures or nonfailures, whichever is smaller. For ease of notation, call whichever are used events,
- h_o* = lowest height at which an event occurred, mm (or in.),
- i* = 0, 1, 2 ... *k* (counting index, starts at *h_o* or *w_o*),
- n_i* = number of events that occurred at *h_i* or *w_i*,
- h_i* = *h_o* + *i**d_h*, and

$$A = \sum_{i=0}^k in_i,$$

In calculating *h*, the negative sign is used when the events are failures. The positive sign is used when the events are nonfailures. Refer to the example in Appendix X1.

12.2 *Mean-Failure Energy*—Compute the mean failure energy as follows:

$$MFE = hwf \tag{2}$$

where:

- MFE* = mean-failure energy, J (or in.·lbf),
- h* = mean-failure height as applicable, mm (or in.),
- w* = constant mass, kg (or lb), and
- f* = factor for conversion to joules.
- Use *f* = 9.80665 × 10⁻³ if *h* = mm and *w* = kg; Use 0.11299 if *h* = in. and *w* = lb; Use *f* = 1.0 for inch-pound units (in.·lbf, in., lb).

12.3 *Estimated Standard Deviation of the Sample*—If desired for record purposes, calculate the estimated standard deviation of the sample for variable height as follows:

$$s_h = 1.62d_h [B/N - (A/N)^2] + 0.047d_h \tag{3}$$

where:

- s_h* = estimated standard deviation, height, mm (or in.), and

$$B = \sum_{i=0}^k i^2 n_i.$$

The above calculation is valid for [B/N - (A/N)²] > 0.3. If the value is <0.3, use Table 1 from Ref (3).

12.4 *Estimated Standard Deviation of the Sample Mean*—Calculate the estimated standard deviation of the sample mean-failure height as follows:

$$s_{\bar{h}} = Gs_h/\sqrt{N} \tag{4}$$

where:

- s_h* = estimated standard deviation of the mean height, mm (or in.), and
- G* = factor that is a function of *s/d* (see Table X1.2).

A sample computation of *s_w* is found in Appendix X1.

NOTE 7—For values of *G* at other levels of *s/d*, see Fig. 22 in Ref (4).

12.5 *Estimated Standard Deviation of the Mean-Failure Energy*—Calculate the estimated standard deviation of the mean-failure energy as follows:

TABLE 3 Precision, Method GB

Material	Mean, J	Values Expressed as Percent of the Mean	
		V_r	r
33 % Glass-Reinforced Nylon (PA)	0.99	3.18	8.99
Acetal (POM)	2.57	11.6	32.8
Impact Polystyrene	10.3	12.3	34.7
Acrylonitrile-Butadiene-Styrene (ABS)	26.9	6.56	18.6

V_r = within-laboratory coefficient of variation of the mean
 $r = 2.83 V_r$

TABLE 4 Precision, Method GC

Material	Mean, J	Values Expressed as Percent of the Mean	
		V_r	r
33 % Glass-Reinforced Nylon (PA)	1.82	1.92	5.44
Acetal (POM)	4.56	7.02	19.9
Impact Polystyrene	14.8	18.6	52.7

V_r = within-laboratory coefficient of variation of the mean
 $r = 2.83 V_r$

$$S_{MFE} = s_{\bar{h}} w f \quad (5)$$

where:

S_{MFE} = estimated standard deviation of the mean-failure energy.

13. Report

13.1 Report the following information:

13.1.1 Complete identification of the sample tested, including type of material, source, manufacturer's code, form, principal dimensions, and previous history.

13.1.2 Method of preparation of specimens.

13.1.3 Means of clamping, if any.

13.1.4 Statement of geometry (GA, GB, GC, GD, GE).

13.1.5 Thickness of specimens tested (average and range).

13.1.6 Number of test specimens employed to determine the mean-failure height.

13.1.7 Mean-failure energy.

13.1.8 Types of failure, for example: (a) crack or cracks on one surface only (the plaque could still hold water), (b) cracks that penetrate the entire thickness (water would probably penetrate through the plaque), (c) brittle shatter (the plaque is in several pieces after impact), or (d) ductile failure (the plaque is penetrated by a blunt tear). Report other observed deformation due to impact, whether the specimens fail or not.

13.1.9 Date of test and operator name.

13.1.10 Test temperature.

13.1.11 In no case shall results obtained with arbitrary geometries differing from those contained in these test methods be reported as values obtained by Test Method D5420.

14. Precision and Bias⁴

14.1 Table 2, Table 3, and Table 4 are based on a round robin conducted in 1977 involving four materials tested by four

⁴ Supporting data have been filed at ASTM International Headquarters and may be obtained by requesting Research Report RR:D20-1060.

laboratories. Data from only three laboratories were used in calculating the values in these tables. For each material, all samples were prepared at one source, but the individual specimens were prepared at the laboratories that tested them. Each test result was the mean of multiple individual determinations (Bruceton Staircase Procedure) (1). Each laboratory obtained two test results for a material. **Warning**—The following explanations of r and R (14.2 – 14.2.3) are only intended to present a meaningful way of considering the approximate precision of this test method. Do not apply the data in Table 2 and Table 4 rigorously for acceptance or rejection of a material. Data in these tables are specific to the round robin study and are not always representative of other lots, conditions, materials, or laboratories. The principles of 14.2 – 14.2.3 are valid if users of this test method apply the principles outlined in Practice E691 to generate data specific to their laboratory and materials, or between specific laboratories.

14.1.1 *Glass-Reinforced Nylon (33 % Glass)*—101 by 101 by 3.2 mm (4 by 4 by 1/8 in.) cut from injection-molded plaques.

14.1.2 *Acetal (Homopolymer)*—101 by 101 by 3.2 mm (4 by 4 by 1/8 in.) cut from injection-molded plaques.

14.1.3 *Impact Polystyrene*—101 by 101 by 3.2 mm (4 by 4 by 1/8 in.) cut from extruded sheet.

14.1.4 *ABS*—101-mm diameter by 3.2-mm (4-in. diameter by 1/8-in.) injection-molded disks.

14.2 *Concept of r and R* —If V_r and V_R have been calculated from a large enough body of data, and for test results that were means from testing multiple individual specimens, then the following concepts apply:

14.2.1 *Repeatability, r* —In comparing two test results for the same material, obtained by the same operator using the same equipment on the same day, judge the two results as not equivalent if they differ by more than the r value for that material.

14.2.2 *Reproducibility, R* —In comparing two test results for the same material, obtained by different operators using different equipment in different laboratories, reproducibility statistics were not calculated because data from only four and three laboratories do not justify making these calculations.

14.2.3 Any judgement in accordance with 14.2.1 would have an approximate 95 % (0.95) probability of being correct.

14.3 *Bias*—There are no recognized standards by which to estimate bias of this test method.

14.4 Efforts to form a task group to address between-laboratory reproducibility of this test method have been unsuccessful. Persons interested in participating in such a task group need to contact ASTM Headquarters.

15. Keywords

15.1 dart impact; falling weight impact; Gardner impact; impact; impact resistance; mean-failure energy; mean-failure height; rigid plastic

APPENDIXES

(Nonmandatory Information)

X1. SAMPLE CALCULATIONS

X1.1 See **Table X1.1** and **Table X1.2** for sample calculations and values of *G* for obtaining the estimated standard deviation.

TABLE X1.1 Sample Calculations

Total Dart Height, mm	Outcome of Test (X = failure; O = nonfailure)																				<i>n_x</i>	<i>n_o</i>	<i>i</i>	<i>n_i</i>	<i>in_i</i>	<i>i²n_i</i>
	1	2	3	4	5	6	7	8	9	10	11	12	13	14	15	16	17	18	19	20						
500						X															1	0	2	1	2	4
475					O		X		X				X		X						4	1	1	4	4	4
450		X		O				O		X		O		O		X		X		O	4	5	0	4	0	0
425	O		O								O						O		O		0	5				
Totals																				9 (<i>N_x</i>)	11 (<i>N_o</i>)		9 (<i>N</i>)	6 (<i>A</i>)	8 (<i>B</i>)	

NOTE 1—

where:

$$h_o = 450; N = N_x = 9; d = 25$$

$$h = h_o + d_h (A/N - 0.5)$$

$$= 450 + 25 (6/9 - 0.5)$$

$$= 454.2 \text{ mm}$$

$$s_h = 1.62d_h [B/N - (A/N)^2] + 0.047d_h$$

$$= 1.62 (25) [8/9 - (6/9)^2] + 0.047 (25)$$

$$= 19.2 \text{ mm}$$

$$s/d = 19.2/25 = 0.77; G = 1.035 \text{ (from Table X1.2)}$$

$$s_{\bar{h}} = Gs_h/\sqrt{N} = 1.035 (0.77)/\sqrt{9} = 0.27 \text{ mm}$$

TABLE X1.2 Values of *G* for Obtaining the Estimated Standard Deviation of the Mean

<i>s/d</i>	0.00	0.01	0.02	0.03	0.04	0.05	0.06	0.07	0.08	0.09
0.40	1.18	1.175	1.17	1.16	1.155
0.50	1.15	1.145	1.14	1.135	1.13	1.125	1.12	1.11	1.105	1.10
0.60	1.095	1.09	1.085	1.08	1.075	1.07	1.07	1.065	1.06	1.06
0.70	1.055	1.055	1.05	1.05	1.045	1.04	1.04	1.035	1.035	1.03
0.80	1.03	1.025	1.025	1.02	1.02	1.02	1.015	1.015	1.015	1.01
0.90	1.01	1.01	1.005	1.005	1.005	1.00	1.00	1.00	0.995	0.995
1.00	0.995	0.99	0.99	0.99	0.985	0.985	0.985	0.985	0.98	0.98
1.10	0.98	0.98	0.98	0.975	0.975	0.975	0.975	0.975	0.975	0.97
1.20	0.97	0.97	0.97	0.97	0.97	0.97	0.965	0.965	0.965	0.965
1.30	0.965	0.965	0.965	0.965	0.96	0.96	0.96	0.96	0.96	0.96
1.40	0.96	0.96	0.96	0.955	0.955	0.955	0.955	0.955	0.955	0.955
1.50	0.955	0.955	0.955	0.95	0.95	0.95	0.95	0.95	0.95	0.95
1.60	0.95	0.95	0.95	0.95	0.945	0.945	0.945	0.945	0.945	0.945
1.70	0.945	0.945	0.945	0.945	0.945	0.945	0.94	0.94	0.94	0.94
1.80	0.94	0.94	0.94	0.94	0.94	0.94	0.94	0.94	0.94	0.935
1.90	0.935	0.935	0.935	0.935	0.935	0.935	0.935	0.935	0.935	0.935
2.00	0.935	0.935	0.935	0.93	0.93	0.93	0.93	0.93	0.93	0.93

X2. TESTING SUMMARY

TABLE X2.1 Testing Summary, MFE versus Table Weight, 8 lb Weight^A

Plastic	MFE Averages			
	57 lb Base	215 lb Base	440 lb Base	Floor
ABS	273	256	239	240
HDPE	190	185	184	...
HIPS	179	164	162	133
PP (0.077 in.)	121	120	110	...
PP (0.0121 in.)	196	185	184	184
PVC	112	102	101	101

^A Test results are based on averages for three sets of operators, using two different testers fixed to each base. Twenty specimens were used for each sample calculation, with a minimum of 120 specimens used for each averaged test result.

X2.1 See **Table X2.1** for testing summary of mean failure energy versus table weight using an 8 lb weight.

REFERENCES

- (1) Brownlee, K. A., Hodgest, J. L., Jr., and Rosenblatt, M., "The Up-and-Down Method with Small Samples," *American Statistical Association Journal*, Vol 48, 1953, pp. 262–277.
- (2) Hagan, R. S., Schmitz, J. V., and Davis, D. A., "Impact Testing of High Impact Thermoplastic Sheet," *Technical Papers, 17th Annual Technical Conference of SPE, SPPPB*, Vol VII, January 1961.
- (3) "Test Method B—Gardner Impact, Proposed Method of Test for Impact Resistance of Fabricated Plastics Parts," *Proposed Test Methods for Plastics Parts Used in Appliances*, Society of the Plastics Industry, New York, NY, January 1965.
- (4) Natrella, M. G., "Experimental Statistics," *National Bureau of Standards Handbook 91*, October 1966, pp. 10–22 and 10–23.
- (5) Weaver, O. R., "Using Attributes to Measure a Continuous Variable in Impact Testing Plastic Bottles," *Materials Research and Standards*, Vol 6, No. 6, June 1966, pp. 285–291.

SUMMARY OF CHANGES

Committee D20 has identified the location of selected changes to this standard since the last issue (D5420 - 10) that may impact the use of this standard. (May 1, 2016)

- | | |
|--|--|
| (1) Added 7.1.1 on plumbness of vertical tube. | (3) Added new Note 4. |
| (2) Modified 7.2 based on commercially available butcher block tables. | (4) Revised Section 8 on Sampling |
| | (5) Added 11.12 on starting heights for testing. |

ASTM International takes no position respecting the validity of any patent rights asserted in connection with any item mentioned in this standard. Users of this standard are expressly advised that determination of the validity of any such patent rights, and the risk of infringement of such rights, are entirely their own responsibility.

This standard is subject to revision at any time by the responsible technical committee and must be reviewed every five years and if not revised, either reapproved or withdrawn. Your comments are invited either for revision of this standard or for additional standards and should be addressed to ASTM International Headquarters. Your comments will receive careful consideration at a meeting of the responsible technical committee, which you may attend. If you feel that your comments have not received a fair hearing you should make your views known to the ASTM Committee on Standards, at the address shown below.

This standard is copyrighted by ASTM International, 100 Barr Harbor Drive, PO Box C700, West Conshohocken, PA 19428-2959, United States. Individual reprints (single or multiple copies) of this standard may be obtained by contacting ASTM at the above address or at 610-832-9585 (phone), 610-832-9555 (fax), or service@astm.org (e-mail); or through the ASTM website (www.astm.org). Permission rights to photocopy the standard may also be secured from the Copyright Clearance Center, 222 Rosewood Drive, Danvers, MA 01923, Tel: (978) 646-2600; http://www.copyright.com/